

Hall-Effect Speed Sensor HA-P

www.bosch-motorsport.com



BOSCH
Invented for life



- ▶ Camshaft or wheel speed
- ▶ 24.0 mm depth
- ▶ Robust design
- ▶ Active low

This sensor is designed for incremental measurement of rotational speed (e.g. camshaft or wheel speed). Due to the rotation of a ferromagnetic target wheel in front of the HA-P, the magnetic field is modulated at the place of the Hall probe. A Hall-effect sensor element with integrated signal conditioning circuit detects this change and generates a digital output signal. The main feature and benefit of this sensor is the combination of a high quality production part and robust design with metal housing.

Application

Application	Speed
Max. frequency	≤ 10 kHz
Target wheel air gap	0.5 to 1.4 mm
Temperature range	-40 to 150°C
Output type	Active low
Output circuit	Open collector for 1 kOhm
Max. vibration	1,000 m/s ² at 10 Hz to 2 kHz

Technical Specifications

Mechanical Data

Weight w/o wire	70 g
Mounting	With screw 1 x M6
Bore diameter	18 mm
Installation depth L2	24 mm
Tightening torque	8 Nm

Electrical Data

Power supply	4.5 to 24 V
Current I _S	10 mA

Characteristic

Accuracy repeatability of the falling edge of tooth	< 1.5 % (≤6 kHz) < 2 % (≤10 kHz)
Signal output	0.4 V to < US

Environment

Target wheel diameter D	162.34 mm
Thickness t	12.5 mm

Width of teeth b1	3.8 mm
Width of gap b2	4.7 mm
Width of sync. gap b3	20.79 mm
Depth of teeth h	3.4 mm
Number of teeth	60-2

Connectors and Wires

Connector	1 928 404 227
Mating connector 3-pole Compact	D 261 205 335-01
Pin 1	Gnd
Pin 2	Sig
Pin 3	U _s

Installation Notes

The HA-P can be connected directly to most control units and data logging systems.

Please avoid abrupt temperature changes.

Dimensions

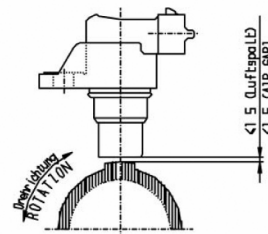
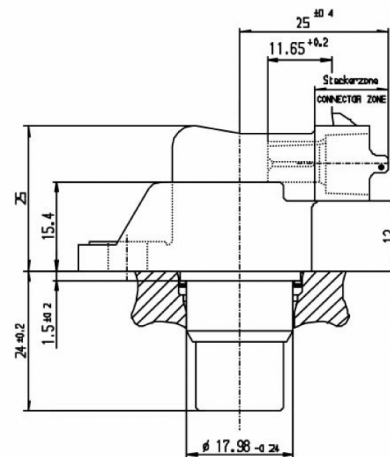
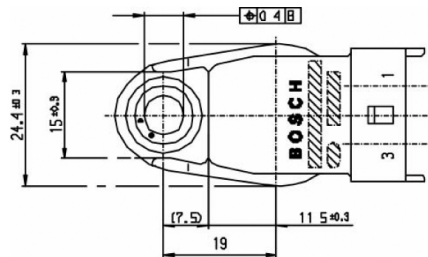

For mounting please use only the integrated plug.

If a wheel with different dimensions is used (see Environment), the technical function has to be tested individually.

Please ensure that the environmental conditions do not exceed the sensor specifications.

Please find further application hints in the offer drawing at our homepage.

Safety Note

The sensor is not intended to be used for safety related applications without appropriate measures for signal validation in the application system.

Ordering Information

Hall-Effect Speed Sensor HA-P
Order number **0 232 103 037**

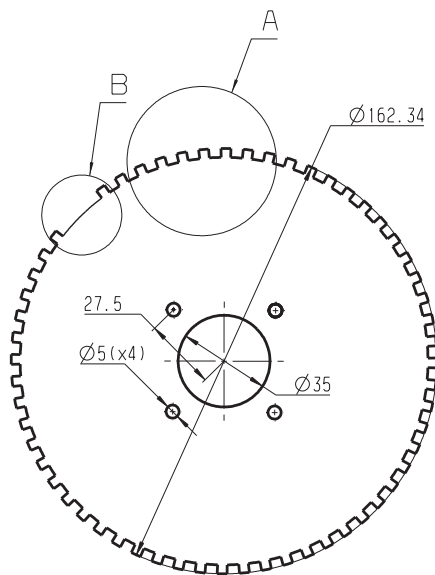

60-2 Teeth

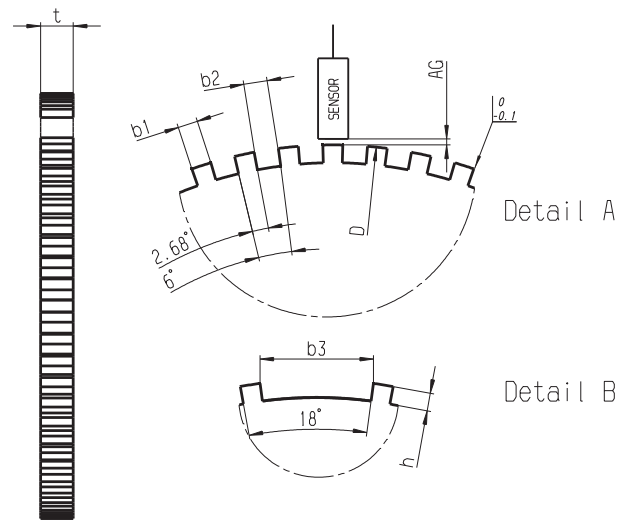

Left view

Represented by:

Europe:
 Bosch Engineering GmbH
 Motorsport
 Robert-Bosch-Allee 1
 74232 Abstatt
 Germany
 Tel.: +49 7062 911 9101
 Fax: +49 7062 911 79104
 motorsport@bosch.com
 www.bosch-motorsport.de

North America:
 Bosch Engineering North America
 Motorsport
 38000 Hills Tech Drive
 Farmington Hills, MI 48331-3417
 United States of America
 Tel.: +1 248 876 2977
 Fax: +1 248 876 7373
 motorsport@bosch.com
 www.bosch-motorsport.com

Latin America:
 Robert Bosch Ltda
 Motorsport
 Av Juscelino Kubitscheck de
 Oliveira 11800
 Zip code 81460-900
 Curitiba - Parana
 Brasilia
 Tel.: +55 41 3341 2057
 Fax: +55 41 3341 2779

Asia-Pacific:
 Bosch Engineering Japan K.K.
 Motorsport
 18F Queen's Tower C, 2-3-5 Minato Mirai
 Nishi-ku, Yokohama-shi
 Kanagawa 220-6218
 Japan
 Tel.: +81 45 650 5610
 Fax: +81 45 650 5611
 www.bosch-motorsport.jp

Australia, New Zealand and South Africa:
 Robert Bosch Pty. Ltd
 Motorsport
 1555 Centre Road
 Clayton, Victoria, 3168
 Australia
 Tel.: +61 (3) 9541 3901
 motor.sport@au.bosch.com