

# Fuel Pump FP 200

www.bosch-motorsport.com

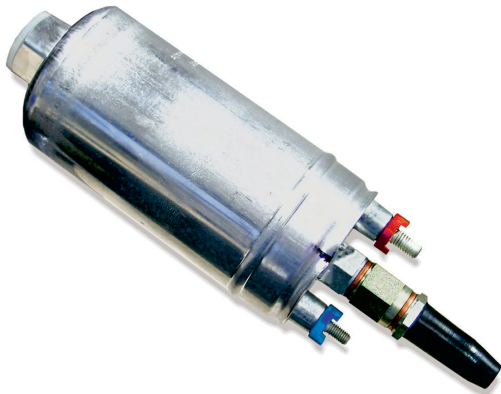

**BOSCH**  
Invented for life



- ▶ >200 l/h
- ▶ 1,030 g
- ▶ Max. 5 bar/8 bar
- ▶ Fuel lines screwed

The FP 200 is an inline roller cell pump for the installation outside or inside the fuel tank. It is capable of providing 200 l/h at 5 bar (8 bar). Bio-fuel can be delivered up to E85 (shortens lifetime!). The FP 200 is one of the most popular aftermarket fuel pumps and has an excellent price.

## Application

|                                 |  |
|---------------------------------|--|
| Fuel pressure                   | 5 bar or 8 bar   |
| Delivery rate at 5 bar and 22°C | 260 ± 5 l/h at 14 V  |
| Delivery rate at 8 bar and 22°C | 220 ± 5 l/h at 14 V  |
| Pressure limiting valve         | 10 to 12.5 bar rel.  |
| Fuel compatibility              | Up to E85 with shorter lifetime                            |
| Diesel compatibility            | Not released   |
| Operating temperature range     | -20 to 90°C  |
| Storage temperature range       | -40 to 70°C  |
| Max. vibration                  | 3 mm at 10 to 18 Hz<br>≤40 m/s <sup>2</sup> at 18 to 60 Hz |

## Technical Specifications

### Mechanical Data

|          |          |
|----------|----------|
| Diameter | 60 mm    |
| Length   | 196 mm   |
| Weight   | 1,030 g  |
| Mounting | Clamping |

### Electrical Data

|                                |             |
|--------------------------------|-------------|
| Supply voltage                 | 6 to 16.5 V |
| Operating voltage              | 13.8 V      |
| Load current at 5 bar and 22°C | ≤ 15 A      |
| Load current at 8 bar and 22°C | ≤ 18 A      |

### Characteristic

|                  |                            |
|------------------|----------------------------|
| Surface coating  | None                       |
| Color            | Silver                     |
| Non-return valve | External                   |
| Fuel filtering   | External, on pressure side |

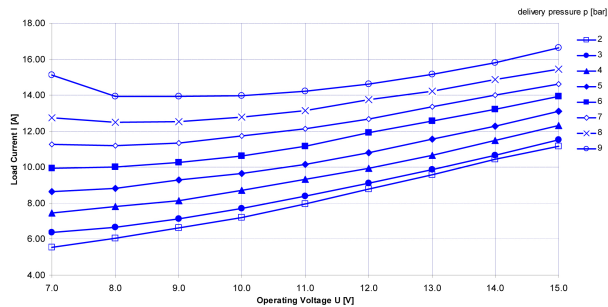
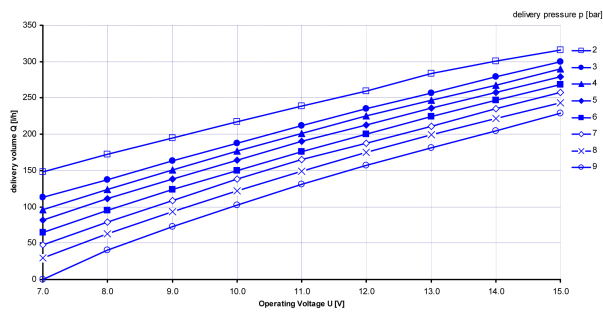
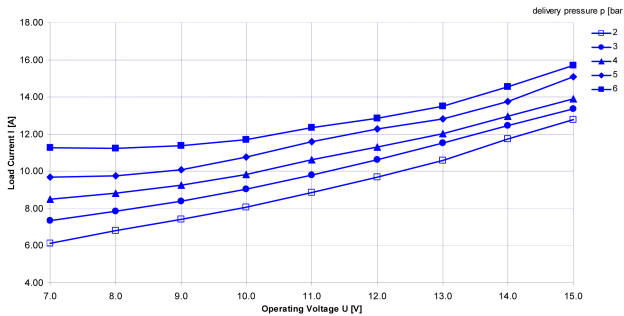
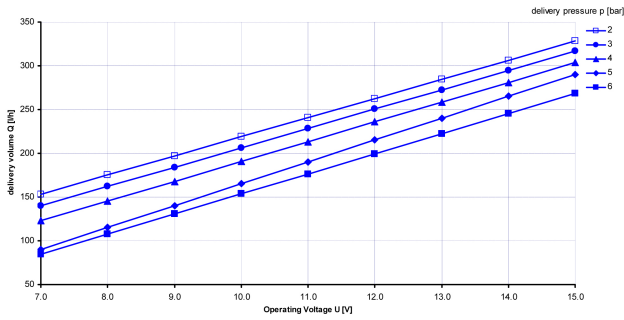

### Connectors and Wires

|                                    |                          |
|------------------------------------|--------------------------|
| Electrical connector               | +M6/-M5                  |
| Electrical mating connector        | With ring wire M6 and M5 |
| Mechanical connector intake side   | M18x1.5                  |
| Mechanical connector pressure side | M12x1.5                  |

### Installation Notes

With E26/E85 fuel run-time max. 500 h.

For technical reasons the values may vary.

Please use within the specified limit values only.

Please find further application hints in the offer drawing at our homepage.

### Ordering Information

#### Fuel Pump FP 200

Max. Pressure 5 bar

Order number **0 580 254 044**

#### Fuel Pump FP 200

Max. Pressure 8 bar

Order number **B 261 205 413-01**

Dimensions

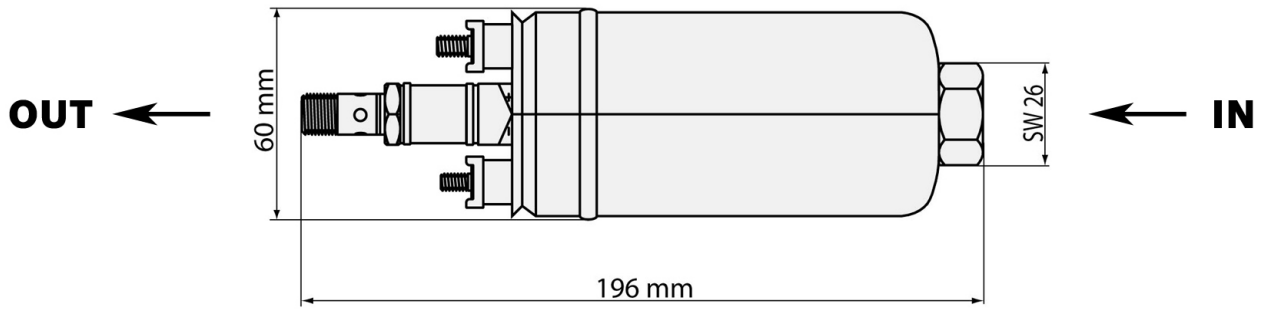

Represented by:

**Europe:**  
 Bosch Engineering GmbH  
 Motorsport  
 Robert-Bosch-Allee 1  
 74232 Abstatt  
 Germany  
 Tel.: +49 7062 911 9101  
 Fax: +49 7062 911 79104  
 motorsport@bosch.com  
 www.bosch-motorsport.de

**North America:**  
 Bosch Engineering North America  
 Motorsport  
 38000 Hills Tech Drive  
 Farmington Hills, MI 48331-3417  
 United States of America  
 Tel.: +1 248 876 2977  
 Fax: +1 248 876 7373  
 motorsport@bosch.com  
 www.bosch-motorsport.com

**Latin America:**  
 Robert Bosch Ltda  
 Motorsport  
 Av Juscelino Kubitscheck de  
 Oliveira 11800  
 Zip code 81460-900  
 Curitiba - Parana  
 Brasilia  
 Tel.: +55 41 3341 2057  
 Fax: +55 41 3341 2779

**Asia-Pacific:**  
 Bosch Engineering Japan K.K.  
 Motorsport  
 18F Queen's Tower C, 2-3-5 Minato Mirai  
 Nishi-ku, Yokohama-shi  
 Kanagawa 220-6218  
 Japan  
 Tel.: +81 45 650 5610  
 Fax: +81 45 650 5611  
 www.bosch-motorsport.jp

**Australia, New Zealand and South Africa:**  
 Robert Bosch Pty. Ltd  
 Motorsport  
 1555 Centre Road  
 Clayton, Victoria, 3168  
 Australia  
 Tel.: +61 (3) 9541 3901  
 motor.sport@au.bosch.com