

FELLOW®

STAGG EKG PRO

Electric Pour-Over Kettle

SAFETY AND MAINTENANCE

Diagram A:
Product Diagram

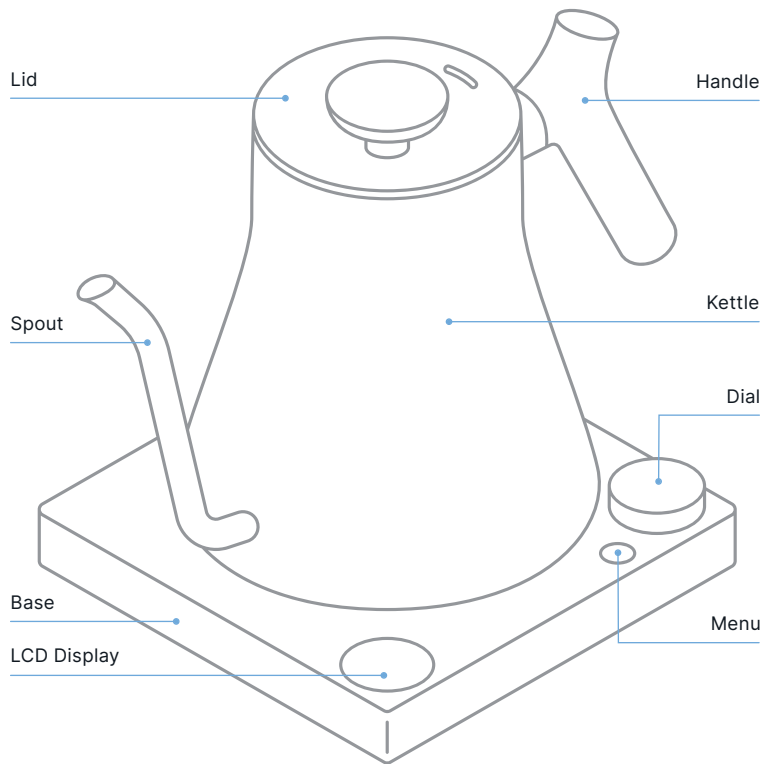

STAGG EKG PRO & PRO STUDIO EDITION

Fellow Industries Inc.
Fellowproducts.com
Email: hello@fellowproducts.com
San Francisco, CA 94110

Product Name: Stagg EKG Pro Electric Pour-Over Kettle
US Patents Pending | 2-Year Limited Warranty
Designed in San Francisco, Made in China

MODEL	SPECIFICATIONS
EP20AAAU EP20AAUK	220-240V~ / 6A / 50-60Hz / 1200-1428W Weight: 1250 g (includes kettle base) Dimensions (LxWxH): 282 mm x 172 mm x 196 mm Capacity: 0.9 L

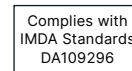

Do not discard as unsorted waste. To be sent to separate collection facilities for recovery and recycling.

FOR HOUSEHOLD USE ONLY

More info at [Fellowproducts.com/pages/stagg-ekg-GTKYG](https://fellowproducts.com/pages/stagg-ekg-GTKYG)

READ AND FOLLOW ALL INSTRUCTIONS. KEEP THIS SAFETY AND MAINTENANCE MANUAL FOR FUTURE REFERENCE.

WARNING!

Shock Hazard: This appliance has a grounded, three-pronged plug. To ensure protection against risk of electric shock or fire, connect to properly grounded outlets only. The plug fits only one way into an outlet. Do not defeat the safety purpose of the plug by modifying the plug in any way or using an adapter. Do not plug this appliance into an outlet with a voltage other than specified on the bottom of this appliance.

Do not use an adapter with this appliance.

A short power supply cord is provided to reduce the risk of becoming entangled in or tripping over a longer cord. To avoid an electrical circuit overload, do not use any high wattage appliance on the same circuit with this appliance.

IMPORTANT SAFEGUARDS

Before use, please read these safety warnings carefully and use the product (Diagram A) properly. These safety warnings are indicated for the safe and proper use of this product to prevent danger to the user or others and damage to property.

When using electrical appliances, basic safety precautions should always be followed, including the following:

- Stagg EKG Pro's electric base is small and the kettle's body looks strikingly similar to our stovetop kettle but make no mistake, they are not the same! This is an electric kettle that CANNOT be used on a stove.
- Do not place on or near a hot gas burner or electric burner, in a heated oven, or in a microwave.
- Do not touch the hot surfaces of the product. Use the handle at all times.
- To protect against fire, electric shock, and injury to persons, do not immerse cord, plug, or any other part of the kettle or base in water or other liquid.
- No part of Stagg EKG Pro is dishwasher safe. Do not put Stagg EKG Pro or any parts of Stagg EKG Pro in the dishwasher.
- Never leave Stagg EKG Pro unattended while in use or in Hold mode.
- Close supervision is necessary when any appliance is used by or near children. Do not use it within a child's reach.

- This appliance is not intended for use by persons (including children) with reduced physical, sensory, or mental capabilities, or lack of experience and knowledge.
- Children should be supervised to ensure that they do not play with the appliance.
- Unplug from outlet when not in use for extended periods of time and before cleaning.
- Allow to cool before putting on or taking off parts and before cleaning the appliance.
- To disconnect from power source, press the dial to switch "OFF" and then remove plug from outlet. Do not pull on the cord itself as it may damage the cord and eventually cause electric shock.
- Do not operate Stagg EKG Pro with a damaged cord or plug, if the kettle malfunctions, or if the product has been damaged in any manner. Return appliance to the nearest authorized service facility for examination, repair, or adjustment.
- Ensure that your main supply voltage is the same as that marked on the underside of your kettle.
- To avoid an electrical overload, do not operate another high-wattage appliance on the same circuit.
- The use of accessory attachments not recommended by Fellow may result in fire, electric shock, or injury to persons.
- Do not use outdoors.
- Do not place any utensils into the kettle.
- After unpacking kettle, dispose of all plastic bags to ensure children and others cannot reach them.
- Do not let cord hang over the edge of the table or counter or touch hot surfaces. Do not use an extension cord.
- Remove the kettle from the kettle base before filling. Remove all moisture on the bottom of the kettle before placing it onto the kettle base.

IMPORTANT!

Use the kettle only with the delivered kettle base provided by Fellow. Do not use any other kettle on the delivered base, or any other base with the delivered kettle unless specifically provided and advised by Fellow.

Stagg EKG Pro's base and kettle are not compatible with the base or kettle of Stagg EKG, Stagg EKG+, Corvo EKG, or Stagg Pour-Over Kettle.

WARNING: Do not fill above the Maximum Fill Point as displayed in the diagram above. If the kettle is overfilled, hot water may be expelled, increasing the risk for scalding. See *Diagram B*, below, for reference. We suggest using only the amount of water you need to conserve water and energy.

WARNING: Do not operate dry or below the Minimum Fill Point.

Diagram B:
Fill Points

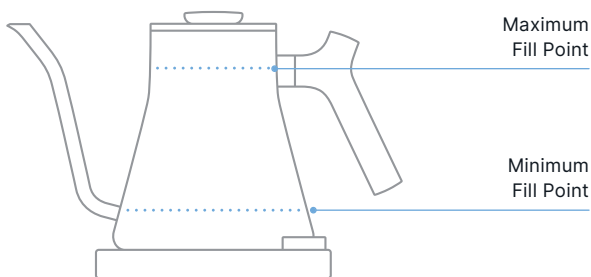

Stagg EKG Pro must have a minimum of 333 ml/11 fl oz to function. Dry boiling the kettle may result in permanent damage to the kettle and potential fire. The Minimum Fill Point is 1 inch (2.54 cm) above the floor of the kettle. See *Diagram B*, above, for reference.

WARNING! TO PREVENT SCALDING:

- Never use the kettle without its lid.
- Do not remove the lid while the kettle is boiling.
- Scalding may occur if the lid is removed during the heating and brewing process.
- Be aware of steam being emitted from the spout or lid especially during refilling.
- Water can remain hot for a long time after boiling and can present a scalding hazard. Keep the kettle and the kettle base away from the edge of the work surface and out of the reach of children. Do not remove the lid until the kettle cools down.

IMPORTANT SAFEGUARDS CONTINUED

- Kettle must be operated on a flat surface away from the edge of the counter to prevent accidental tipping.
- Never move the kettle and kettle base together while the unit is in use.
- To avoid burns and risk of personal injury, use extreme caution when carrying the kettle containing hot water.
- Do not use the kettle if your hands are wet.
- Position the kettle properly on the kettle base before switching on.
- After using the kettle, wait until the kettle has cooled down before removing the lid. To avoid possible steam damage, turn spout away from walls or cabinets during use.
- If setting down the kettle body on a table surface, use a protective pad under the kettle after it has been heated to prevent damage to surfaces.
- To reduce the risk of fire or electric shock, do not remove bottom cover from base or disassemble base or kettle in any way. There are no user-serviceable parts inside. Repair should be done by authorized service personnel only. Opening base or kettle will result in a void of the warranty.
- Do not operate in the presence of explosive and/or flammable fumes.
- Do not use the kettle for other than intended use. This appliance is intended for household and commercial use only. Use for anything other than intended use will void the warranty.

GROUNDING PLUG

This appliance has a grounded, three-prong plug and must be grounded with a three-prong outlet when in use. To ensure protection against risk of electric shock or fire, connect to properly grounded outlets only. Do not attempt to bypass this safety feature.

DO NOT HEAT AN EMPTY KETTLE

The concealed heating element in the bottom of the kettle body is protected by an automatic safety device. If your kettle is accidentally heated without being filled or is allowed to boil dry, it will automatically cool down and then turn off. If this happens, unplug the kettle, fill with cold water, and wait a few minutes before replacing it on the base and plugging in.

SAVE THESE INSTRUCTIONS

Diagram C:
Initial Use

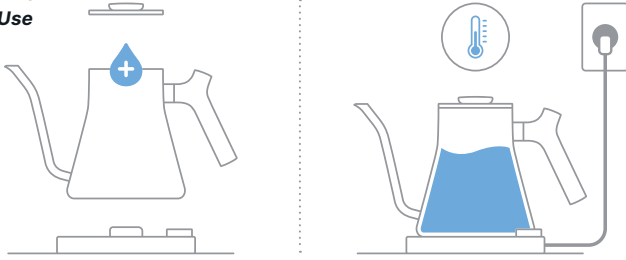

INITIAL USE

CLEANING – FIRST TIME USE

1. Place Stagg EKG Pro's base and kettle on a flat, level surface.
2. Remove kettle from the base and remove the lid to add water. (Do not remove the lid if the lid is hot.)
3. Rinse the interior of the kettle, then add water to the kettle until approximately halfway full (between the Minimum Fill Point and Maximum Fill Point in *Diagram B*).
4. After adding water, insert lid and ensure spout is not close to and/or facing a wall or cabinet.
5. Following the safety guidelines, plug the power-supply cord into wall outlet.
6. Set Goal temperature (see High Altitude Chart) to boil water.
7. Once Goal temperature (see High Altitude Chart) is reached, continue to boil water for approximately one minute. Turn off the kettle with a quick press of the dial. The LCD screen will turn black.
8. Discard the water inside the kettle. This water should not be consumed. Your Stagg EKG Pro is now ready to use.

CLEANING

Before cleaning, ensure the base is unplugged and the kettle has cooled completely. Empty any remaining water from the kettle.

CAUTION: Never immerse the kettle in water or other liquids. The could cause permanent damage to the kettle.

Do not place any parts of the kettle in a dishwasher.

Wipe the exterior of the kettle and base with a damp cloth or sponge, then dry.

Do not use abrasive soaps, cleansers, or scouring pads on any part of the kettle as it may damage the finish.

Over time, the kettle may lose the ability to reach boiling temperature. This may be due to scaling and mineral deposits which can build up on the inside of the kettle depending on your use and the hardness of water in your area. When this happens, use a scale/lime remover, following the scale/lime remover manufacturer's directions.

STORAGE

Clean and dry all parts before storing. Store the kettle in its box or in a clean, dry place.

Never wrap the power-supply cord around the kettle.

HOW TO USE

Please read this entire Safety and Maintenance manual fully before turning on and using your kettle.

CONNECT STAGG EKG PRO TO WIFI

The Fellow app is required for connectivity. Stagg EKG Pro does not connect automatically to WiFi.

1. Download the Fellow app onto your phone at [Fellowproducts.com/app](https://www.fellowproducts.com/app).
2. Ensure Stagg EKG Pro is plugged into an outlet.
3. Ensure Stagg EKG Pro is in an area with good WiFi coverage.
4. Know your WiFi network name and WiFi network password.
5. Open the Fellow app and follow the instructions in the app to connect.
6. For more information or troubleshooting your WiFi connection, please head to [Fellowproducts.com/pages/gear-guides](https://www.fellowproducts.com/pages/gear-guides).

TURN KETTLE ON/OFF

To turn Stagg EKG Pro on, press the menu button OR the dial and wait for the screen to light up. To turn Stagg EKG Pro off, press the dial and wait for the screen to turn black.

**Diagram D: ON/OFF,
Menu Access**

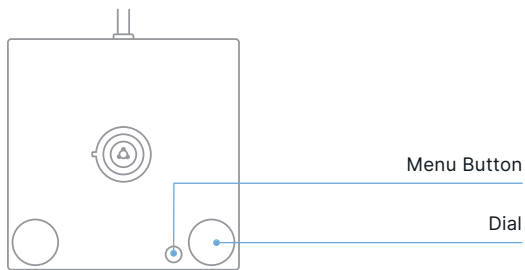

SET GOAL TEMPERATURE

From the main screen when Stagg EKG Pro is powered on, turn the dial to change the goal temperature. Turn the dial clockwise to increase the goal temperature. Turn the dial counterclockwise to decrease the goal temperature.

Once you arrive at your desired temperature, stop turning the dial. Stagg EKG Pro will display the set temperature for a moment and then begin heating to the desired temperature. If the kettle is ever removed and set back on the base, the kettle will start heating to your goal temperature right away.

IMPORTANT: If Pre-Boil is enabled, the kettle will first heat to boiling before cooling down to your goal temperature.

MENU ACCESS

Stagg EKG Pro has a host of brew tools. To enter the menu:

1. Press the dial to turn on your kettle and start warming-up water. The LCD screen will light up.
2. Press the menu button to navigate to the main menu.
3. Once within the main menu, rotate the dial clockwise or counterclockwise to navigate between the available menu options. Press the dial to enter or validate a choice.
4. Press the menu button to leave the menu.
5. Press the dial to turn off your kettle. The LCD screen will turn black.
6. To see more details on the menu please visit [Fellowproducts.com/pages/gear-guides](https://fellowproducts.com/pages/gear-guides) or scan this QR Code.



HIGH ALTITUDE USE

CAUTION: Water boils at lower temperatures in higher altitudes (see *High Altitude Chart*). If the Set temperature is higher than the boiling point of water at a given altitude, Stagg EKG Pro will continue to provide heat to attempt to reach the Goal temperature. This causes excess energy usage and potential damage to the kettle. Using the **Altitude** setting, Stagg EKG Pro will determine the maximum allowable target temperature based on the user-input altitude to mitigate energy waste and risk of kettle damage.

HIGH ALTITUDE CHART

Altitude, ft (m)	Boiling Point Of Water, °F (°C)
0 ft (0 m)	212°F (100°C)
500 ft (150 m)	211.1°F (99.5°C)
1,000 ft (305 m)	210.2°F (99°C)
2,000 ft (610 m)	208.4°F (98°C)
5,000 ft (1524 m)	203°F (95°C)
6,000 ft (1829 m)	201.1°F (94°C)
8,000 ft (2438 m)	197.4°F (91.9°C)
10,000 ft (3048 m)	193.6°F (89.8°C)
12,000 ft (3658 m)	189.8°F (87.6°C)
14,000 ft (4267 m)	185.9°F (85.5°C)

SERVICE

For service or any questions regarding your appliance, first visit, **help.fellowproducts.com**. If you still have questions, reach out to us at **hello@fellowproducts.com**.

Do NOT mail the product back to the manufacturer or bring it to a service center without first talking to a Fellow customer service representative.

2-YEAR LIMITED WARRANTY

Fellow warrants this product against any defects that are due to faulty material or workmanship for a two-year period after the original date of consumer purchase.

This warranty is valid only for:

- The original consumer.
- Kettles purchased through authorized retailers.
- Kettles with the original sales receipt for proof of purchase.

This warranty does not include damage to the product resulting from:

- Accident, misuse, or repairs performed by unauthorized personnel.
- Operation with the wrong type of current or voltage.
- Failure to follow cleaning instructions for both the kettle and cleaning/descaling agents.
- Failure to comply with any safeguards listed in the warnings and instructions of this document.

If the product should become defective within the warranty period, or you have questions regarding warranty or service, email us at **hello@fellowproducts.com**.

Find more information at:

Fellowproducts.com/pages/stagg-ekg-GTKYG