

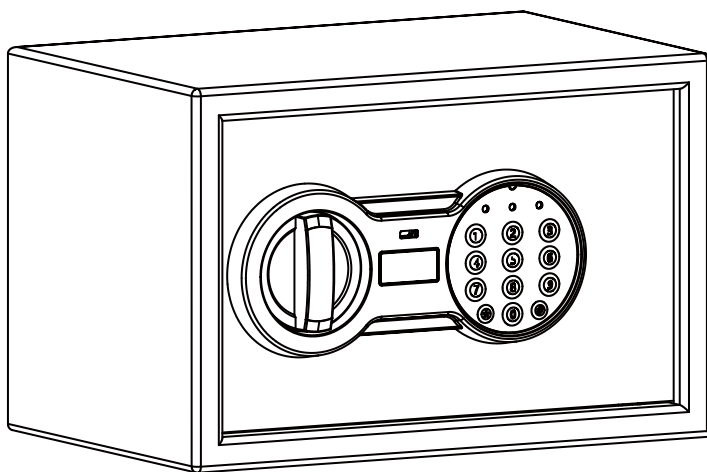

bonsaii

Instruction Manual DIGITAL SAFES WITH ELECTRONIC LOCK (SF001/SF002/SF003)



**THIS INSTRUCTION BOOK LET CONTAINS IMPORTANT SAFETY INFORMATION.
PLEASE READ AND KEEP IT FOR FUTURE REFERENCE.**

Please give us a chance to make it right and do better!
Contact our friendly customer service department for help first.
Replacements for missing or damaged parts will be shipped.

Customer Service:
✉ : customer-care@bonsaii.com
☎ : 1-844-728-6917

Safety and Compliance

1. Read this instruction manual carefully before using the appliance. Familiarize yourself with the operation, adjustments and functions of switches. Understand and follow the safety and operation instructions in order to avoid possible risks and hazards. Keep for future reference. If you give this device to someone else, this instruction manual must be included too.
2. Do not leave safe unattended while open.
3. Keep Children Away from safe.
4. Keep your safe locked and closed at all times when not in use. Store the emergency keys in a secret and safe place.
5. Place the product on a stable, secure place, possibly not elevated, lest it may fall over and suffer damages or cause injury to people.
6. Remember to record the serial number of your safe. You will need this serial number for all warranty or customer service inquiries.
7. Electronic media, photographic media and all audio-visual media should not be stored in the safe for fire protection.
8. Keep liquids away from the control panel and battery compartment. Liquids spilling over the electronic parts may cause damage and lead to malfunctioning.
9. Never attempt to dismantle the product by yourself.
10. If maintenance is required, please contact the local service center or local distributor.

Battery safety advice

1. Danger of explosion if the battery is replaced with one of the wrong types.
2. Replace the battery only with the same or equivalent type.

A WARNING

1. Do not swallow the battery, there's risk of chemical burns.
2. The batteries (battery block or built-in batteries) must not be exposed to excessive heat, i.e. direct sunlight, fire or the likes.
3. If a battery gets swallowed, can cause internal burns and cause death within 2 hours.
4. Keep new and used batteries out of the reach of children.
5. If the battery compartment doesn't close properly, stop using the product and keep it out of the reach of children.
6. If you think that the batteries were swallowed or introduced in any part of the body, seek medical attention immediately.
7. Leaking battery add may cause harm.

8. If batteries should leak, remove them with a cloth from the battery compartment. Dispose of batteries according to the regulations.
9. If battery acid has leaked avoid contact with skin, eyes and mucous membranes. Rinse affected areas immediately after contact with the acid and wash with plenty of clean water. Visit a physician.
10. Do not allow children to replace batteries without adult supervision.
11. Batteries may not be charged, re-activated by other means, disassembled, thrown into fire or short-circuited.

Schematic drawing of safe

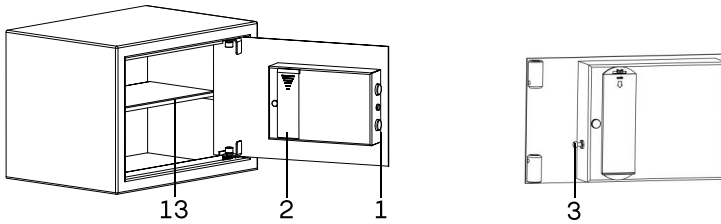

Schematic drawing of control panel

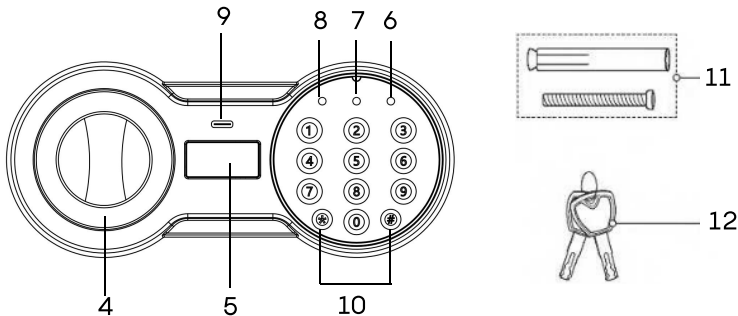

- | | |
|------------------------------|-----------------------|
| 1. Bolts | 6. Yellow Light |
| 2. Battery Compartment | 7. Red Light |
| 3. Reset Button | 8. Green Light |
| 4. Knob | 9. USB Type-C |
| 5. Emergency lock | 10. Confirming button |
| 11. Expansion bolts*2 | 12. Emergency key*2 |
| 13. Laminate*1 (SF002/SF003) | |

OPENING THE SAFE FOR THE FIRST TIME

NOTICE: To open the safe the first time you will need to use the emergency key.

NOTICE: The default preset passcode is "159", change it immediately.

1. Remove the Emergency lock.

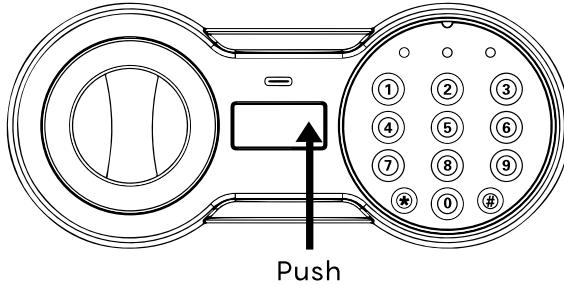

2. Insert the back up key (13) into the keyhole and turn counterclockwise.

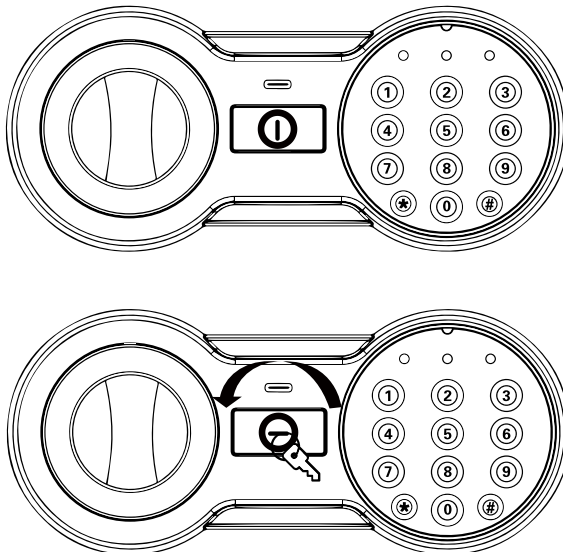

3. turn the knob clockwise to open the door.

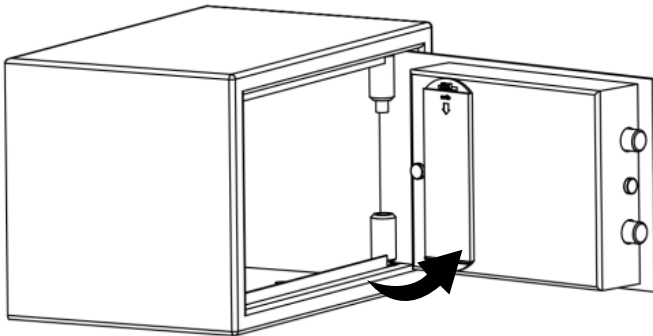
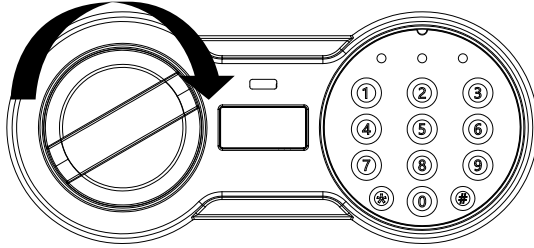

4. Open the battery compartment (2) and insert 4 x AA batteries (not included).

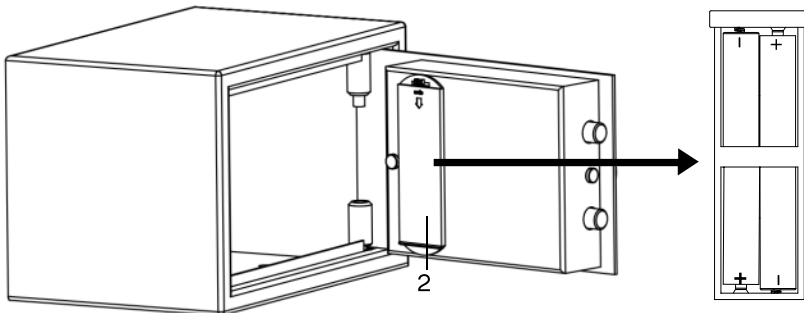

NOTICE: When the yellow and green lights come on at the same time, open the battery cover (2) and replace the battery.

NOTICE: Do not mix old and new batteries.

NOTICE: Do not mix alkaline, standard (carbon-zinc), or rechargeable (ni-cad, ni-m, etc.) batteries.

NOTICE: In case of battery failure, an external power supply (5V) is connected to the Type-C port to power the safe.

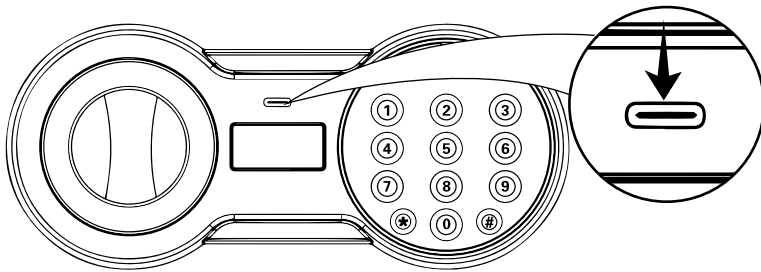

5. Set Pass code

① Open the door and press the reset button (3). The safe will make two beeps and the yellow light will flash. After the reset is successful, the yellow light is steadily on.

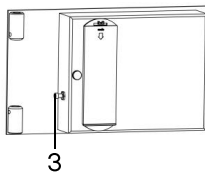

② Enter your passcode (must be 3-8 digits). And press " # " Store the password. There will be another 2 audible beeps and the yellow light flashes. This means your passcode has successfully been entered.

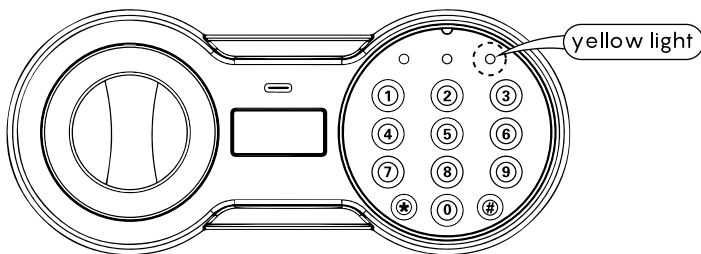

NOTICE: If you forget your code, you can use your back up keys at any to open your safe and reset the code.

NOTICE: Test the new passcode with the door open before locking the door.

TO REPLACE THE BATTERIES

If the Yellow Light and the Green Light are both lit at the same time, it is time to Replace the Batteries. Follow the instructions for opening the Safe. The Battery Compartment is located on the inside of the Door. Open the Battery Cover off of the Battery Compartment, remove the used Batteries, and insert four new "AA" Batteries. Once you have changed the Batteries, be sure to test the Code before you close the Door again.

Note: The original password will be invalidated after replacing the battery, and a new password needs to be set.

When the battery is out of power, and can't open door by Keypad lock, there is a USB port that can be used to connect the power bank to power up. Next, you can use the keypad lock to unlock and replace the battery.

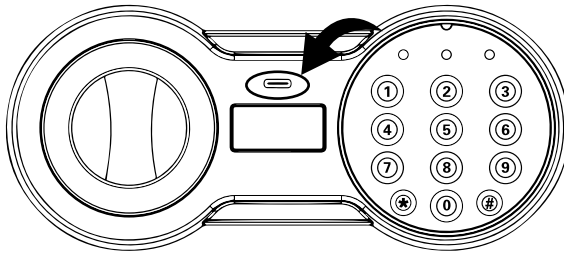

Warning: Do not mix old and new batteries.

Warning: Do not mix alkaline, standard (carbon-zinc), or rechargeable (ni-cad, ni-m, etc.) batteries.

UNLOCKING THE SAFE

1. Input your new passcode (3-8 digits).
2. Press "*" to confirm, the green light flashes and turn the knob clockwise to open the safe.
3. If yellow indicator light flashes with 3 audible beeps, your passcode was not entered correctly, please input your passcode again.

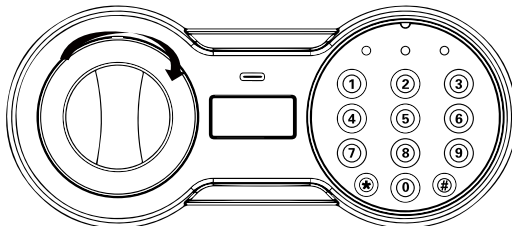

NOTE: If 3 invalid passcode attempts are made in succession, this will cause the keypad to beep and the yellow indicator flashes for 23 seconds and lock the user out for 23 seconds. You can still use your backup key at any time to open the safe.

LOCKING THE SAFE

To lock your safe, simply close the door and turn the knob counterclockwise.

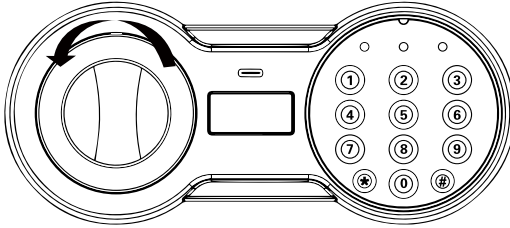

SECURING THE SAFE TO A FLOOR OR WALL

Select a stable, dry and secure location for your safe. If bolting to a wall, make sure that your safe is resting on a supporting surface (such as the floor or a shelf). Do not bolt your safe to both the floor and wall.

1. Place the safe on the selected location. Use a pencil to mark the mounting holes on the floor or wall.
2. Move the safe and drill 2.4-inch-deep mounting holes (~60 mm) using a 10 mm drill bit.
3. Put the expansion bolt (included) into the mounting hole, then turn the clamping screw counterclockwise to separate.

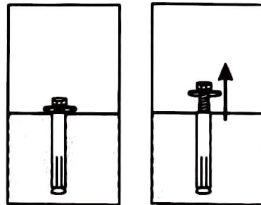

4. Move the safe back in place, align the safe over the holes. Then secure the safe with the clamping screw.

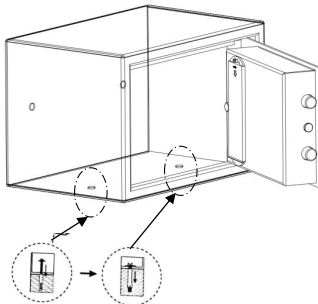

Cleaning and Maintenance

1. If necessary wipe the outside and inside of the product with a slightly damp cloth.
2. Avoid contact with corrosive substances like acids, alkaline or similar substances.

Troubleshooting

Problem	Solution
The safe won't open when entering the passcode.	<ol style="list-style-type: none">1. Make sure you entered the correct passcode.2. Enter the password and press #.3. Replace the batteries.
The door won't shut.	<ol style="list-style-type: none">1. Make sure there are no obstructions.2. If the door bolts (1) are extended, re-enter the passcode and turn the knob (4) clockwise to retract them.
The yellow light and the green light went on at the same time	Replace the batteries.
The yellow light blinks and beeps three times	Make sure you entered the correct passcode. Enter the password and press#.

Environmental Protection



This marking indicates that this product should not be disposed with other household wastes throughout the EU. To prevent possible harm to the environment or human health from uncontrolled waste disposal, recycle it responsibly to promote the sustainable reuse of material resources. To return your used device, please use the return and collection systems or contact the retailer where the product was purchased. They can take this product for environmental safe recycling.



Used batteries must not be disposed of through household garbage, since they might contain toxic elements and heavy metals that can be harmful to the environment and human health.

Consumers are therefore obligated to return batteries to retail or local collection facilities free of charge. Used batteries will be recycled.

They contain important raw materials such as iron, zinc, manganese or nickel. The crossed-out wheellie bin symbol indicates: Batteries and rechargeable batteries must not be disposed of through household garbage.

The symbols below the wheellie bin indicate:

Pb: Battery contains lead

Cd; Battery contains cadmium

Hg: Battery contains mercury



The packaging consists of cardboard and correspondingly marked plastics that can be recycled. Make these materials available for recycling.

FCC Compliance Statement

1. This device complies with Part 15 of the FCC rules. Operation is subject to the following two conditions:
 - (1) this device may not cause harmful interference, and
 - (2) this device must accept any interference received, including interference that may cause undesired operation.
2. Changes or modifications not expressly approved by the party responsible for compliance could void the user's authority to operate the equipment.

FCC Interference Statement

This equipment has been tested and found to comply with the limits for a Class B digital device, pursuant to part 15 of the FCC Rules. These limits are designed to provide reasonable protection against harmful interference in a residential installation. This equipment generates, uses and can radiate radio frequency energy and, if not installed and used in accordance with the instructions, may cause harmful interference to radio communications. However, there is no guarantee that interference will not occur in a particular installation. If this equipment does cause harmful interference to radio or television reception, which can be determined by turning the equipment off and on, the user is encouraged to try to correct the interference by one or more of the following measures:



- Reorient or relocate the receiving antenna.
- Increase the separation between the equipment and receiver.
- Connect the equipment to an outlet on a circuit different from that to which the receiver is connected.
- Consult the dealer or an experienced radio/TV technician for help.

Disposal



The Waste Electrical and Electronic Equipment (WEEE) Directive aims to minimize the impact of electrical and electronic goods on the environment, by increasing re-use and recycling and by reducing the amount of WEEE going to landfill. The symbol on this product or its packaging signifies that this product must be disposed of separately from ordinary household wastes at its end of life. Be aware that this is your responsibility to dispose of electronic equipment at recycling centers in order to conserve natural resources. Each country should have its collection centers for electrical and electronic equipment recycling. For information about your recycling drop off area, please contact your related electrical and electronic equipment waste management authority, your local city office, or your household waste disposal service.

Specifications

Model No.	SF001	SF002	SF003
Power supply	4x 1.5 V  , (AA) (not included) 5 V  , (backup supply)		
Dimensions	171*260*171mm (6.73*10.27*6.73inches)	350*250*250mm (13.78*9.84*9.84inches)	330*330*360mm (12.99*12.99*14.17inches)
Weight	3.5KG/7.72lbs	7.6KG/16.76lbs	10.7KG/23.59lbs
Capacity	5.8L/1.6Gallon	18.02L/4.76Gallon	34.4L/9.09Gallon

LIMITED WARRANTY

We stand by our product and offer a 30-day money-back guarantee. During this time, you could return the item without paying any extra fee if there is a manufacturing defect in it. Please rest assured that the returns are free and easy if there is a manufacturing defect. Otherwise, it would be the customer's responsibility to cover the shipping fee. Products on sale are also returnable.

If the product isn't meeting your expectations, please email within 30-days of receipt. We will help you to either return or exchange your product. Your original form of payment will be refunded in full once the full return is complete. After 30-days orders may be subject to a 20% restocking fee and all shipping and handling charges will be the responsibility of the customer. Additional return details are listed below. After 60-days the purchase from Bonsaii is non-refundable.

If you receive a damaged product, you must notify Bonsaii within 48 hours of delivery. Bonsaii will investigate the claim and notify the freight company about the damage. Please retain all packaging in the event that Bonsaii or the freight company needs to inspect it. These investigations may take several days but merchandise replacements will be processed as soon as possible.

For product arrived defective or damaged, We're sorry to hear that your Bonsaii product arrived in less than perfect condition. We'd like to resolve this issue right away with the help of our Customer Support Team and Quality Assurance team. They'll need to know a bit of information on your order as well as the issue you're experiencing with your Bonsaii product. To report your issue, please reach out to our Customer Support team by emailing customer-care@bonsaii.com with your order number. We may need you to make a short video, or take some pictures of the defects of the product and send them to customer-care@bonsaii.com. After a preliminary analysis on the video or pictures, we will send you a brand new replacement right away if it is confirmed to be defective on its arrival. If we determine that you have misrepresented Bonsaii product's condition and that product is not defective, we will send you the right instructions and help you to use the product correctly.

If you have any questions or any confusions, Please kindly contact with us:
customer-care@bonsaii.com.



Manufacture: Bosen Electronics Limited

📍 : No.11-12, Lun Pin Chong Industrial Zone San Tun
Community, Hou Jie Town 523941 Dongguan City,
Guangdong PEOPLE'S REPUBLIC OF CHINA

☎ : 1-844-728-6917

✉ : customer-care@bonsaii.com

Made in Vietnam