

A

# ADVENTURE TRI-BUNK BED

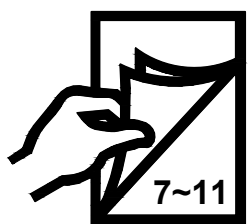

B

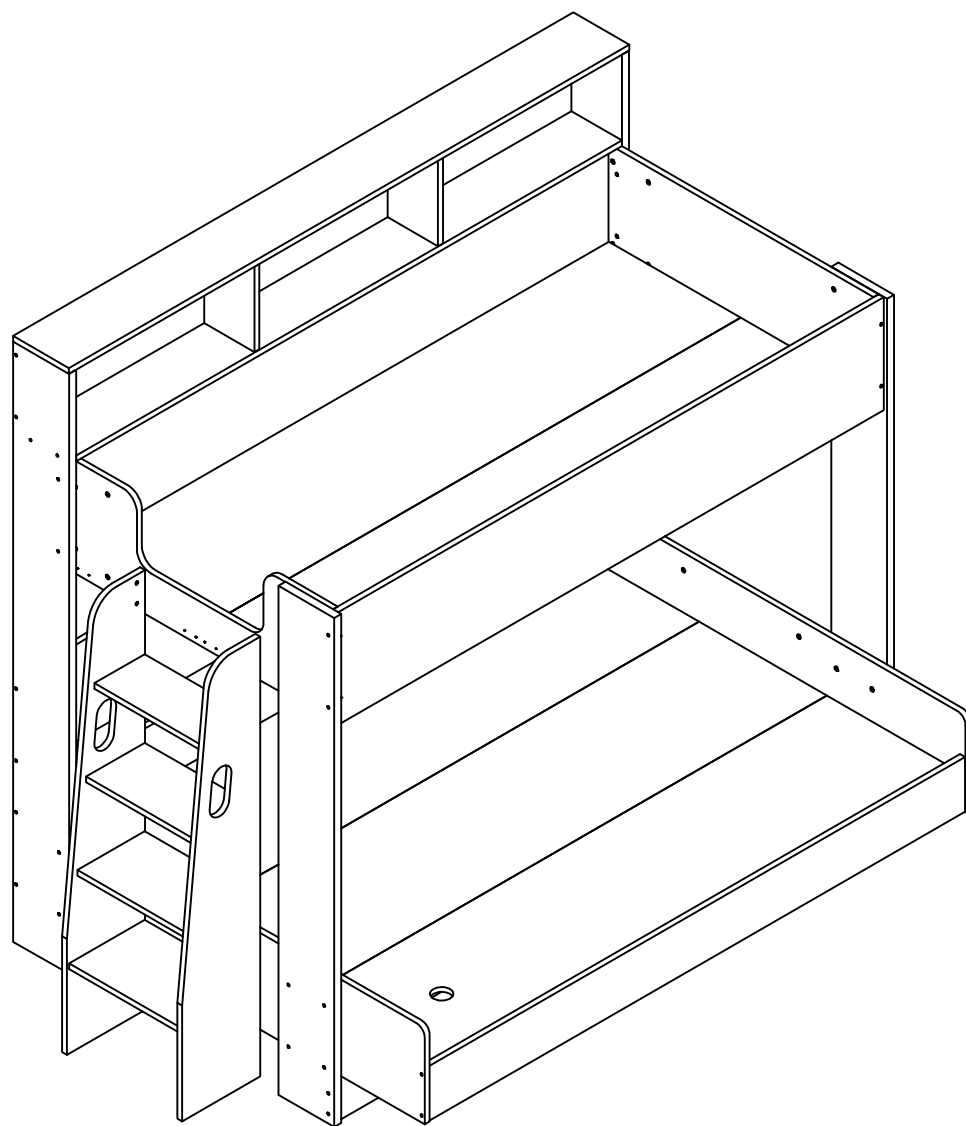
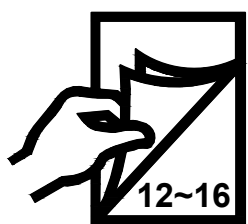
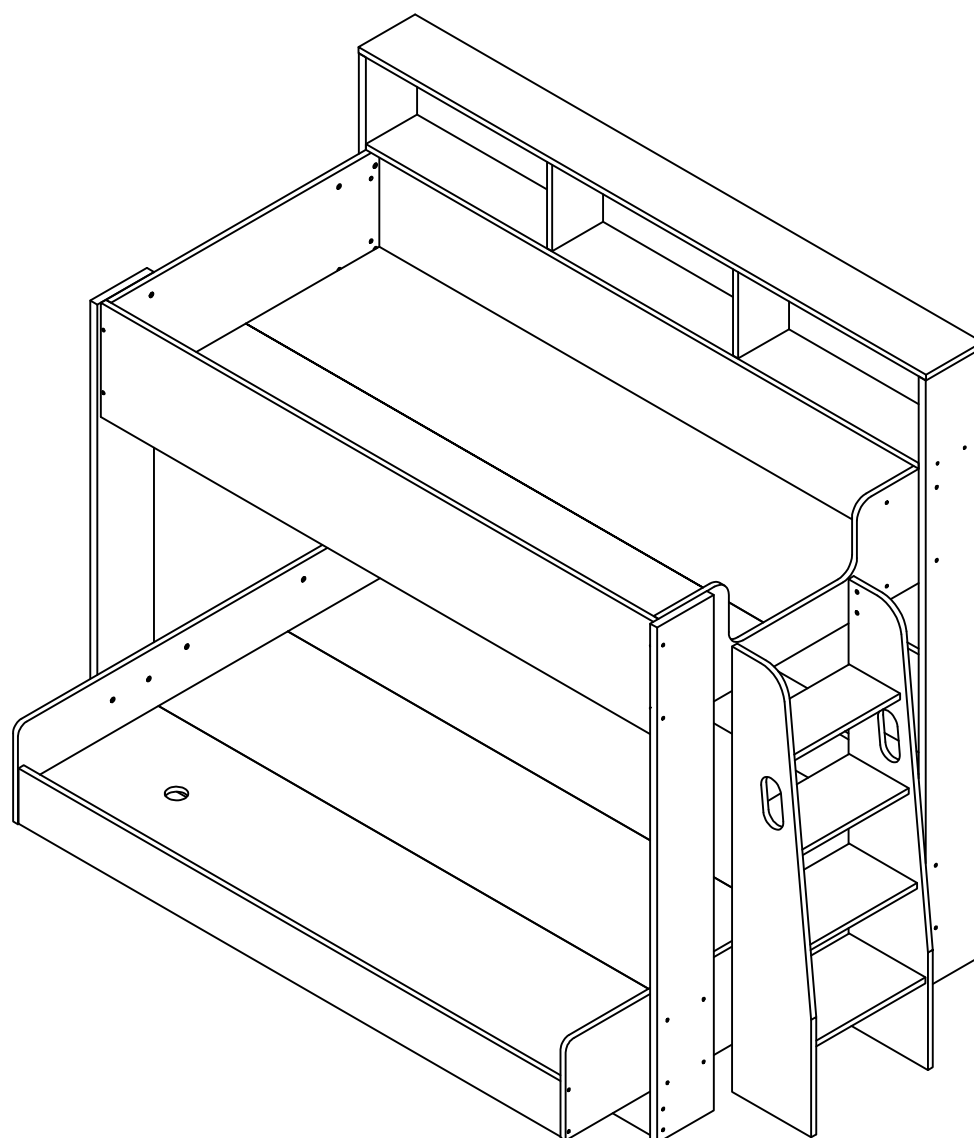

# little whitehouse

Thank you for purchasing your new furniture from us. We know you are very excited to start using it. We would first however, like to draw your attention to some safety aspects of using a bunk bed.

General Care & Safety for furniture.,

Safety:

- Please note that this product ships flat-pack and requires self-assembly by at least 2 persons.
- Please ensure that all fittings are in place and kept tightened at all times as loose fittings may result in injury or damage to the furniture.
- This product is not intended for use in any other way than indicated on the assembly instructions. Incorrect use, playing, climbing or jumping on this furniture may result in damage to the components or injury to the child.
- Please be aware of small parts which small children could swallow prior to assembly or plastic bags and other packaging that could suffocate or hurt small children. Discard all plastic & other packaging after assembly.
- Do not attempt to move the furniture in an assembled state as structural damage may occur.
- Be sure to keep all fittings when moving as the same fittings may not be attainable at a later stage.
- Mount high furniture to the wall to avoid tipping over.
- Only open one drawer at a time on furniture that has more than one drawer to avoid tipping over.
- Place heavier items at the bottom of furniture to avoid tipping.
- Make sure that there are no slam hazards on drawers or doors which could result in fingers being trapped.

Please do not hesitate to contact us should you have any questions.

The little whitehouse Team  
hello@littlewhitehouse.co.za  
www.littlewhitehouse.co.za

**CLM HOME (PTY) LTD - Reg 2013/045245/07**

Unit 6B, Tygerberg Business Park, 6 Koets St, Parow Industrial, Cape Town, 7493  
Directors: H Kahn, JM Kahn and W Dijkman

# little whitehouse

## HOW TO USE A BUNK BED

### Assembly:

- Please note that this product ships flat-pack and requires self-assembly by at least 2 persons.
- Please ensure that all fittings are in place and kept tightened at all times as loose fittings may result in injury or damage to the furniture.
- Please be aware of small parts which small children could swallow prior to assembly or plastic bags and other packaging that could suffocate or hurt small children. Discard all plastic & other packaging after assembly.
- Do not attempt to move the furniture in an assembled state as structural damage may occur.
- Be sure to keep all fittings when moving as the same fittings may not be attainable at a later stage.

## USING A BUNK BED SAFELY

This product is not intended for use in any other way than indicated on the assembly instructions. Incorrect use, playing, climbing or jumping on this furniture may result in damage to the components or injury to the child.

- Children must be at least 6 years old before they can use the top bunk.
- Children should always use the ladder/staircase when getting on or off the top bunk
- Only 1 person should be on the top bunk at a time.
- Only play under a top bunk bed if the lower space is designed by the manufacturer as a play area.
- Keep large toys or heavy objects off the top bunk.
- Never tie anything to the bed. Belts, cords, sashes, scarves or ropes can strangle a child.
- Use guardrails on both sides of the top bunk. The gaps in the guardrails should be 90mm or smaller to prevent strangulation.
- Guardrails need to extend at least 127mm above the mattress top to prevent kids from rolling off.
- Check that the mattress foundation is strong and that the right mattress size is used.

**CLM HOME (PTY) LTD - Reg 2013/045245/07**

Unit 6B, Tygerberg Business Park, 6 Koets St, Parow Industrial, Cape Town, 7493

Directors: H Kahn, JM Kahn and W Dijkman

# little whitehouse

- Keep the top bunk at least 2m away from ceiling fans.
- Install a night light near the ladder.
- Do not use the bunk bed or ladder if any parts are damaged or broken.
- Teach kids how to carefully climb the ladder.
- Keep bunk beds away from window blinds or curtains with cords. This is to avoid children becoming entangled and possibly strangled.
- Check regularly to make sure the bed frame is sturdy and free from signs of wear and tear.
- Put carpet under the bunk bed - research shows that carpet around bunk beds can decrease the risk of head injury from a fall.
- Keep the area under the bunk bed clear of furniture, toys and sharp objects.
- Check for any gaps that may trap fingers, limbs or heads. Make sure there are no gaps between 95-230mm anywhere on the bed. These could trap your child's head. In other words, gaps should be smaller than 95mm so a child's body can't fit through or larger than 230mm so a child's body can fit all the way through.

A gap might involve:

- guardrails
- the edge of the mattress
- the bedposts, mattress slats or other structural parts
- the ladder
- any other parts

Most reported injuries from bunk beds are due to:

- Falls from the top bunk while sleeping or playing.
- Children getting their heads or bodies caught between the mattress and the bed.
- Children becoming trapped between different parts of the bed.
- Injuries from bunk beds are usually worse than injuries from standard beds
- Cuts are the most common injury, followed by bumps, bruises and broken bones.
- The head & neck are injured the most.

**CLM HOME (PTY) LTD - Reg 2013/045245/07**

Unit 6B, Tygerberg Business Park, 6 Koets St, Parow Industrial, Cape Town, 7493

Directors: H Kahn, JM Kahn and W Dijkman

# little whitehouse

## WHAT TO LOOK FOR WHEN CHOOSING A BUNK BED:

When you are choosing a bunk bed for your home, make sure it is sturdy and safe.

- Purchase a bunk bed that meets the latest safety standard.
- Check that the bed comes with instructions for assembly and use, and is undamaged (for example, make sure there are no cracks in welds on a metal bed)
- Make sure the top bunk has guardrails on all sides, even if the bed will be placed against a wall
- You need a guardrail on the wall-side of a bunk bed, unless the bed is permanently attached to the wall (or built into it) or the wall is free of gaps, protrusions or other hazards.
- Make sure corner posts and ladders do not extend more than 5mm above the guardrails or end panels. This is to reduce risk of clothes being caught.
- Make sure the ladder is securely attached to the bed and in good condition. Never remove it for any reason.
- If replacement parts are needed, only use those from the original manufacturer. Never substitute parts from a different bed.
- Get the right mattress.
- Make sure your mattress is the correct size and thickness for your model of bunk bed.
- Check that the mattress fits snugly against all four sides of the bed. It should also be at least 127mm below the top guardrails and end panels.













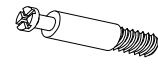

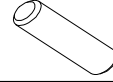

Please do not hesitate to contact us should you have any questions.

The little whitehouse Team  
hello@littlewhitehouse.co.za  
www.littlewhitehouse.co.za

**CLM HOME (PTY) LTD - Reg 2013/045245/07**

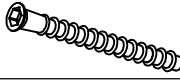
Unit 6B, Tygerberg Business Park, 6 Koets St, Parow Industrial, Cape Town, 7493

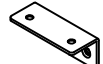
Directors: H Kahn, JM Kahn and W Dijkman

A		∅15x12	32	PCS	J		M6*30	32	PCS
B		∅7x35	32	PCS	K		M6*60	24	PCS
C		∅8x30	38	PCS	L		M6*55	24	PCS
D		∅18x4	12	PCS	M			48	PCS
E		∅4x16	64	PCS	N		M6*15	24	PCS
F		20x20x2	16	PCS	O		∅7*48	12	PCS
G		∅20	80	PCS	P		∅7*58	4	PCS
H		4MM	1	PC	Q		M6*18	12	PCS
I		60*25*25	8	PCS	R			1	PC

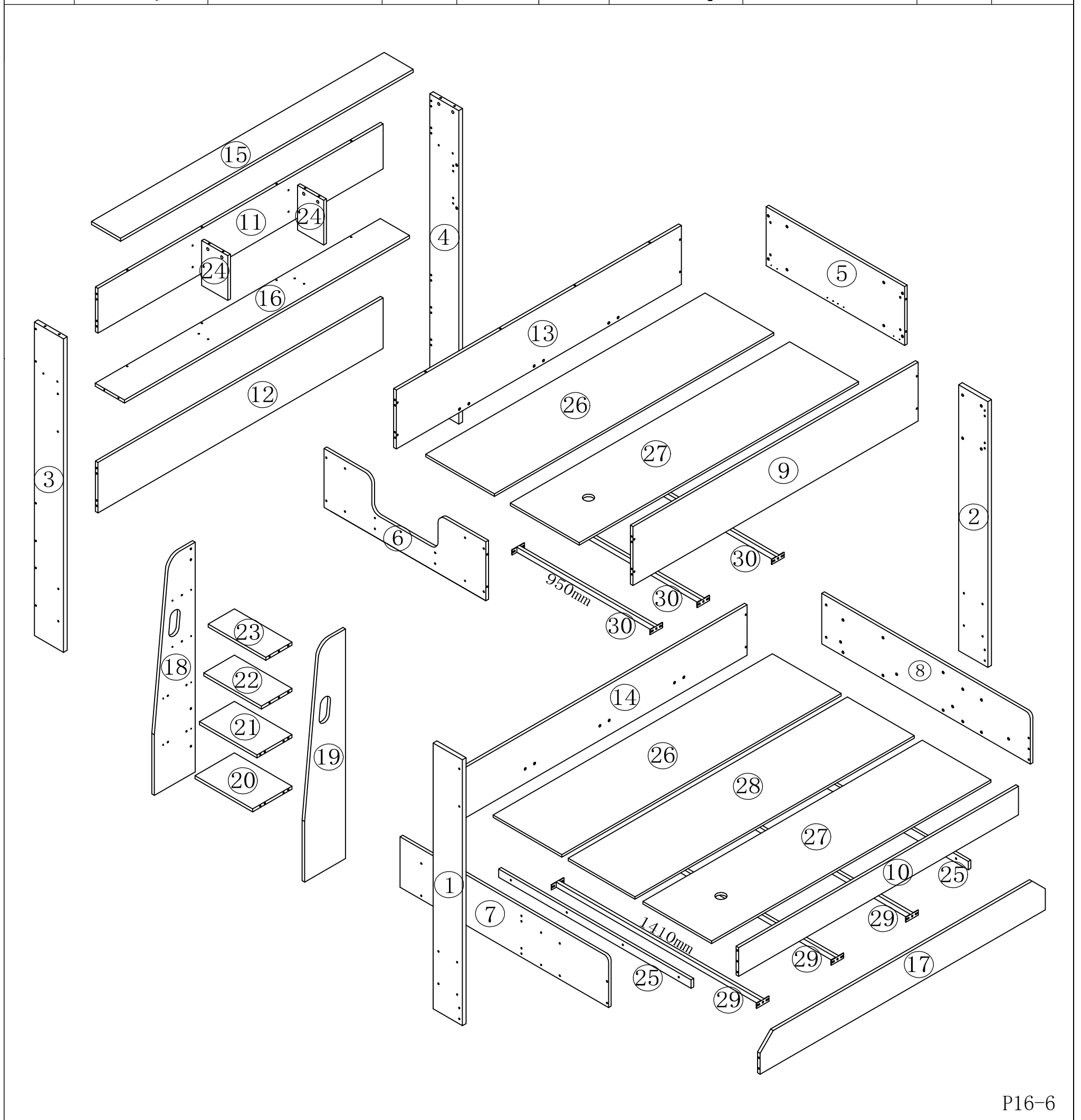

A1

- B  $\varnothing 7.8 \times 35$   
x16
- D  $\varnothing 18 \times 4$   
x4

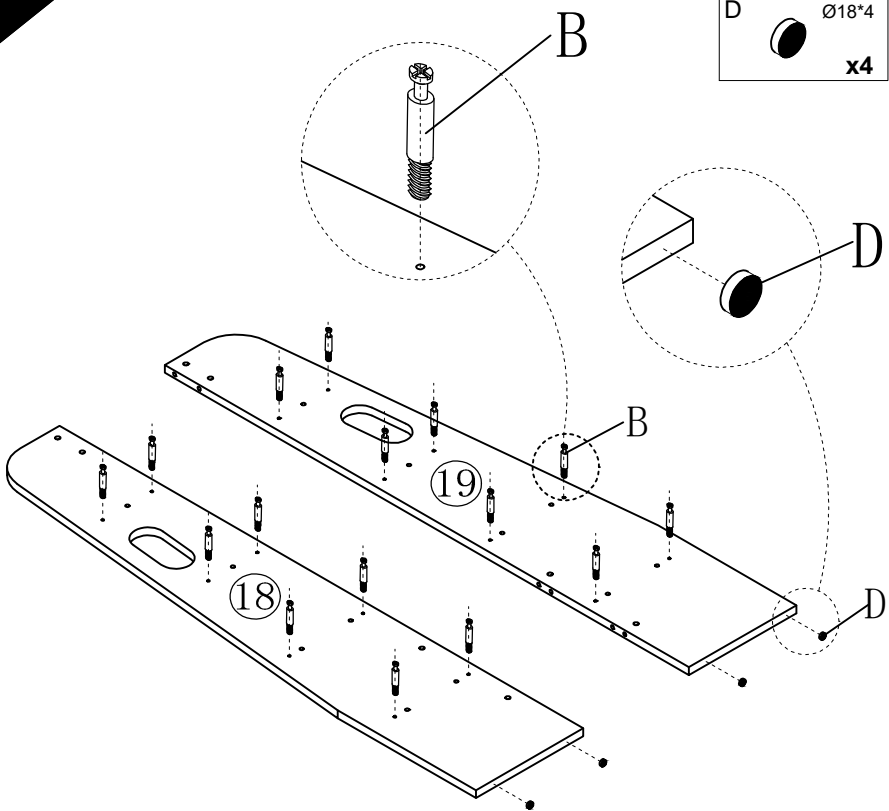

A2

- E  $\varnothing 4 \times 16$   
x16
- F  $20 \times 20 \times 2$   
x16

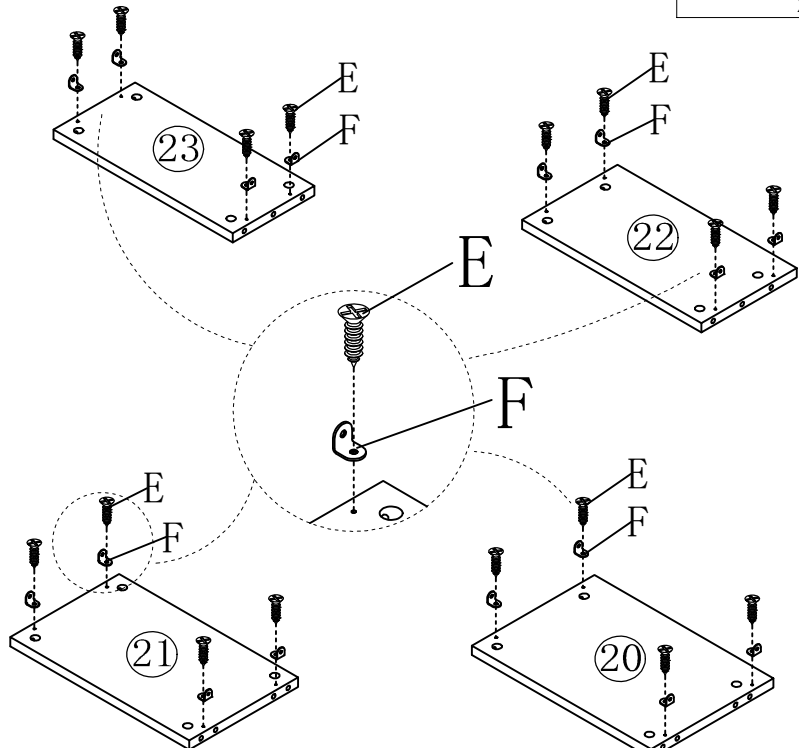

A3

- A  $\varnothing 15 \times 12$   
x8
- C  $\varnothing 8 \times 30$   
x6

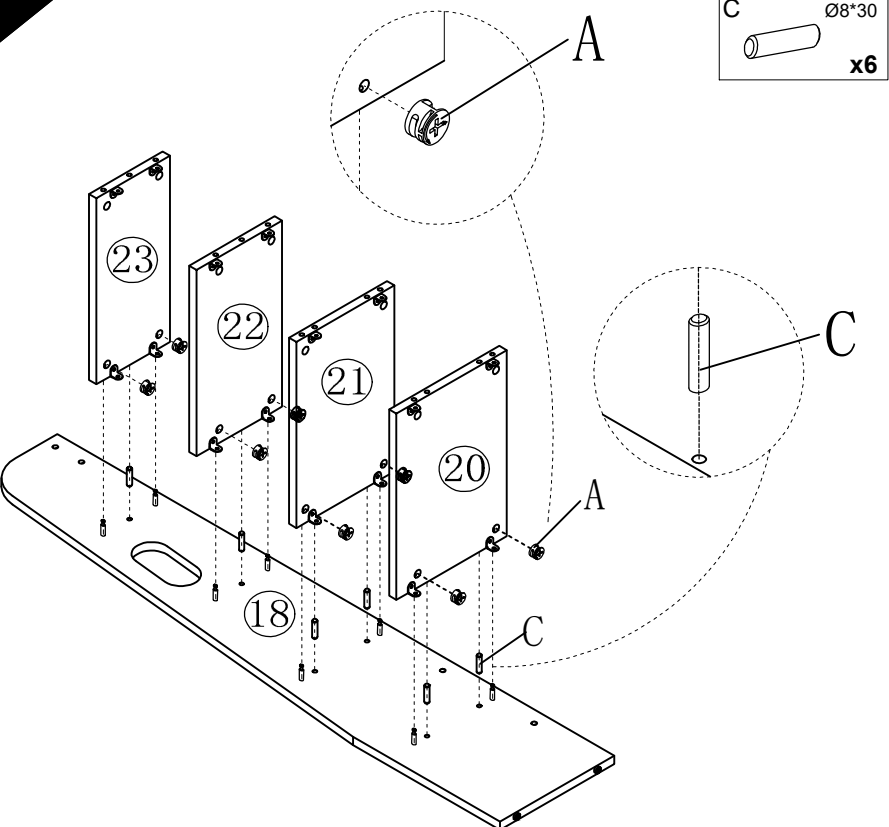

A4

- A  $\varnothing 15 \times 12$   
x8
- C  $\varnothing 8 \times 30$   
x6

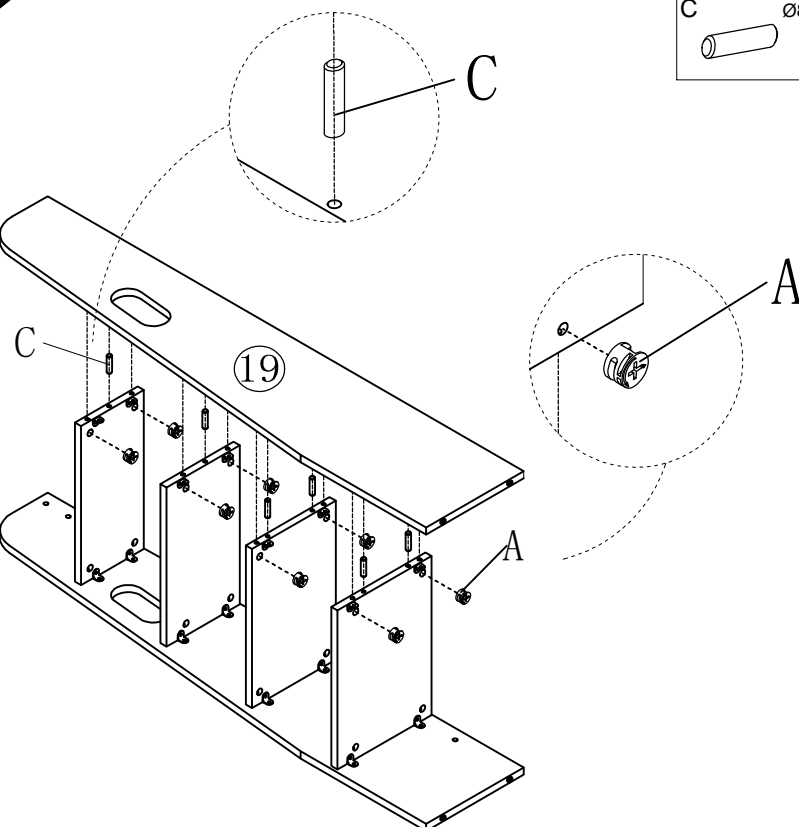

A5

- E  $\varnothing 4 \times 16$   
x16

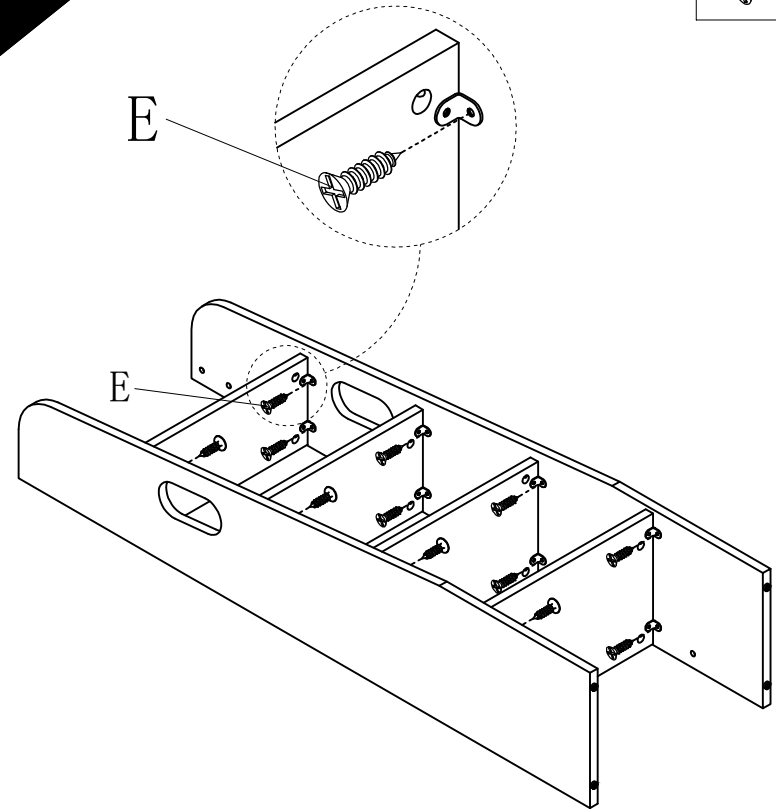

A6

- D  $\varnothing 18 \times 4$   
x4
- H 4MM  
x1
- J M6\*30  
x12
- Q M6\*18  
x6

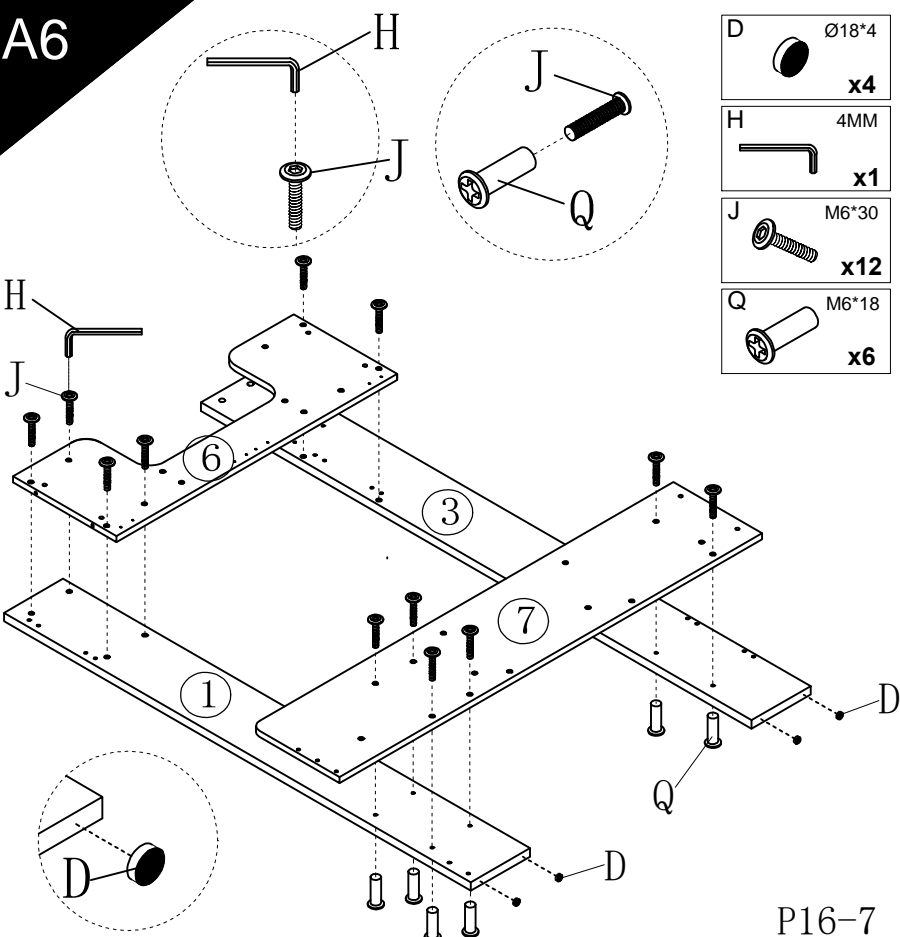

A7

J M6\*30 x4

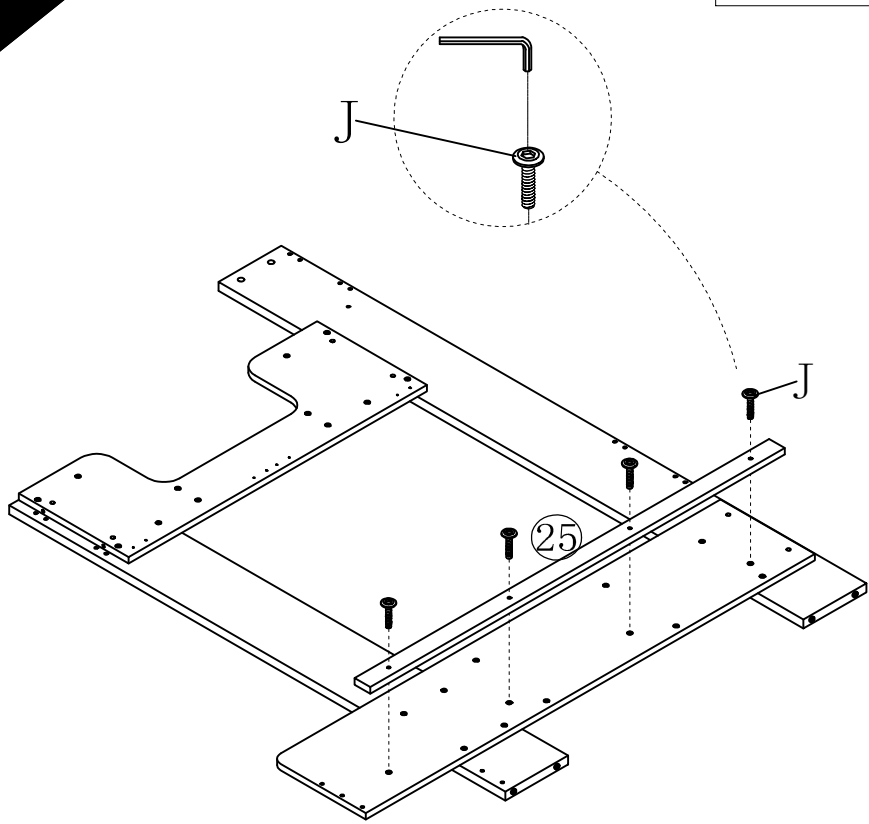

A8

D Ø18\*4 x4  
 J M6\*30 x12  
 Q M6\*18 x6

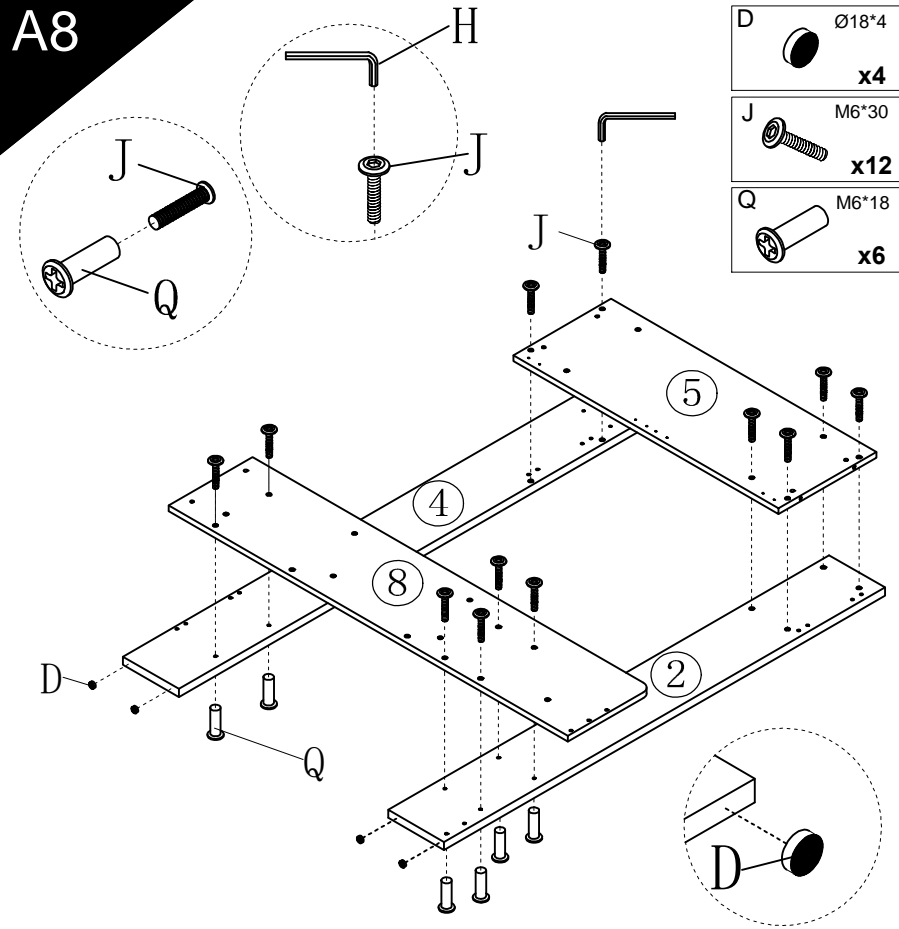

A9

J M6\*30 x4

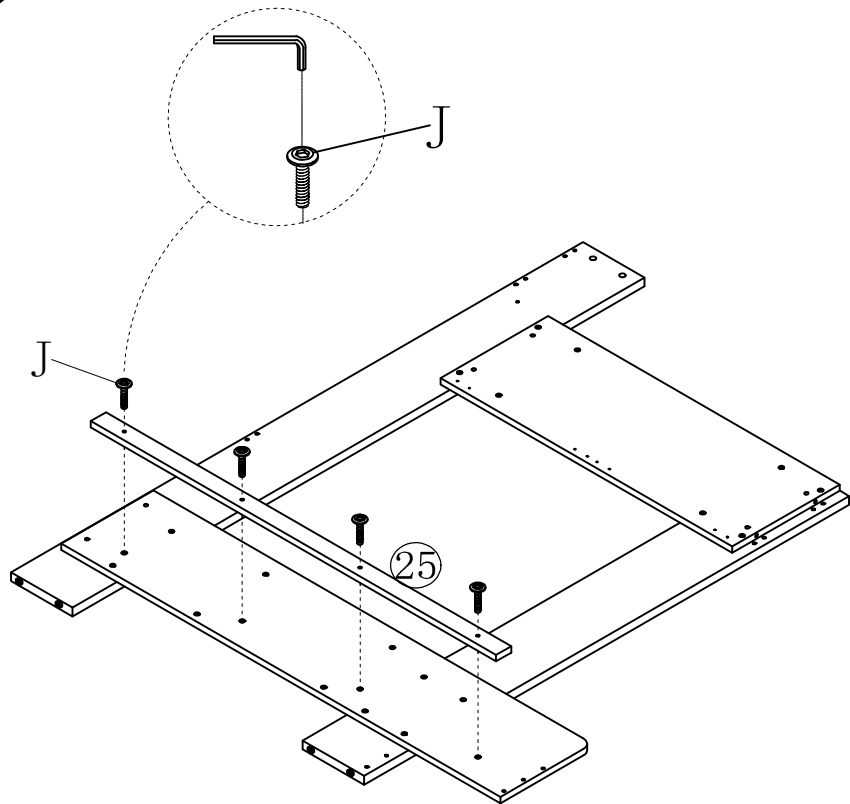

A10

B Ø7.8\*35 x4  
 O Ø7\*48 x4

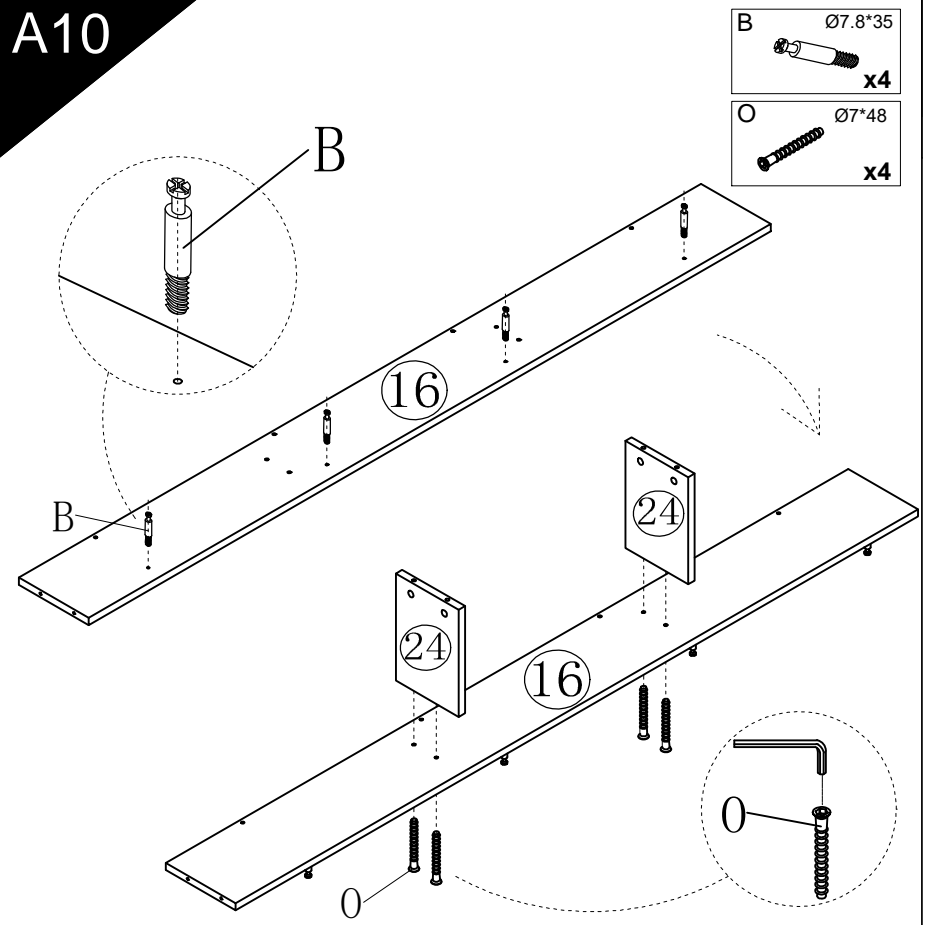

A11

O Ø7\*48 x8

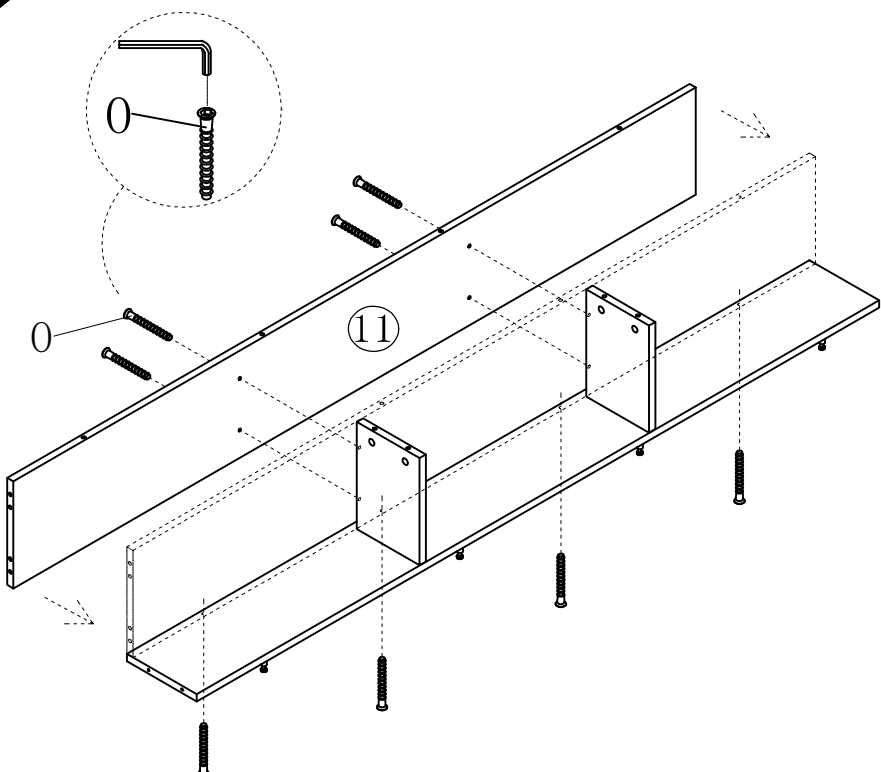

A12

A Ø15\*12 x4

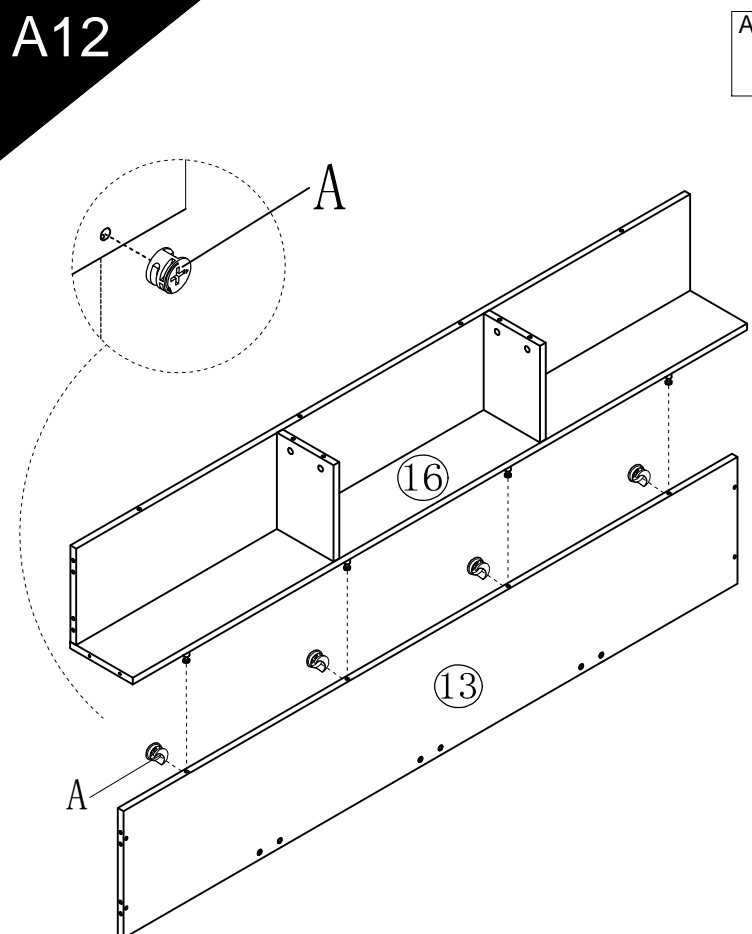



# A13

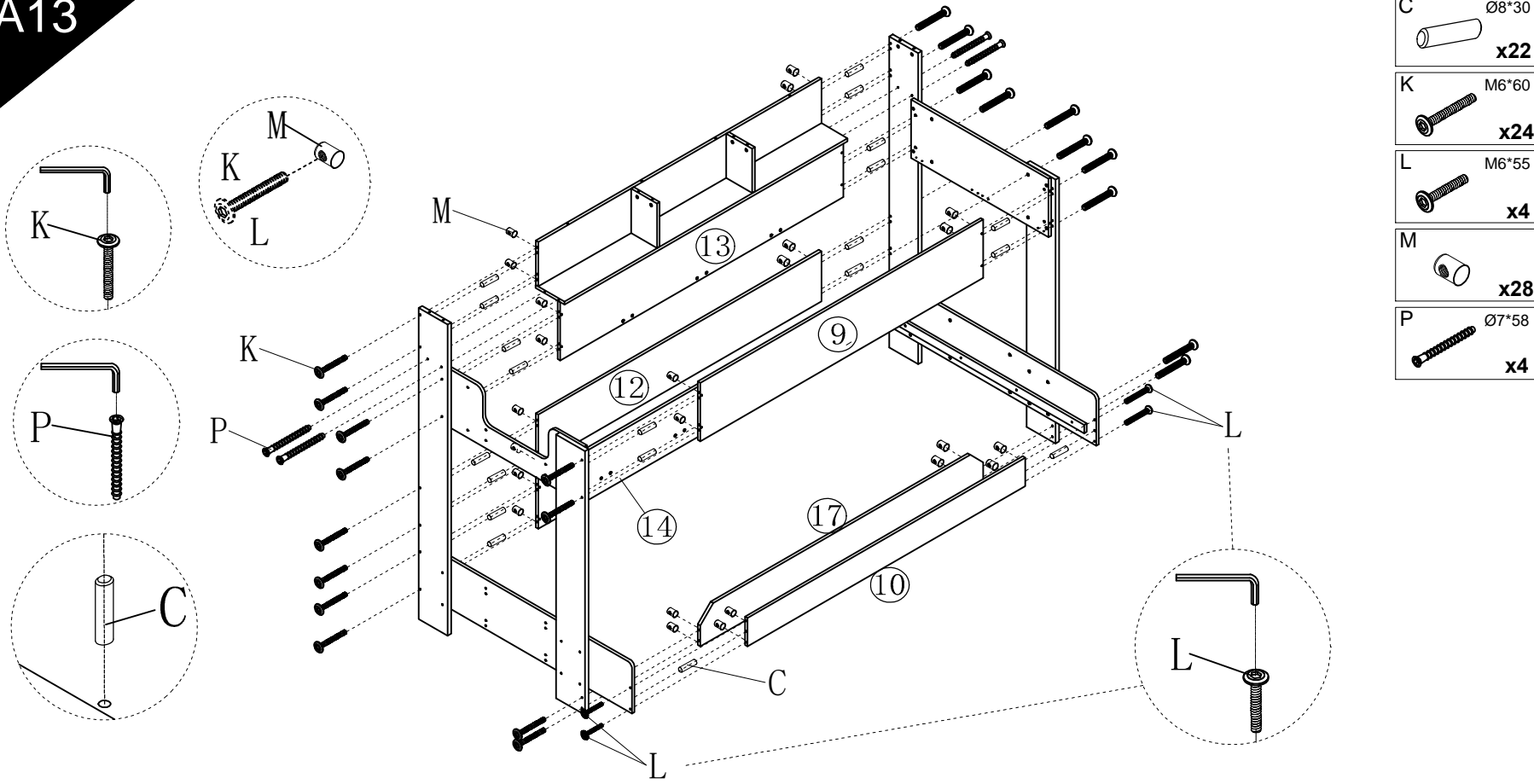

- C  $\varnothing 8 \times 30$   
x22
- K M6\*60  
x24
- L M6\*55  
x4
- M  $\varnothing 7 \times 58$   
x28
- P  $\varnothing 7 \times 58$   
x4

# A14

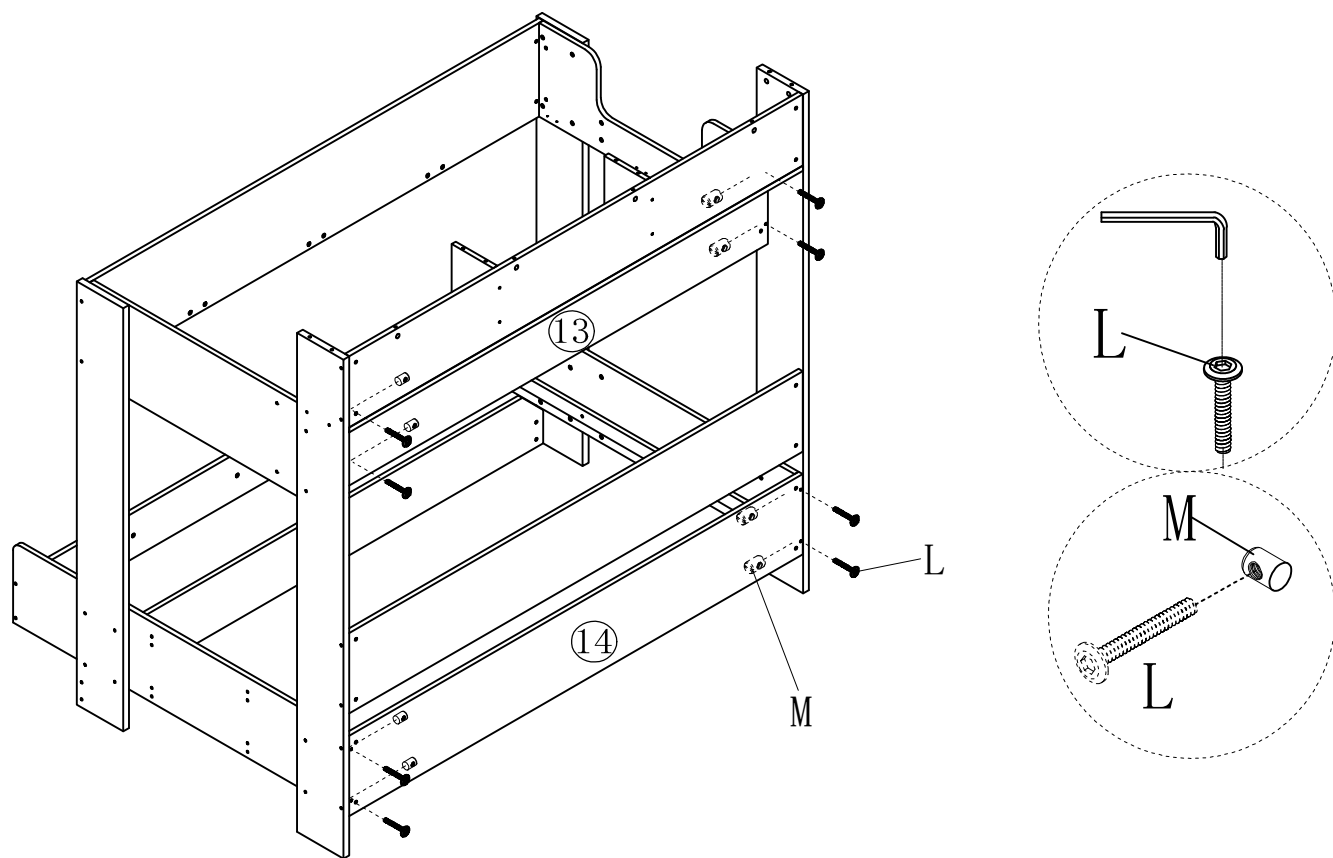

- L M6\*55  
x8
- M  $\varnothing 7 \times 58$   
x8

# A15

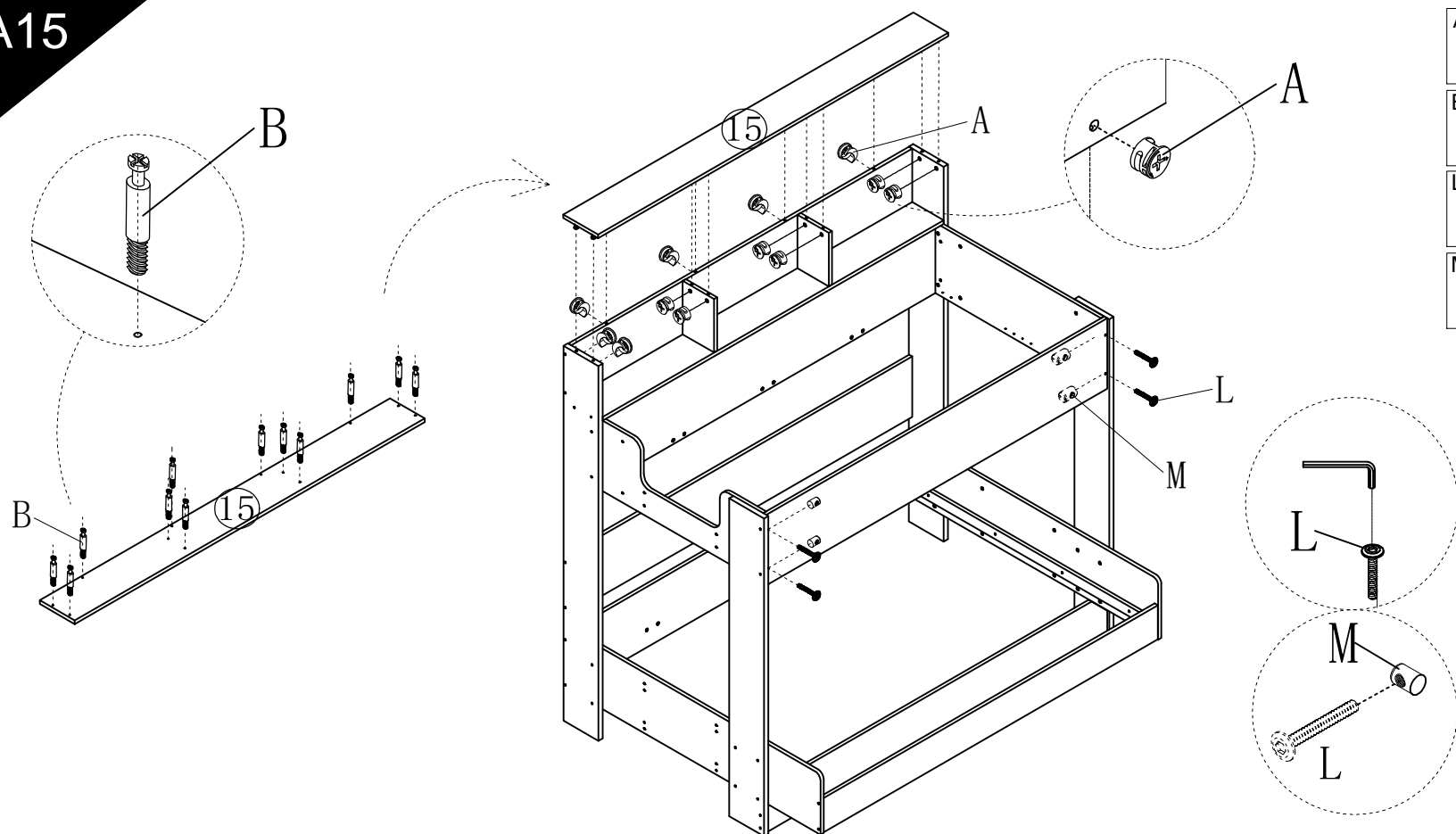

- A  $\varnothing 15 \times 12$   
x12
- B  $\varnothing 7.8 \times 35$   
x12
- L M6\*55  
x4
- M  $\varnothing 7 \times 58$   
x4

A16

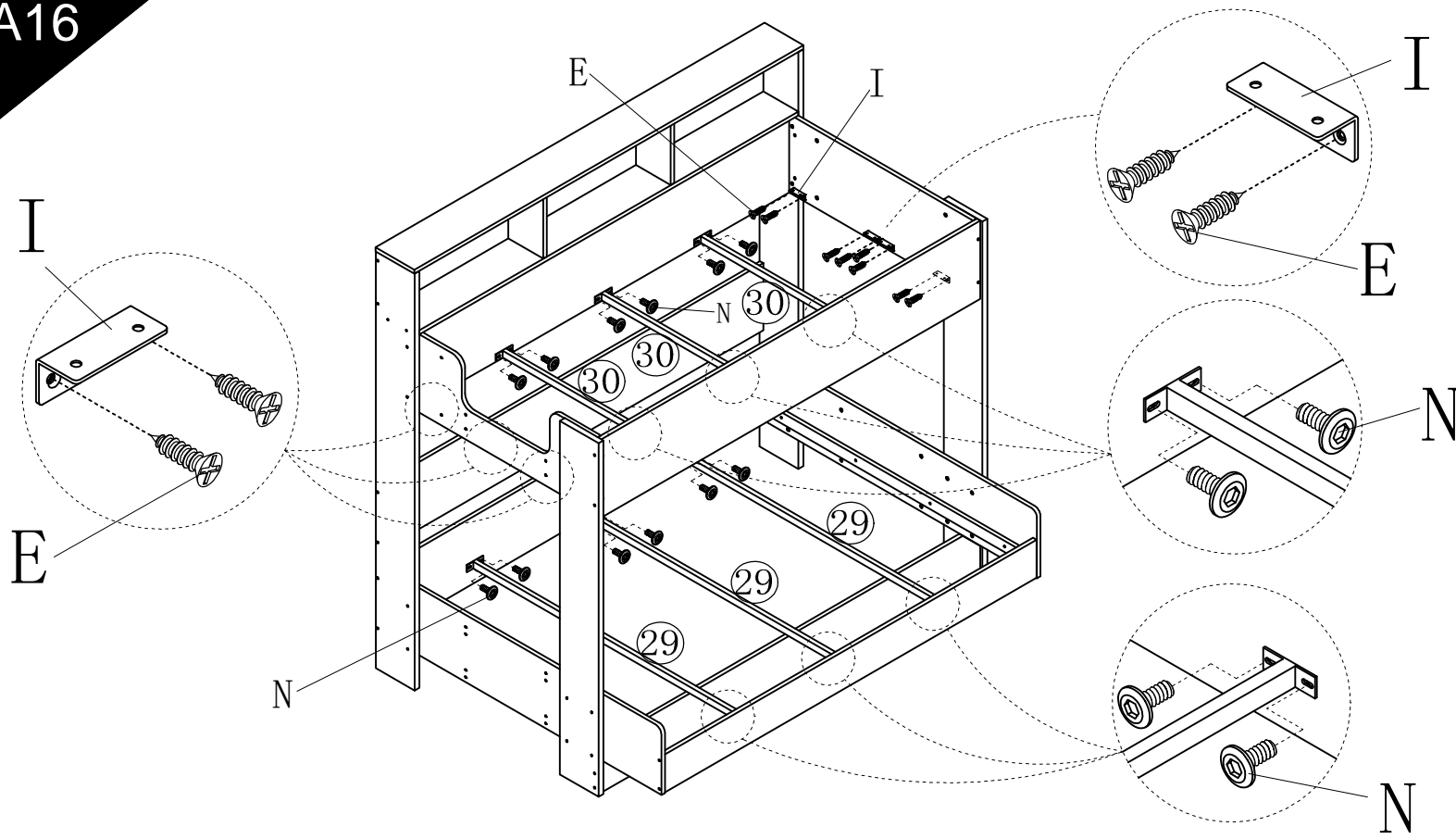

- E  $\varnothing 4 \times 16$   
x16
- N M6  $\times 15$   
x24
- I 60  $\times 25 \times 25$   
x8

A17

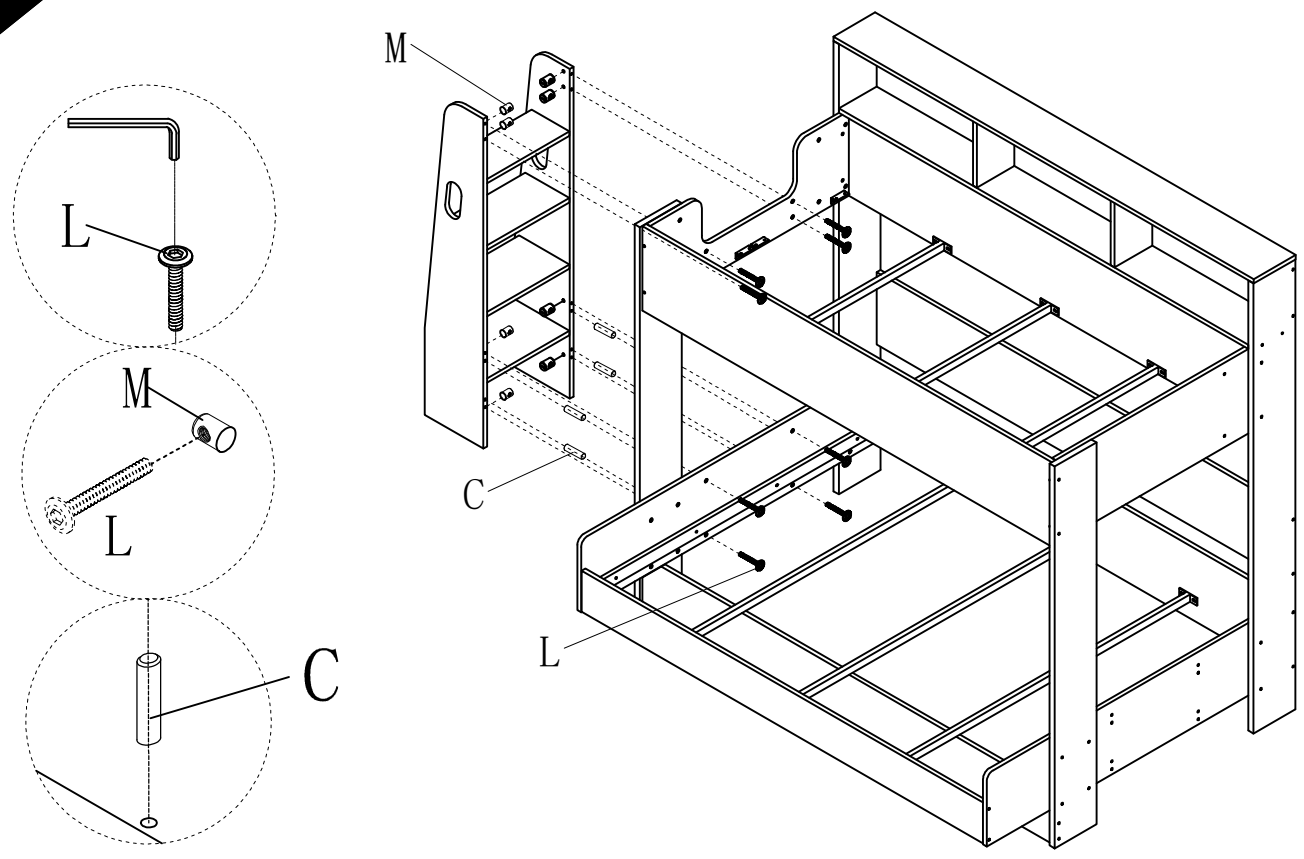

- C  $\varnothing 8 \times 30$   
x4
- L M6  $\times 55$   
x8
- M  $\varnothing 6$   
x8

A18

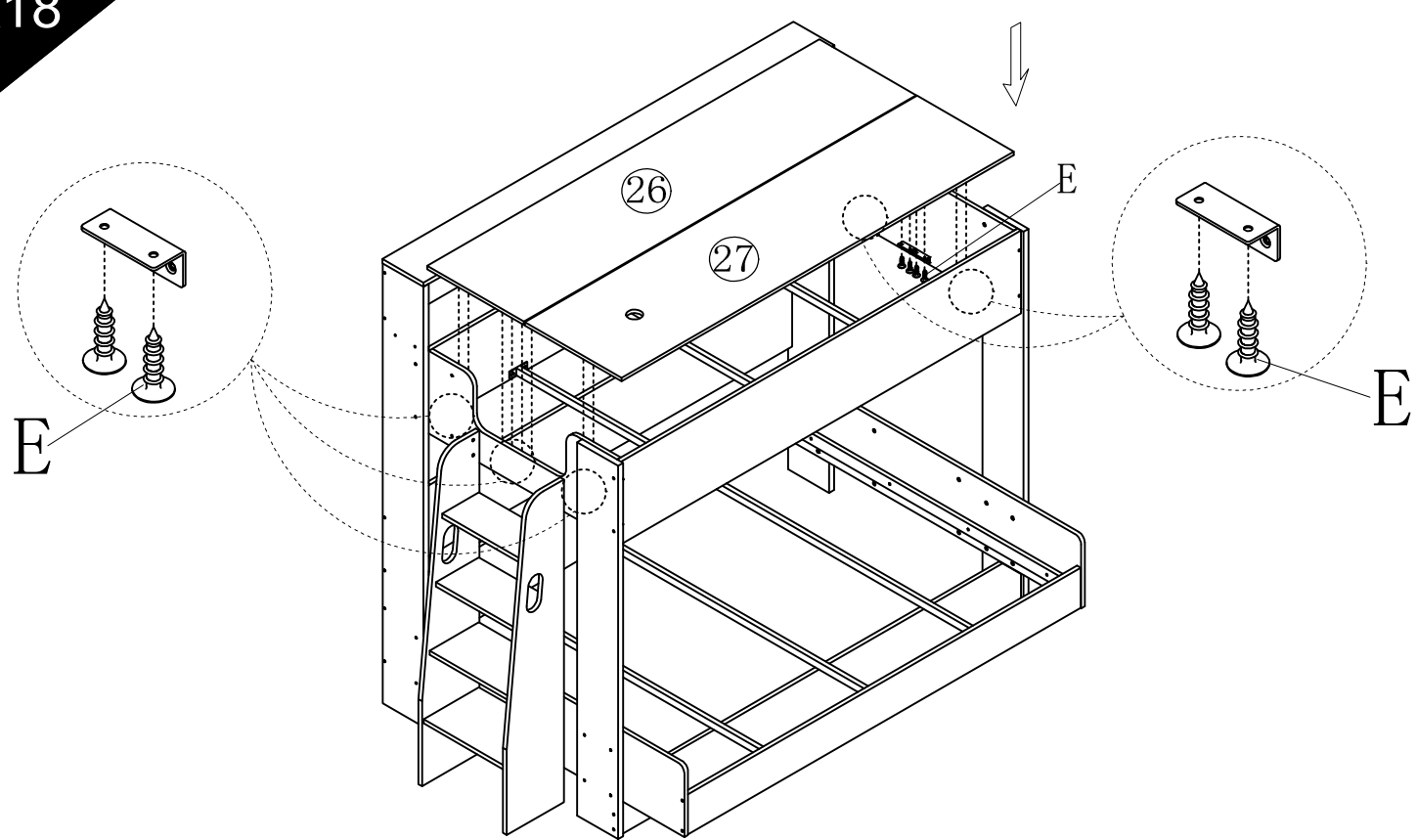

- E  $\varnothing 4 \times 16$   
x16

A19

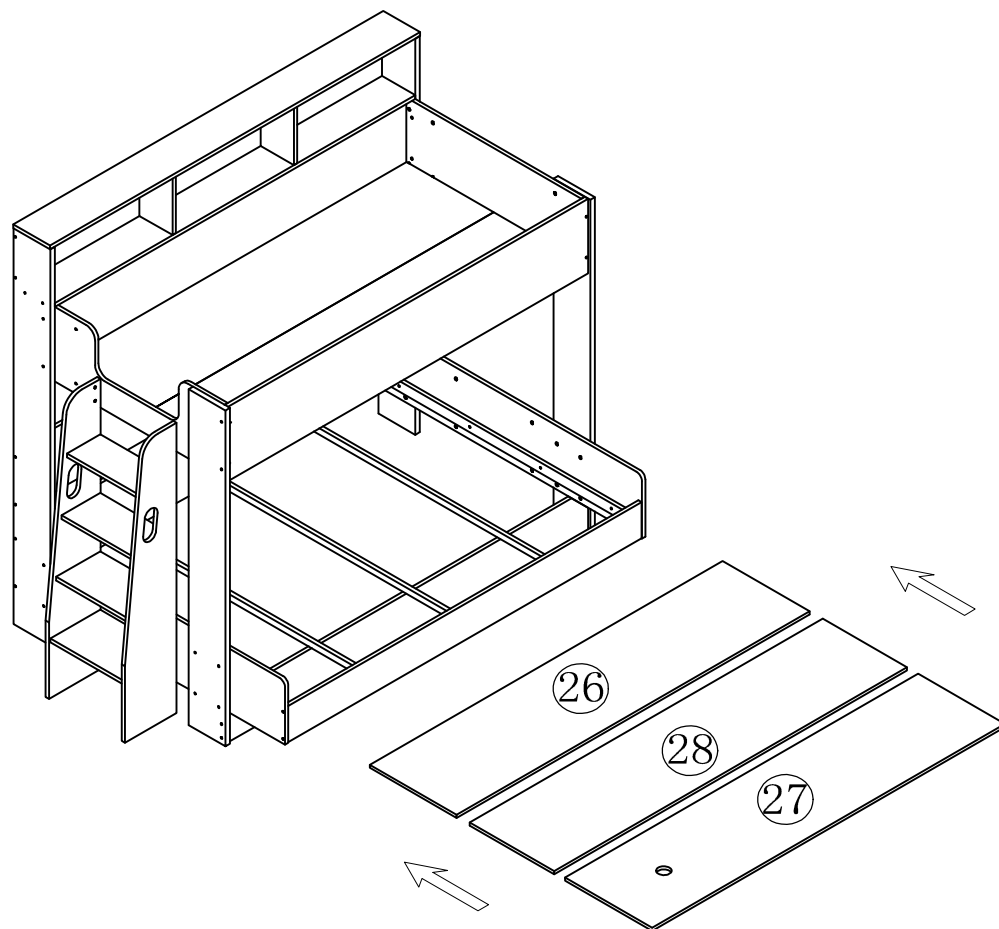

A20

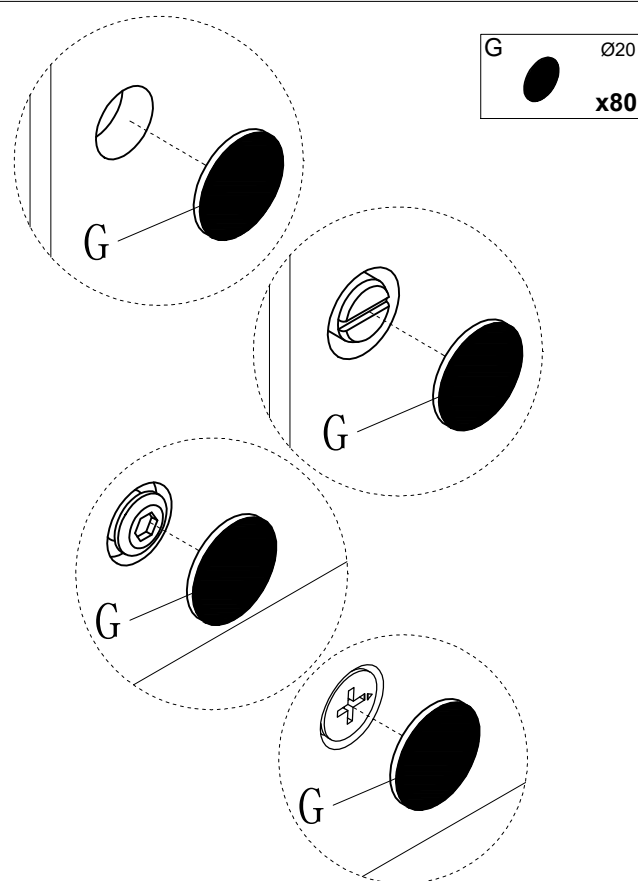
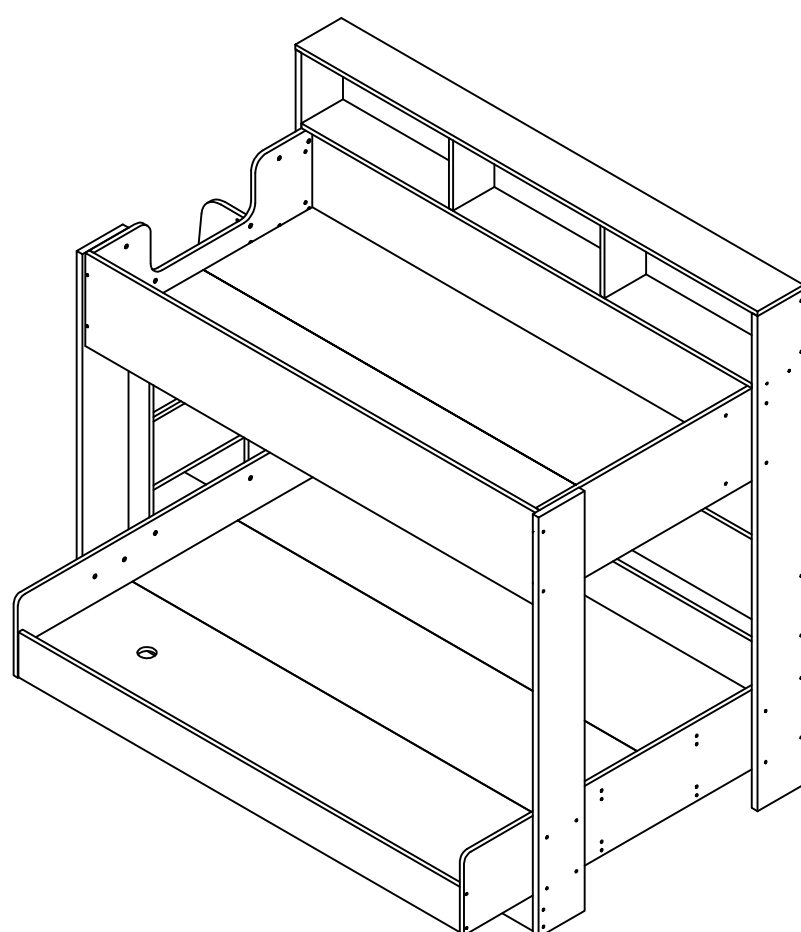

A21

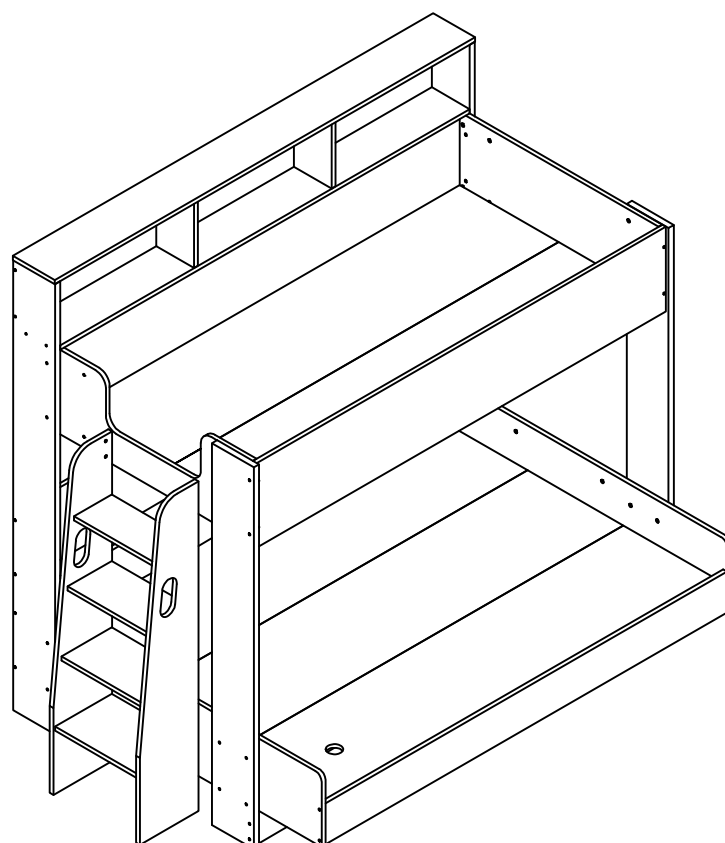

B1

- B  $\varnothing 7.8 \times 35$   
x16
- D  $\varnothing 18 \times 4$   
x4

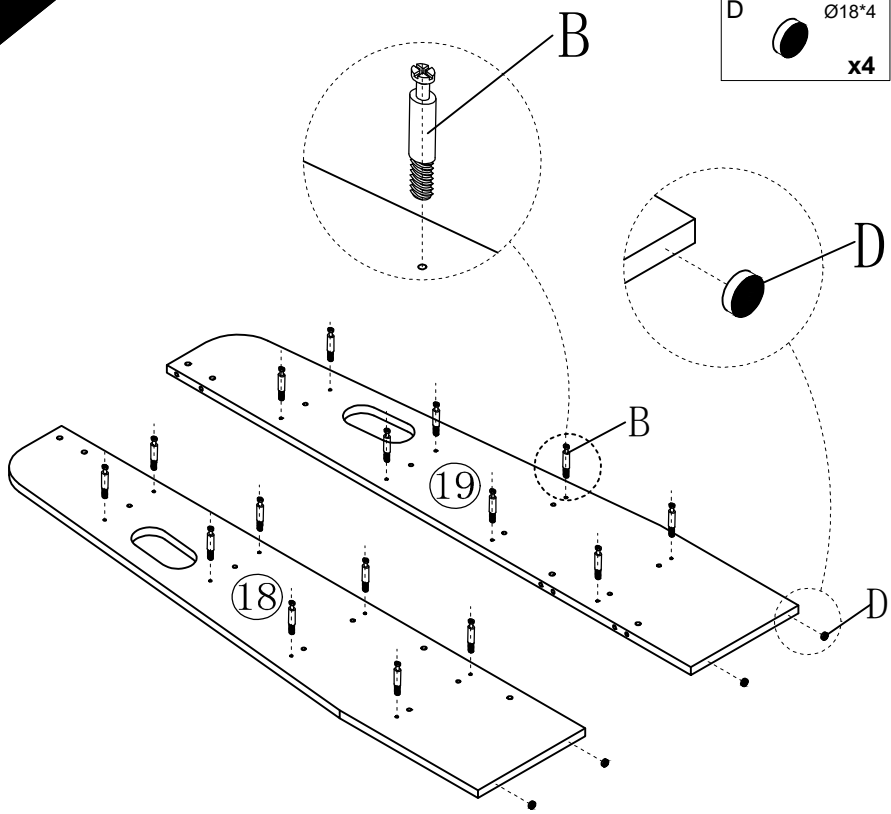

B2

- E  $\varnothing 4 \times 16$   
x16
- F  $20 \times 20 \times 2$   
x16

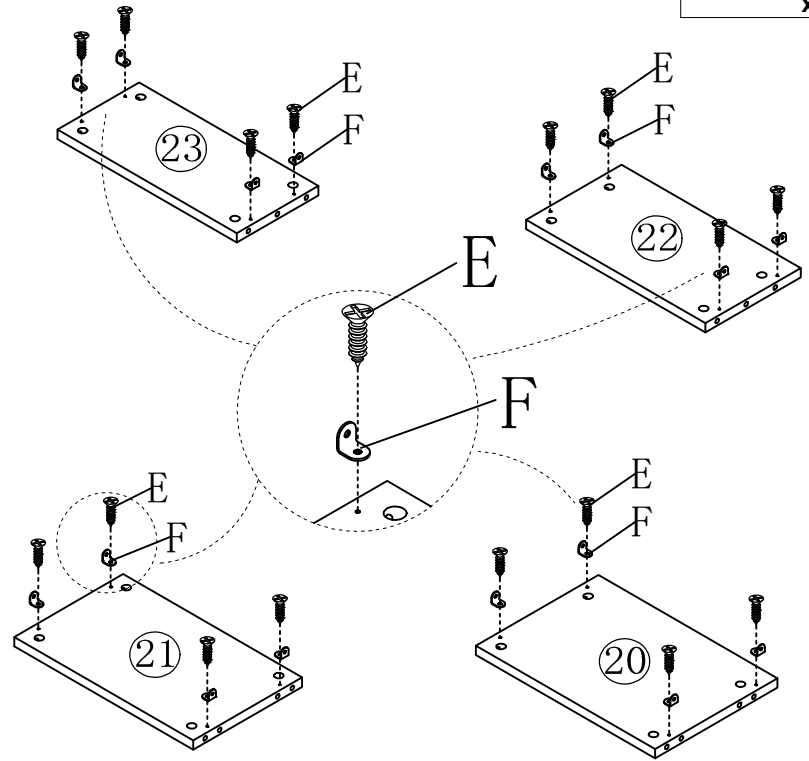

B3

- A  $\varnothing 15 \times 12$   
x8
- C  $\varnothing 8 \times 30$   
x6

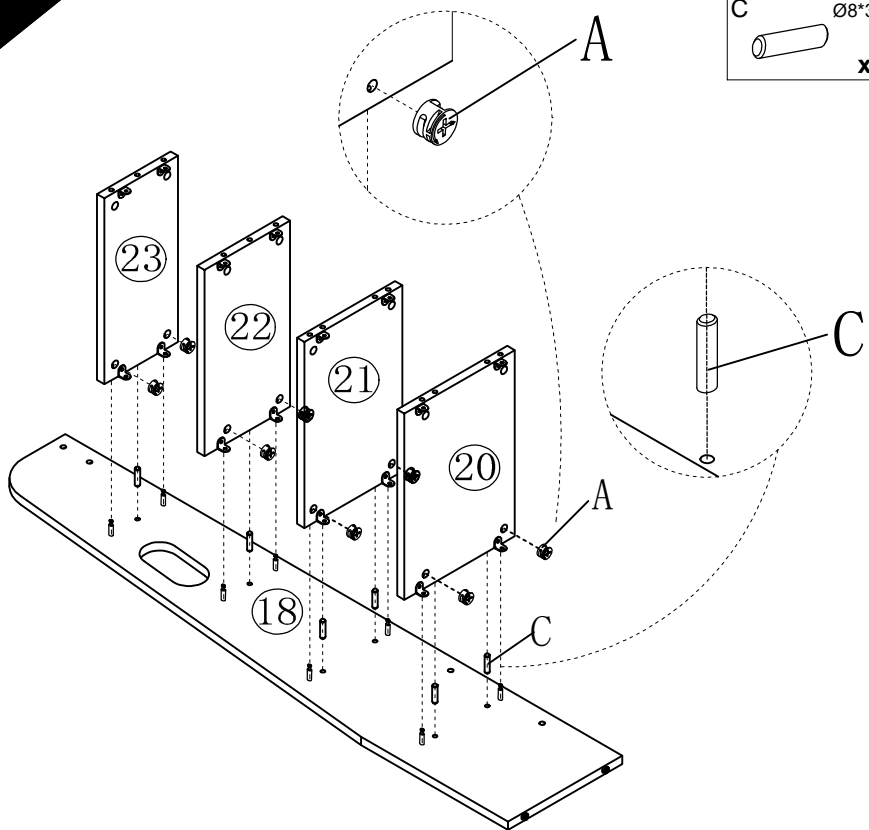

B4

- A  $\varnothing 15 \times 12$   
x8
- C  $\varnothing 8 \times 30$   
x6

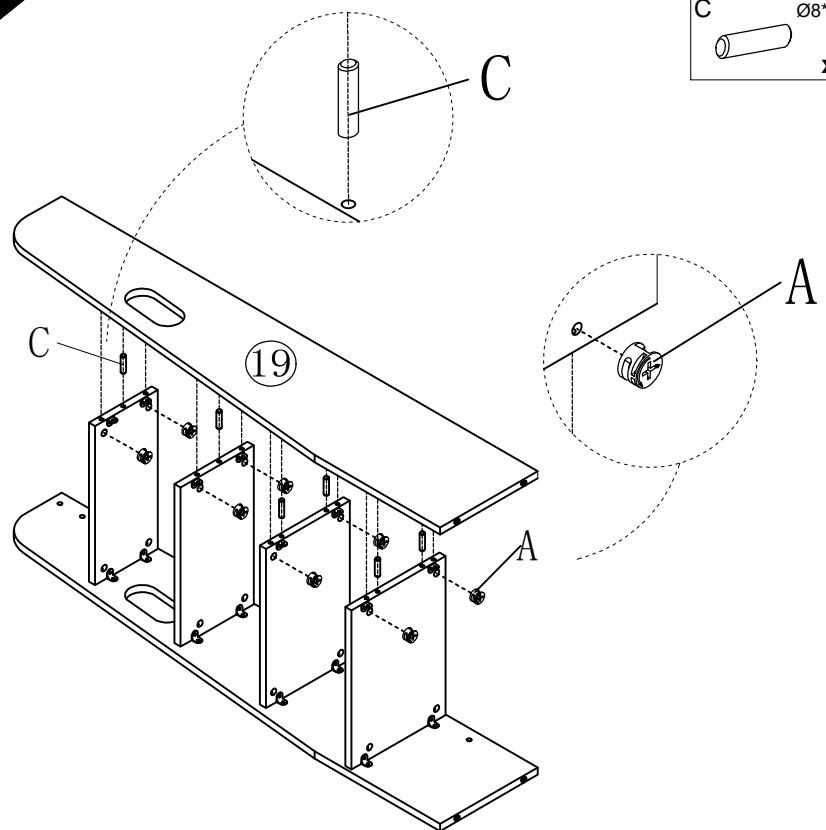

B5

- E  $\varnothing 4 \times 16$   
x16

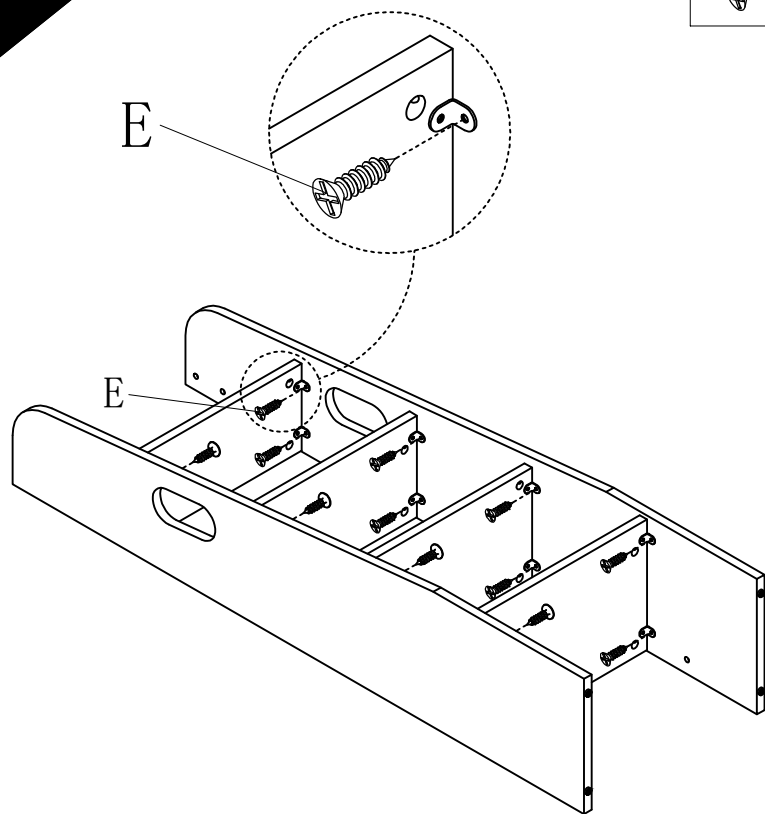

B6

- D  $\varnothing 18 \times 4$   
x4
- H 4MM  
x1
- J M6x30  
x12
- Q M6x18  
x6

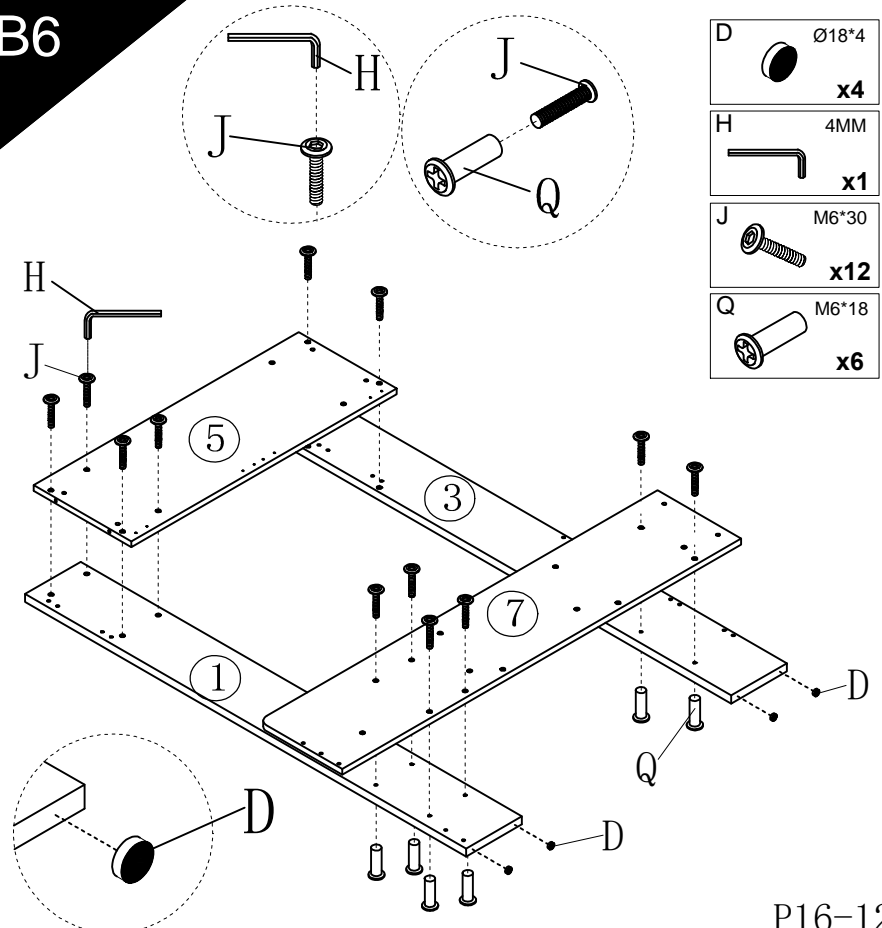

B7

J M6\*30 x4

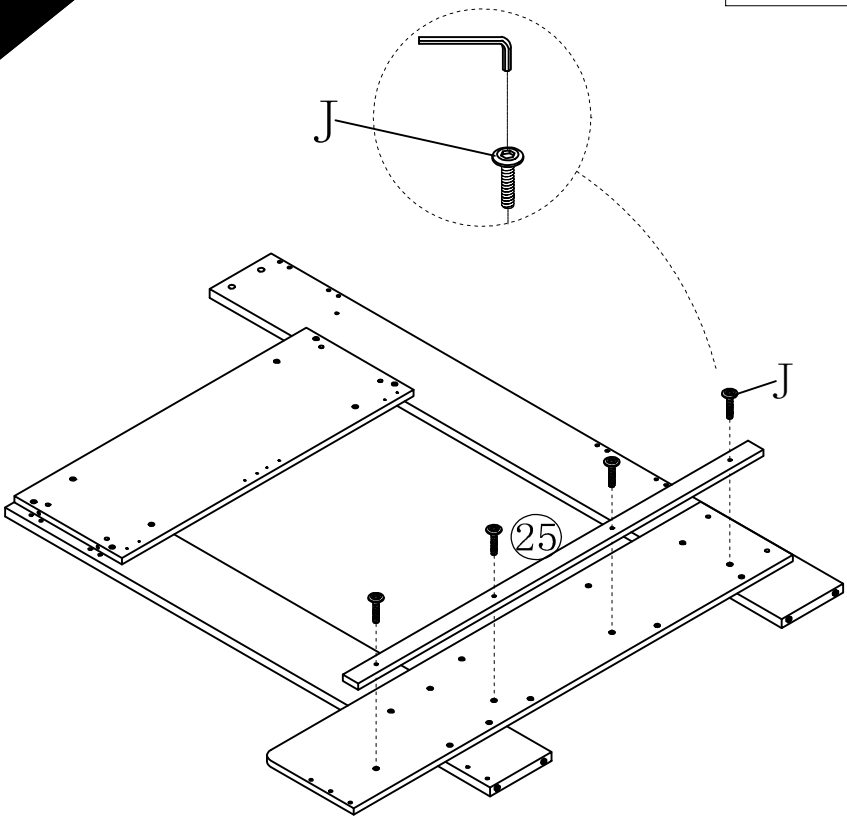

B8

D Ø18\*4 x4  
 J M6\*30 x12  
 Q M6\*18 x6

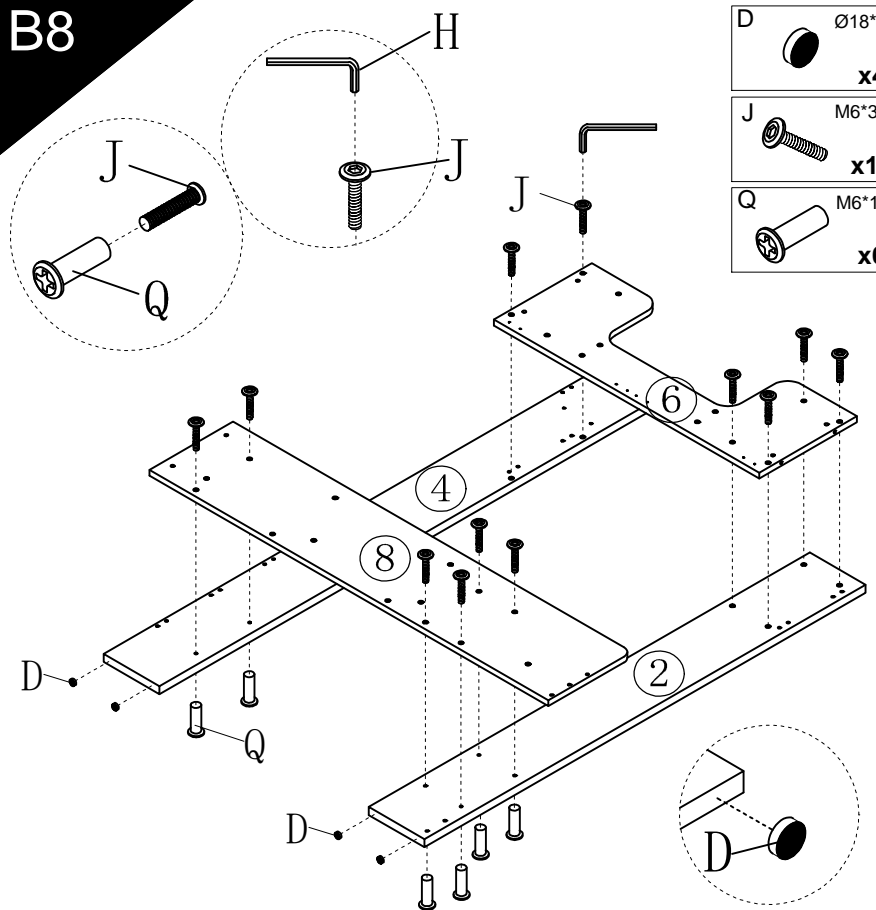

B9

J M6\*30 x4

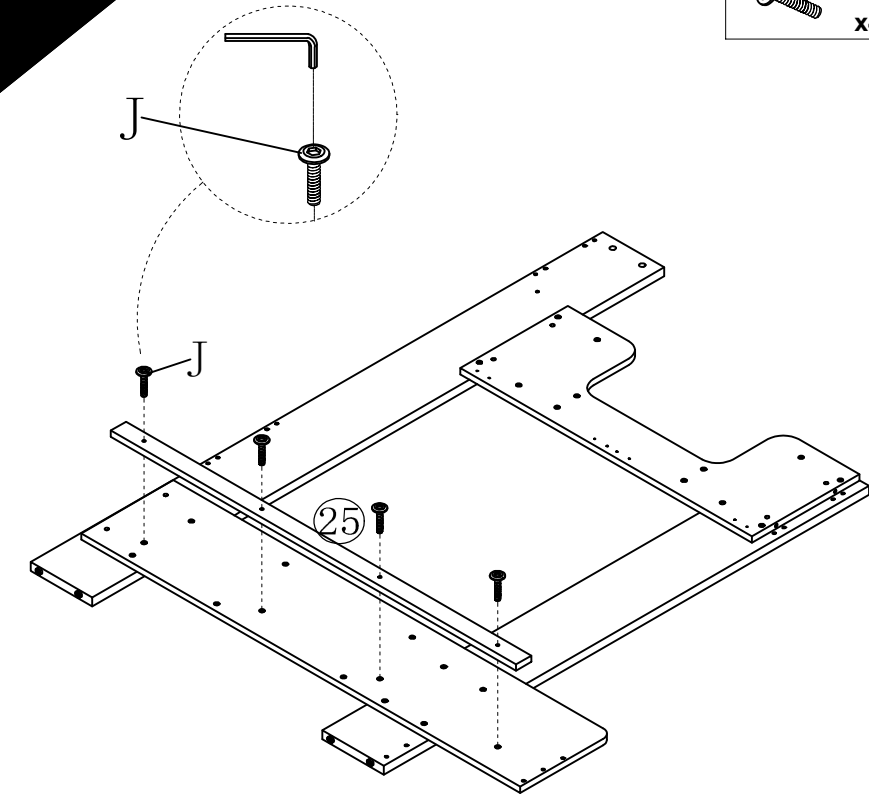

B10

B Ø7.8\*35 x4  
 O Ø7\*48 x4

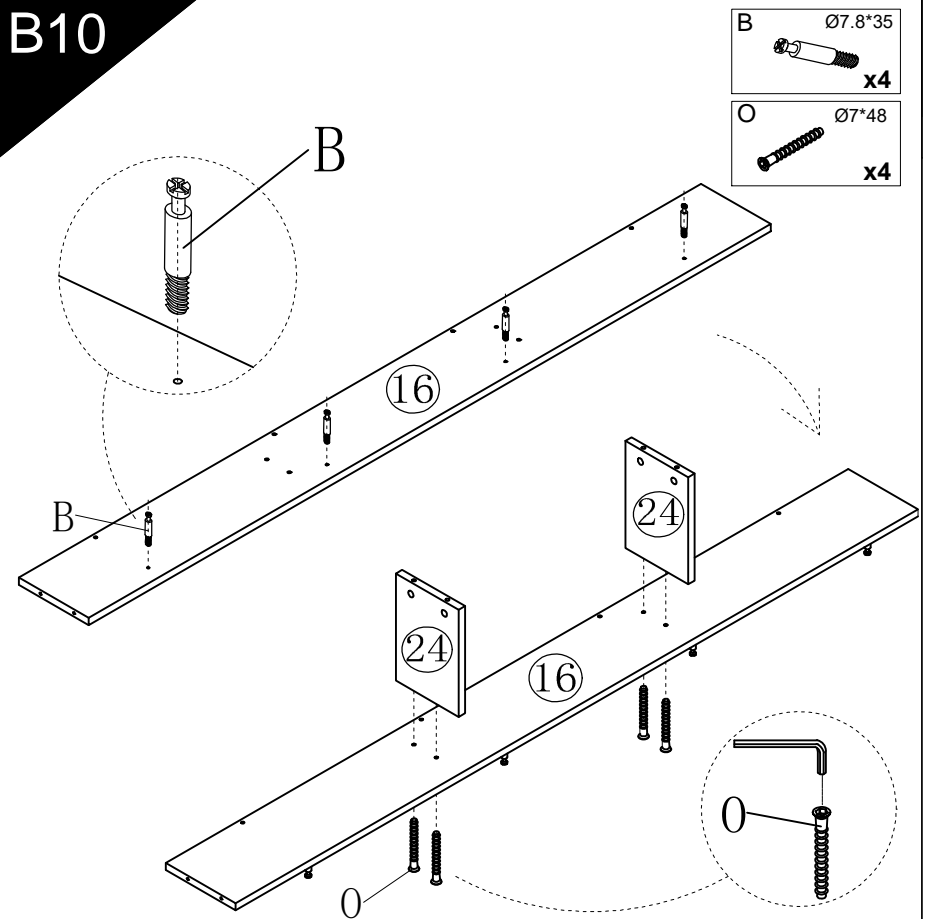

B11

O Ø7\*48 x8

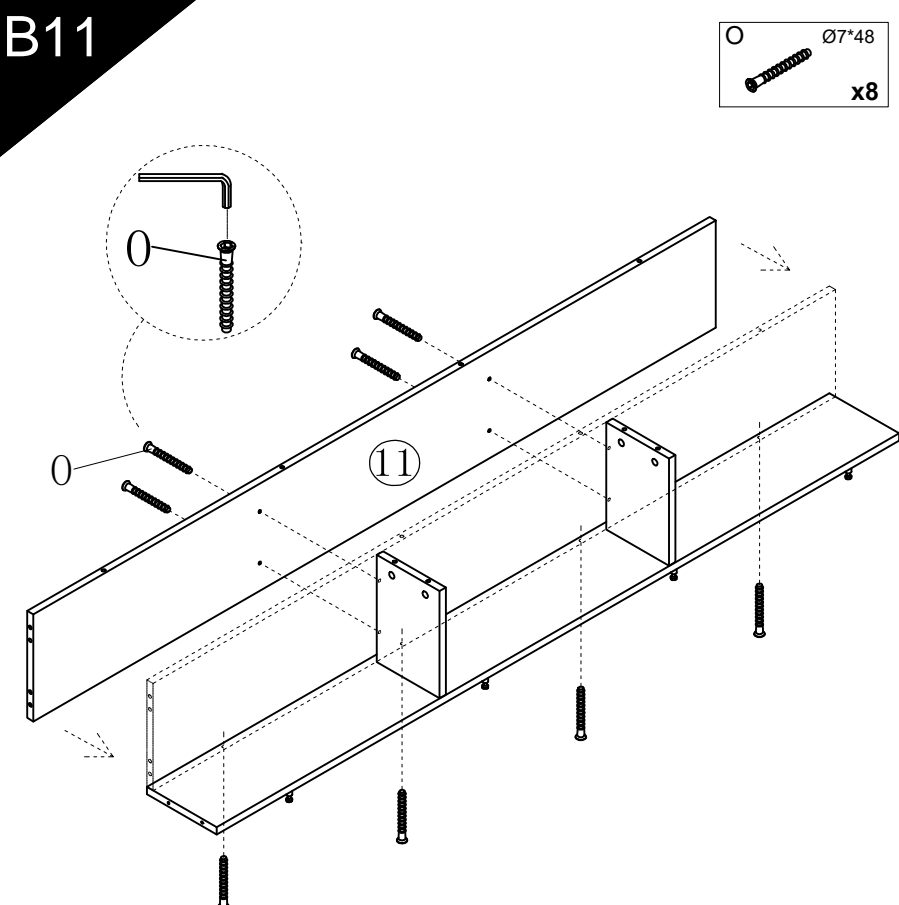

B12

A Ø15\*12 x4

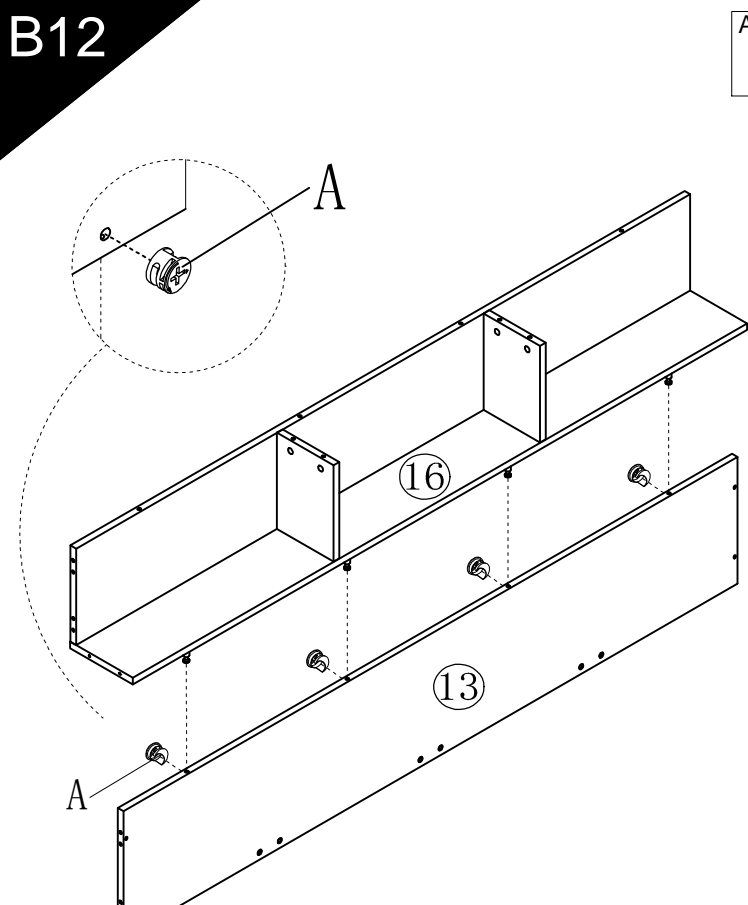

**B13**

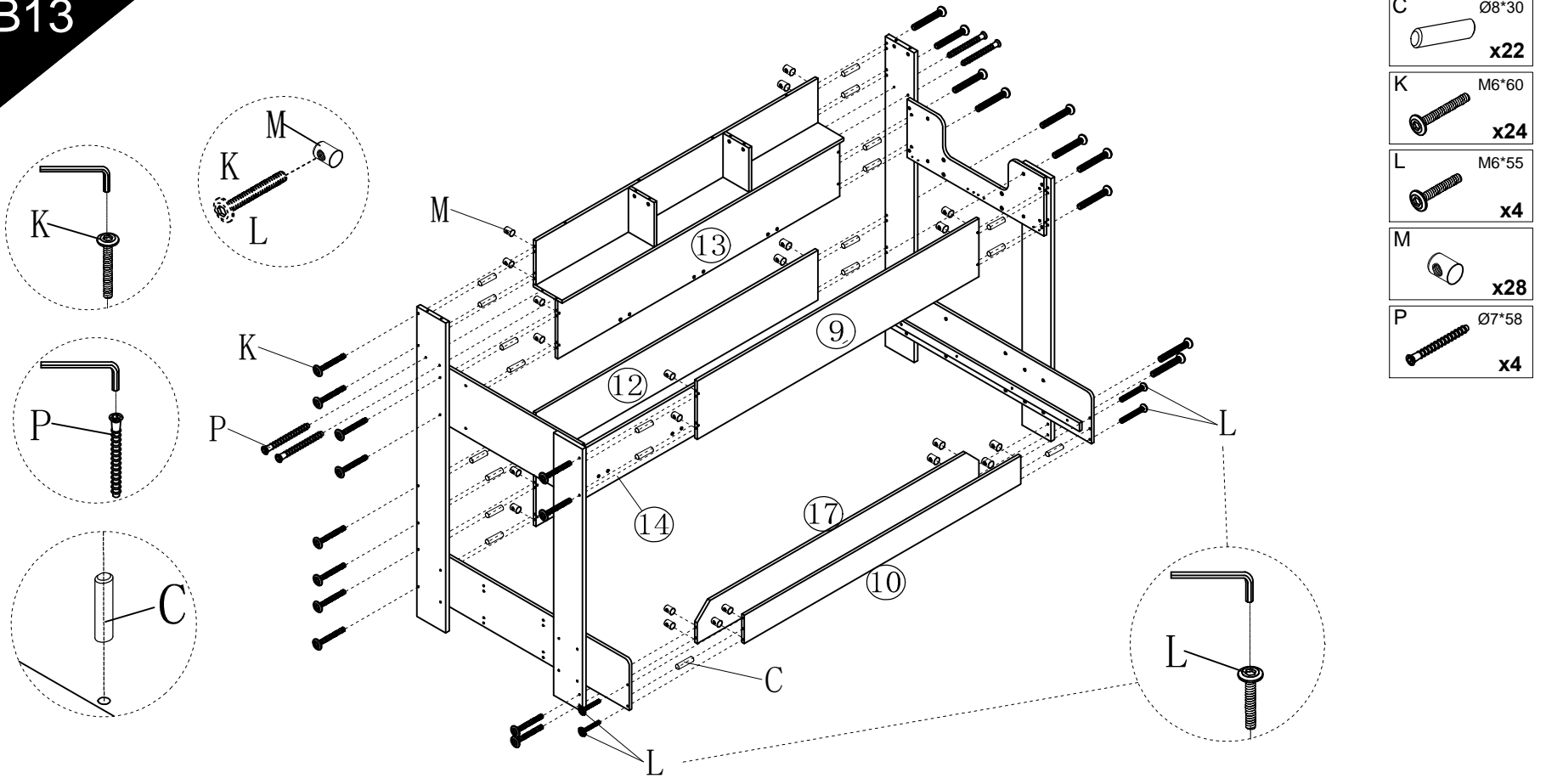

**B14**

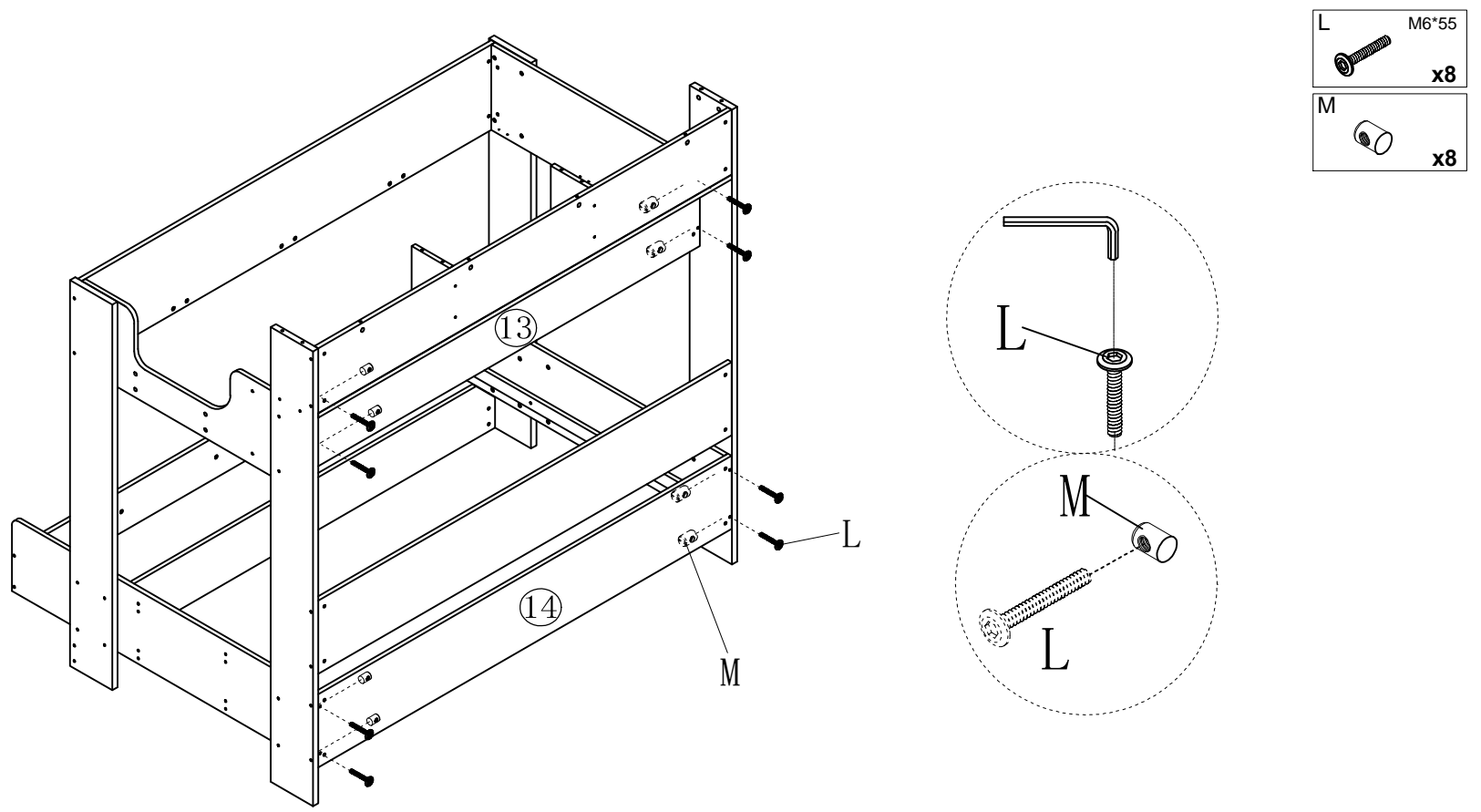

**B15**

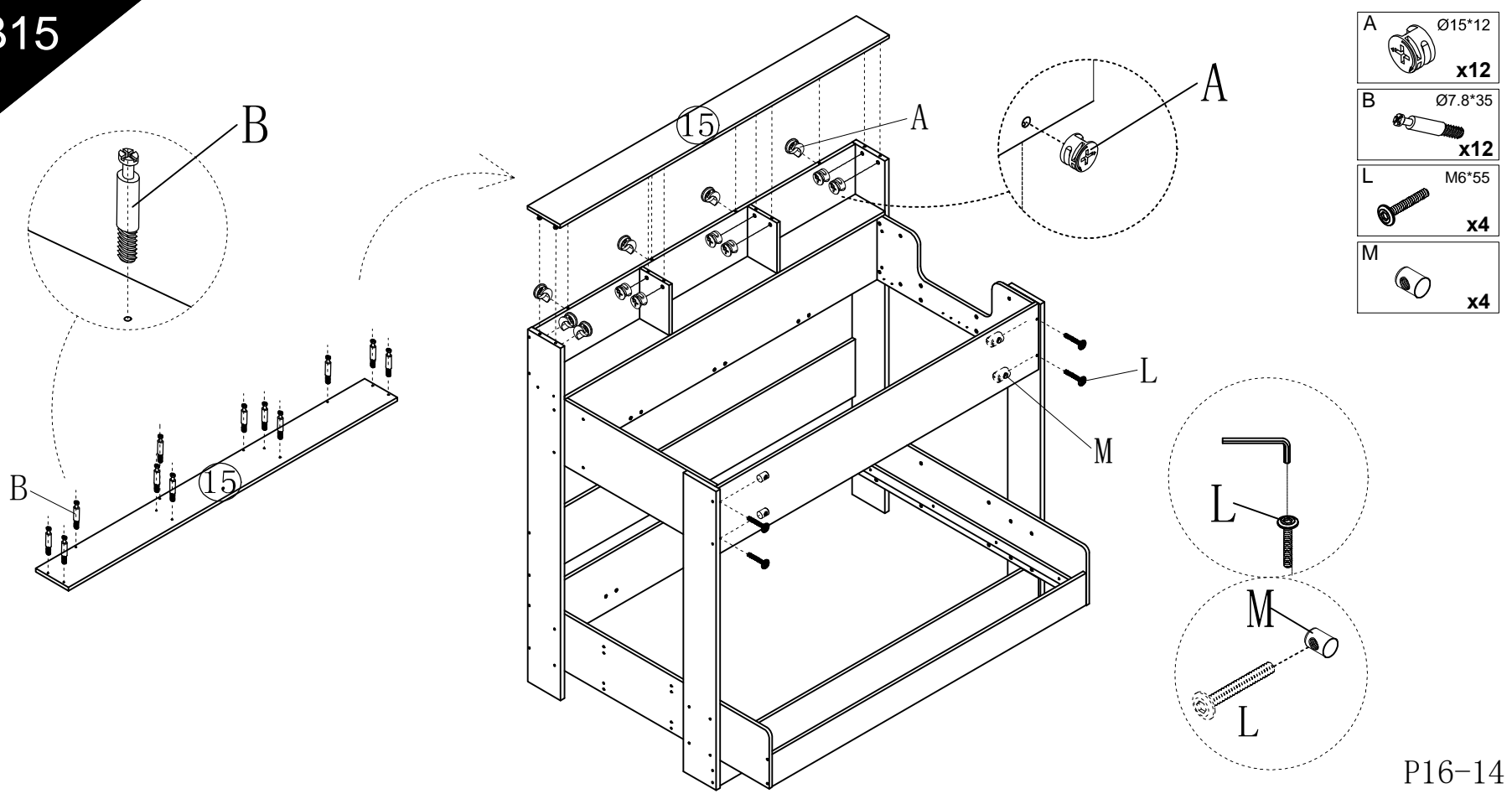

**B16**

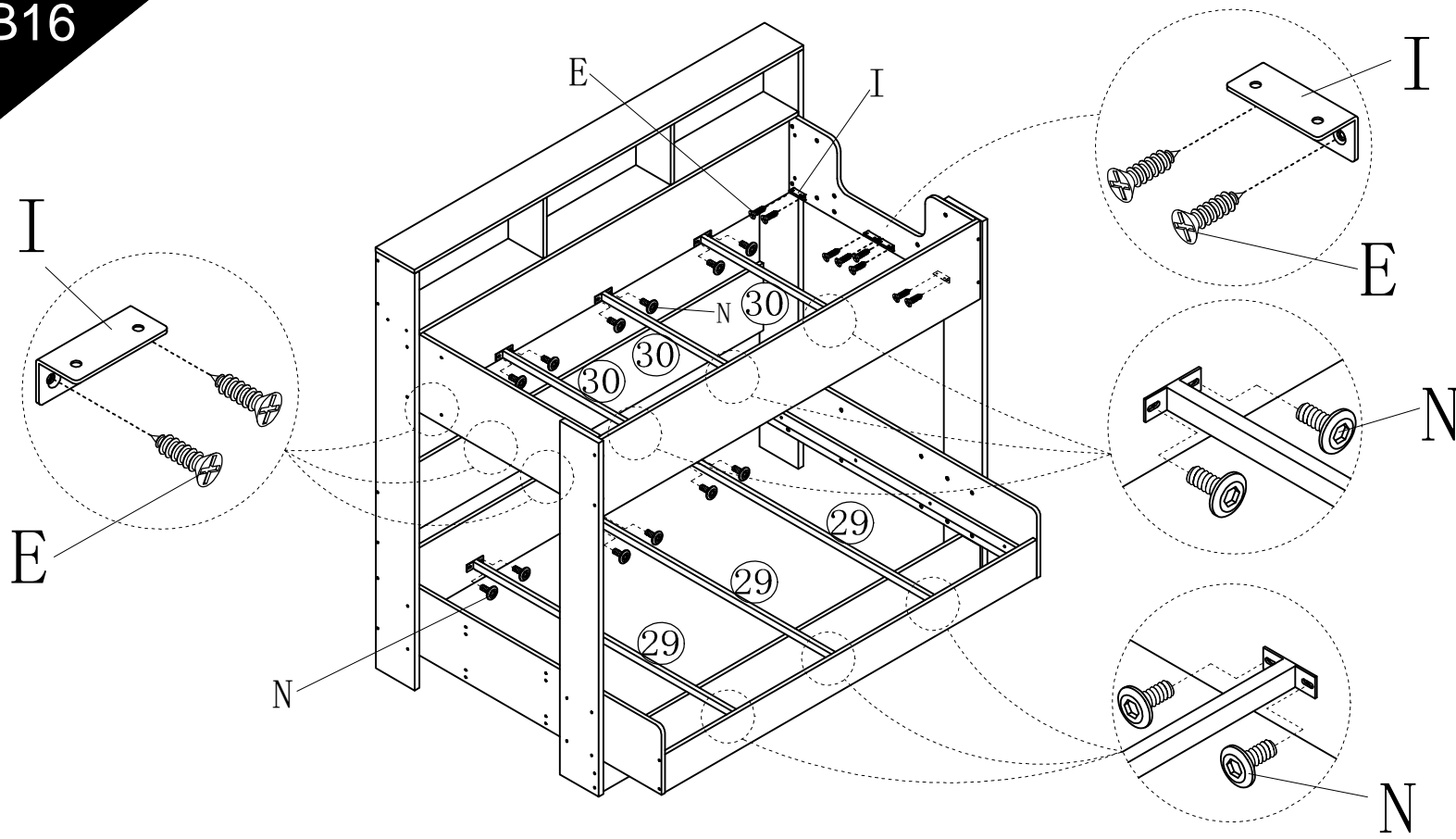

- E  $\varnothing 4 \times 16$   
x16
- N M6  $\times 15$   
x24
- I 60  $\times 25 \times 25$   
x8

**B17**

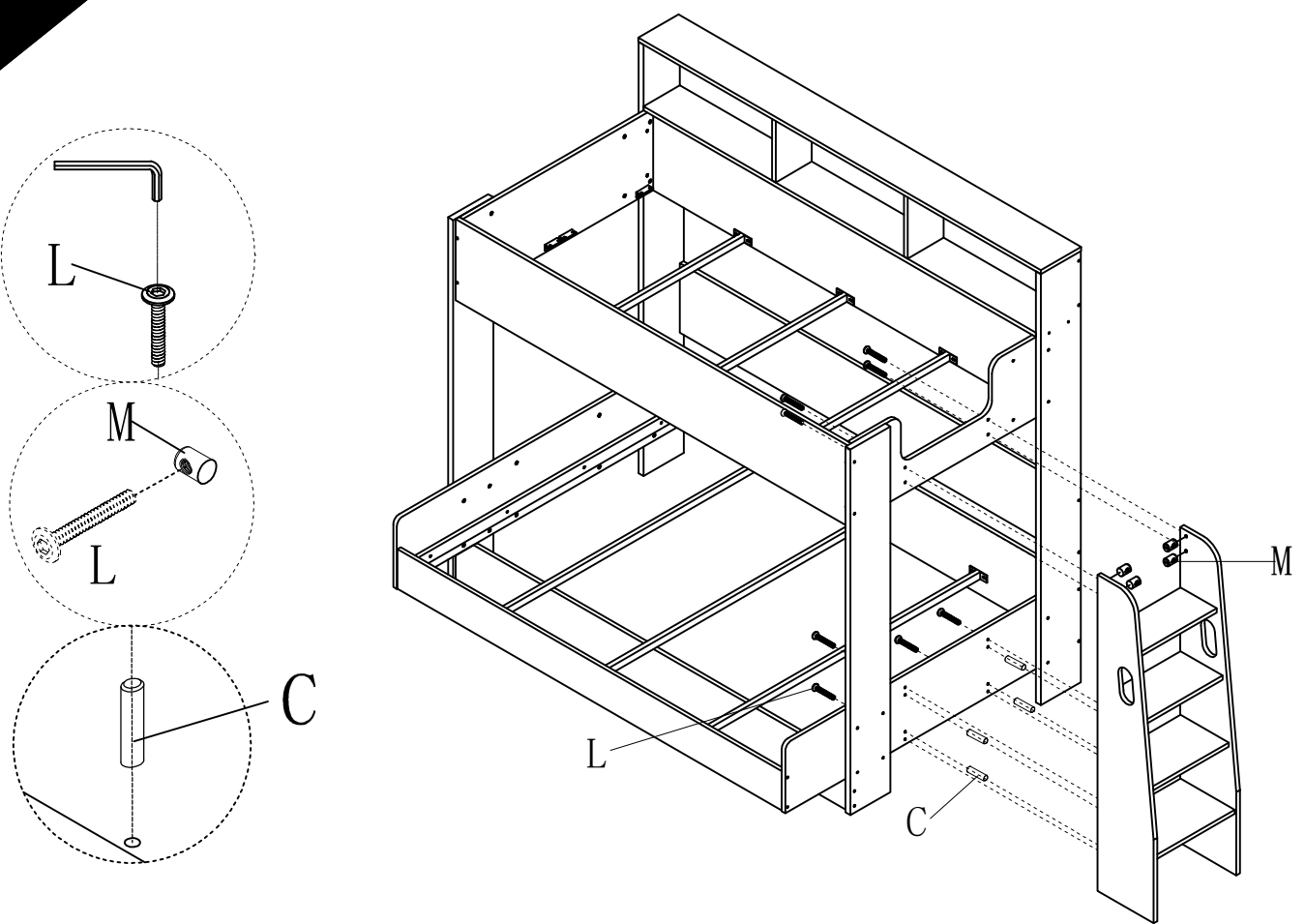

- C  $\varnothing 8 \times 30$   
x4
- L M6  $\times 55$   
x8
- M   
x8

**B18**

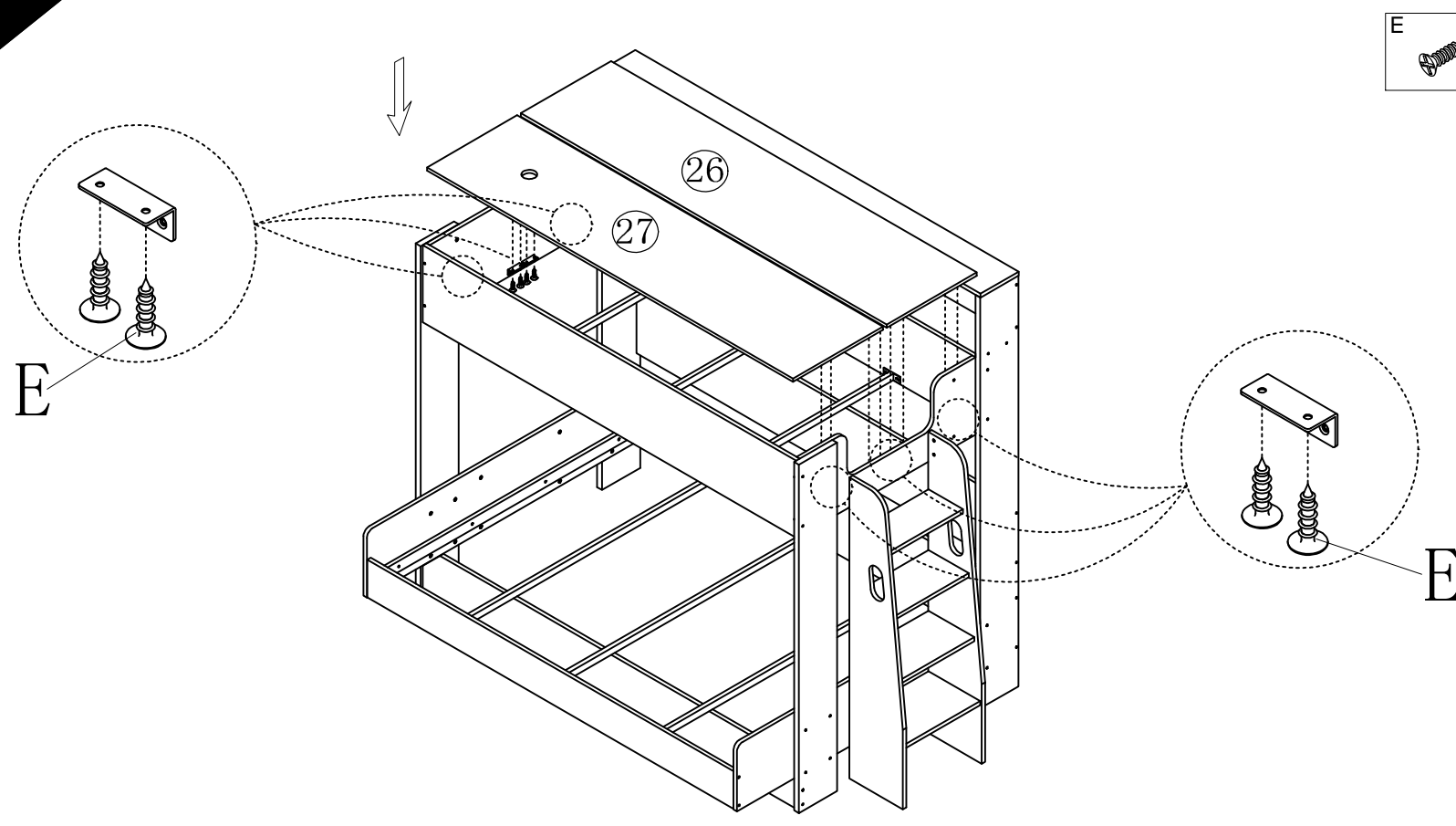

- E  $\varnothing 4 \times 16$   
x16

B19

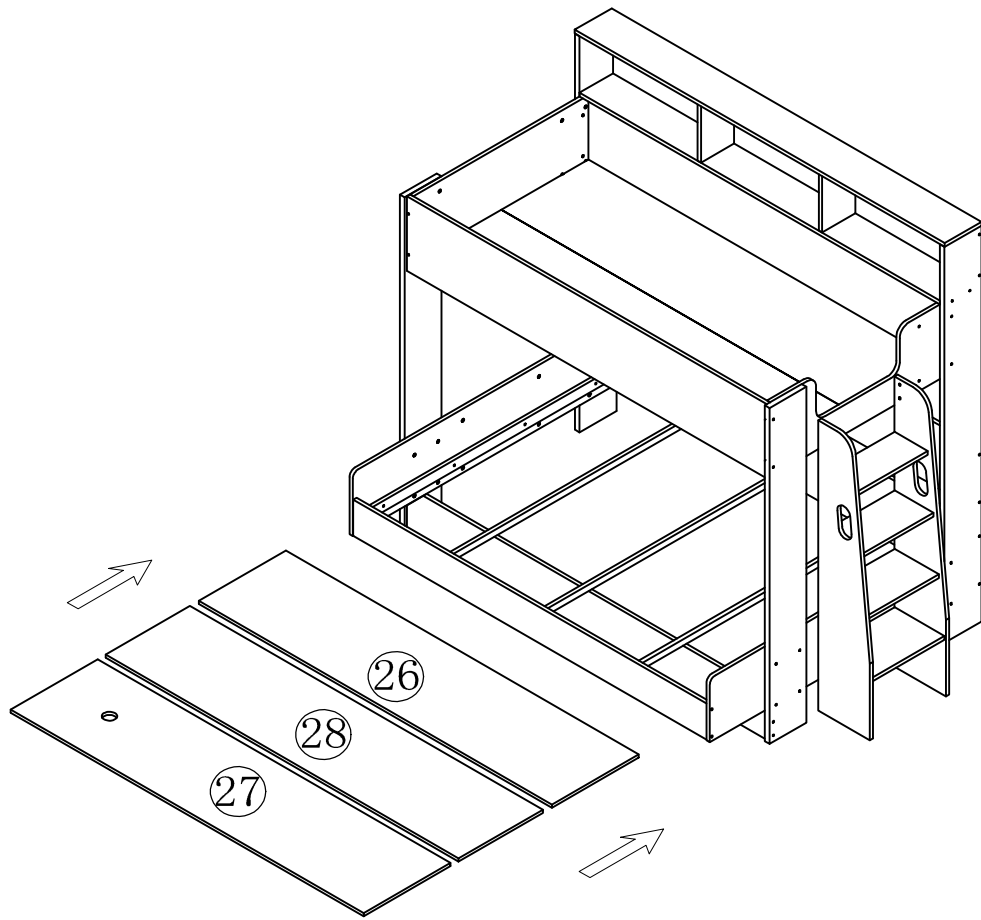

B20

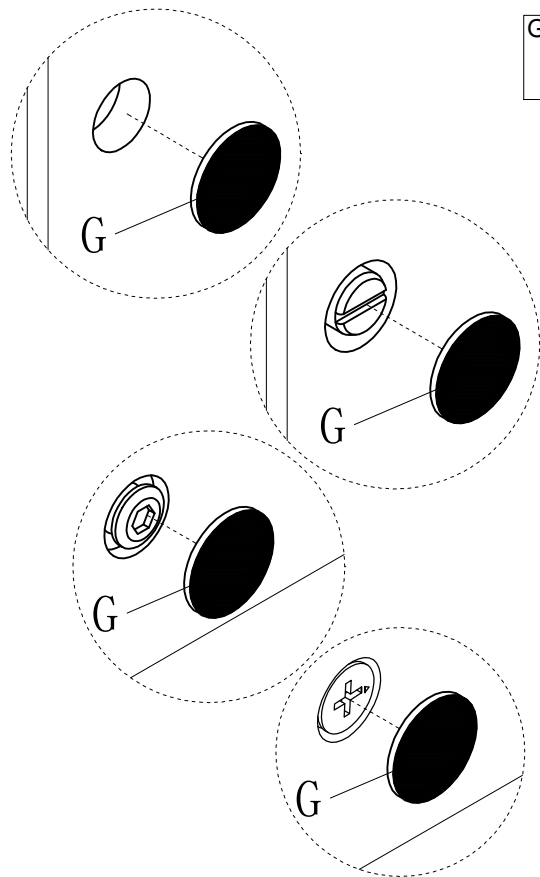
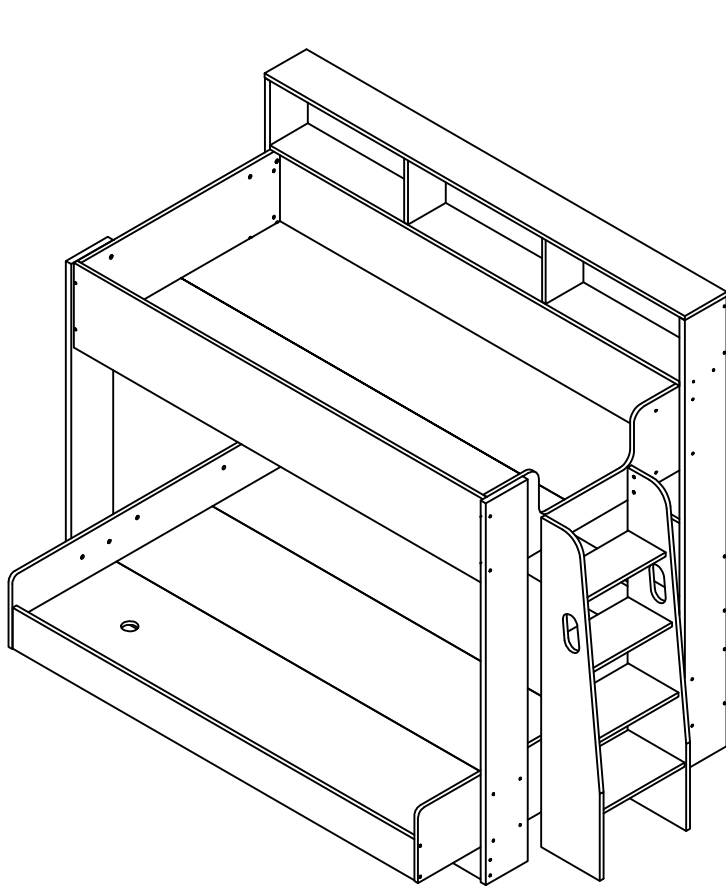

G Ø20  
x80

B21

