

ISTRUZIONI DI MONTAGGIO DEL VOLANTE

STEERING WHEEL FITTING INSTRUCTIONS

INSTRUCTIONS DE MONTAGE DU VOLANT

LENKRAD-MONTAGEANLEITUNG



La scatola contiene
The box includes
La boîte comprend
Lieferumfang
La caja incluye

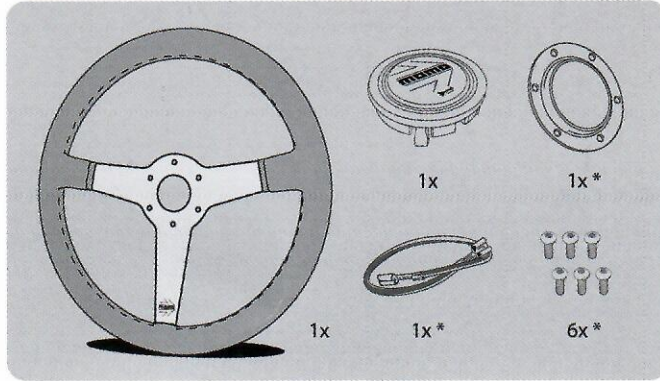

Mozzo MOMO acquistabile separatamente, controllare la disponibilità per la propria vettura.
Momo hub sold separately, check the availability for your vehicle.
Moyeu MOMO vendu séparément, vérifiez la disponibilité pour votre véhicule.
Momo Lenkradnabe separat erhältlich. Bitte prüfen Sie, ob es eine passende Nabe für Ihr Fahrzeug gibt.
MOMO buje volante se vende por separado, compruebe la disponibilidad para su vehículo.

Ordine di assemblaggio delle parti
Assembly sequence
Ordre de montage
Montage-Reihenfolge
Secuencia de montaje

Presente SOLO in alcuni modelli
Parts only available for some models
Pièce disponible sur certains modèles
Der Ring ist nur bei einigen Lenkradmodellen vorhanden
Partes sólo disponibles para algunos modelos.

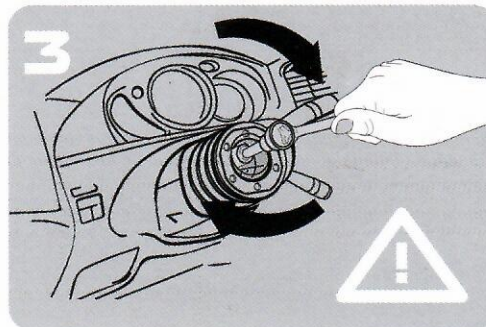
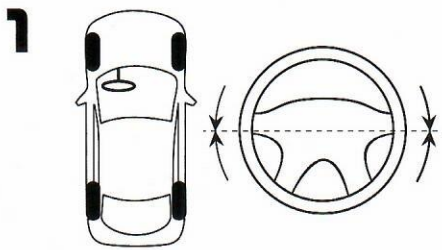
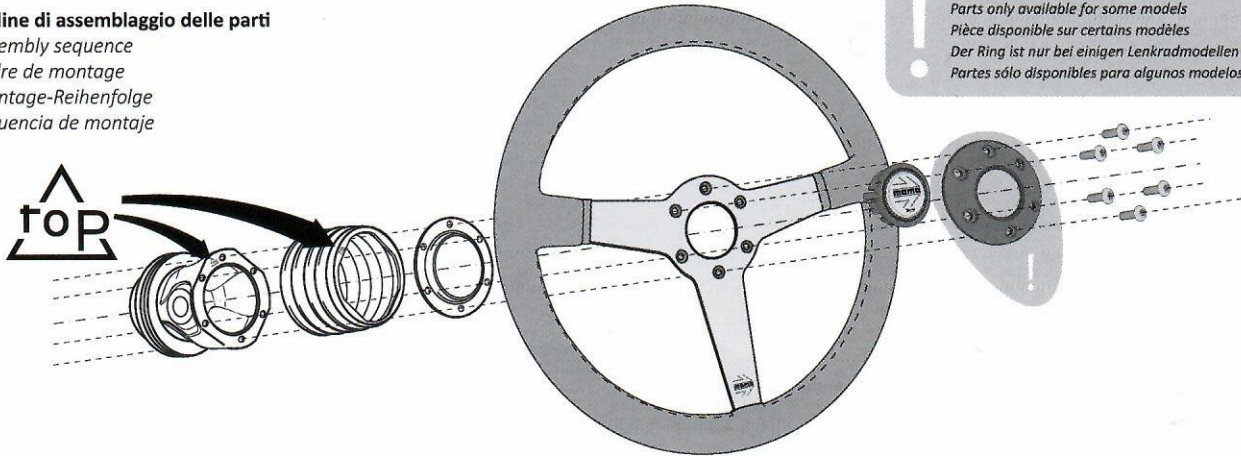

Seguire le istruzioni di montaggio relative al mozzo acquistato e prestare particolare attenzione al valore di serraggio indicato (Nm).

Please read the Momo hub installation fitting instructions and find out the correct fastening torque.

Veillez s'il vous plait lire les instructions de montage du moyeu afin de connaître le couple de serrage (Nm).

Das korrekte Anzugsmoment (Nm) ist der in der Nabe enthaltenen Einbauanleitung zu entnehmen.

Por favor, lea las instrucciones de instalación buje de Momo para encontrar el par de apriete correcto (Nm).

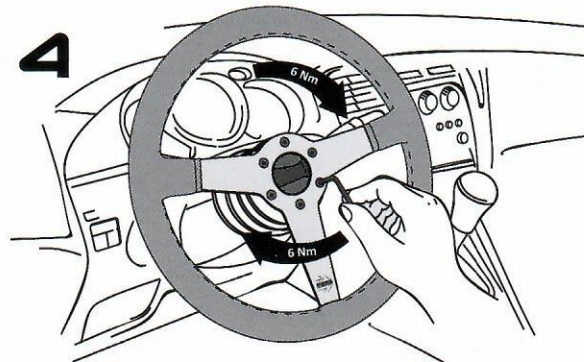
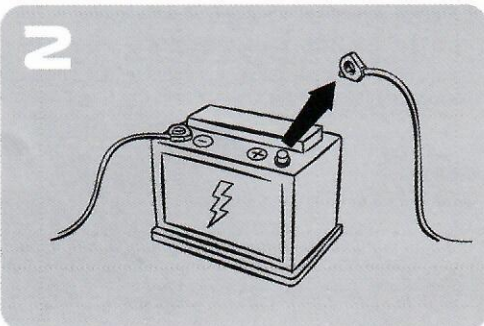

(IT) *Anello fermapulsante, viti e cavo sono inclusi nell'imballo solo se necessari per il modello di volante scelto. In caso contrario utilizzare le parti disponibili nella confezione del mozzo MOMO.
(GB) *Retaining ring, screws and cable are included in the packaging only if needed for the steering wheel model chosen. If not included, please use the components available in the MOMO hub packaging.
(FR) *La coupelle, les vis et le câble sont inclus dans l'emballage seulement si nécessaire pour le modèle de volant choisi. S'ils ne sont pas inclus, veuillez utiliser les composants disponibles dans l'emballage du moyeu MOMO.
(DE) *Haltering, Schrauben und Kabel sind nur mitgeliefert wenn es für das ausgewählte Lenkrad erforderlich ist. In allen anderen Fällen müssen die in der MOMO Nabenverpackung enthaltenen Teile verwendet werden.
(ES) *El anillo de sujeción del botón, los tornillos y el cable están incluidos en el envase solo si son necesarios para el modelo de volante elegido. En caso contrario, utilice los componentes disponibles en el envase del cubo MOMO.

5A-5B-5C
Opzioni di collegamento alternative
 Alternative connection options
 Options de connections
 Alternative Anschlussmöglichkeiten
 Opciones de conexion alternativa

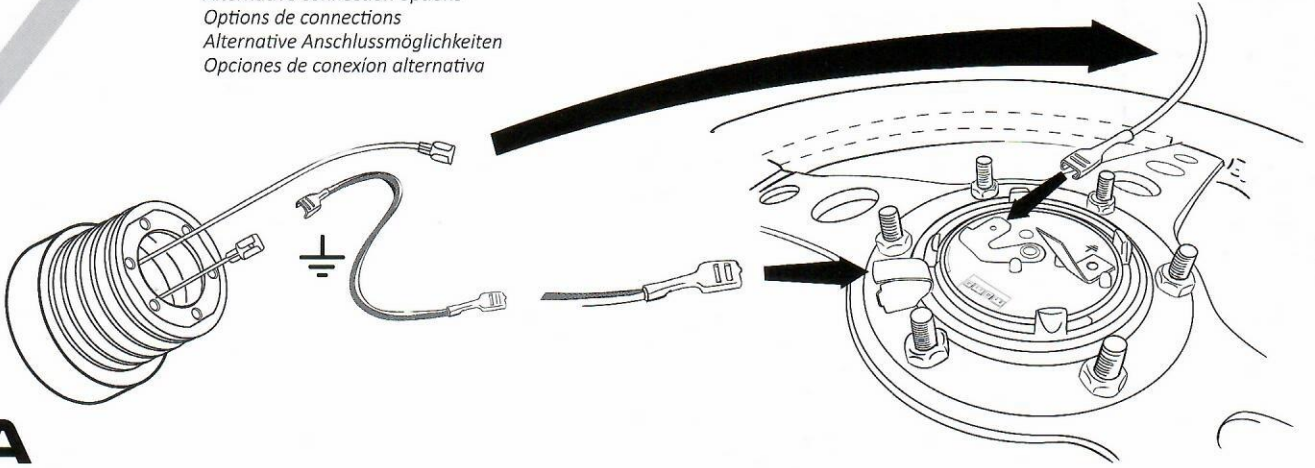

5A

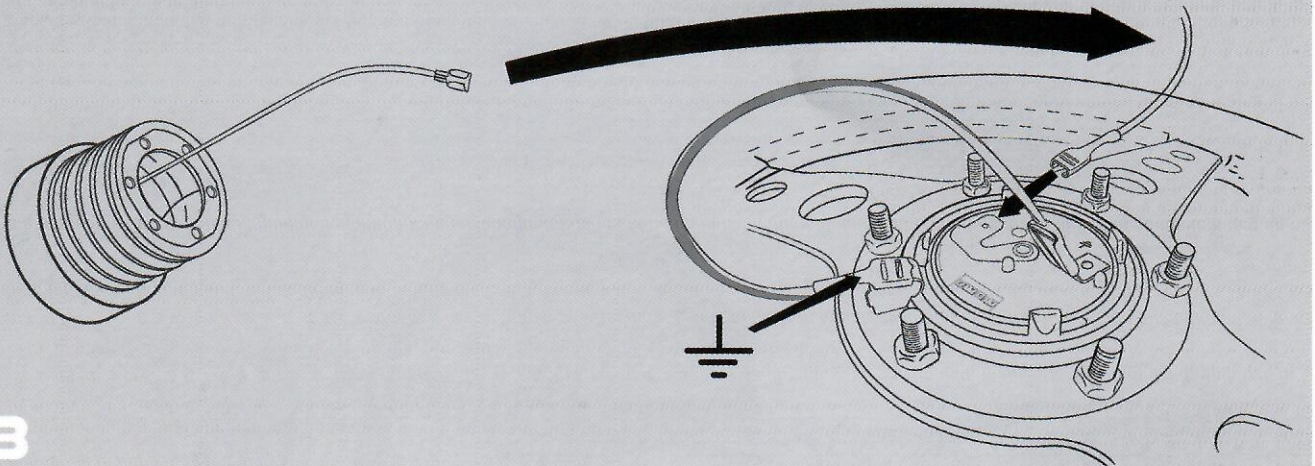

5B

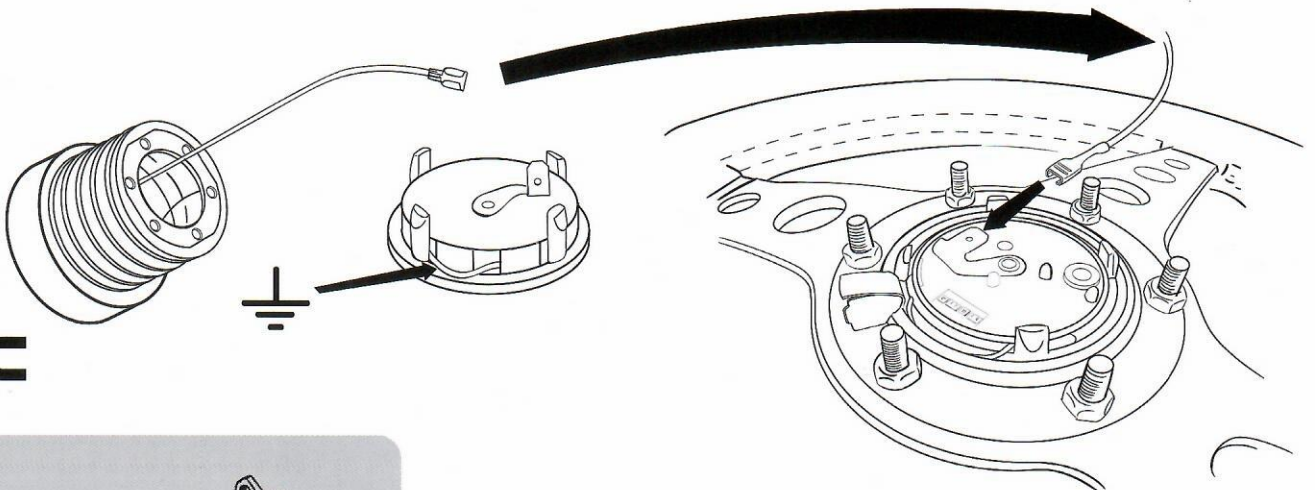

5C

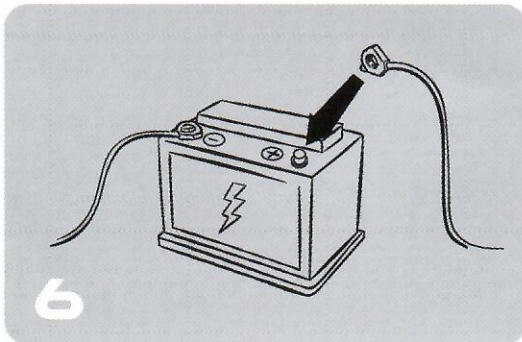

Dopo aver percorso qualche chilometro, controllare le 6 viti e stringerle, se necessario.

After driving a few miles make sure that the six screws are properly tightened and, if necessary, fasten them.

Après avoir roulé quelques kilometres, contrôler la bonne fixation des 6 vis et les revisser si nécessaire.

Nach den ersten Kilometern stellen Sie sicher, daß die 6 Schrauben korrekt befestigt sind und, wenn nötig, ziehen Sie diese nach.

Después de conducir unas pocas millas, compruebe los seis tornillos y apriete si es necesario.



MOMO SRL
 VIA WINCKELMANN 2, 20146 MILANO - ITALIA TEL: +39 02 424112 - FAX: +39 02 42411299

MOMO AUTOMOTIVE ACCESSORIES INC.
 HEADQUARTERS: 3155 WEST BIG BEAVER ROAD SUITE 11B, TROY, MICHIGAN 48064, USA

WEST COAST OFFICE: 27 MUSICK, IRVINE, CALIFORNIA 92618, USA
 PHONE: +1 (949) 380 7556 / TOLL FREE: 800-749-MOMO

WWW.MOMO.COM

