

Instruction Manual

Attached Warranty Card

▲ Please keep the Instruction and the warranty Card carefully for further reference. Please read all instructions before using the device.

I. Cautions (The following basic safety precautions should be always complied with)

Avoid casualties and property loss, please always follow the attentions as the following.

Warning May cause electric shock or fire hazard.



Prohibition

Installing

1. Do not use unsafe plug or power.
2. Do not install the device at the place where children can touch.
3. Do not install the device at the place where can not bear strength and prone result in falling and collapsing.
4. Do not tilt the device.
5. Keep the device away from fire and heat source, prohibit to store flammable and explosive materials around the device.
6. Except for the atomizer, the housing material is not resistant to corrosion.
7. Do not use device in high temperature or wet environment.
8. Do not use inflammable, explosive, corrosive and other hazardous solvents work with the device.

Note May cause personal injury or property damage



Necessary

Installing

1. Ensure the firmness of installation area.
2. Install the device in a ventilative and adequate space.
3. Do not block the sprayer by hand or other obstructions when the device is working.
4. Do not spill water or conductive, corrosive liquid on the device surface or fall inside of the device.
5. Do not operate device without stopping. Suggested average daily usage time should not exceed 14 hours, and the second level is recommended.
6. Cut off the power in extreme weather environment.

II. Instruction

Approved Certificate: CE、FCC、RoHS、CNAS and so on.

Application Place: Hotel、4S Car store、Brand Shop、Bar、Public Area and so on.

III. Schematic diagram of connecting air-conditioning duct

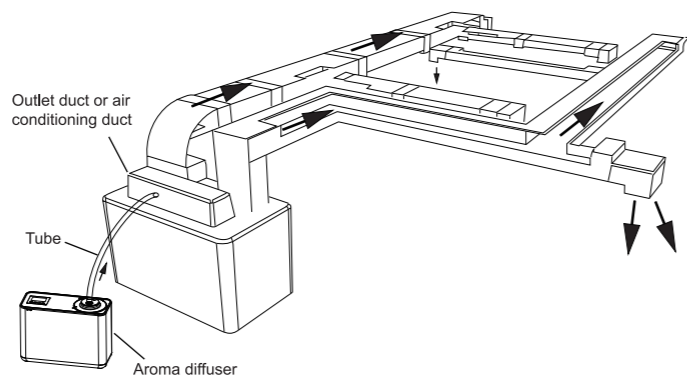

IV. Operation Introduction

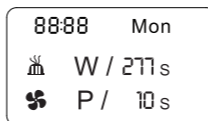

1. The device has four buttons: " " is the return button " " is confirmation button, " " is the increasing button and " " is the shift button.

2. Buttons operation:

Under the normal working interface, press " " and " " buttons at the same time to enter the password setting interface.

3. Under the normal working interface, press " " and " " buttons at the same time to enter local time setting interface.

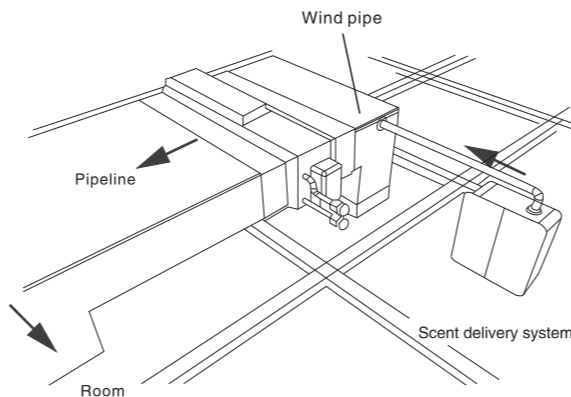

4. Under the normal working interface, press " " button to enter the working time and frequency setting interface.

5. Under the normal working interface, long press " " button to turn on/off the fan.

6. Under the normal working interface, long press " " button to turn off the machine.

Factory Reset:

Under the normal working interface, firstly, press the " " and " " buttons at the same time until the interface show YES/NO, then let your hand go. Secondly, operate " " to choose YES then press " " button to confirm it and finish the setting.

V. The main common problems after long-time not using.

Reason

Solution

1. The PCB can not work

- a. PCB damage.
- b. The battery is dead.
- c. PCB poor welding, resulting in insensitive contact.
- d. Power cut off.

- A. Change the PCB.
- B. Replace the battery.
- C. Replace the PCB.
- D. Check the adapter and power cable.

2. Equipment can not work, but the PCB display normally

- a. The pump system is broken.
- b. Time setting.
- c. Inner circuit problems.

- A. Change a pump.
- B. Check the time setting.
- C. Check the inner circuit(multimeter).

3. Abnormal Noise

- a. Pump is broken, aged or loose.
- b. Trachea cable connection occurs problems.
- c. Internal structure is damaged.

- A. Adjust or Change a pump.
- B. Check the cable connection.
- C. Adjust or change parts.

4. Machine works but no scent or scent is weak

- a. The nozzle is blocked.
- b. The pipette falls off.
- c. The pump system is aged.
- d. The atomizer is blocked.
- e. There are impurities in the essential oil.

- A. Change a nozzle(First with alcohol soak for a few minutes) or with a fine needle to clear the nozzle.
- B. Reconnect the pipette.
- C. Change a pump.
- D. Clean the atomizer.
- E. Replace with pure essential oil.

5. Oil Leakage

- a. The equipment is tilted.
- b. The atomizer leaks.

- A. Put the machine straight.
- B. Change a new atomizer.

VI. Accessories and spare parts

Please clean the equipment periodically, suggest 2-3 months in 1 circle, so that it can work under best condition.

Please cut off the power when cleaning, also do not use wet hand to operate it directly, in case of electric shock and injury.

1. Long-term non-use

- (1) Please turn off and cut off the power then roll up the power cord.
- (2) Clean the filter components.
- (3) Place the deodorant package which contains activated carbon in the device or package, to prevent residual substances in the equipment produce odor.
- (4) Please equip the machine with the dust cover, placed in the shade, ventilative place.

VII. Accessories and spare parts

Name	Quantity	Name	Quantity
Aroma diffuser	1PC	Screws (including plastic expansion tube)	2PC
Adapter	1PC	Manual	1PC
Cap	1PC	Warranty card	1PC
Air conditioning tube	1PC	Bottle sealing gasket	1PC
Key	2PC		
Connector	1PC		

VIII. After-sales Service

1. Provide free technical solutions and installation process guidance.
2. Provide free online FAQ consultation and scent-marketing suggestion.

IX. The equipment warranty and precautions

1. The equipment warranty period is 12 months (from the date of sale).
2. Please provide the warranty card, Invoice or other provement which can prove the equipment was ordered in our company to enjoy the free maintenance.
3. The human error or other wrong operation cause the fault not belong to the scope of warranty, and will not be accepted to provide free maintenance.

产品使用说明书

另附保修卡

- ▲ 请妥善保管说明书和保修卡，以备需要时查阅。
使用前请务必仔细阅读(安全注意事项)。

一、安全上的注意事项 务必遵照下述注意事项

为了避免危害使用者以及给他人造成财产损失，特此说明下列务必遵守的事项。

警告 有可能发生触电或火灾的事项。

安装时

1. 请勿使用不安全电源插头，电线。
2. 请勿将香氛设备安装于儿童能触及的地方使用。
3. 请勿将香氛设备安装在承重强度不够或者易出现坠落，坍塌的位置。
4. 请勿将设备倾斜。
5. 请勿使香氛设备接近火源、热源，禁止在香氛设备附近使用或存放易燃易爆物品。
6. 请勿将香氛设备放置于高温潮湿的环境中使用。
7. 请勿使用易燃、易爆、有腐蚀性等危害溶剂给设备工作。



禁止

注意 有可能发生人身伤害或损坏财产的事项。

使用时

1. 需要保证设备安装时的牢固性。
2. 设备安装附近应保持相对的通风和适度的空间。
3. 请勿在设备工作时用手或其他障碍物去堵塞出雾口。
4. 请勿将水或者有导电性、腐蚀性液体洒在香氛设备表面或者内部。
5. 请勿过度连续使用本设备，建议日均使用时间不超过14小时，且推荐第二档。
6. 如果设备在极端气候或者环境出现异常，请及时选择安全的方式切断电源。

二、产品说明

产品通过：CE、FCC、RoHS、CNAS、等认证。
本产品主要适用于：酒店、汽车4S店、品牌专营店、酒吧、公共消费场所等室内场所。

三、连接空调管道示意图

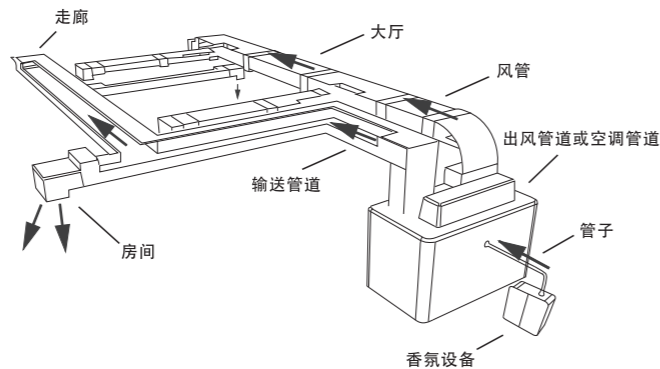

四、操作说明

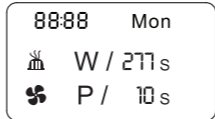

产品有四个按键：“”“”“”“”，“”为返回键，“”为确认键，“”为增加键，“”为位移键。

3. 按键功能键操作：

- 正常界面：按下“”+“”键，进入密码设置界面。
正常界面：同时按下“”+“”键进入当地时间设置。
正常工作界面：单按“”进入每天工作起止时间与频率设置界面，可设置五段工作时间和工作频率。
正常界面：长按“”，可关闭风扇工作。
正常界面：长按“”键，便可关机。
恢复出厂设置操作：
正常界面，同时按下“”+“”键，直到设备显示YES/NO界面，再松开手，按“”位移键选择YES，再按“”确认，便可对设备进行恢复出厂初始化。

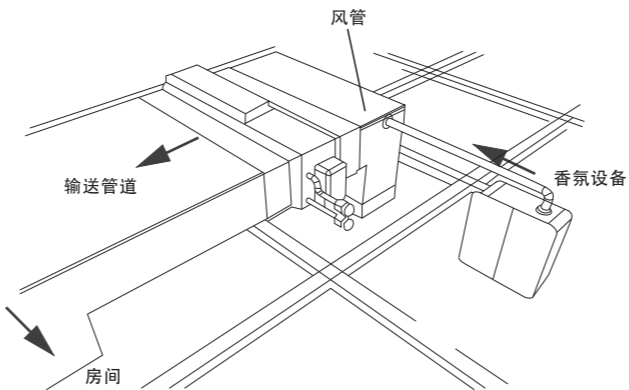

五、疑问解答

原因

1. 电路板不工作

- a. 电路板程序烧毁
- b. 电池没电
- c. 元器件（电路板里面的零件）虚焊，导致接触不良
- d. 电源断电

2. 电路板显示正常但是设备不工作，无声响

- a. 气泵损坏
- b. 时间设置
- c. 内部电路问题

3. 设备正常工作但是不雾化或者雾化量小

- a. 雾化芯堵死
- b. 吸液管脱落
- c. 气泵老化
- d. 雾化头堵死
- e. 精油有杂质

解决措施

- A. 更换电路板
- B. 更换电池
- C. 更换电路板
- D. 检查适配器电源

- A. 更换气泵
- B. 检查时间设置
- C. 检查内部电路（万用表）

- A. 更换雾化芯（先用酒精浸泡几分钟）或者用细针疏通雾化芯
- B. 重新接上吸液管
- C. 更换气泵
- D. 清理雾化头
- E. 更换为纯液体精油

原因

4. 设备声音异常

- a. 气泵损坏或老化或松动
- b. 气路连接问题
- c. 内部结构受损

5. 设备漏油

- a. 设备倾斜
- b. 雾化头漏油

解决措施

- A. 调整或更换气泵
- B. 检查气路
- C. 调整或更换零部件

- A. 设备摆正
- B. 更换雾化头

六、保养维护

- (1). 为了维持设备的最佳工作状态，必须定期对设备进行清洁，清洁周期为：2-3个月。
- (2). 清洁时必须拔下插头，不要用湿手拔取，否则会造成触电和受伤。
- (3). 请勿在设备通电或者工作的情况下进行维护。
- (4). 若设备出现精油泄露或者倾侧外溢的状况，应该选择安全的方式切断电源，且不可用手去触摸泄露的液体或溶剂。

1. 长期不使用

- (1). 请先关机，拔掉电源插头，将电源线卷扎好。
- (2). 清洁过滤网零部件。
- (3). 将含有活性炭成分的除臭包置于设备或包装内，防止设备内残留物质变质产生异味。
- (4). 盖上防尘罩，放置在阴凉处、通风处。

七、装箱清单

名称	数量	名称	数量
香氛设备	1台	螺钉（含塑料膨胀管）	2颗
适配器	1个	说明书	1本
瓶盖	1个	保修卡	1张
空调管	1条	瓶口密封垫片	1片
钥匙	2把		
气动接头	1个		

八、售后服务和保修

1. 售后服务

- (1) 免费提供技术解答与安装流程。
- (2) 在线免费提供香氛效果跟踪方案。

2. 设备质保及注意事项

- (1) 产品质保周期为12个月（从售出当天开始计算）。
- (2) 提供保修卡、发票及相关证明才能享受免费维修。
- (3) 产品人为损坏及使用不当造成的故障不在保修范围内。