



# Owner's Manual

Contents

**INTRODUCTION** \_\_\_\_\_ **2**

**GENERAL SAFETY** \_\_\_\_\_ **3**

    Safety Warnings \_\_\_\_\_ **3**

**INSTRUCTIONS** \_\_\_\_\_ **5**

    Pedestal Mount \_\_\_\_\_ **5**

    Air Escape/Drainage Hole \_\_\_\_\_ **5**

    Selecting a Motor and Battery \_\_\_\_\_ **6**

    Transporting \_\_\_\_\_ **6**

    Launching \_\_\_\_\_ **6**

    Steering \_\_\_\_\_ **6**

    Storing \_\_\_\_\_ **7**

**GENERAL CARE AND MAINTENANCE** \_\_\_\_\_ **7**

**REGISTERING YOUR ULTRASKIFF IN YOUR STATE** \_\_\_\_\_ **8**

    Attaching Registration Numbers to You Ultraskiff \_\_\_\_\_ **8**

**MANUFACTURERS LIMITED WARRANTY** \_\_\_\_\_ **9**

    To Whom Does This Limited Warranty Apply? \_\_\_\_\_ **9**

    What Does This Limited Warranty Cover? \_\_\_\_\_ **9**

    What is the Coverage Period? \_\_\_\_\_ **9**

    How the Warranty Process Works \_\_\_\_\_ **10**

    What the Warranty Doesn't Cover. \_\_\_\_\_ **10**

**Limitation On Damages.** \_\_\_\_\_ **12**

**How Does State Law Apply?** \_\_\_\_\_ **13**

## INTRODUCTION

Congratulations on your new boat! The Ultraskiff will give you years of boating enjoyment with minimal prescribed care. With a bit of education and experience, it offers a fantastic set of benefits for you. To begin your adventure, check your state/county maps for public lands with appropriately sized bodies of water where you can use your watercraft. Other boaters are your best source of information regarding put-ins, take-outs, trips, and where to find local honey holes.

For additional tips and instructions about using this product or more information about accessories and their installations not seen in this booklet, please visit our website at [www.Ultraskiff.com](http://www.Ultraskiff.com).

## GENERAL SAFETY

Boating enables people of all ages and abilities unrivaled opportunities to experience the great outdoors. However, while you can choose a long or short trip, even the most straightforward outing can quickly lead to danger without proper precautions. No matter what type of watercraft you are using, there are basics every boater should know:

- Always wear an appropriately rated and sized personal floatation device (PFD).
- Consult local tide charts and maps, talk to experts and be aware of weather forecasts.
- Let people know where you plan to go and when you plan to return.
- Learn your craft: start slow and seek proper instruction.
- Practice your skills, rescues, and first aid techniques in various conditions until you are thoroughly familiar with them.
- Dress for the water temperature. Weather conditions can change quickly, turning a warm afternoon ride into a challenge to remember.
- If you prepare to get wet, you'll stay warm whatever nature brings your way!
- Protect yourself by learning to read water and weather, and never leave shore in conditions for which you are unprepared.
- Finally, be on the lookout for potential hazards such as other boats, weather, and other natural dangers.

These boating basics will help keep you safe, warm, and just where you want to be—on the water!

### Safety Warnings

The Ultraskiff is a uniquely designed watercraft designed to be self-stabilizing, portable, and easy to maneuver. However, until you become accustomed to the boat, you should operate cautiously and follow these safety standards. Also, you should be aware that participating in any boating activity has the potential to be dangerous and could involve severe injury or death. Therefore, we've included these safety standards to help you mitigate the risk as much as possible.

- Read the owner's manual before using the Ultraskiff.
- Only use a deep-cycle battery stored in the battery compartment with a transom-mounted trolling motor attached to the transom.
- Follow the manufacturer's recommendations for the proper use of the product.
- Get boating instruction from a licensed or certified instructor.
- Obtain certified first aid and rescue training and carry first aid and rescue equipment.
- Always wear a nationally-approved personal floatation device (PFD).

- Dress appropriately for weather conditions; cold water and cold weather can result in hypothermia.
- Check your equipment before each use for signs of wear or failure.
- Always let someone know when and where you are boating in case of an emergency.
- Do not use alcohol or mind-altering drugs while using the Ultraskiff.
- Do not operate watercraft in hazardous or flood conditions.
- Be aware of appropriate river water levels, tidal changes, dangerous currents, and weather changes.
- Scout unfamiliar waters and portage whenever possible.
- Do not exceed your navigating ability.
- If you add more outfitting to this craft, use the manufacturer's approved materials only. Do not impair entry or exit access.
- Make sure the boat is well-secured to your vehicle or trailer before transporting.
- Pay close attention to the amount of battery power available before and during operation. Pre-plan trip and course accordingly.
- This boat is intended for slow-moving or calm bodies of water.
- Keep a safe distance from all boat traffic and their wake.
- Use caution when exiting, entering, or standing on the boat.
- Monitor your trim when loading the boat. Keep the trim as level as possible and compensate for added weight by moving batteries and supplies around to the appropriate compartments.
- Use caution and keep away from the motor when climbing into the boat from the water.
- Do not use a boat if you suspect a crack or hole; it may be unsafe.
- Do not use this boat as a tow-craft.

*You acknowledge both an understanding and an assumption of the risk involved. If you have any questions about this or any of our products, do not hesitate to call us.*

## INSTRUCTIONS

### Pedestal Mount

The pedestal mount comes with the necessary stainless-steel hardware for attaching a pedestal base. If you are unsure how to secure your pedestal base to your pedestal mount properly, watch our main promotional video or contact us directly. Next, tighten the nylon lock nuts snug against the washer. **DO NOT OVERTIGHTEN.** If you see the plastic underside of the pedestal bend or change shape when tightening the nut, you have over-tightened and should release pressure immediately so you do not damage the pedestal mount. For 5'6" tall and under, we recommend the II" pedestal (post/pole). For anyone over 5'7", a 13"+ sized pedestal is recommended.

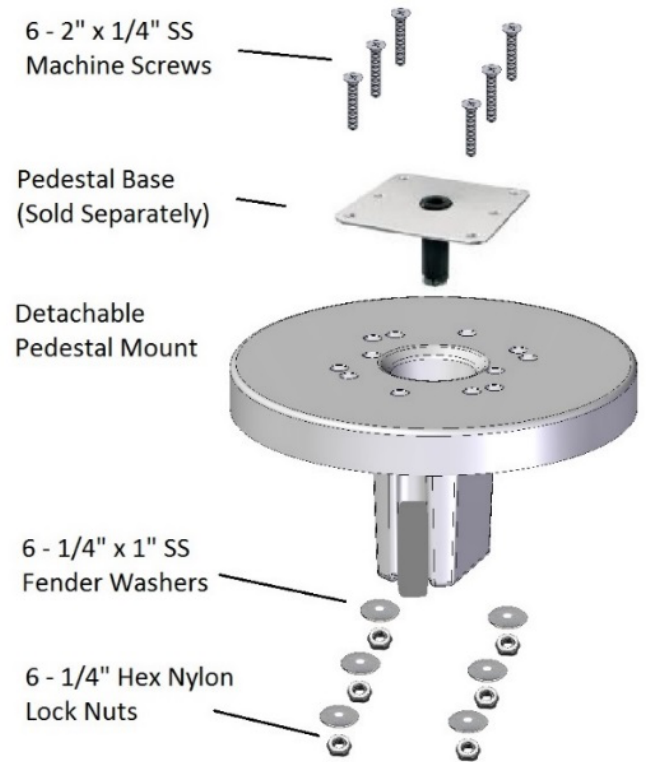

### Air Escape/Drainage Hole

The Ultraskiff does not have a drainage plug, but it does have a small hole drilled in an area that prevents water from entering but can be used to drain water from the hull. You should not float the boat upside down because water will enter the hull. This hole also allows air to escape so the boat can breathe. If you leave the boat in the hot sun for long periods, the air can expand inside the hull and deform the plastic. The drainage hole allows air to escape, preventing damage.

The drainage hole is at the top of the gunwale, as shown in the diagram to the right. The rounded edge prevents rainwater from entering through the hole. To drain the boat, simply turn it on its side, so the hole is directly over the ground, and tilt the boat until water begins to drain out. Contact us if you need further instructions.

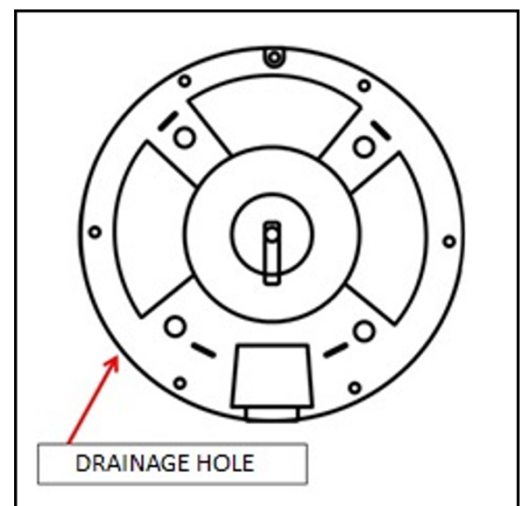

## Selecting a Motor and Battery

This boat is designed for use with a transom-mounted trolling motor that uses a deep-cycle battery. The boat was designed to work with a 45 - 55 lb. thrust trolling motor, and the ideal motor is a 12V 55 lb. thrust 36" or 42" shaft trolling motor. The recommended battery size is a 12V Deep cycle battery size group DC24-32. The boat's balance and performance are engineered to keep a deep cycle battery in the battery compartment during operation.

## Transporting

You can easily transport 1 or 2 boats using a pick-up truck or small utility trailer. If using a trailer, a simple flatbed utility trailer works better than a conventional boat trailer. **Do not over tighten tie-down straps.** If the tension is too high and the temperature is warm, the straps may cause dents in the hull. If you are storing your Ultraskiff on a trailer, be sure to relax the tension on the straps. When securing the boat on a vehicle or trailer, always use quality, clean, and fully functioning ratchet straps. If you are traveling any significant distance, we recommend periodically pulling over to inspect the straps to see if they need tightening. Ratchet straps will loosen up over time while driving. It is not recommended to put the boat on top of a vehicle's roof rack. The only appropriate roof rack would be a heavy-duty Thule roof rack wide enough to support the Ultraskiff. If you are using a Thule roof rack, you will need to use at least 6-8 ratchet straps, with each one running through the center hole. It is a lot of work to properly strap one of these boats on top of a vehicle which is why we recommend just getting a small trailer to transport your Ultraskiff. Use foam or other protective measures on the straps to cushion the boat from any possible damage which may be caused by straps that may be too tight or driving through bumpy or rough conditions.

## Launching

You can launch the boat from shorelines, boat ramps, stationary docks, and floating docks. When launching from a beach or shoreline, it is best to roll the boat on its side or use a hand truck to wheel the boat to the water. For tips on rolling the Ultraskiff or using a hand truck, visit our instructional videos at [www.ultraskiff.com](http://www.ultraskiff.com).

## Steering

If you do not have experience steering a boat with a tiller handle, it will take practice to get a feel for steering the Ultraskiff. You will want to avoid moving the tiller in wide swings because it will turn the boat faster than expected, and you will compensate for the swing by swinging the other direction, so and so forth repeatedly, without staying a course. For example, to make a right turn, you only need to nudge the tiller in one direction until the center strap guide (bow) and the tiller are lined up with your direction. Once you get a feel for it, it becomes second nature to steer and control the boat without much effort.

Staying on course is just a matter of keeping the tiller arm at 12 o'clock. In other words: keep the tiller arm facing the seat pedestal and keep your bow/tow ring facing toward the object or direction you want to go. With most lightweight boats, the wind or currents will push you slightly off course during travel. Correct your course by slightly nudging the tiller until your alignment is once again attained. When turning the boat with the tiller, the key is, once you align the bow/tow ring with your direction of travel or ultimate destination, quickly move the tiller back to 12:00, facing the seat pedestal. Avoid moving the tiller too far in either direction or not putting the tiller back to 12:00 at the right time when adjusting your course.

## Storing

The Ultraskiff is made with the same process and materials as a typical kayak. They may be stored outside but keep in mind; plastic boats are not immune to the effects of the sun or the effects of extreme cold temperatures. Excessive heat causes plastic boats and kayaks to droop when stored. Winter can be very hard on boats. If possible, keep your boat in a garage or barn. When storing your boat outside, lay it on its side or upside down to prevent water and debris from accumulating inside the boat. UV rays can cause the plastic to fade and, in very extreme cases, damage the plastic. The best option is to store the Ultraskiff out of the elements.

When storing your boat, drain any water from the inside of the hull through the air escape/drainage hole (see page 5). Don't allow water to accumulate between the deck and hull and freeze. Remove the seats and store them inside. Do not store the boat filled with gear.

If you must store your Ultraskiff outside, be sure to keep the boat covered with a UV-protected tarp.

## GENERAL CARE AND MAINTENANCE

With minimal care and maintenance, the Ultraskiff will provide you with many years of enjoyment. The Ultraskiff is made from LLDPE Polyethylene, which is very impact-resistant, but vulnerable to excess abrasion, so avoid dragging the boat across gravel, asphalt, or concrete.

- Drain any water accumulated between your deck and hull.
- Release the tension from any winch or tie-down straps when not being transported.
- When necessary, clean your boat with warm water and any standard detergents.
- If you use your Ultraskiff in salt-water environments, rinse the boat and components thoroughly with fresh water after each use.
- Periodically inspect all bolts and screws to ensure proper performance and safety. The bolts and screws can become loose with use; simply re-tighten with a screwdriver.

- If you wear a hole in the boat below the waterline, LLDPE is very difficult to repair. Nothing sticks to LLDPE permanently other than molten LLDPE. There are many adhesives and resins on the market specifically for polyethylene and do an outstanding job on polyethylene, but nothing can be considered 100% permanent. Most adhesives, even those that are very aggressive, will only make a temporary bond and probably will not be waterproof.
- Polyethylene is a somewhat flexible material with some memory; it returns to its original molded shape if distorted. If this occurs, follow these steps:
  - Relieve the pressure that caused the dent or distortion by supporting the boat differently, removing gear/motor, etc.
  - Place the boat in the warm sun. Usually, the south side of a building is the warmest spot. As the boat warms up (usually but not always) the boat will return to its original molded shape. This process may take a few hours or a couple of weeks depending upon the temperature and degree of distortion.

## REGISTERING YOUR ULTRASKIFF IN YOUR STATE

Typically, all motorized watercraft must be titled and registered in their state of use. Therefore, it is recommended you use your title to properly register your Ultraskiff. In most states, you must bring your Manufacturers Statement of Origin (MSO) and a copy of your paid invoice to the local Department of Motor Vehicles (DMV). The Hull Identification Number (HIN) has been recorded on your paid invoice, engraved in the hull of your Ultraskiff and is listed on the MSO.

### Attaching Registration Numbers to Your Ultraskiff

Polyethylene plastic is a waxy resin that has a "low energy" surface, and it can be difficult to paint or to attach adhesive stickers to it. However, there are various tapes and adhesive wraps on the market that are specifically designed to attach to a low energy surface. To attach your registration numbers to the hull, you have the following options:

- Attach a low energy tape or wrap over the area, then attach your numbers over the tape or wrap.
- You can also use these other adhesives:
  - 3M high strength adhesive spray #76
  - 3M Scotch-Weld High performance industrial plastic adhesive 4693H and apply to the hull
  - 3M double-sided outdoor tape
  - Velcro Extreme heavy-duty titanium strips

If you want to permanently stencil your numbers onto the boat, we recommend using a permanent black marker. Be aware this makes it difficult or nearly impossible to ever remove



the traces of these numbers from the hull using a permanent marker. If you stencil your numbers onto the hull, you will still need to apply your registration sticker.

## MANUFACTURERS LIMITED WARRANTY

If you purchased your product prior to October 1, 2021, you'll need to register your watercraft in our warranty database. To do so, please go to:

<https://www.ultraskiff.com/register-your-product.html>.

If you purchased your Ultraskiff after October 1, 2021, Pond King, Inc. will have record of your transaction and no additional steps are necessary.

For complete warranty details, to provide notice of a warranty claim, or to request warranty service, contact Pond King by emailing [Ultraskiff@pondking.com](mailto:Ultraskiff@pondking.com) or by calling 940-668-2573.

As the sole and exclusive obligation under this Warranty of Pond King, Inc. and as Consumer's sole and exclusive remedy, upon prompt written notice from Consumer of breach of this limited Warranty during the relevant warranty period, Pond King will either, at Pond King's option,

- (a) repair or replace the defective product, or
- (b) refund the purchase price paid by Consumer if an inspection by Pond King discloses material defects in workmanship or material covered by this Warranty.

### **To Whom Does This Limited Warranty Apply?**

Pond King, Inc. extends the following limited Warranty to the original retail consumer only ("Consumer").

### **What Does This Limited Warranty Cover?**

This Warranty covers manufacturer defects in workmanship and materials in your new Ultraskiff products, with the exceptions stated below. Ultraskiff products include the Ultraskiff hull and the detachable pedestal mount.

### **What is the Coverage Period?**

The hull, and detachable pedestal mount of any Ultraskiff is covered for 365 days from the Consumer's original purchase date. For standard boats used for rental, demonstration, resort or outfitter purposes, the Warranty is 30 days from the date of delivery or manufacturer to the Consumer.

## How the Warranty Process Works.

1. The Ultraskiff must be registered.
  - a. If you purchased your product prior to October 1, 2021, you'll need to register your watercraft in our warranty database. To do so, please go to:  
<https://www.ultraskiff.com/register-your-product.html>.
  - b. If you purchased your Ultraskiff after October 1, 2021, Pond King, Inc. will have record of your transaction.
2. If you have a warranty claim, contact us at [Ultraskiff@pondking.com](mailto:Ultraskiff@pondking.com).
3. Be prepared to provide the following information:
  - a. Proof of purchase, date and place of purchase and original purchase price.
  - b. Boat HIN number, model, and color.
  - c. Consumer name, address, and phone number.
  - d. Detailed description of the problem.
4. If the problem or issue can be fixed, we will send you the materials and/or instructions on how to fix it. Or we may send a representative to fix it or have you bring the boat to an authorized repair center or representative to be repaired. We may ask you to send us the defective product at our cost. If the product is to be returned to Pond King, Inc, our Customer Service Department will issue a return authorization number. Please affix this number to the product along with your name and contact person. Please do not return any product to Pond King, Inc without a return authorization number. Return products in the original packing material or equivalent. Please include a note of explanation inside the package regarding the reason for the return, contact information and desired action.
5. The warranty period for a replacement boat or repaired boat, and the related product, shall be only the remaining portion of the original warranty period applicable to such product.
6. The consumer is responsible for any travel, freight or shipping costs when replacing or returning new or repaired products.

## What the Warranty Doesn't Cover.

There is NO WARRANTY, and no portion of warranty expense will be reimbursed when:

- Warranty claim is related to any defects other than clear and noticeable defects that originated during the molding process of manufacturing.
- Warranty claim is due to normal wear.
- Change in appearance of boat due to wear, exposure, or any other environmental condition.
- Product has ever been used for commercial use as a rental, demonstration watercraft, resort amenity, or in an outfitter organization.

- Damage caused by the transport or strapping of the product to a vehicle or trailer. This Warranty only covers claims resulting from on the water use.
- Warranty claim is due to or related to loosened or un-tightened screws on any of the accessories. It is the user's responsibility to monitor and tighten any loose or loosened parts.
- This Warranty does not cover any boats that have been moved or exported/imported outside of the continental United States.
- Product has ever been used with any other propulsion other than a transom-mounted trolling motor.
- The detachable pedestal mount was damaged by the over-tightening of bolts.
- The user has stripped or damaged any of the threaded inserts. Once you remove any of the screws attached to an insert it then voids any warranty for that part. Pond King, Inc is not responsible for inserts damaged by the user.
- The part being claimed is one of the 3 storage compartments, battery storage compartment or one of the 6 rod holders. We will only cover a warranty in these areas if there is a hole or leak that was present at the time of purchase and hole or leak in question is the result of a defect created during the molding process. It is the responsibility of the consumer to inspect these parts and make sure there are no defects upon initial purchase or receipt of product.
- The walls and floors of these areas could be punctured by the improper handling of heavy or sharp objects. This Warranty does not cover damage to any of these areas.
- Product is determined by Pond King to have been subjected to unusual or abnormal use, misuse, abuse, negligence, accidents, normal wear and tear, damage due to environmental or natural elements such as weather and temperature, failure to follow Pond King's instructions, unauthorized repair, incorrectly performed maintenance or repair, improper installation, or storage.
- The transom or any other area is damaged from the use of a motor without the outfitted transom protection plates installed. The Ultraskiff comes equipped with transom protection plates. It is the consumer's responsibility to make sure these plates are secured tightly to the transom.
- Product is determined to have been used for any activity other than that which is customary for this type of product.
- Claim is made by any party other than the original purchaser of a product.
- Claim is related to or caused by any use or activity other than on the water use.
- Product was damaged while in possession of freight carrier, dealer, consumer, or any party other than Ultraskiff.
- Product was modified in any way.

- Product was not manufactured by Ultraskiff.
- Travel, freight or shipping costs when replacing or returning new or repaired products.
- For this Warranty to apply, the Consumer must retain and provide to Pond King receipts showing the date of product purchase and documented proper maintenance. Any oral or written description of the products is for the sole purpose of identifying the products shall not be construed as express Warranty.

Prior to using the products, Consumer shall determine the suitability of the products for the intended use and Consumer assumes all risk and liability in connection therewith.

POND KING SHALL NOT BE LIABLE TO CONSUMER, OR TO ANYONE CLAIMING UNDER CONSUMER, FOR ANY OTHER OBLIGATIONS OR LIABILITIES, INCLUDING, BUT NOT LIMITED TO, OBLIGATIONS OR LIABILITIES ARISING OUT OF BREACH OF CONTRACT OR WARRANTY, NEGLIGENCE OR OTHER TORT OR ANY THEORY OF STRICT LIABILITY, WITH RESPECT TO THE PRODUCTS OR ULTRASKIFFS' ACTS OR OMISSIONS OR OTHERWISE. THE EXPRESS WARRANTIES DESCRIBED HEREIN ARE EXCLUSIVE AND IN LIEU OF ALL OTHER EXPRESS WARRANTIES. FOR COMMERCIAL PRODUCTS, ALL WARRANTIES IMPLIED BY LAW, INCLUDING WITHOUT LIMITATION THE IMPLIED WARRANTIES OF MERCHANTABILITY AND FITNESS FOR A PARTICULAR PURPOSE, ARE DISCLAIMED AND SHALL NOT APPLY. FOR CONSUMER PRODUCTS, WARRANTIES IMPLIED BY LAW, INCLUDING WITHOUT LIMITATION THOSE OF MERCHANTABILITY AND FITNESS FOR A PARTICULAR PURPOSE, ARE EXPRESSLY LIMITED TO THE PERIOD OF THE WARRANTY STATED ABOVE FOR THE RELEVANT PRODUCT. Some states do not allow limitations on how long an implied warranty lasts, so the above limitation may not apply to you.

Any assistance Pond King provides to or procures for Consumer outside the terms, limitations, or exclusions of this Warranty will not constitute a waiver of the terms, limitations, or exclusions of this limited Warranty, nor will such assistance extend or revive the Warranty. Ultraskiff will not reimburse Consumer for any expenses incurred by Consumer in repairing, correcting, or replacing any defective products, except those incurred with Pond King's prior written permission.

#### [Limitation On Damages.](#)

IN NO EVENT SHALL ULTRASKIFF BE LIABLE FOR INCIDENTAL, COMPENSATORY, PUNITIVE, CONSEQUENTIAL, INDIRECT, SPECIAL OR OTHER DAMAGES. ULTRASKIFF'S AGGREGATE LIABILITY WITH RESPECT TO A DEFECTIVE PRODUCT

SHALL BE LIMITED TO AN AMOUNT EQUAL TO THE CONSUMER'S ORIGINAL PURCHASE PRICE PAID FOR THAT DEFECTIVE PRODUCT.

Some states do not allow the exclusion or limitation of incidental and consequential damages so the above limitation or exclusion may not apply to you.

### How Does State Law Apply?

This Warranty gives you specific legal rights, and you may also have other rights which vary from state to state. It is the express wish of the parties that this Agreement and any related documents be drafted in English.

Visit our websites for information on maintenance, transportation, storage, instruction, equipment recommendations, and more!