

# Bowaters

## MODELS

specialising in distinctive 16mm models

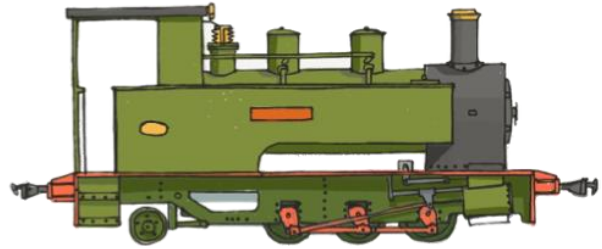

### Bowaters Models – BMH Series Instructions Brake Coaches (2090/2091)



#### Requires

- Accucraft Chopper Couplings (Z1 or Z2)
- IP Engineering Large Laser Cut Bogies (Own Choice of Gauge)
- 2-3 A3 pieces of Craft paper
- Glazing Material

#### Required Tools

- Fine Sandpaper/Emery Paper or Boards
- Small Files
- PVA Glue
- Super Glue
- Sharp Craft Knife

Version 2.0

## Prototype Information

For the opening of the rebuilt Welsh Highland Railway, a set of 5 new coaches were built. These consisted of 1 Semi Open (2020), 3 Saloons (2040-2042) and 1 brake coach (2090). All 5 were built by Winson Engineering. The Brake Coach was later rebuilt by the WHR into a half service car/passenger coach in 2009. The original Semi-Open was rebuilt into a sister of Service Car '2010' being renumbered '2011' in 2010-2011. Bar the rebuilt '2020', all coaches can be modelled by the Bowaters Model Range.

A few years later as traffic grew, two additional Semi Opens were built by Alan Keef in 2002 numbered 2021 and 2022. These were both rebuilt over the winters of 2012-2014 to include central glazed sections and vinyl covered seats. This marked the end of WHR being completely built by outside contractors. Both forms of these coaches can be modelled by the Bowaters Models Range

In 2006-2007, Boston Lodge built 3 longer saloons numbered 2043 to 2045. These were 1m longer than the Winson Coaches. These haven't been majorly rebuilt at the time of writing, so they are considered to be in 'as built condition'. In 2013-2014, a additional coach was built to a modified design with panramic windows numbered 2046. This coach was later cloned between 2016-2017 with the latest Saloon number 2047. All 5 of these coaches can be modelled by the Bowaters Models Range.

Built between 2043 and 2046, the WHR built a pair of coaches: Service Car 2010 and Pullman 2100 'Glaslyn'. 2010 was a change of direction for the combined FR/WHR in that all the facilities needed for the train were now in one coach and as a result, there was no need for a guards compartment in the end coach. Glaslyn was built as a end of train Observation Coach featuring a unique curved end. 2010 and 2100 can be modelled by the Bowaters Models Range.

Built at the same time as the original Winson Coaches, the WHR's first Pullman Coach 'Bodysgallen' entered service in 1998 after its Winson sisters. The coach was used to test the bogies for 2010 and 2100 having been converted from SAR bogies to Romanian bogies. After a period, it was switched back. The coach can be modelled as part of the Bowaters Models Range.

## About the Kit

The kit is a wooden kit comprising of a set of laser cut wooden parts.

## Chassis Fitting

This kit is designed for IP Engineering Large Laser Cut Bogies. These are assembled as per the instructions with no modifications required. On the top chassis piece, normally distinguishable by the laser cut detailing on the top surface, flip it over so the detailing is facing down. Then draw a straight line down the centre of the piece lengthways. This is needed so that once the chassis has been assembled, the correct position of the bogies can be achieved. They should normally be added once the chassis has been assembled and should be placed 90mm along the line from each end of the coach. Alternatively, you can attach the bogies closer to the end of the coach to dramatically reduce the minimum radius.

## Couplings

This kit is designed to take Accucraft Chopper Couplings (available separately as Accucraft part number Z1/Z2). These should be attached into the flat sections below the main coach bodies. These have been positioned so as to be at the correct height for the 16mm Association standard coupling height. We strongly recommend setting the coupling height against your existing motive power fleet.

### Instruction notes

With these instructions, there are images which show various stages of the construction of one of our coach kits. They are of the digital test build for brake coach 2090 which may not be representative of the kit you have bought. They are for reference purposes only.

### Painting

Over the time period the coaches we have produced have operated, they have carried only 1 paint scheme.

- 1997 - Present - Modern WHR/FR Coach Paint Scheme of Cream and Maroon (Closest matches are Humbrol 20 (Crimson Gloss) and 41 (Ivory))
- Bodysgallen – Classic Pullman Livery of Cream and Brown

## Please Turn over

Please read though these instructions before beginning to assemble your kit

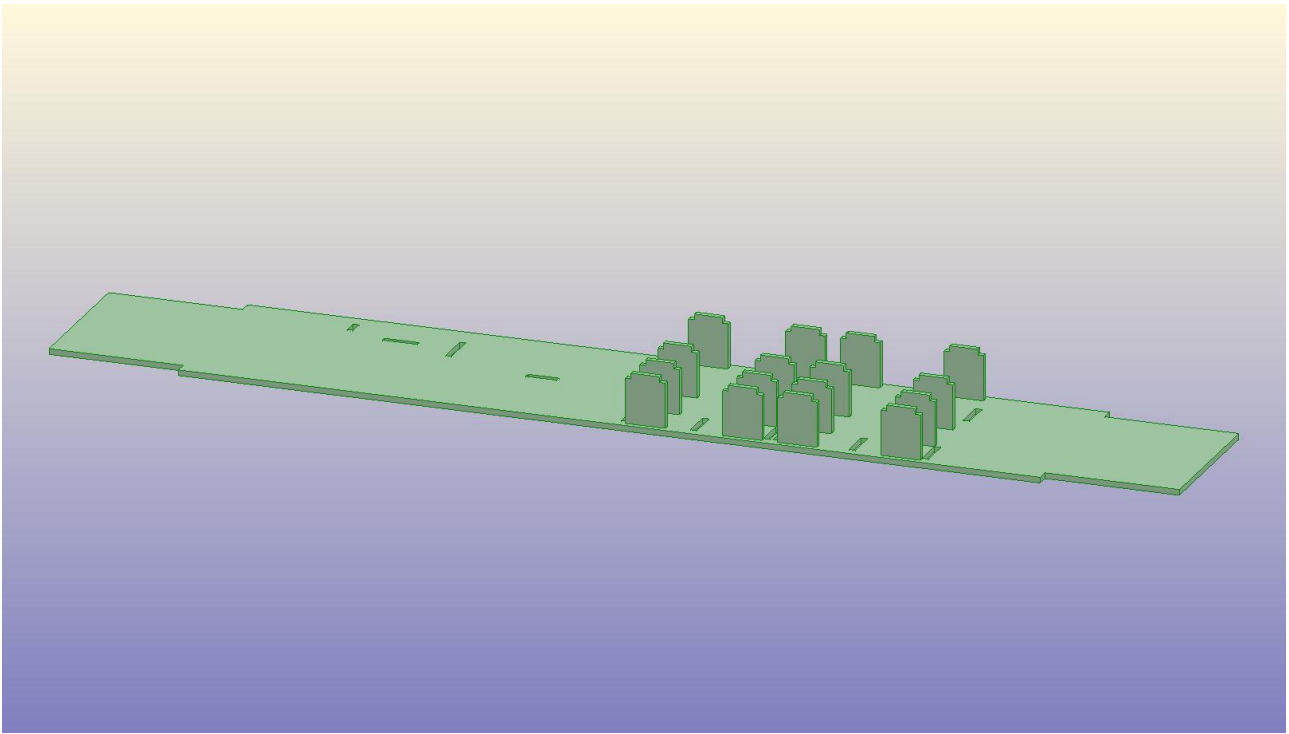

*Start by gluing the seat supports into their slots on the chassis plate. These are the smaller of the similarly shaped components (the larger ones are the table supports).*

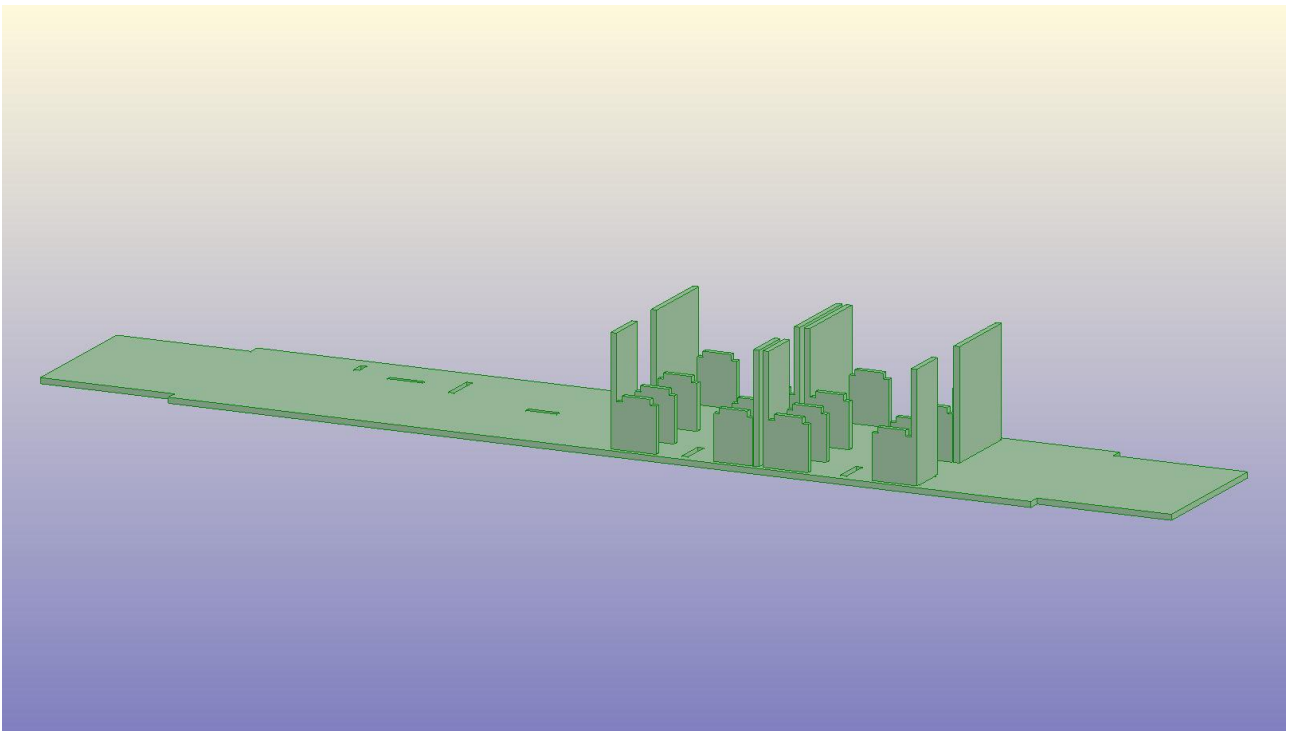

*Next, glue in the seat backs into their slots on the chassis plate. These will slot between the seat supports where there is a group of 4 supports together.*

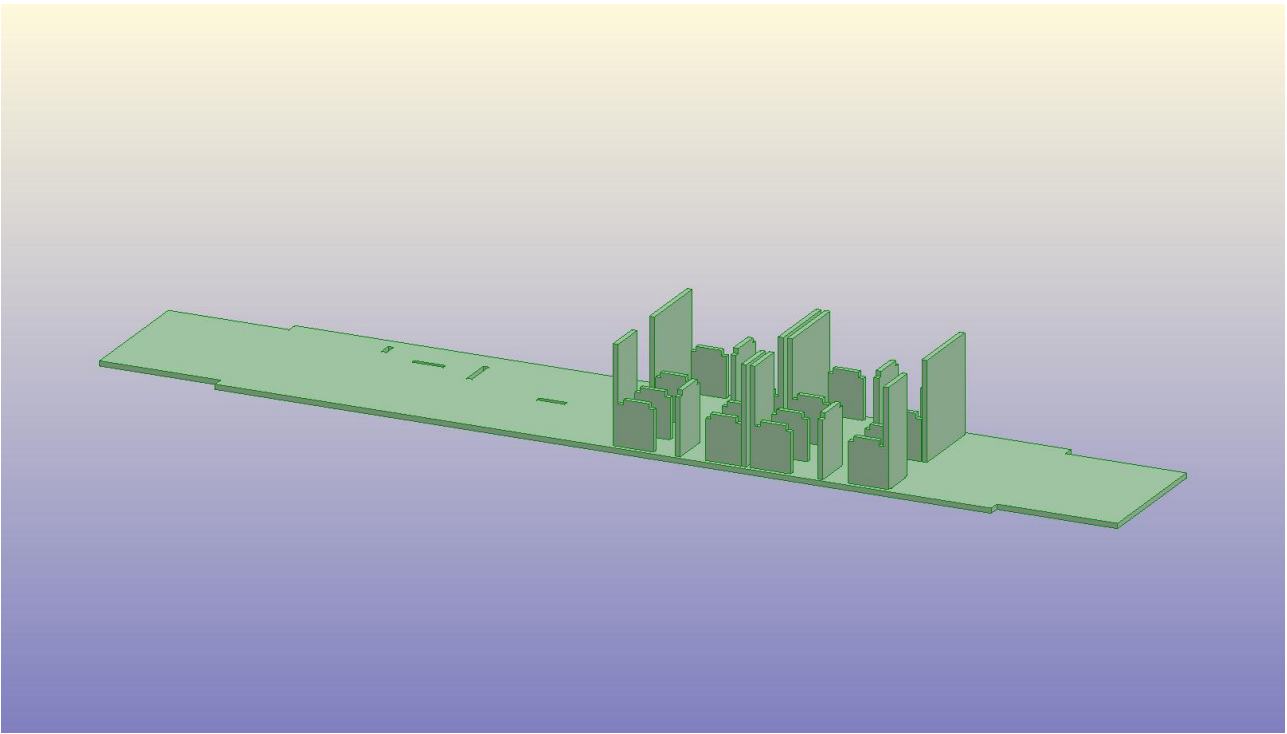

*Next, glue in the table supports. These are the larger of the similarly shaped components (the smaller ones are the seat supports).*

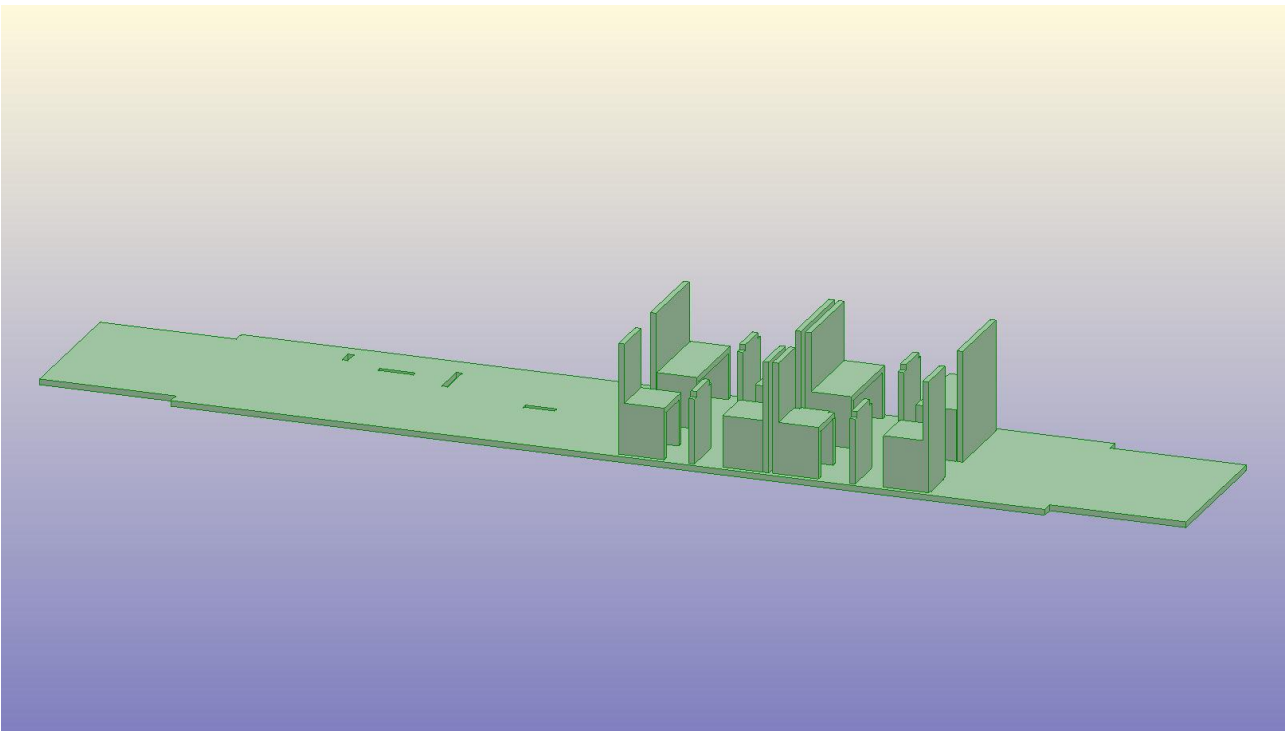

*Now glue the seat tops into place.....*

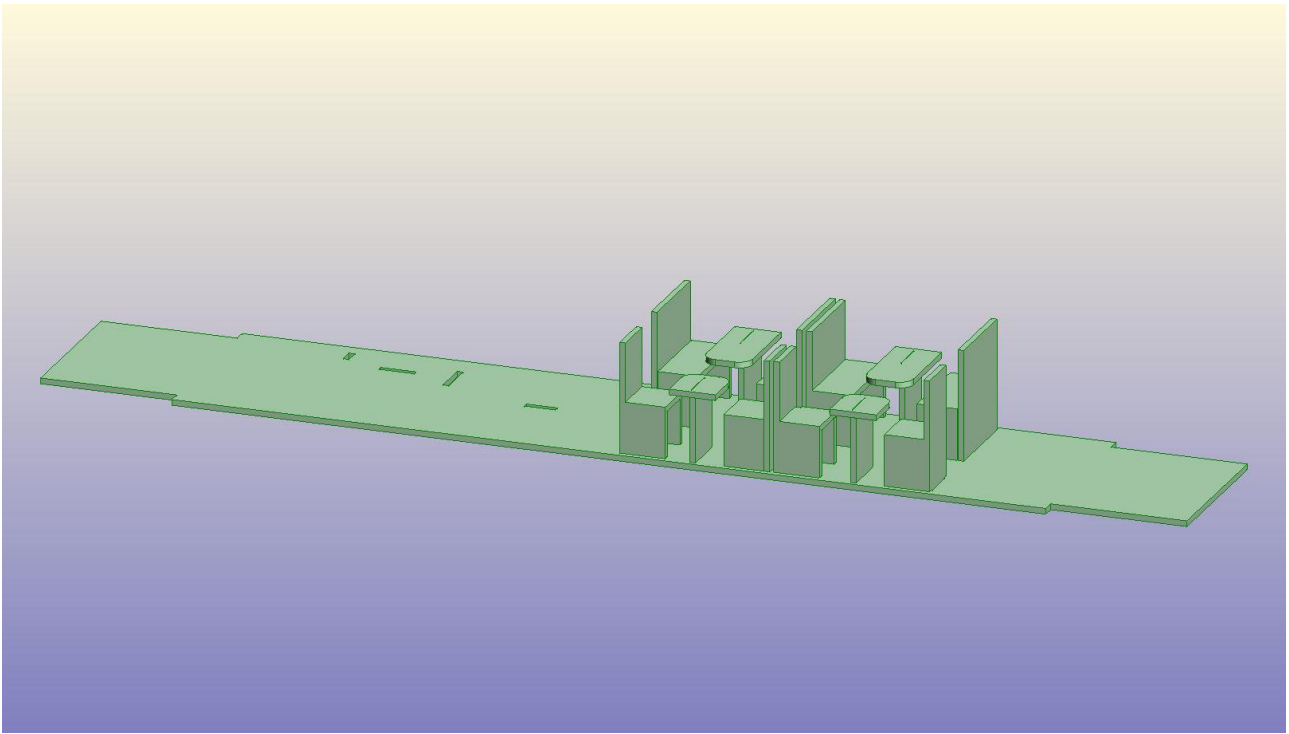

*.....Followed by the table tops.*

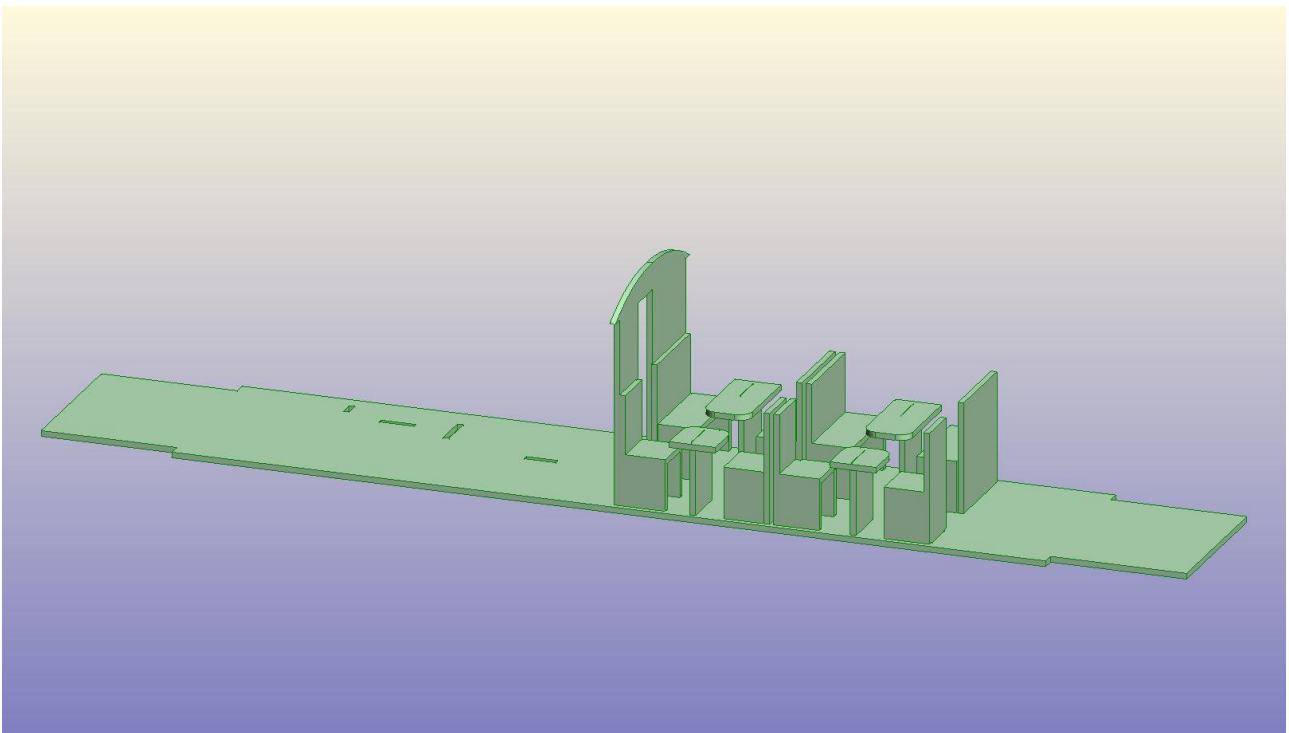

*To complete the interior, glue in the internal partition into place at the end of the seating area.*

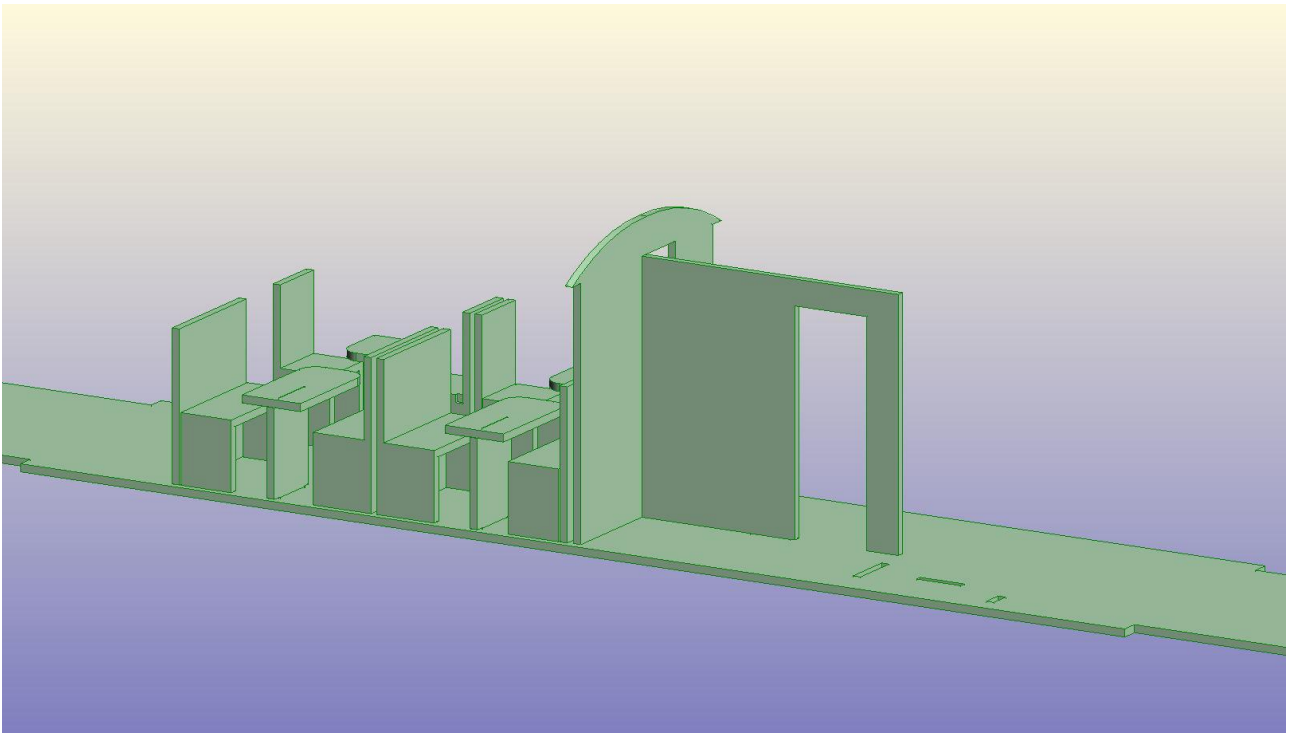

*Next, glue into place the toilet compartment wall.....*

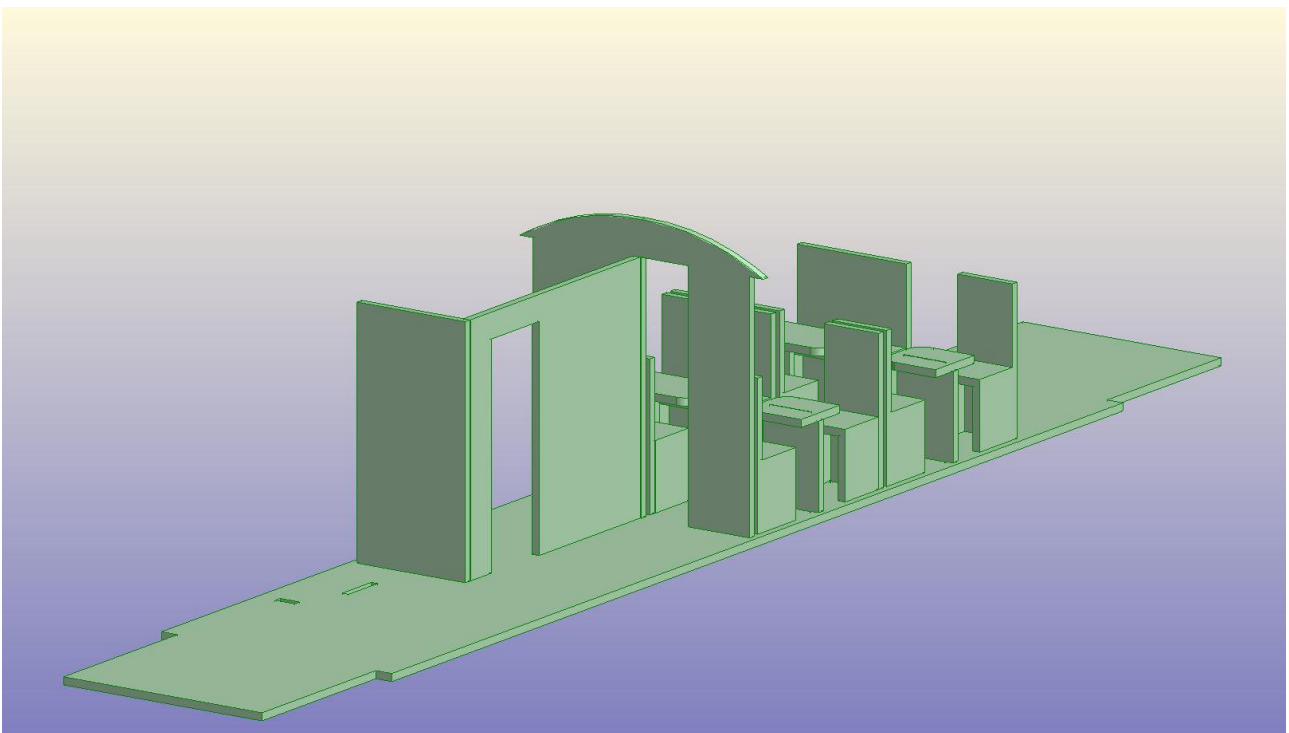

*Then the toilet compartment end partition.*

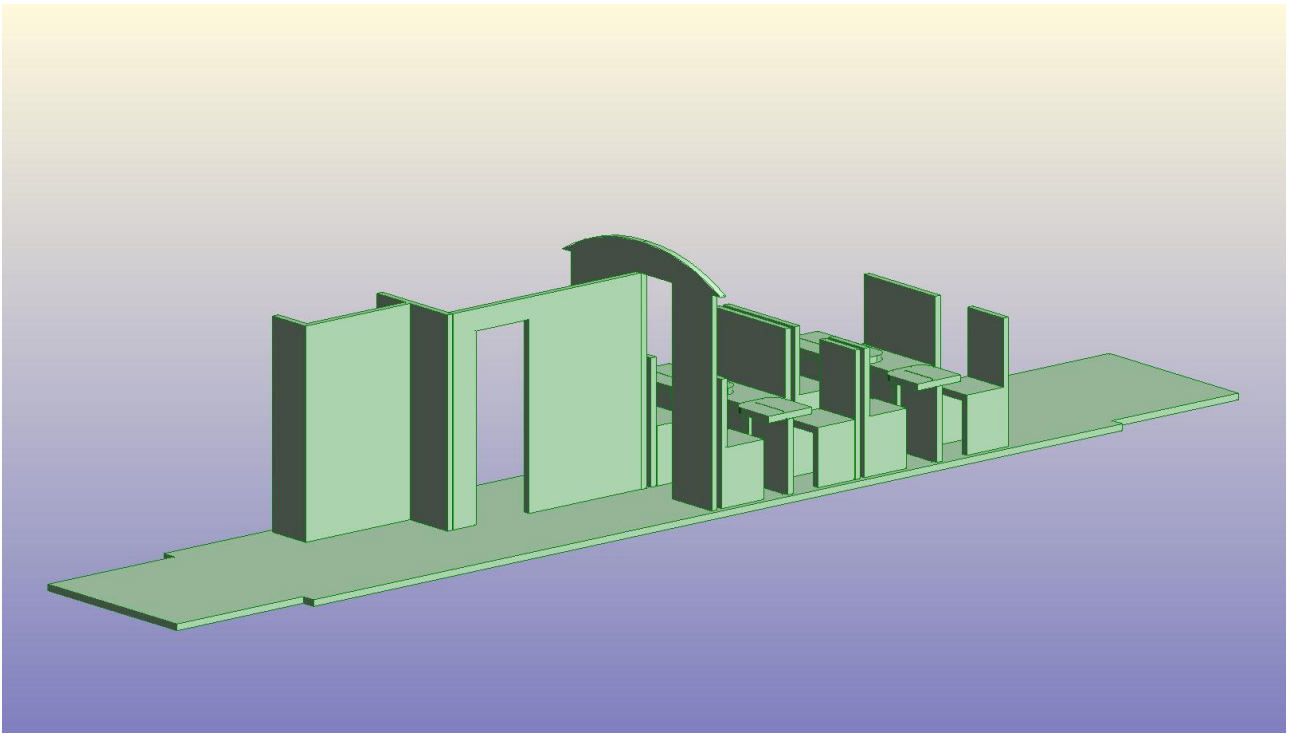

*Now, glue into place the equipment cupboard.*

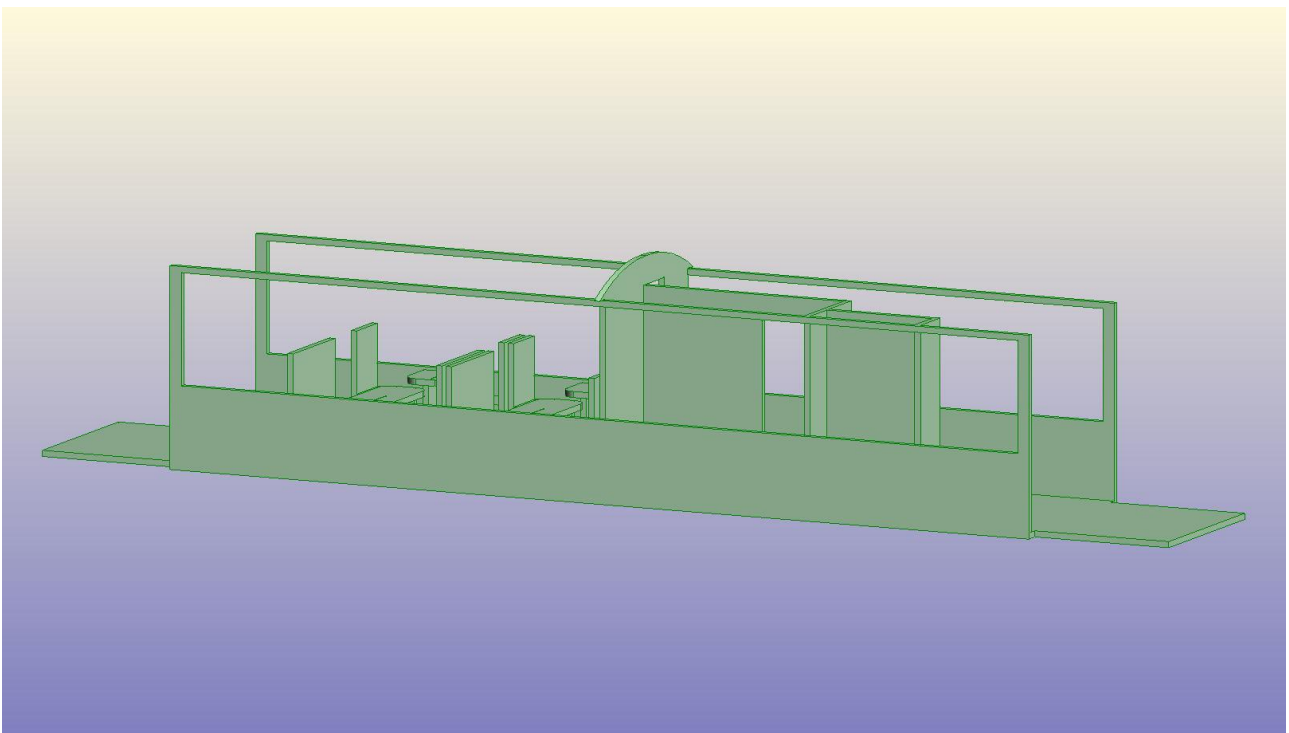

*To start assembling the main body, glue the inner layer of the body side onto the lip between the side of the tables/seats and the edge of the chassis plate. For reference, these are the shorter of the four main body sides.*



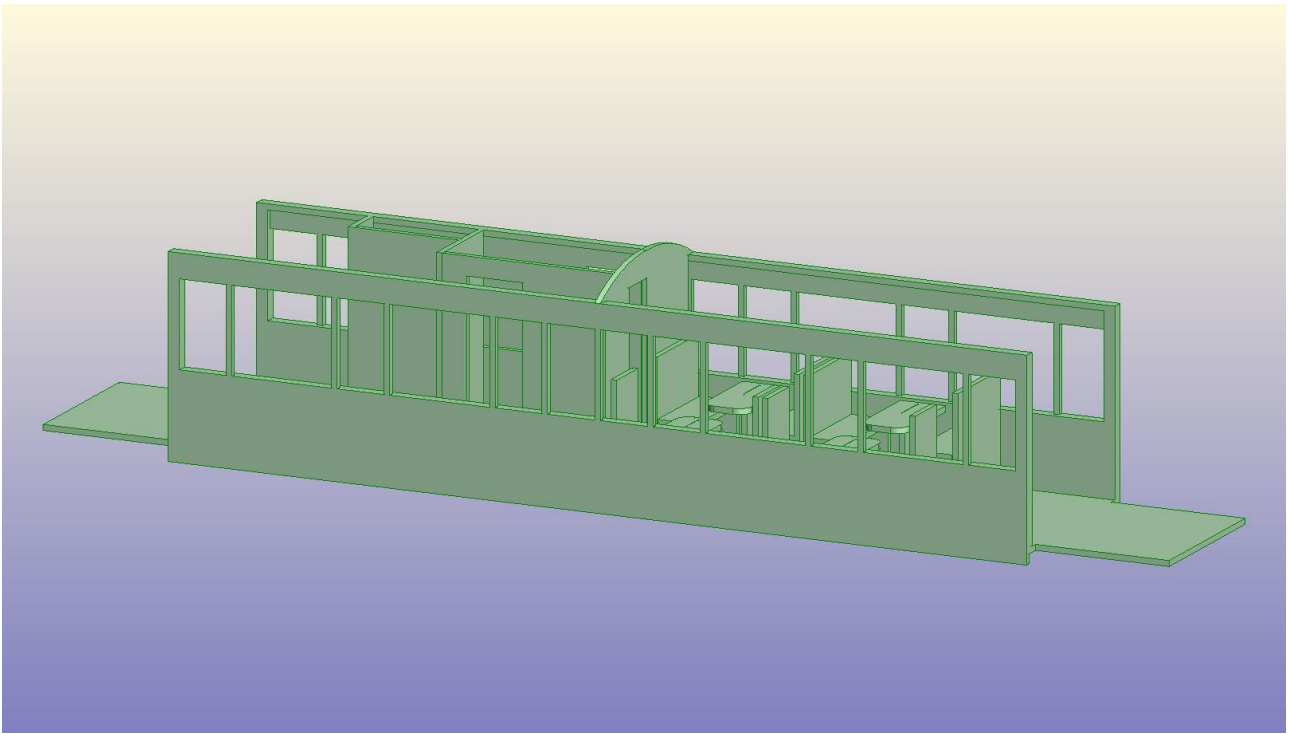

*Then glue over the top, the outer layers. These can also be distinguished by having the etched detail for the beading on them.*

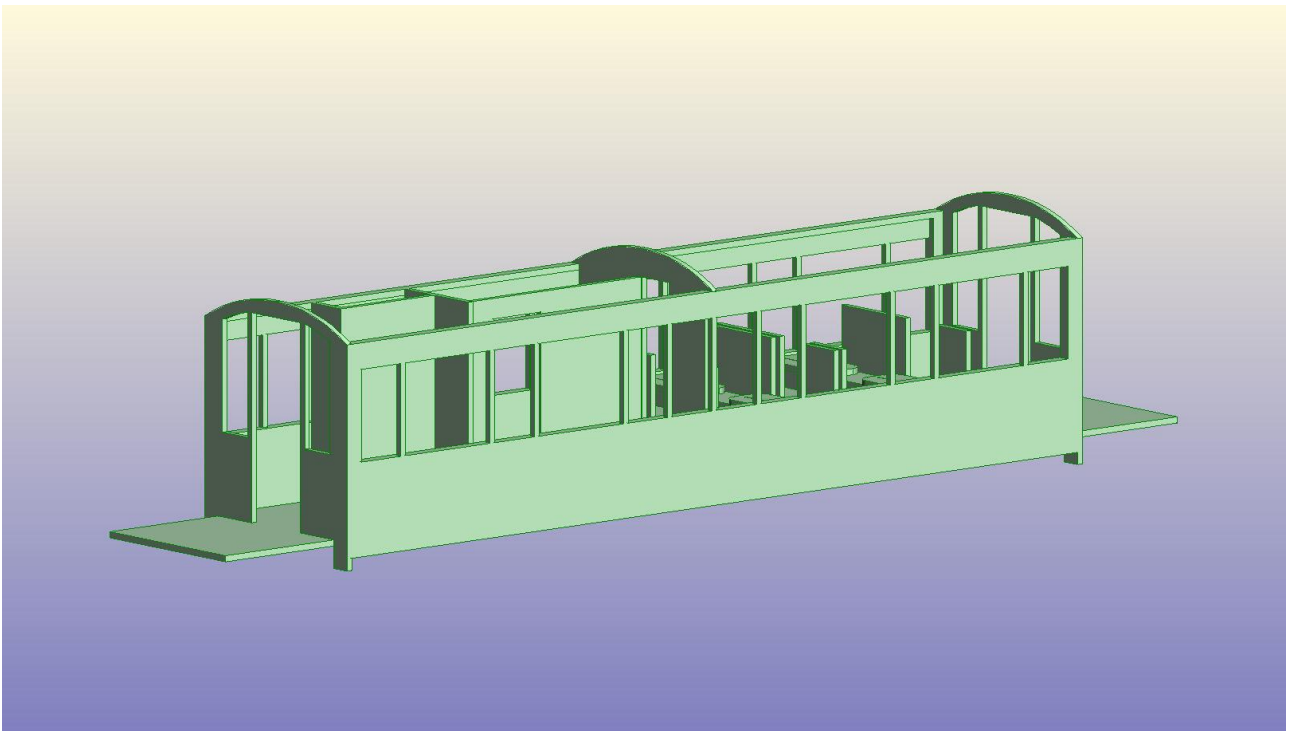

*Now glue into place the passenger compartment end dividers.*

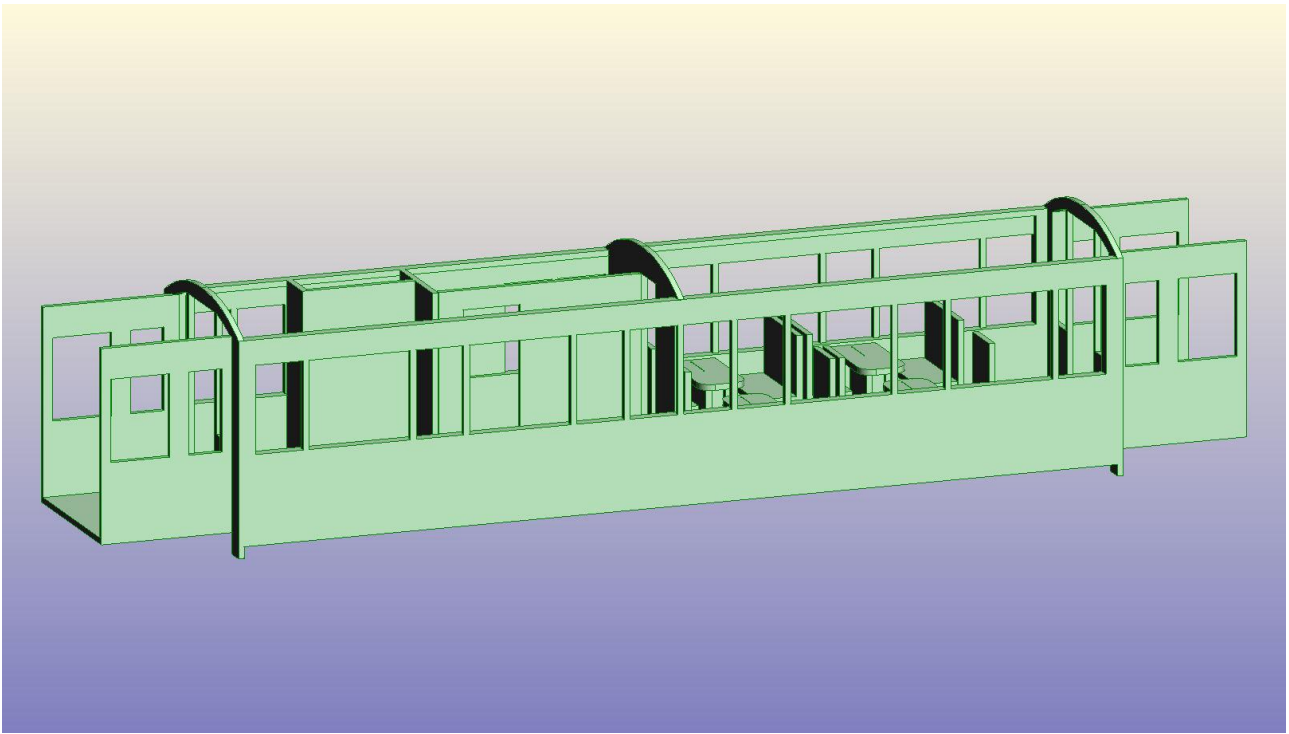

*Next, glue into place the doors. The smaller of which are closest to the passenger compartment.*

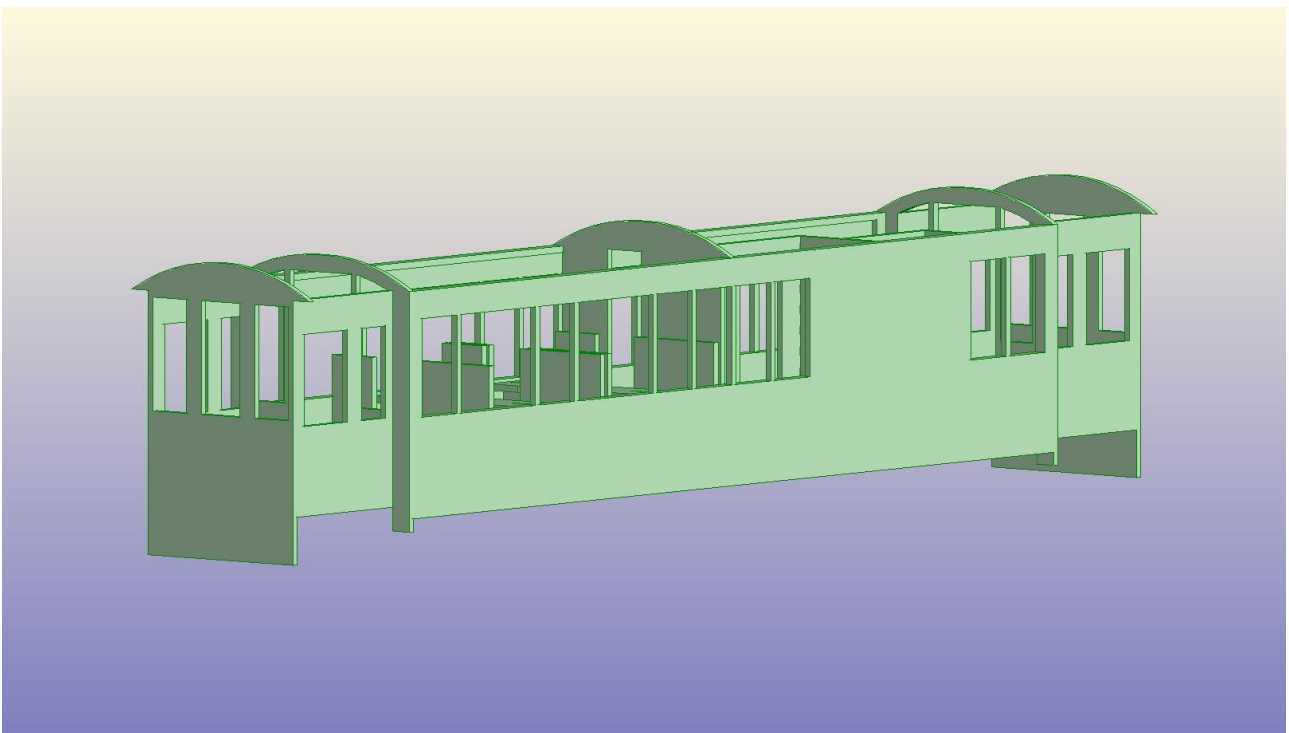

*Now, glue into place the coach ends.*

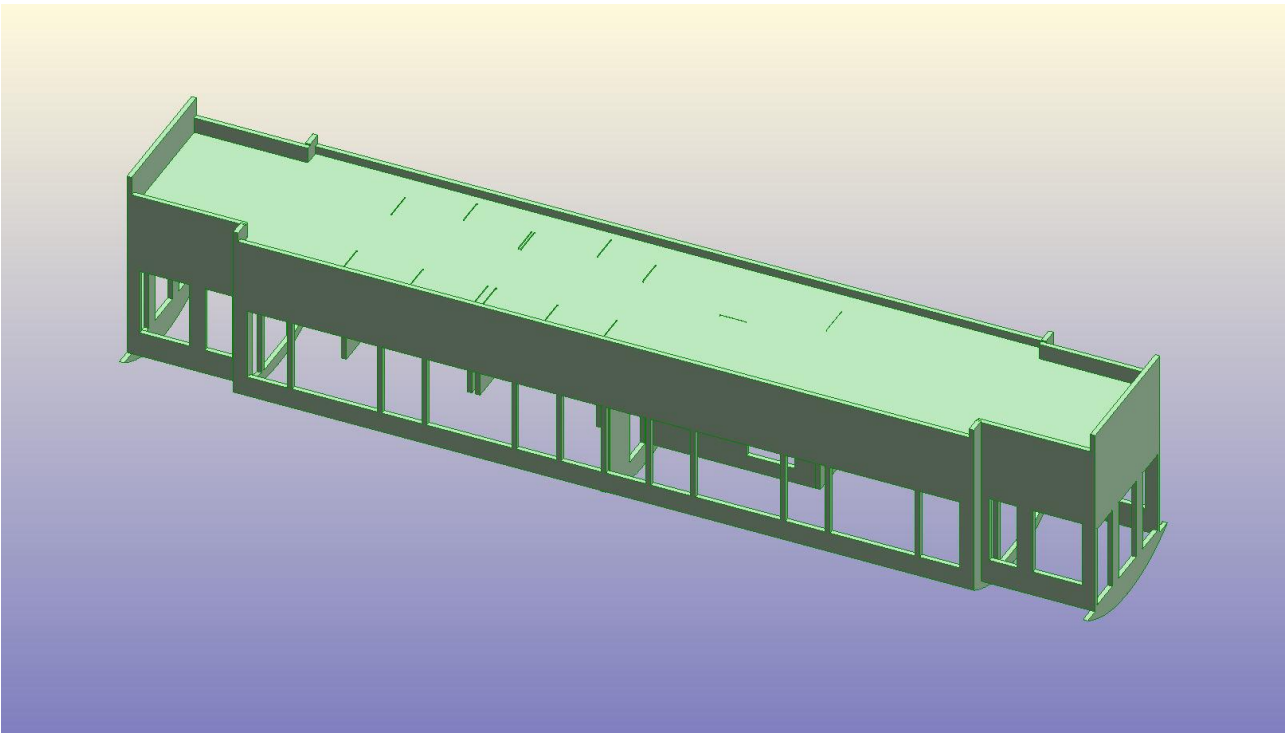

*Now time to install the steps. These sit just inside of the doors underneath the chassis plate.....*

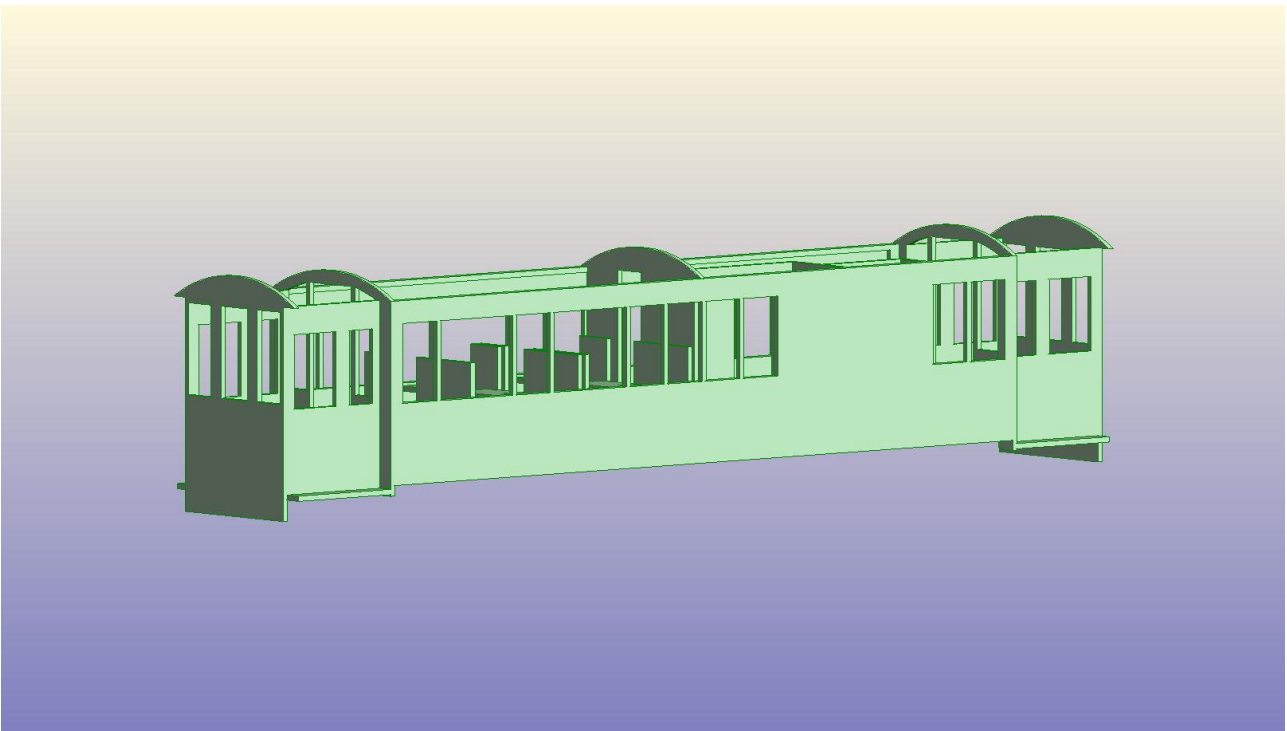

*.....followed by the steps themselves which form a small shelf in each corner of the model.*

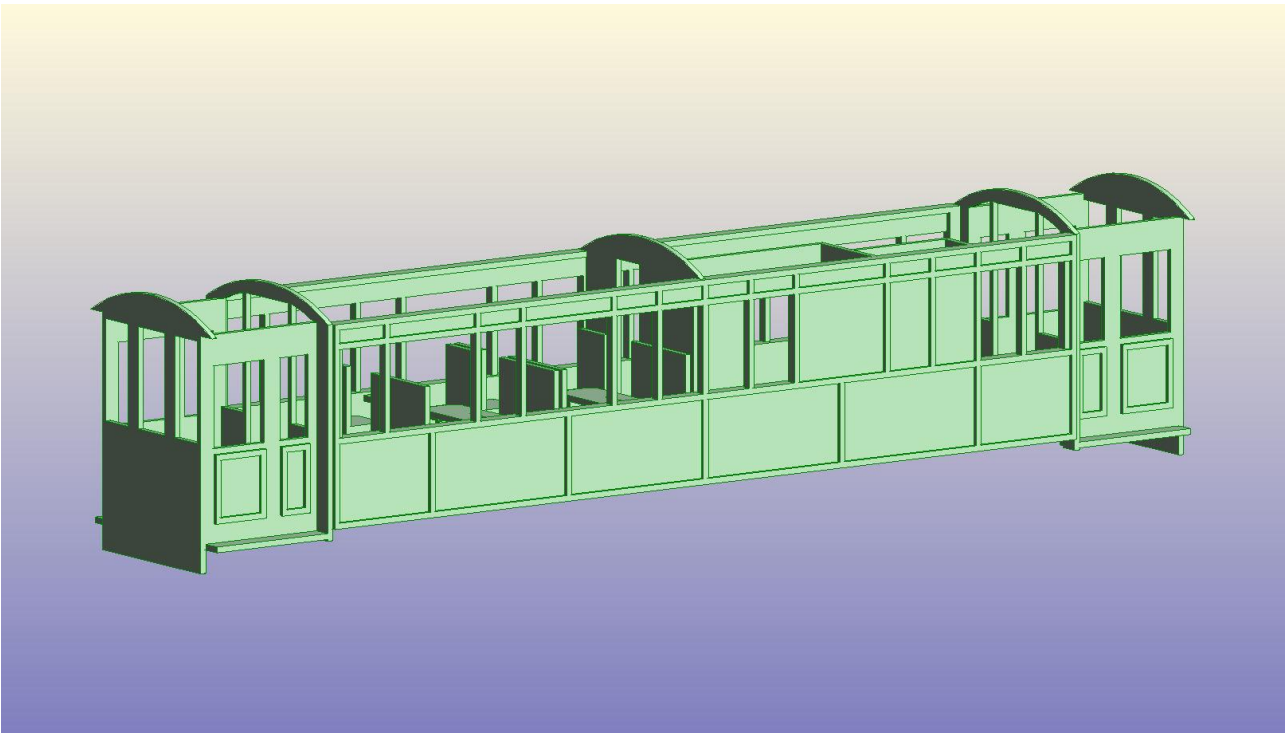

*Now its time to glue on the beading. To aid you, there is etched markings on the sides and ends of the coach to show you where they go. Note, each side is different to each other.*

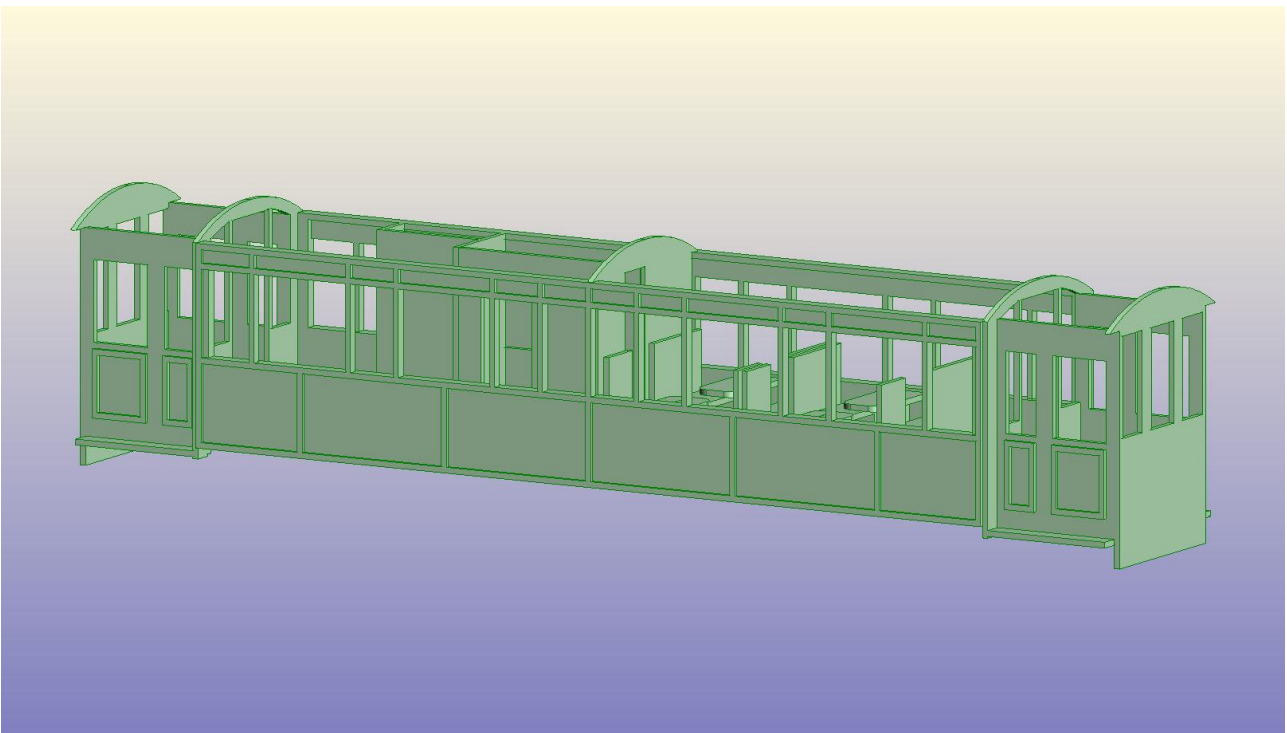

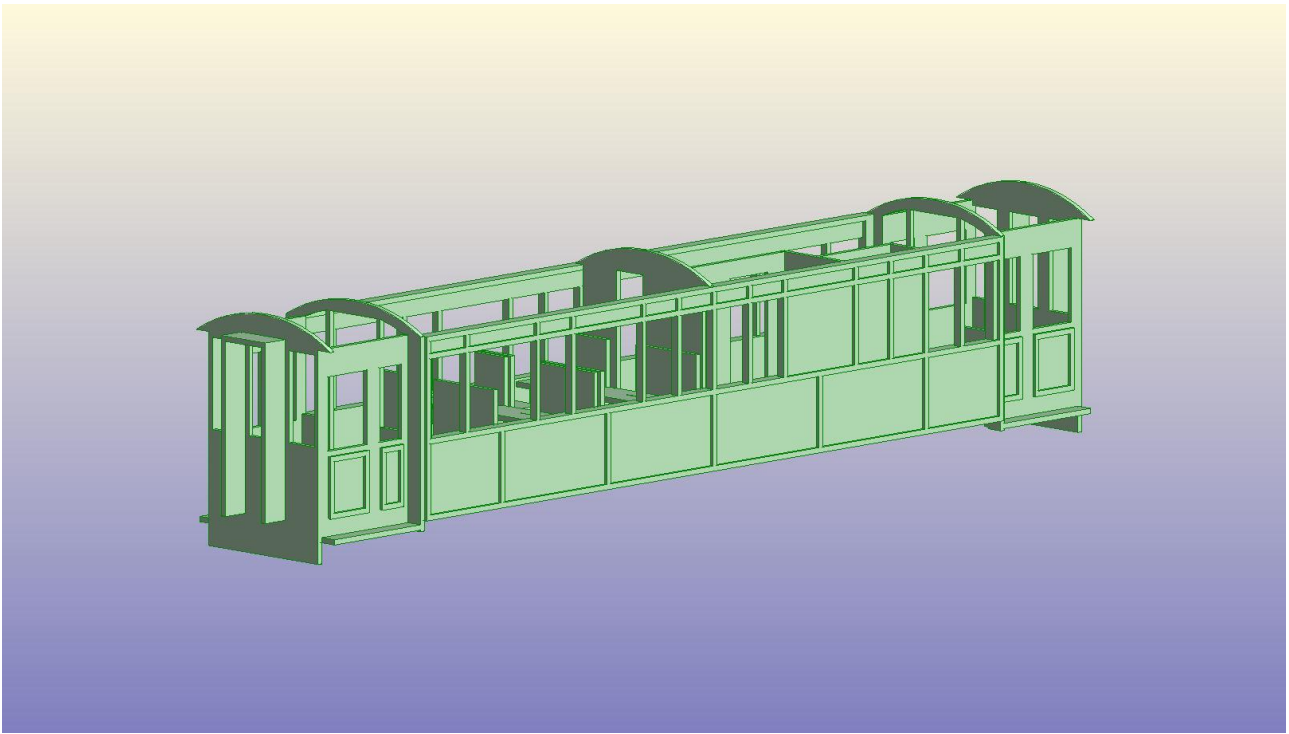

*Next, glue in the Corridor Connectors again using the etched marks on the coach end as a guide.*

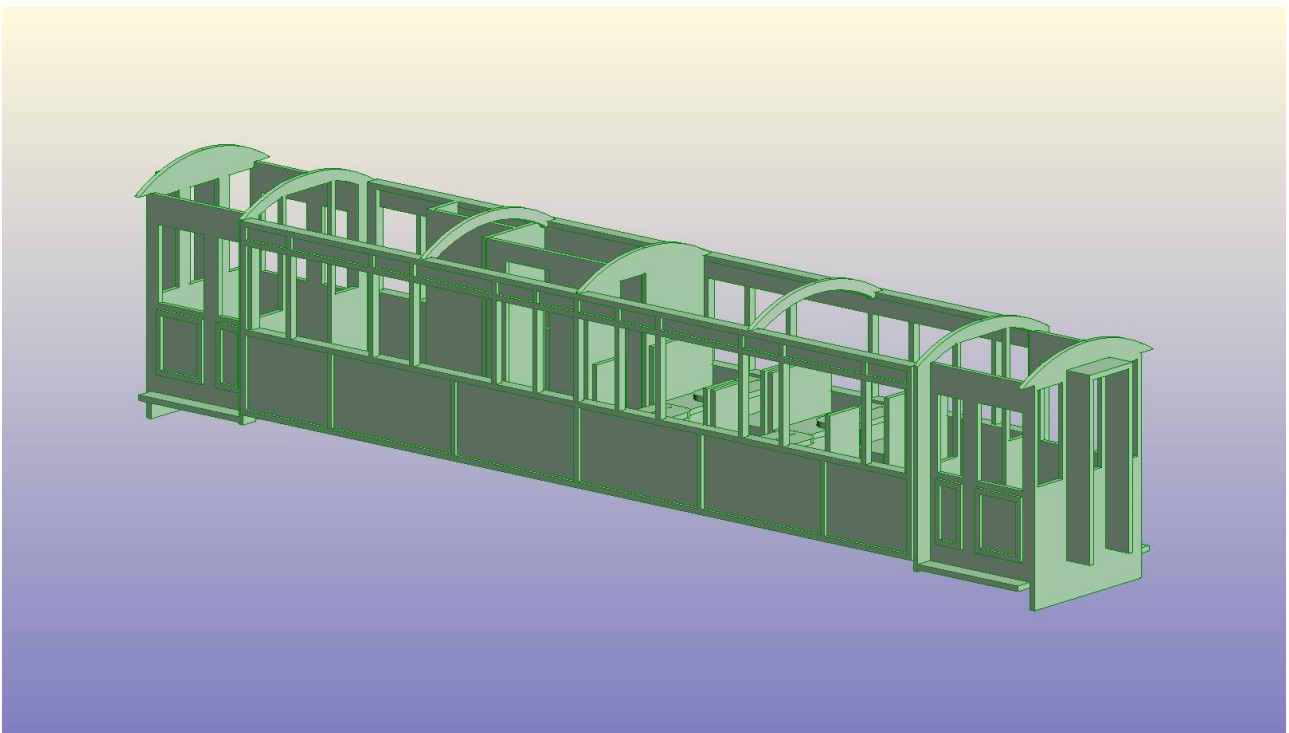

*Before installing the roof, a small number of roof supports need to be glued into place. Where you place these is your choice but we recommend placing them equally along the roof*

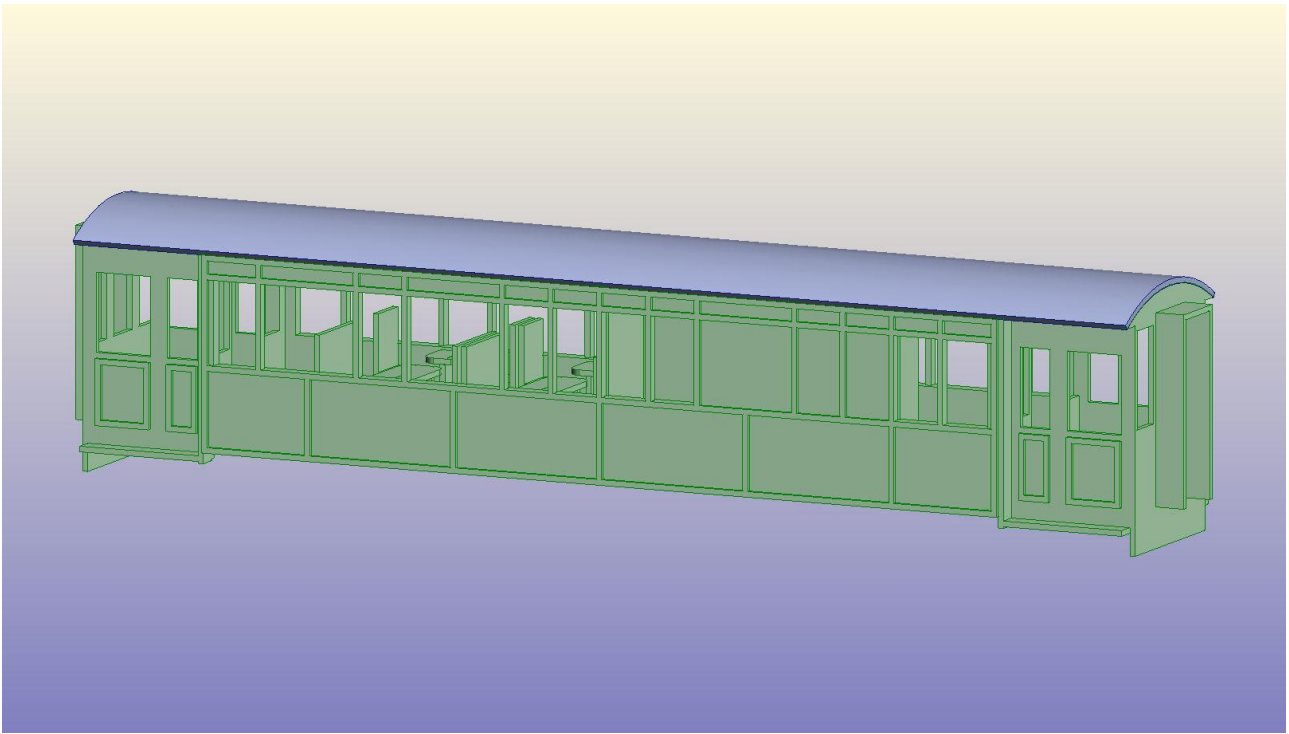

*The roof itself is formed of long thin planks of wood which overlap the ends of the coach to cover the entire coach including beading. To cover the roof, we recommend either craft paper, a old shirt/sheet or masking tape all of which once painted give the perfect effect of canvas as well as smoothening the roof's curve.*

*To complete your model, glue the couplings onto the end of the coach at your preferred height and mount the bogies using the mounts provided. We recommend placing them 90mm from the end of your coach.*

*Your kit is now complete.*



We hope you enjoy your Bowaters Models kit! If you have any questions, don't hesitate to contact us on [info@bowatersmodels.co.uk](mailto:info@bowatersmodels.co.uk)

We thank you for your custom.