

Bowaters MODELS

specialising in distinctive 16mm models

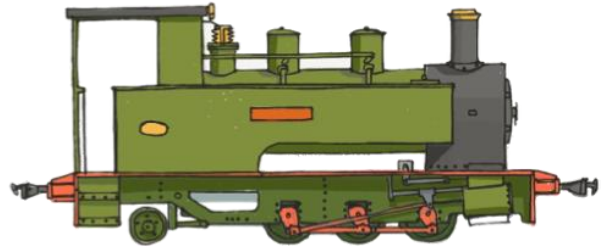

Bowaters Models – BMF Series Instructions Service Car (124/125)



Requires

- Accucraft Chopper Couplings (Z1 or Z2)
- Bowaters Models FR Modern Coach Bogies (Own Choice of Gauge)
- 2-3 A3 pieces of Craft paper
- Glazing Material

Required Tools

- Fine Sandpaper/Emery paper or boards
- Small Files
- PVA Glue
- Super Glue
- Sharp Craft Knife

Prototype Information

During the early 1960s, the Ffestiniog Railway management decided that the current fleet of existing Passenger Stock was inadequate for the constantly growing passenger loads the railway was transporting on a regular basis. To carry these passengers, a new design of coach was drawn up with noticeably more headroom than the existing stock, along with other improvements. The new coaches were built with wooden bodies on steel under frames. The initial set of 6 coaches were built using the profile of the recently rebuilt former L&B Coach No.14 and quickly gained the nickname 'Barns' as a result. Over time, 2 of the first 6 have been scrapped while 4 newer builds have joined the fleet giving a current operational fleet of 8 'Barns'.

Current Operational Fleet:- 100, 102, 104, 105, 106, 107, 123, 124

In the early 1990s, as part of the INCA Programme, the FR built a set of 3 similarly designed coaches to boost the operational fleet. All 3 were fitted with push pull equipment and featured aluminium bodies running on steel under frames. These coaches quickly became known as 'Carnforths', after the company that completed the majority of the construction work. All 3 remain in service on the present day Railway.

Current Operational Fleet:- 112, 113, 114

About the Kit

The kit is a wooden kit comprising of a set of laser cut wooden parts. If you have a Observation coach or Tin Car kit, you will also have 3D printed section(s) for part of the roof.

Chassis Fitting

This kit is designed for Bowaters Models FR Modern Bogies. These are assembled as per the instructions with no modifications required. On the top chassis piece, normally distinguishable by the laser cut detailing on the top surface, flip it over so the detailing is facing down. Then draw a straight line down the centre of the piece lengthways. This is needed so that once the chassis has been assembled, the correct position of the bogies can be achieved. They should normally be added once the chassis has been assembled and should be placed 90mm along the line from each end of the coach. Alternatively, you can attach the bogies closer to the end of the coach to dramatically reduce the minimum radius.

Couplings

This kit is designed to take Accucraft Chopper Couplings (available separately as their part number Z1/Z2). These should be attached into the flat sections below the main coach bodies. These have been positioned so as to be at the correct height for the 16mm Association standard coupling height. We strongly recommend setting the coupling height against your existing motive power fleet.

Instruction notes

With these instructions, there are images which show various stages of the construction of the Buffet Coach kits. They are of the Digital Builds for Coach 103 which may not be representative of the kit you have brought. They are for reference purposes only.

Painting

Over the time period the coaches we have produced have operated, they carried various paint schemes.

- 1958 to 196? Varnished Wood
- 196? - 198? - All over Maroon (Closest match is Humbrol 20 (Crimson Gloss))
- Push Pull Paint Scheme of Cream and Green (Closest matches are Humbrol 41 (Ivory) and Revell 364 (Leaf Green)) for coaches 117, 121 and 112 to 114
- 199? - Present - Modern FR Coach Paint Scheme of Cream and Maroon (Closest matches are Humbrol 20 (Crimson Gloss) and 41 (Ivory))

Beading Notes

These instructions cover the latest generation of kits produced after March 2019. These can be told apart from the earlier kits by having one piece beading sets for the sides and ends.

Please Turn over

Please read though these instructions before beginning to assemble your
kit

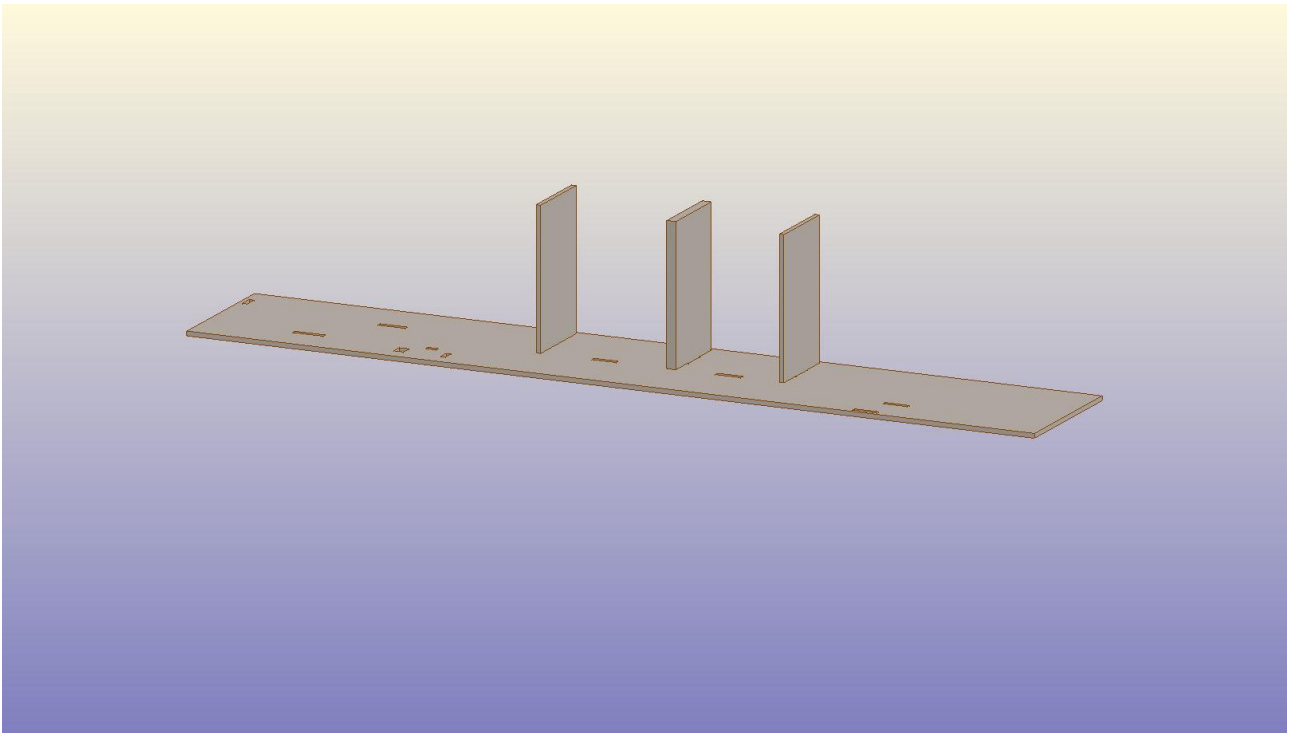

Start by gluing the centre Compartment partitions into place.

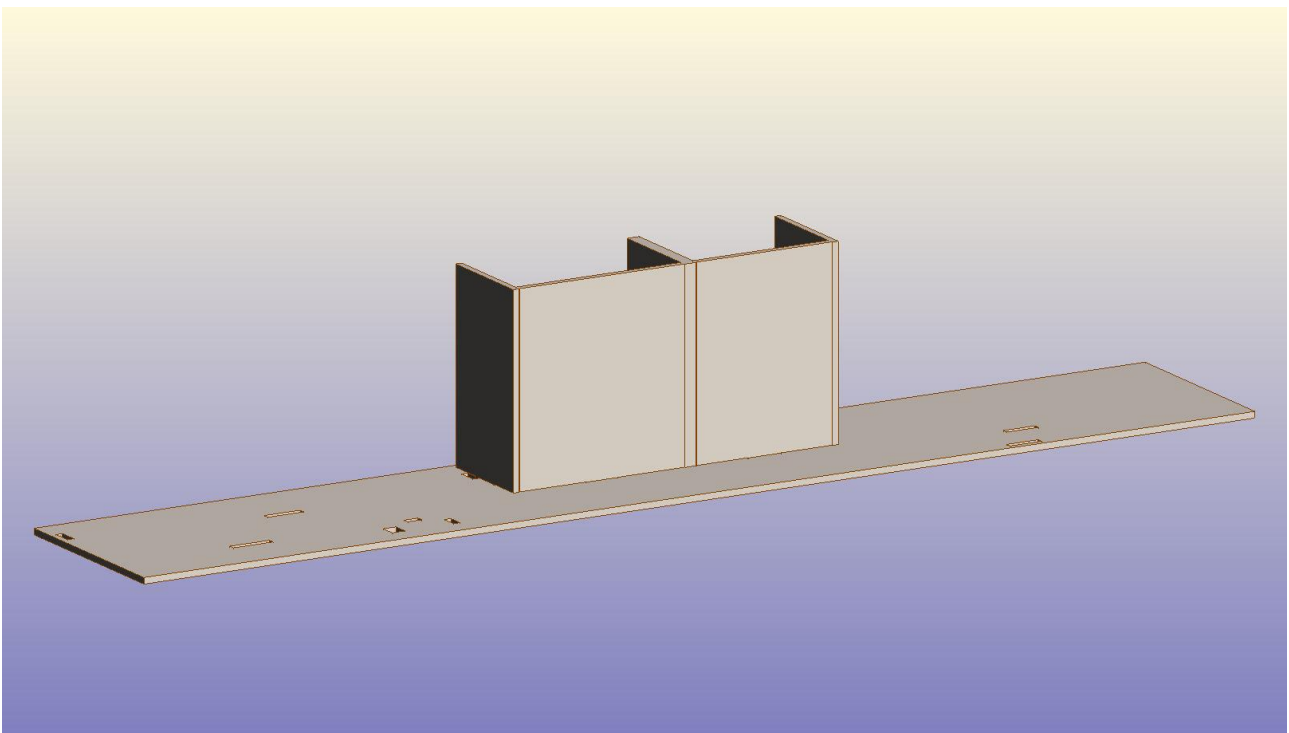

Next, glue in the compartment centres.

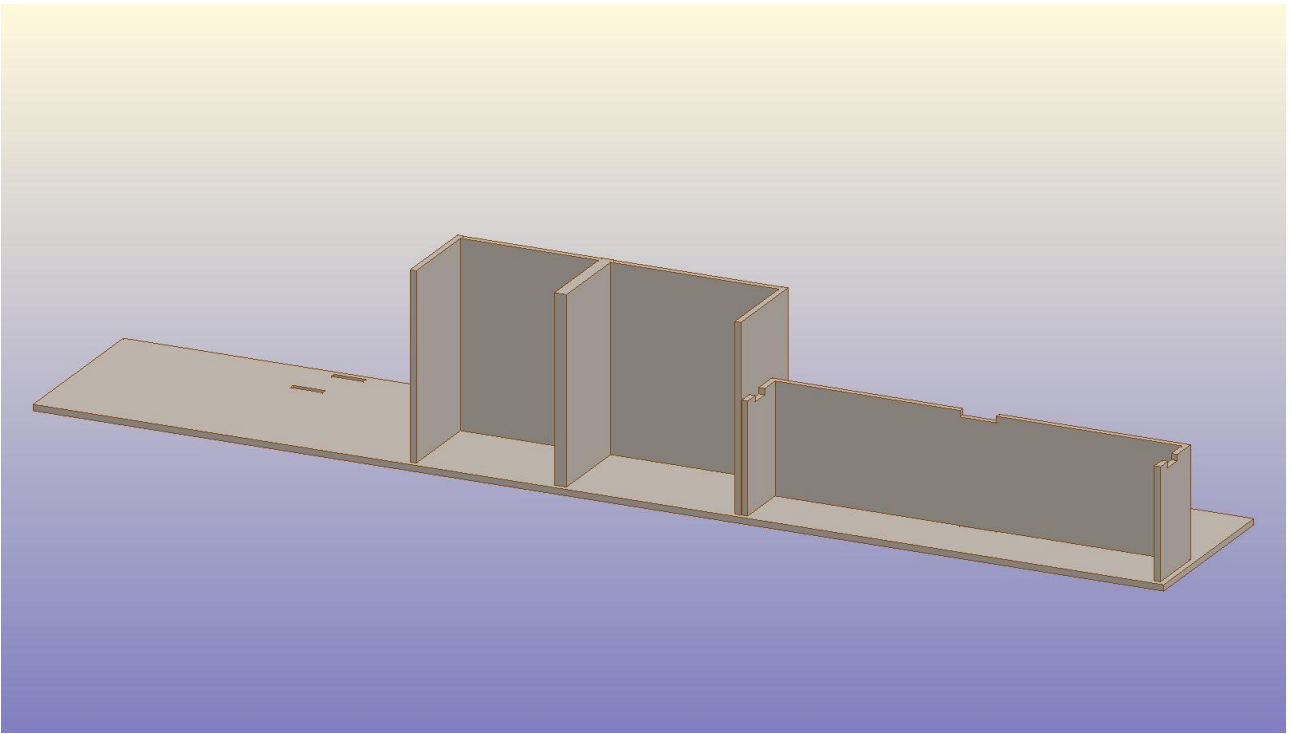

Next, start on the long counter by gluing the uprights into place making sure you get the tabs the correct way round for the top. If in doubt, do a dry run to ensure it will all slot together correctly.

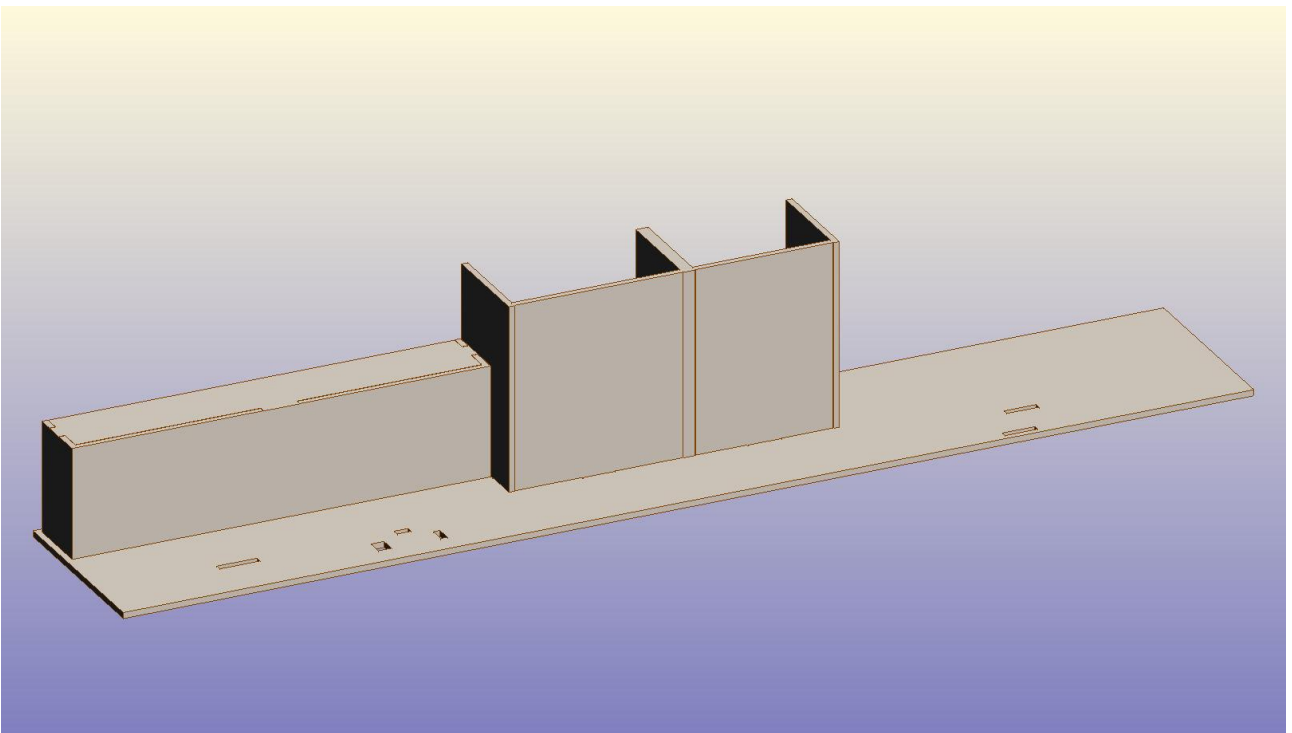

Now Glue in the counter top.

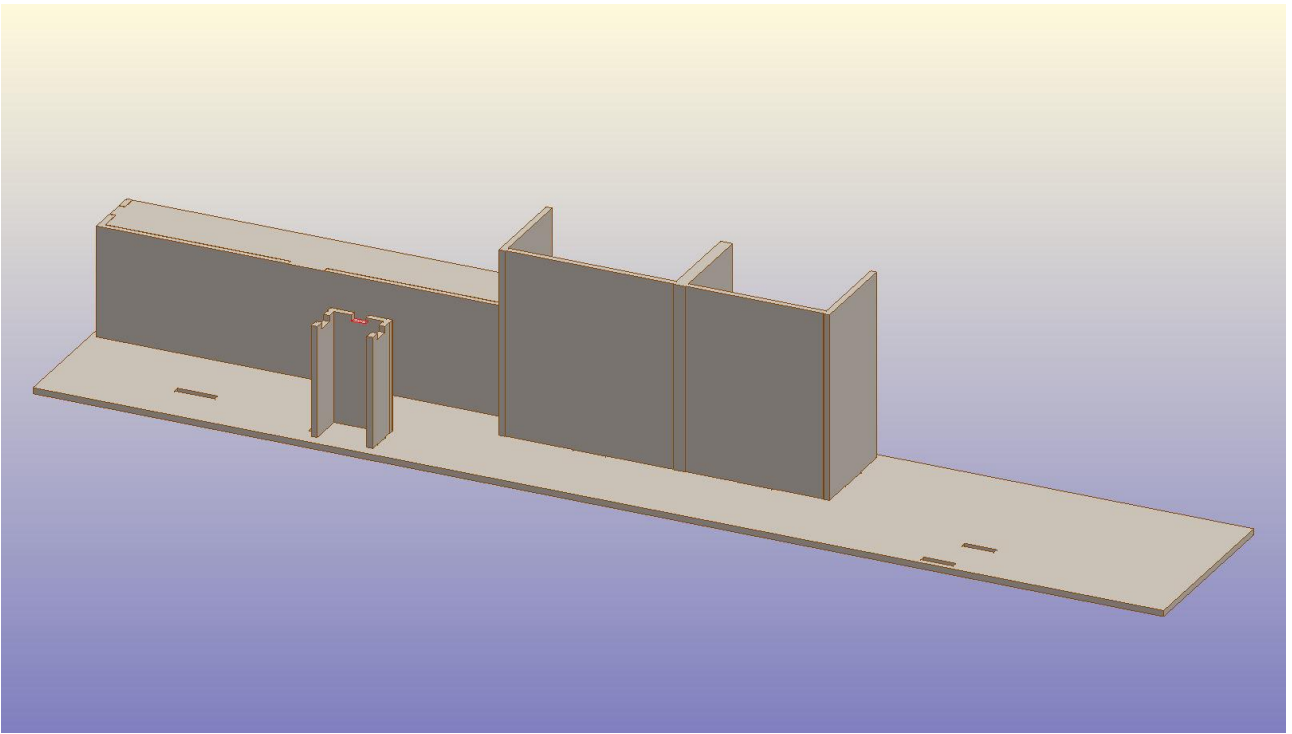

Next, start on the small counter by gluing the uprights into place making sure you get the tabs the correct way round for the top. If in doubt, do a dry run to ensure it will all slot together correctly.

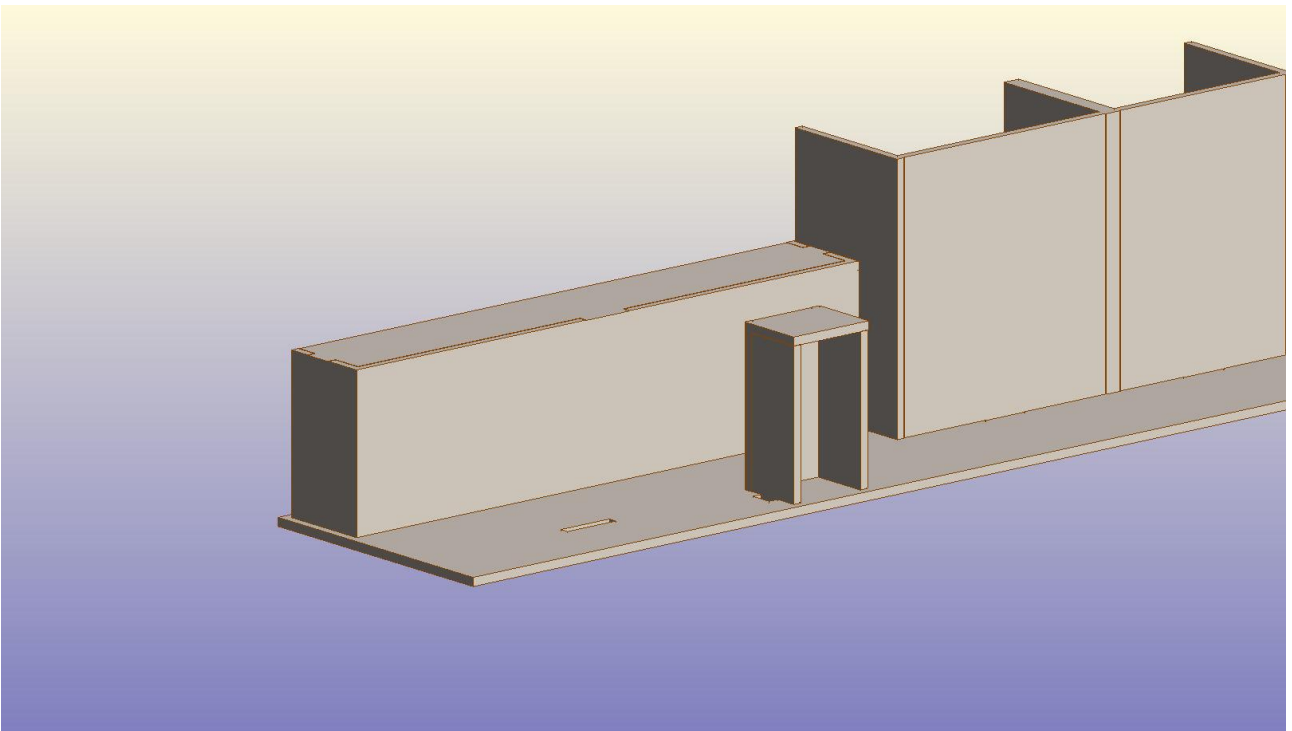

Now Glue in the counter top.

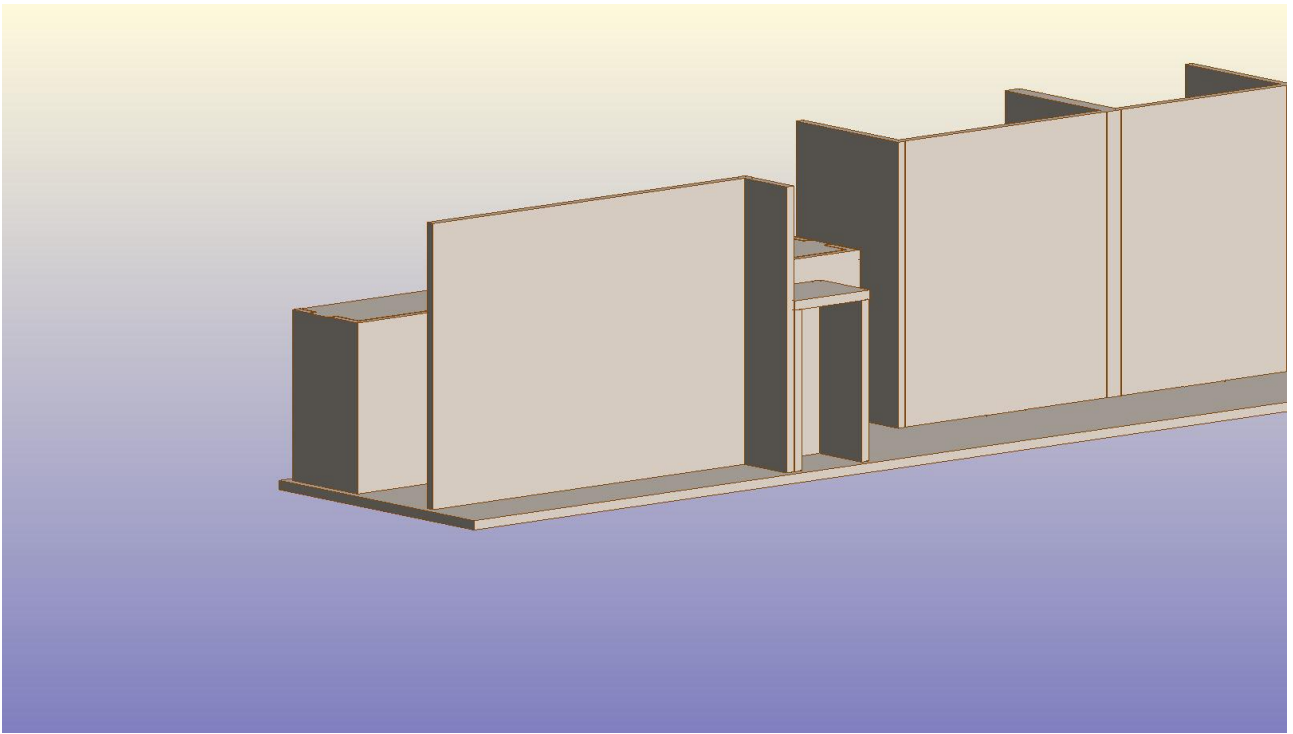

Next, glue in the kitchen cupboard pieces into their slots in the floor.

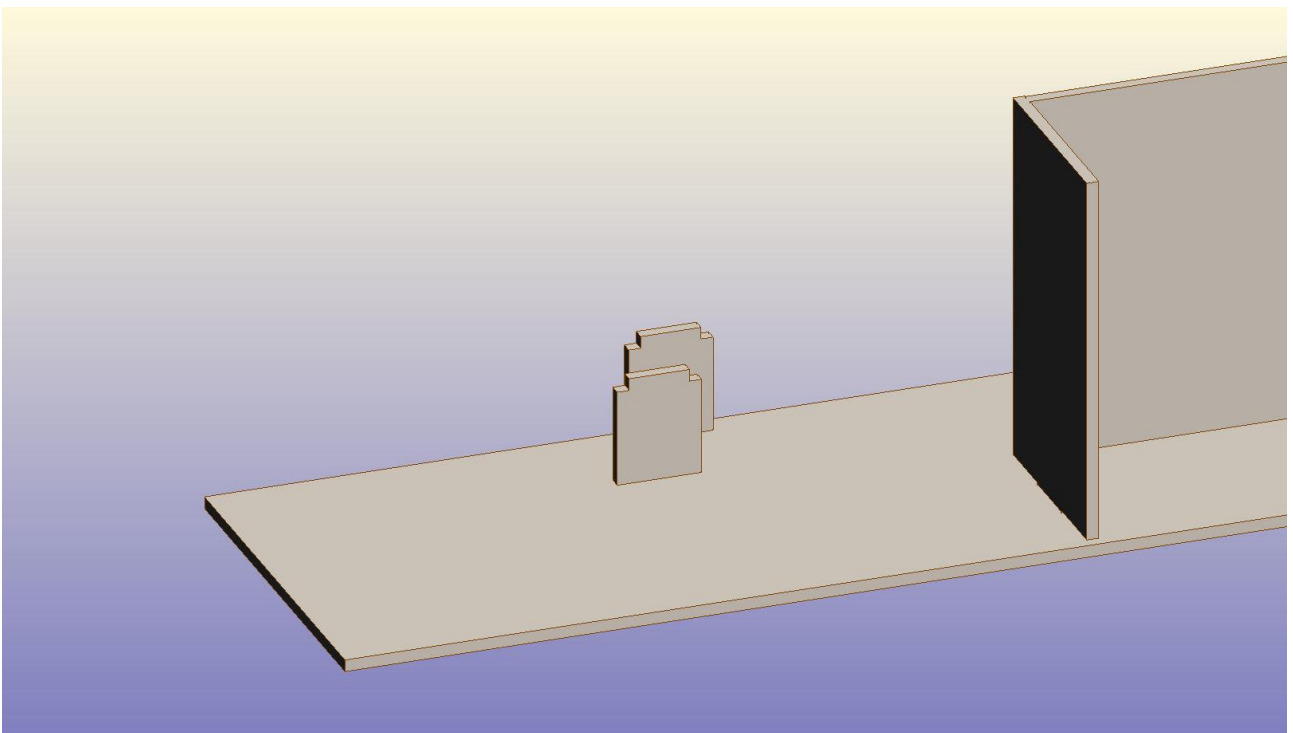

Now, start on the seat by gluing the uprights into place.

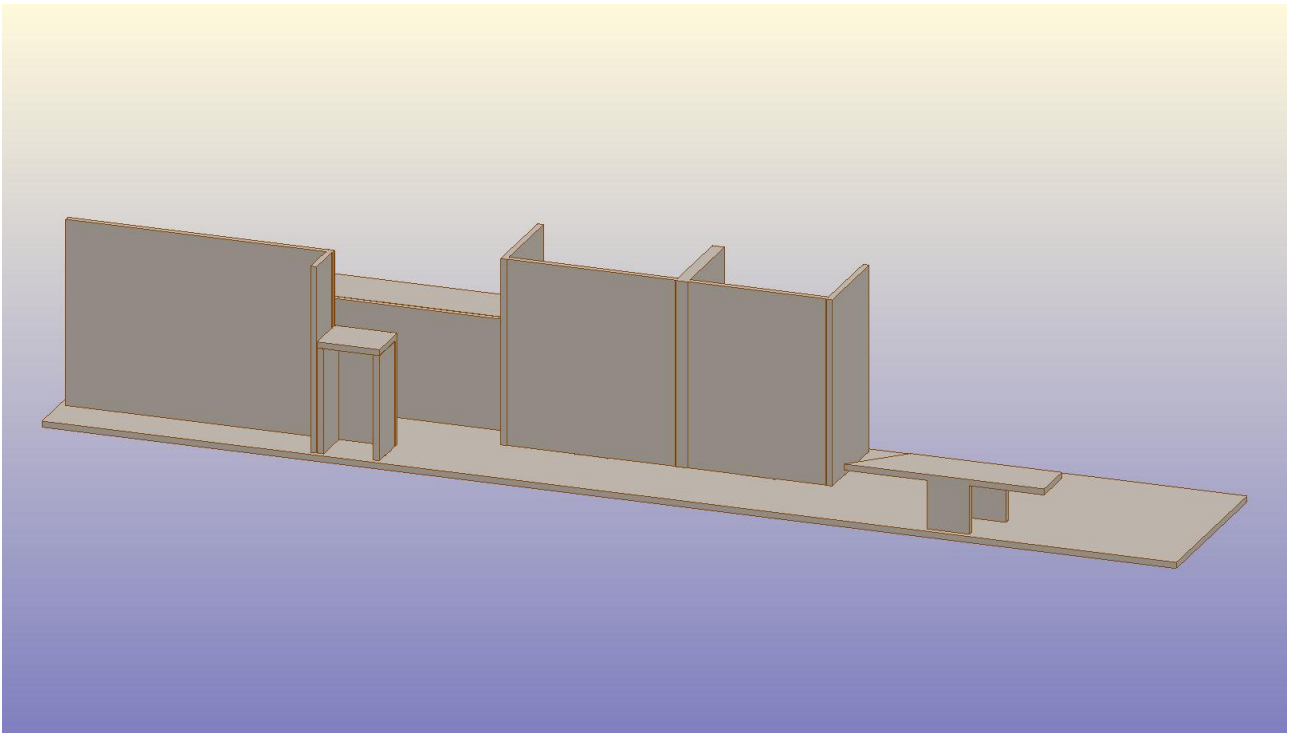

To complete the interior, glue the seat into place.

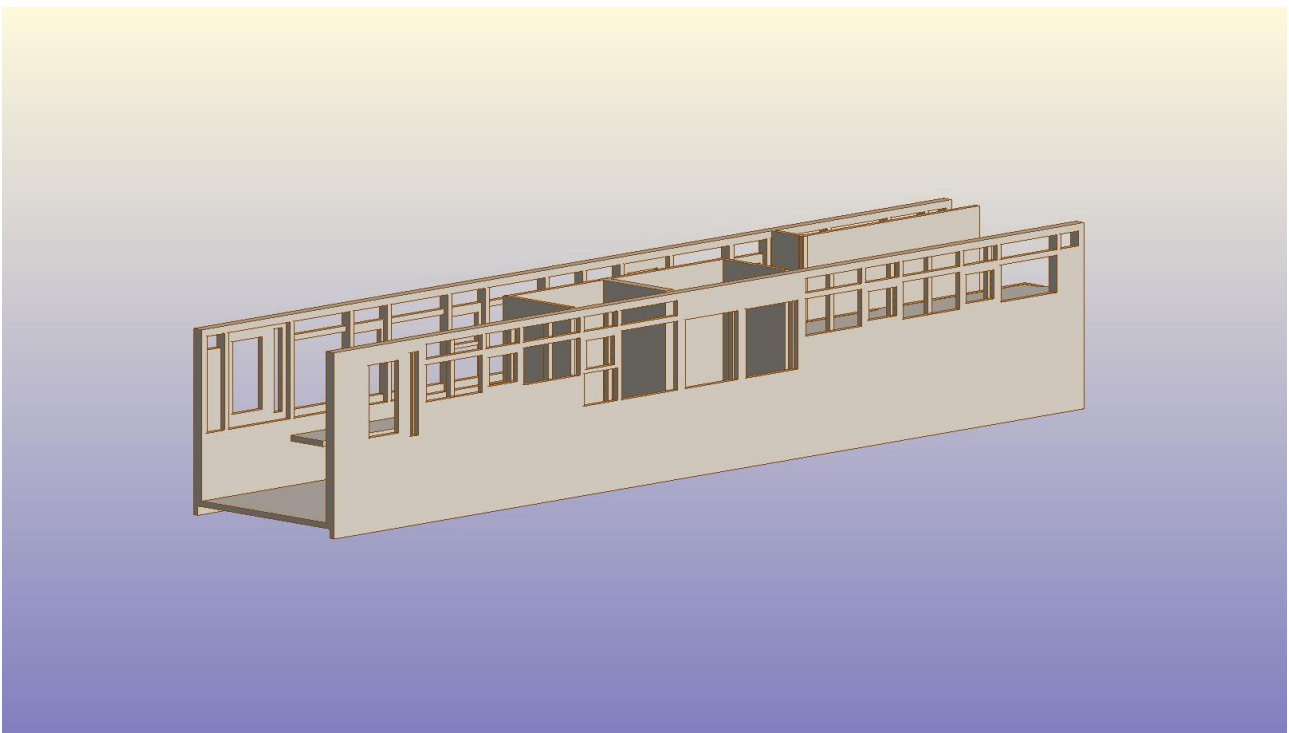

To start assembling the main body, glue the inner layer of the body side onto the lip between the side of the tables/seats and the edge of the chassis plate. For reference, these are the shorter of the four main body sides.

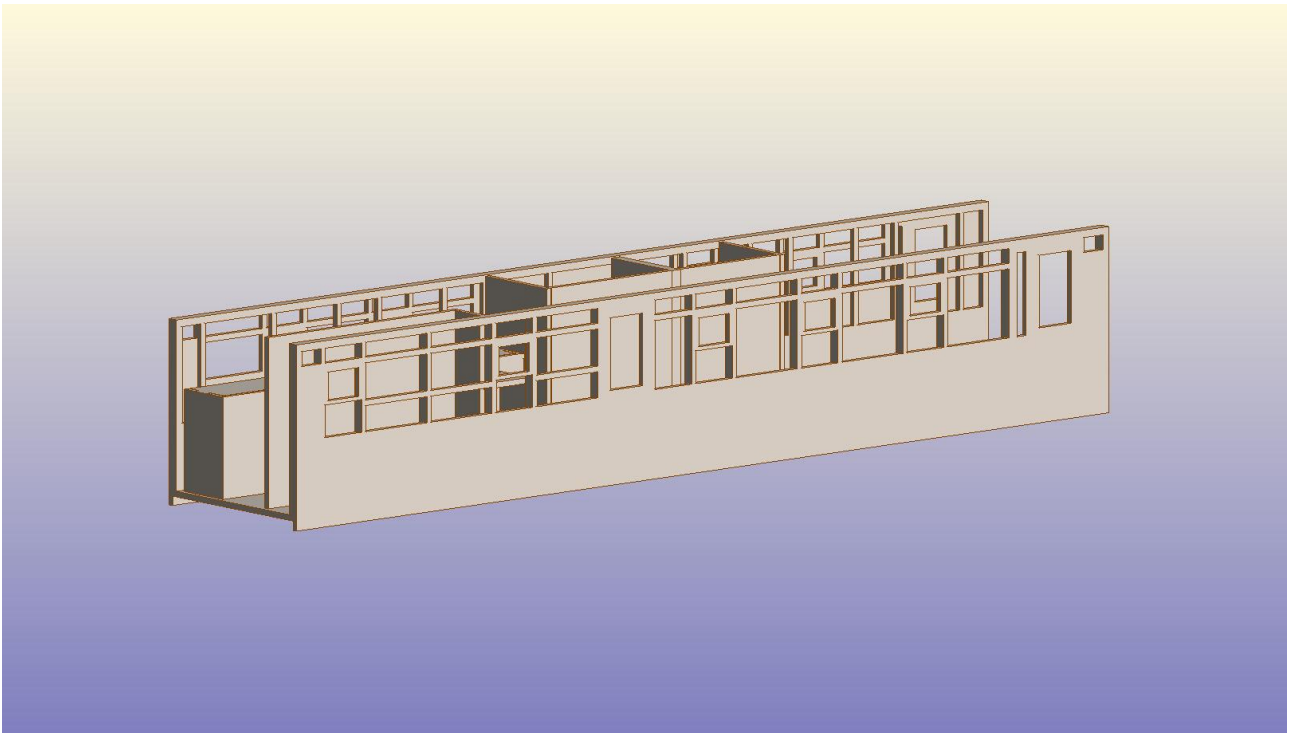

Then glue over the top, the outer layers. These can also be distinguished by having the etched detail for the beading on them.

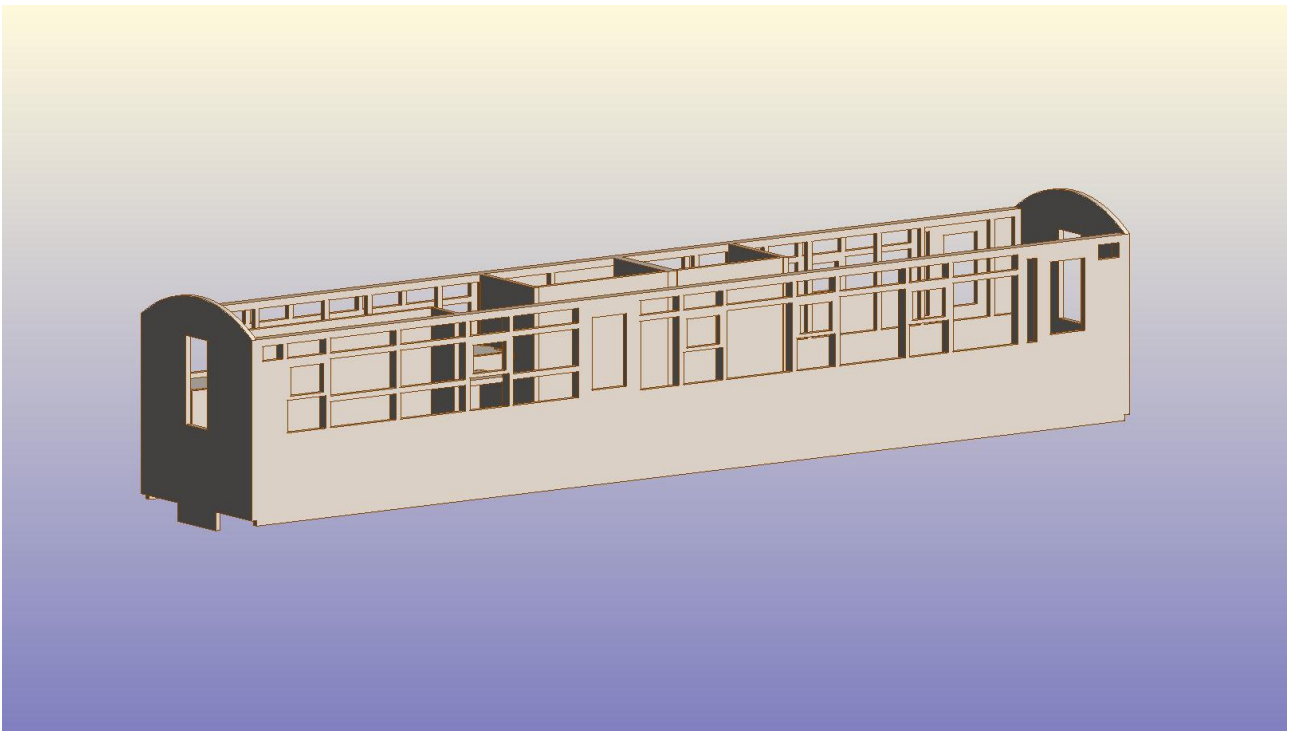

Now, glue on the ends of the coach. These sit on the very ends of the models and the top left/right hand corners will line up with the corners on the body sides.

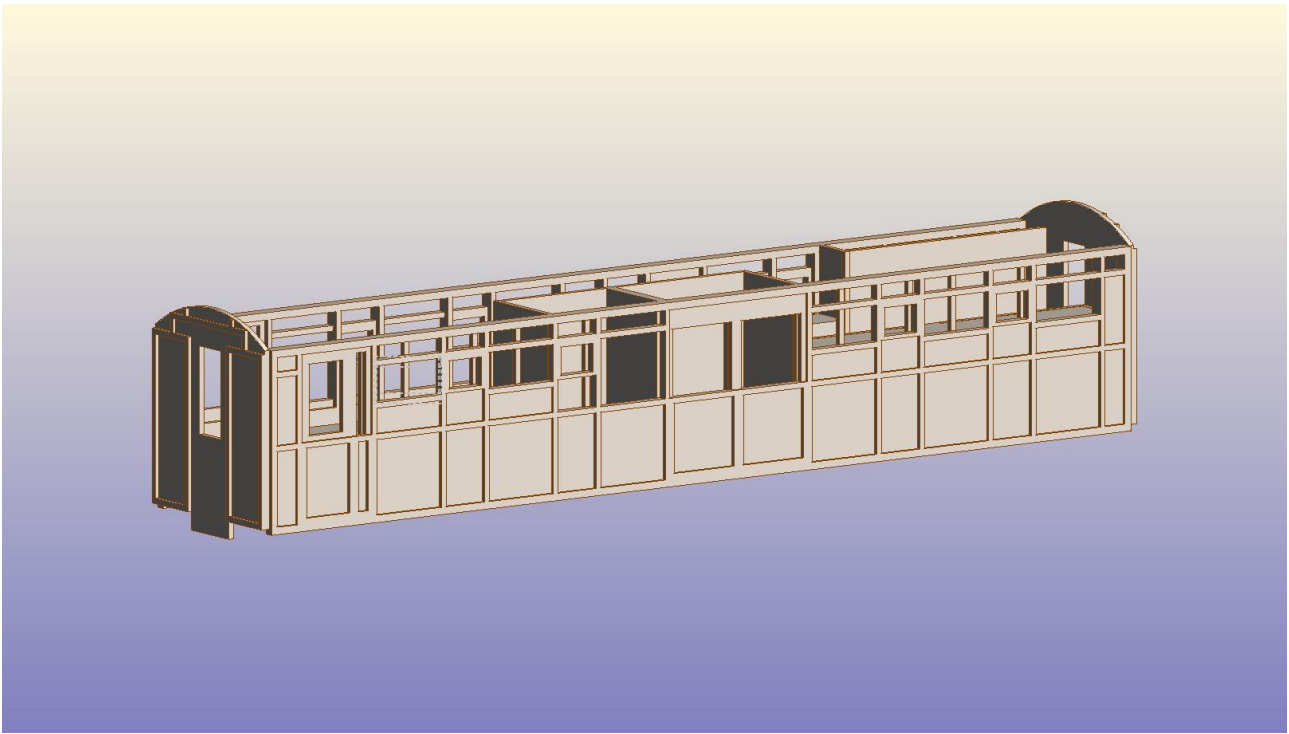

Now its time to glue on the beading. To aid you, there is etched markings on the sides and ends of the coach to show you where they go.

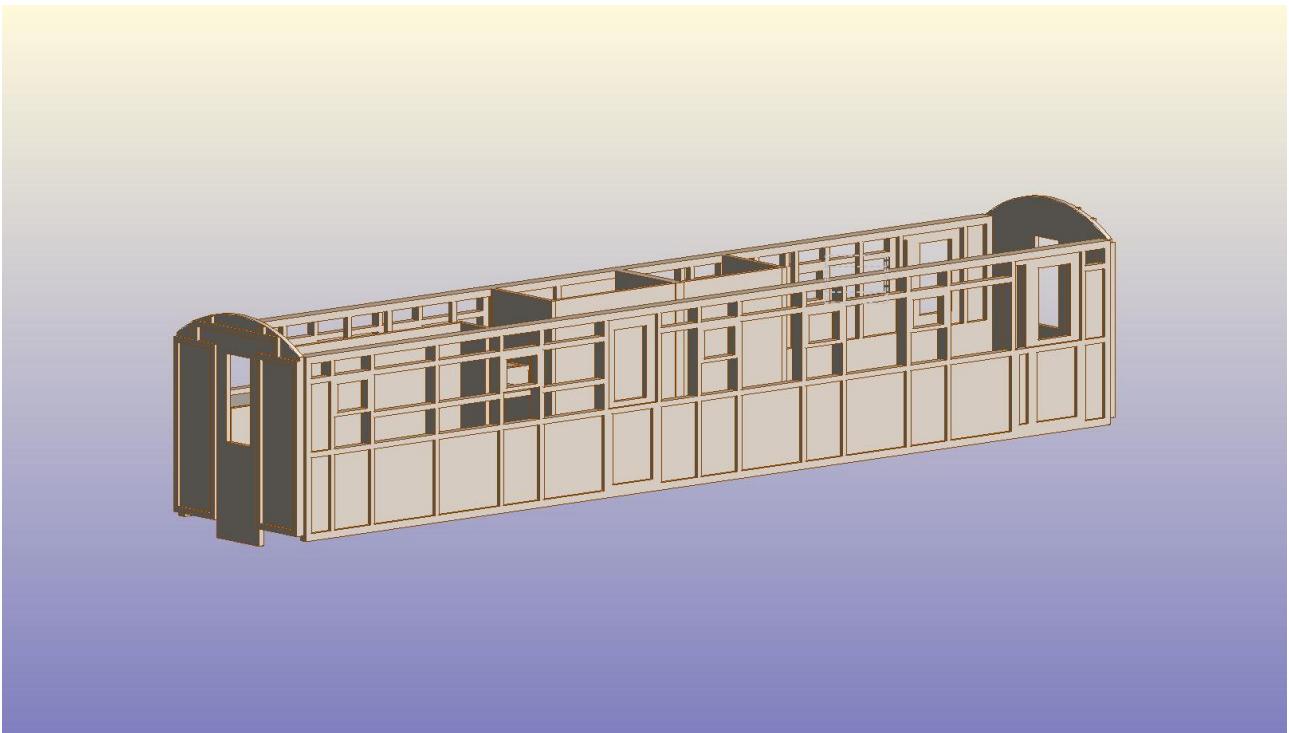

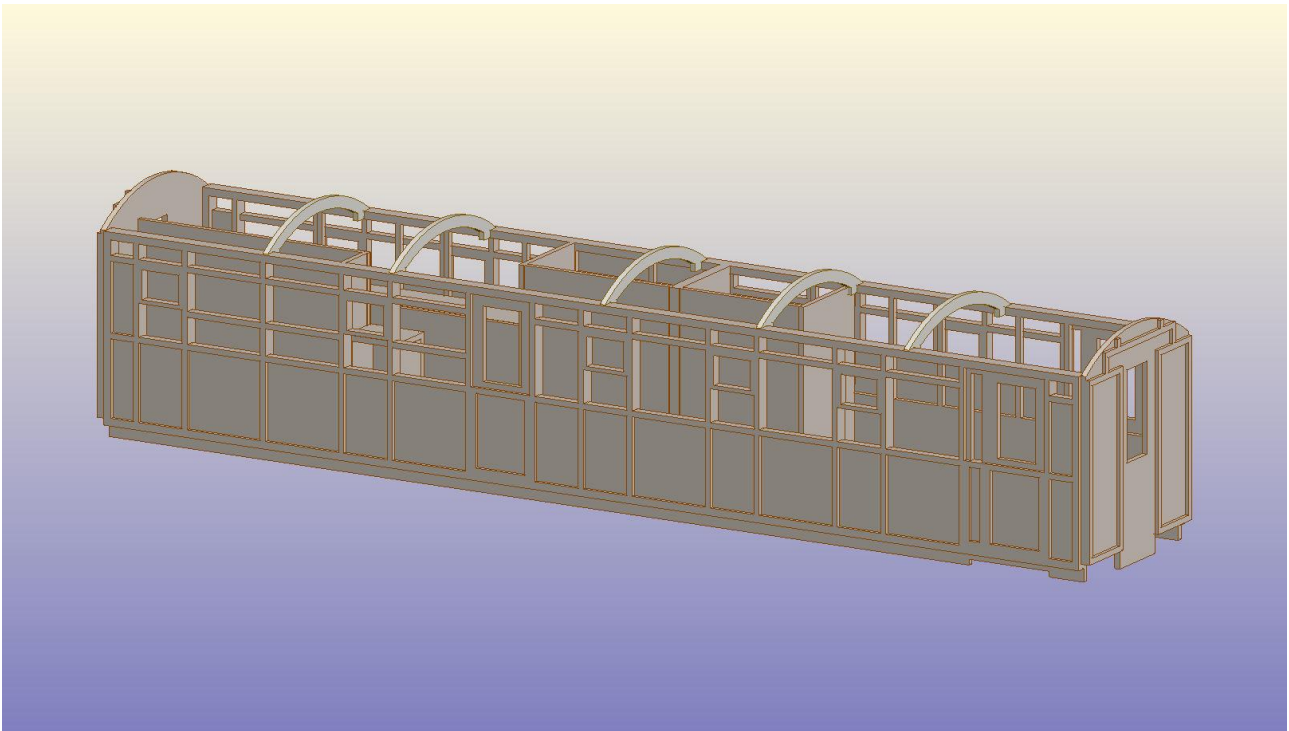

Before installing the roof, a small number of roof supports need to be glued into place. Where you place these is your choice but we recommend placing them equally along the roof

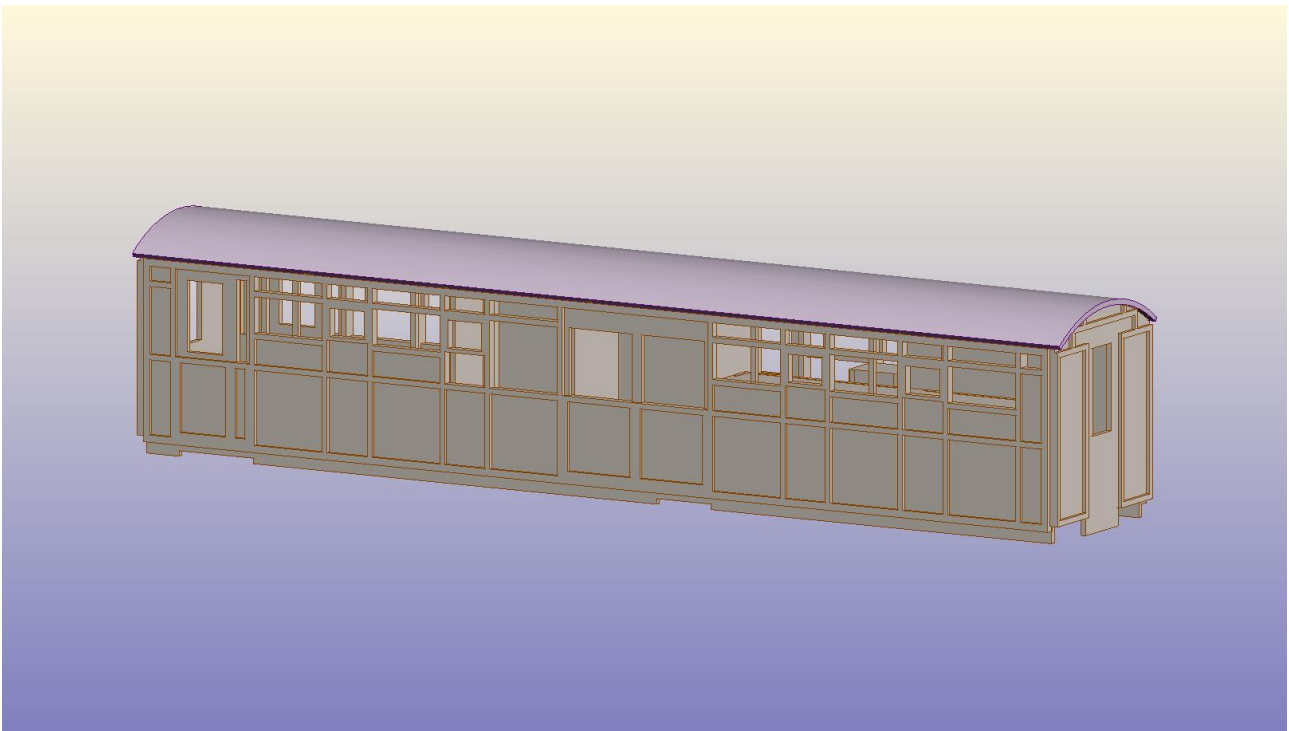

The roof itself is formed of long thin planks of wood which overlap the ends of the coach to cover the entire coach including beading. To cover the roof, we recommend either craft paper, a old shirt/sheet or masking tape all of which once painted give the perfect effect of canvas as well as smoothing the roof's curve.

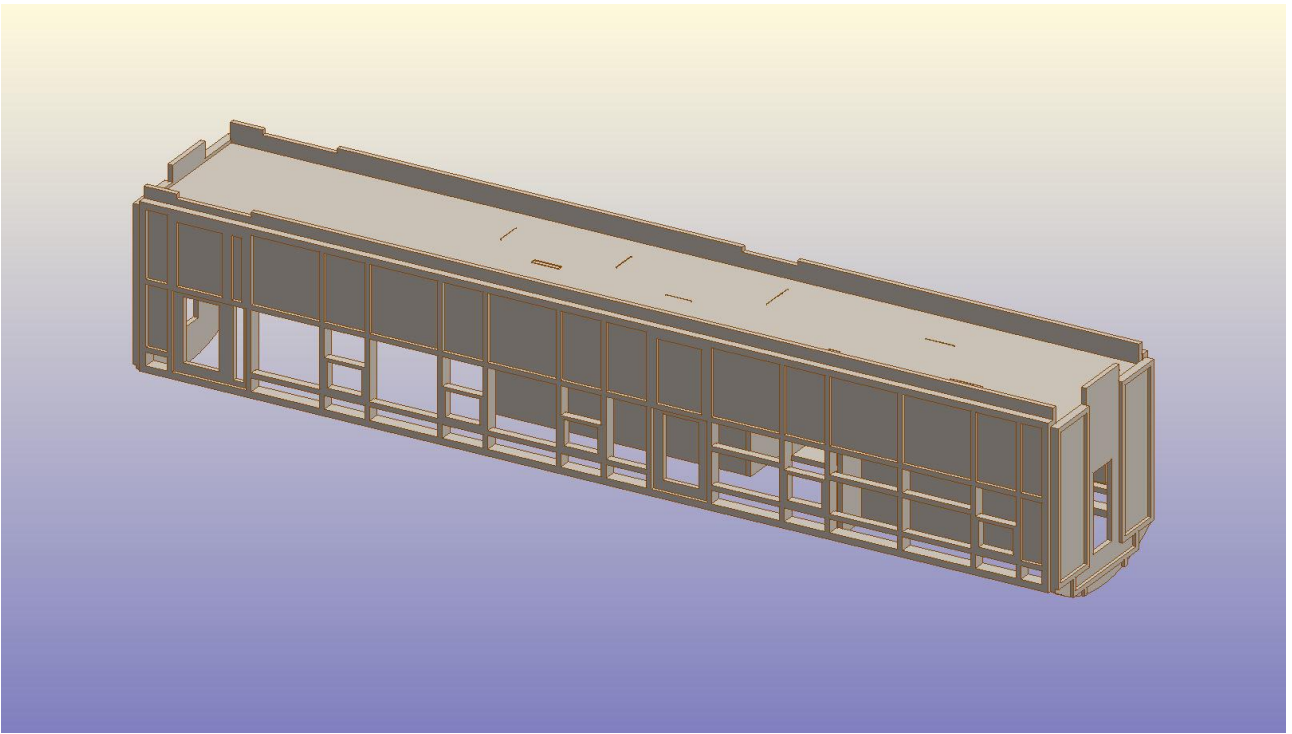

To complete the body, glue the step supports onto the bottom of the chassis making sure they match the door location on your model

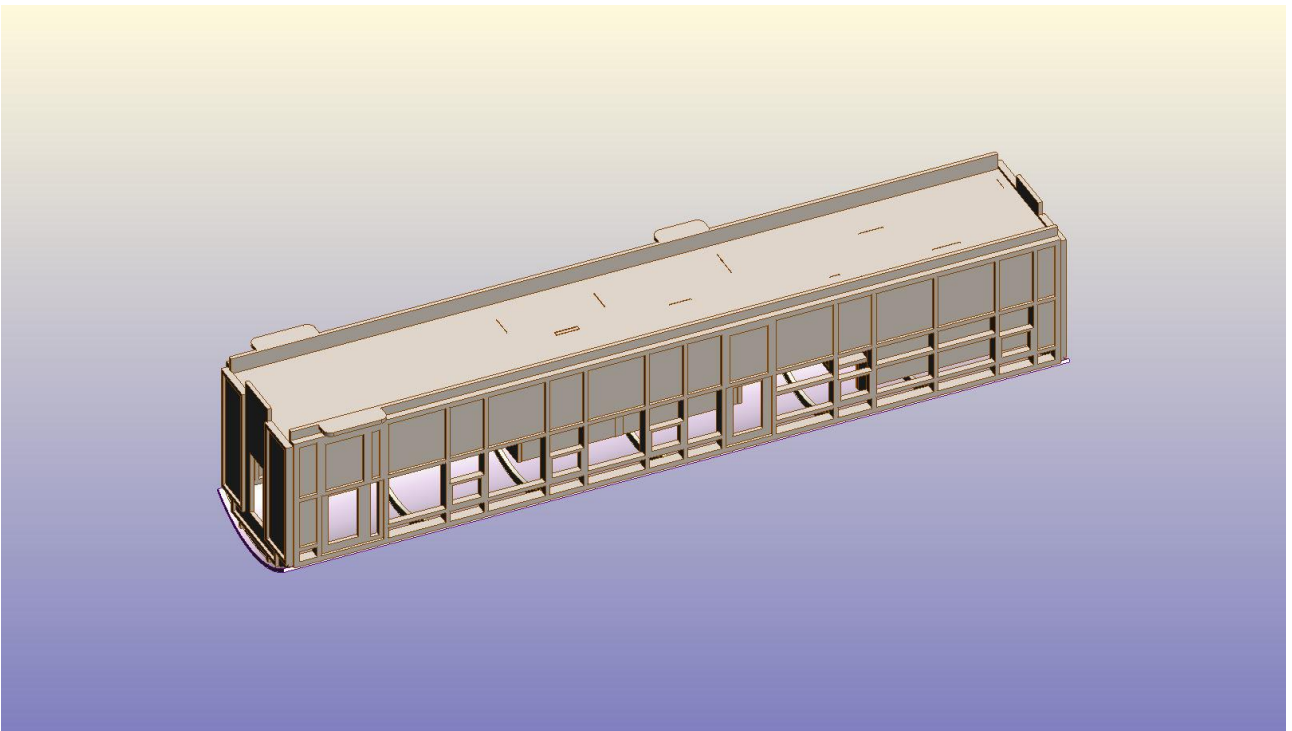

Now glue on the Steps into their slots.

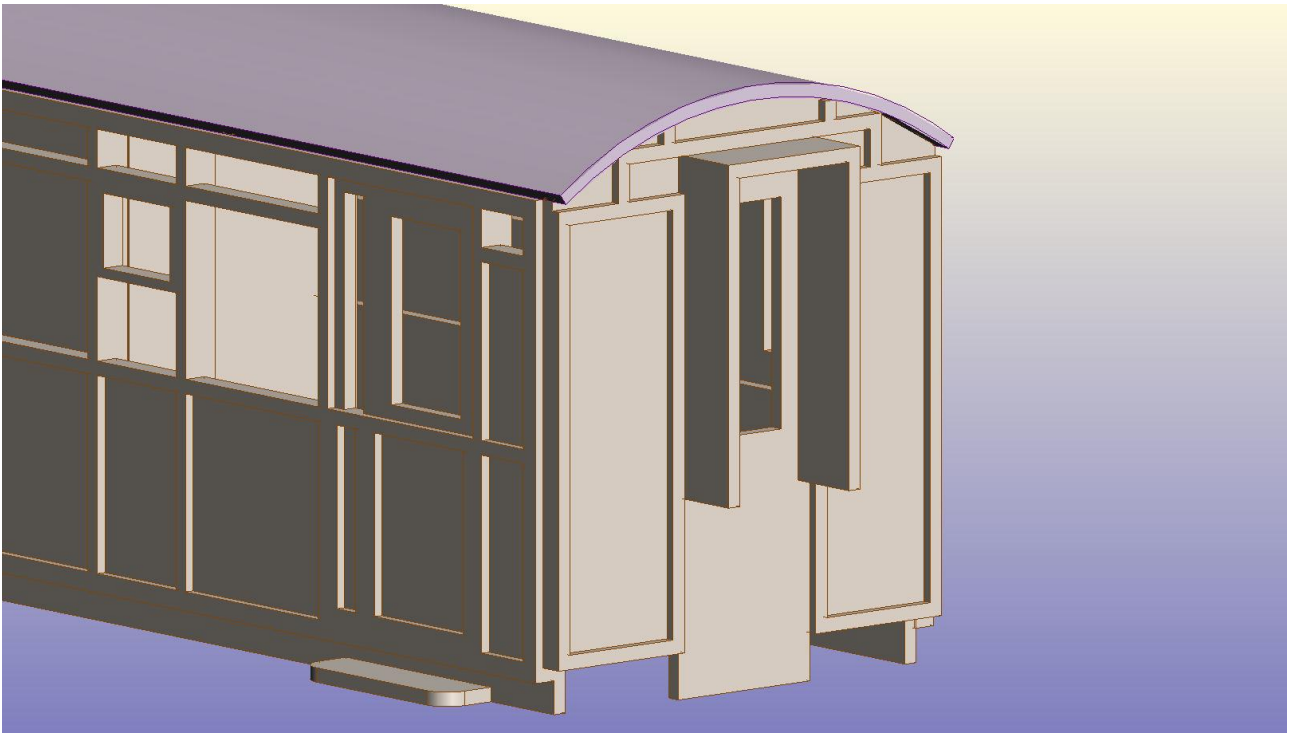

Next, glue in the Corridor Connectors again using the etched marks on the coach end as a guide.

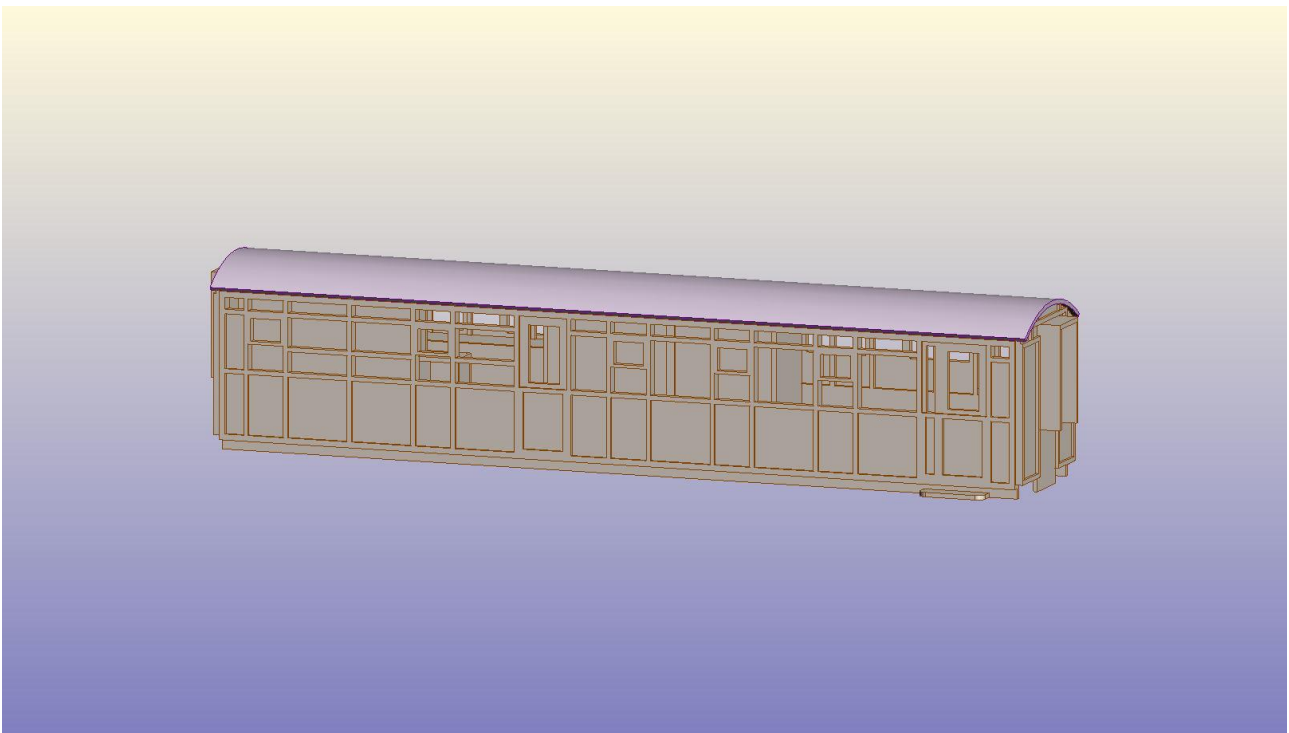

To complete your model, glue the couplings onto the end of the coach at your preferred height and mount the bogies using the mounts provided. We recommend placing them 90mm from the end of your coach.

Your kit is now complete.



We hope you enjoy your Bowaters Models kit! If you have any questions, don't hesitate to contact us on info@bowatersmodels.co.uk

We thank you for your custom.