

Giostra - L LUX

Scheda tecnica
Technical sheet

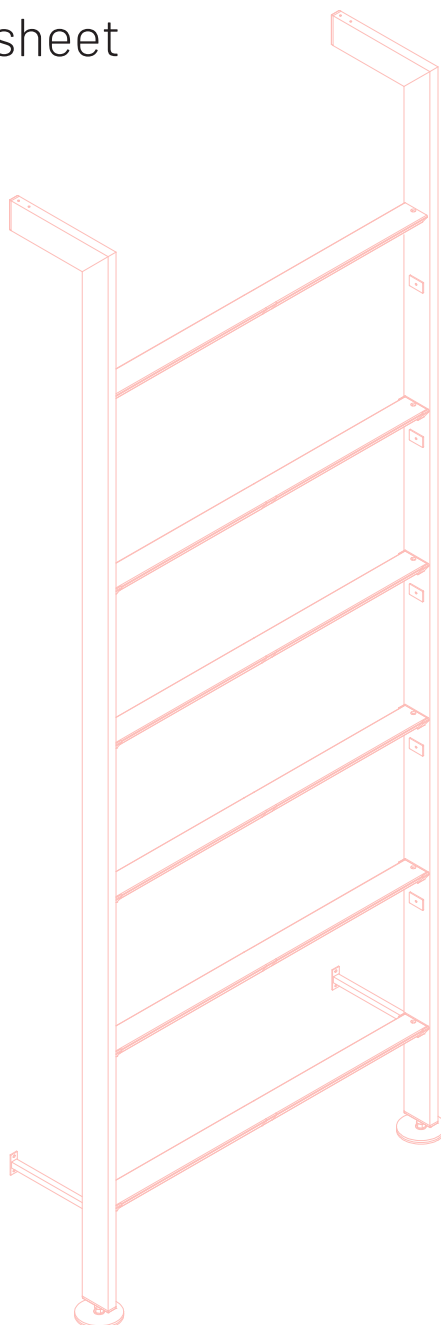

www.damianolatini.it



Damiano Latini s.r.l.
Via Tangenziale 14/16,
62010 - Montecosaro (MC)
email: info@damianolatini.it
P.IVA 01410060436





GIOSTRA - L LUX

Giostra L Lux è una libreria montata a parete corredata da una luce LED di cortesia su ciascuna barra orizzontale. La luce LED diffusa sulla struttura svolge la duplice funzione di esaltare le linee pulite della libreria e contribuire a creare un'atmosfera soffusa e rilassata perfetta per la zona soggiorno. Inoltre, la luce LED a risparmio energetico ti consente di ridurre i consumi e di conseguenza i costi e l'impatto ambientale.

Giostra L Lux is a wall-mounted bookcase made entirely of aluminium is extremely light, functional and water resistant. The aluminium frame rests on the ground and at the same time it fastened to the wall. Led lighting enhance and contributes to make the room cosy and welcoming. It is also possible to set the light intensity through a remote control.





GIOSTRA L LUX - H208

Materiale / Materials
Alluminio / Aluminium



	208 x 60	208 x 90	208 x 120
Kg.	11.2	13.0	14.8
L cm	72.8	102.8	132.8
L1 cm	60.0	90.0	120.0
H cm (min-max)	208.0 - 214.0	208.0 - 214.0	208.0 - 214.0
P cm	29.7	29.7	29.7
X1 cm (min-max)	28.3 - 34.3	28.3 - 34.3	28.3 - 34.3
X2 cm	38.7	38.7	38.7

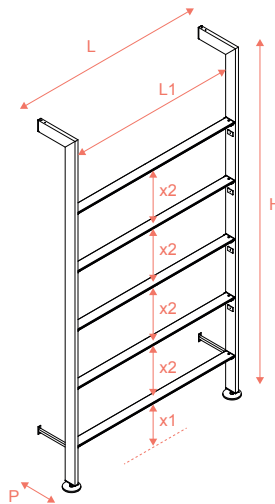

FINITURE / FINISHES

- Ghisa / Cast iron
- Titanio / Titanium
- Nero / Black

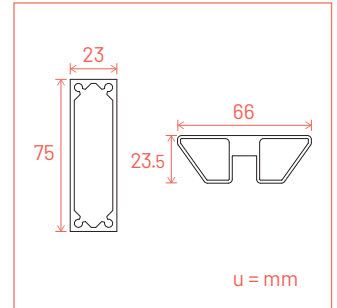

GIOSTRA L LUX - H238

Materiale / Materials
Alluminio / Aluminium

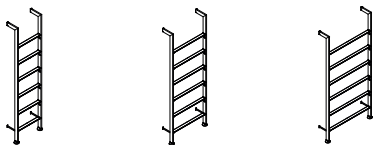

	238 x 60	238 x 90	238 x 120
Kg.	12.2	14.0	15.8
L cm	72.8	102.8	132.8
L1 cm	60.0	90.0	120.0
H cm (min-max)	238.0 - 244.0	238.0 - 244.0	238.0 - 244.0
P cm	29.7	29.7	29.7
X1 cm (min-max)	23.3 - 29.3	23.3 - 29.3	23.3 - 29.3
X2 cm	38.7	38.7	38.7

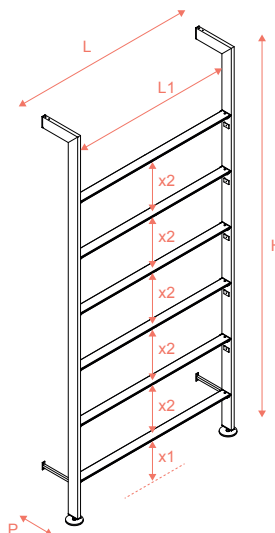

FINITURE / FINISHES

- Ghisa / Cast iron
- Titanio / Titanium
- Nero / Black

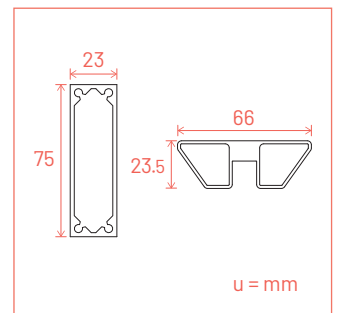

GIOSTRA L LUX - H268

Materiale / Materials
Alluminio / Aluminium



	268 x 60	268 x 90	268 x 120
Kg.	12.7	14.5	16.3
L cm	72.8	102.8	132.8
L1 cm	60.0	90.0	120.0
H cm (min-max)	268.0 - 274.0	268.0 - 274.0	268.0 - 274.0
P cm	29.7	29.7	29.7
X1 cm (min-max)	28.3 - 34.3	28.3 - 34.3	28.3 - 34.3
X2 cm	38.7	38.7	38.7

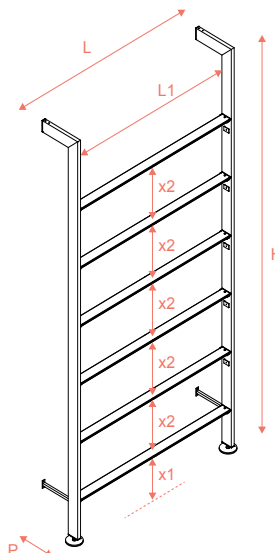

FINITURE / FINISHES

- Ghisa / Cast iron
- Titanio / Titanium
- Nero / Black

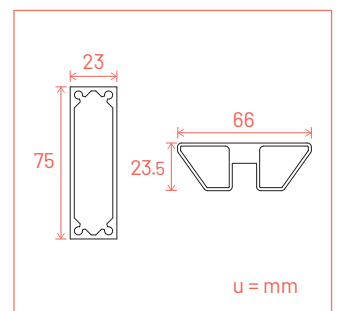

Accessori / Accessories

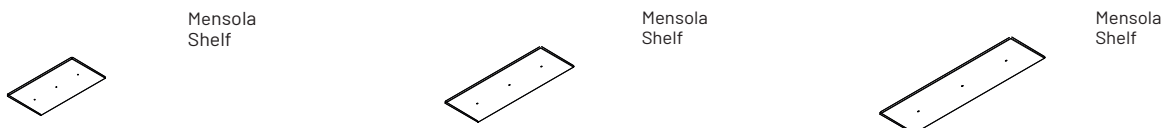

Schema composizioni / Configuration

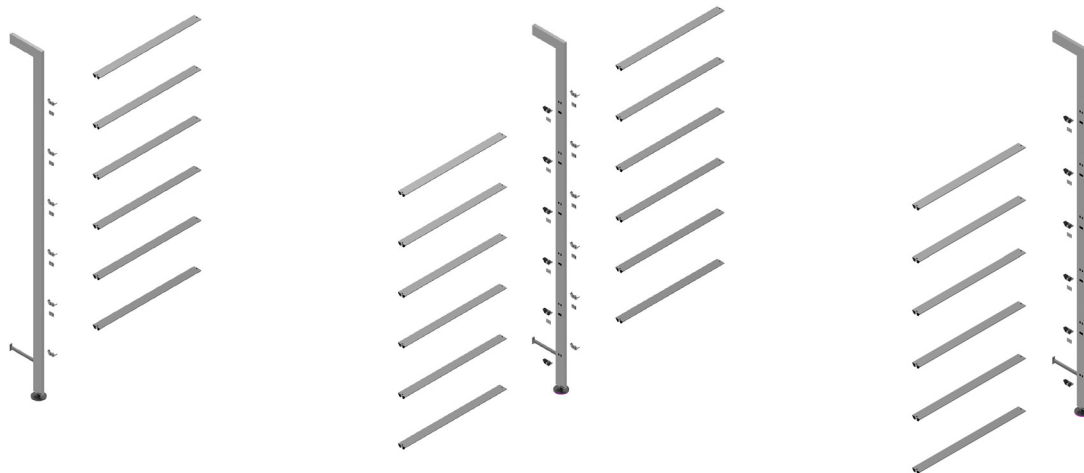

ILLUMINAZIONE

Le nostre illuminazioni integrate da collocare sotto alla traversa orizzontale donano atmosfera, funzionalità e stile. I LED non solo consentono di risparmiare energia, ma grazie a un'illuminazione diffusa, contribuiscono a creare un ambiente rilassato e accogliente. L'illuminazione è controllabile tramite un controller wifi, dal quale è possibile accendere e spegnere le luci e regolarne l'intensità.

LIGHTENING

Our integrated lighting to be placed under the horizontal crossbar enhance our furniture features making them extremely stylish and functional. LED lighting is not only the most energy efficient option on the market but, thanks to light diffusion, it also helps to create a relaxing and pleasant ambience. The lighting can be controlled through a wifi controller, from which it is possible to switch the lights on and off and adjust their intensity.

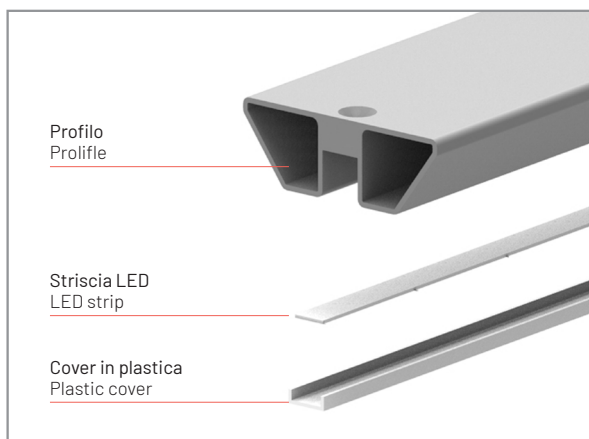

Giostra - L LUX

Scheda di montaggio
Assembly instructions

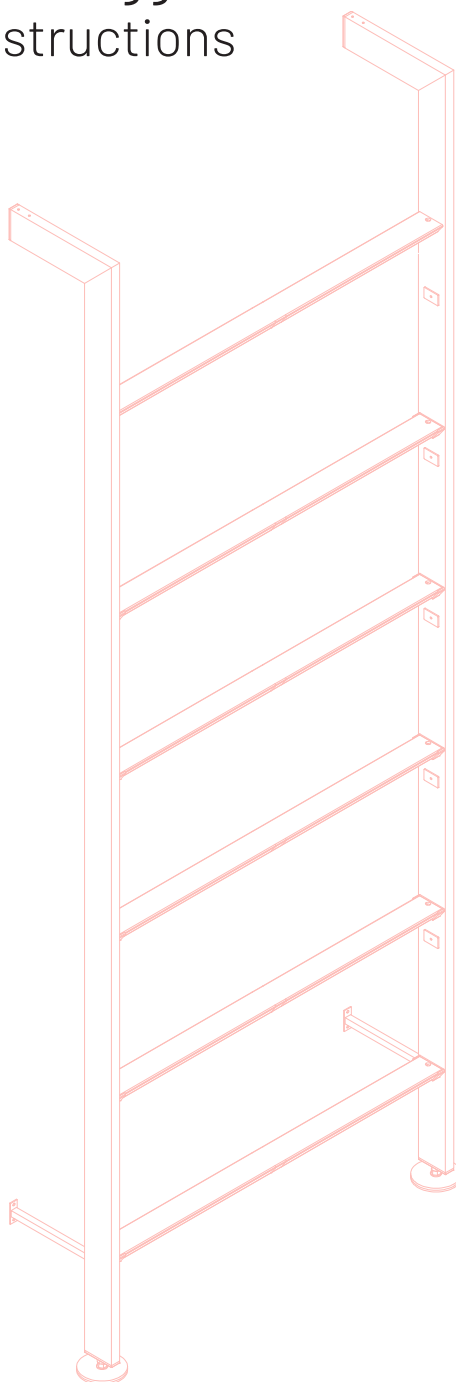





www.damianolatini.it



Damiano Latini s.r.l.
Via Tangenziale 14/16,
62010 - Montecosaro (MC)
email: info@damianolatini.it
P.IVA 01410060436

Giostra - L LUX | H208

Materiale | Materials

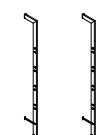
- | | |
|--|--|
| <p>A</p>  <p>Vite da muro + tassello
Self-tapping screws + wall plug
N.8 pcs (4 x 30 mm)</p> |  <p>Barre orizzontali
Horizontal profiles
N.5 pcs</p> |
| <p>B</p>  <p>Vite per ferro
Metric screws
N.10 pcs (M5 x 16 mm)</p> |  <p>Supporti
Supports
N.10 pcs</p> |
| <p>C</p>  <p>Vite per ferro
Metric screws
N.2 pcs (M4 x 22 mm)</p> |  <p>Profilo con piedi + supporti premontati
Aluminium profile + pre-assembled support
N.2 pcs</p> |

Strumenti necessari | Required tools

Trapano | Drill



Cacciavite a croce | Phillips Screwdriver

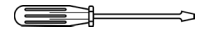

Chiave a brugola | Allen key



Punta trapano | Drill bit



Chiave inglese | Spanner

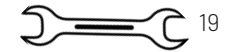

1 Preparare i profili | Set up the profiles

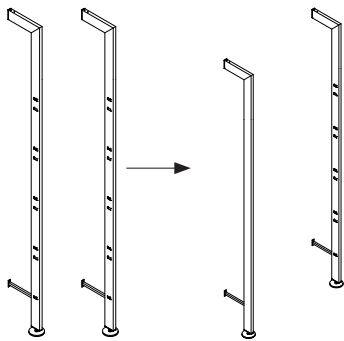

Prendere i profili ed allinearli frontalmente a terra.

Set up the profiles and place them parallel each other.

2 Collegare i connettori | Join the connectors

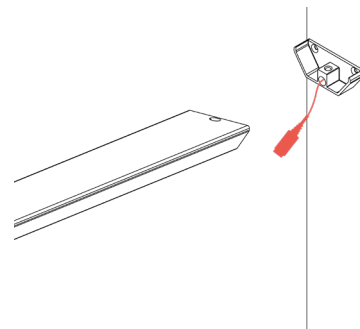

Collegare i connettori del montante con le barre orizzontali.

Join the connectors with the horizontal bars.

3 Fissare le barre | Fit and fix horizontal profiles

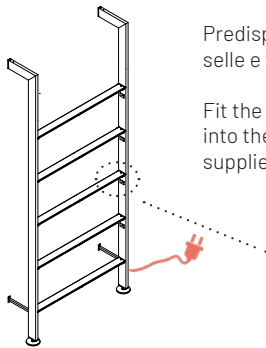

Predisporre le **BARRE FORATE** nelle selle e fissarle con le viti.

Fit the horizontal **PERFORATED** profiles into the supports and fix with the supplied screws.

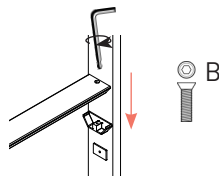

4 Segnare le distanze | Draw distances

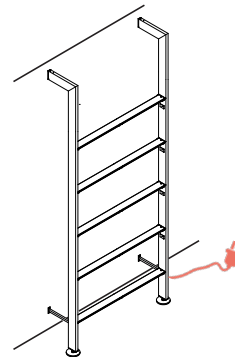

Prendere le distanze sul muro.

Draw distances on the wall.

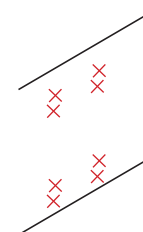

5 Forare il muro | Drill into the wall

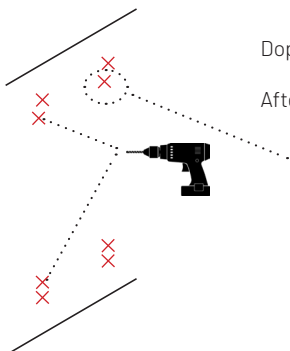

Dopo aver forato avvitare i connettori.

After drill the wall, screw the supports.

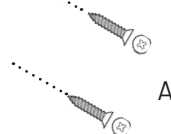

6 Fissare il Giostra-L | Place and fix Giostra-L

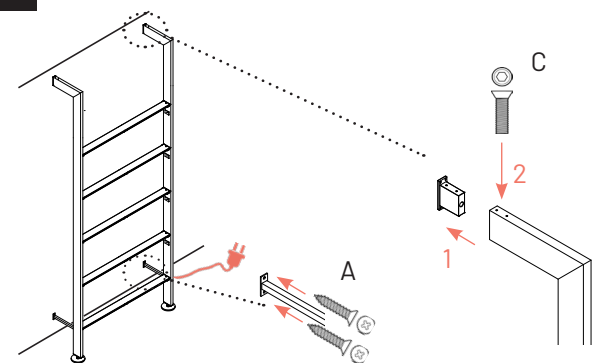





www.damianolatini.it



Giostra - L LUX | H238 | H268

Materiale | Materials

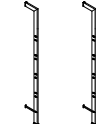
- A**  Vite da muro + tassello
Self-tapping screws + wall plug
N.8 pcs (4 x 30 mm)
 - B**  Vite per ferro
Metric screws
N.10 pcs (M5 x 16 mm)
 - C**  Vite per ferro
Metric screws
N.2 pcs (M4 x 22 mm)
-  Barre orizzontali
Horizontal profiles
N.5 pcs
 -  Supporti
Supports
N.10 pcs
 -  Profilo con piedi + supporti premontati
Aluminium profile + pre-assembled support
N.2 pcs

Strumenti necessari | Required tools

Trapano | Drill



Cacciavite a croce | Phillips Screwdriver

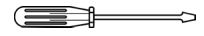

Chiave a brugola | Allen key



Punta trapano | Drill bit



Chiave inglese | Spanner

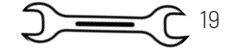

1 Preparare i profili | Set up the profiles

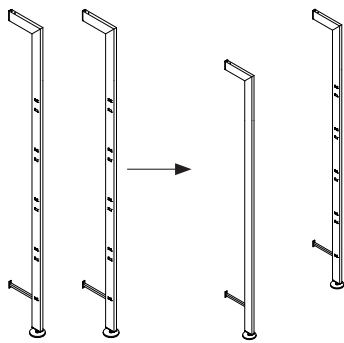

Prendere i profili ed allinearli frontalmente a terra.

Set up the profiles and place them parallel each other.

2 Collegare i connettori | Join the connectors

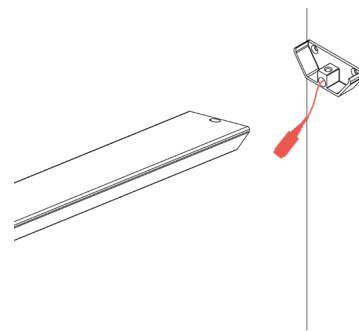

Collegare i connettori del montante con le barre orizzontali.

Join the connectors with the horizontal bars.

3 Fissare le barre | Fit and fix horizontal profiles

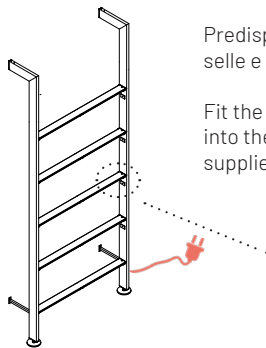

Predisporre le **BARRE FORATE** nelle selle e fissarle con le viti.

Fit the horizontal **PERFORATED** profiles into the supports and fix with the supplied screws.

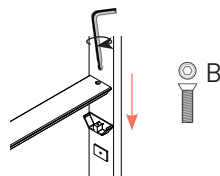

4 Segnare le distanze | Draw distances

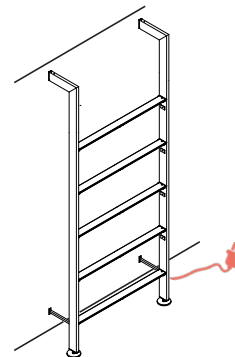

Prendere le distanze sul muro.

Draw distances on the wall.

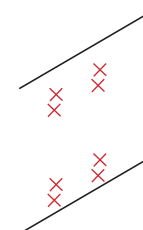

5 Forare il muro | Drill into the wall

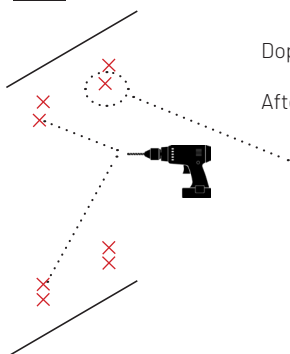

Dopo aver forato avvitare i connettori.

After drill the wall, screw the supports.

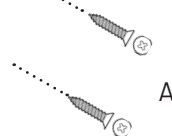

6 Fissare il Giostra-L | Place and fix Giostra-L

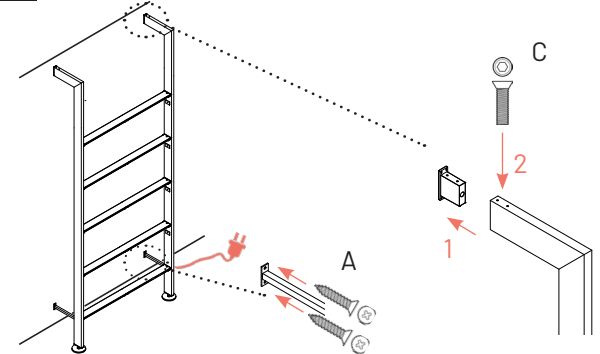

www.damianolatini.it

