

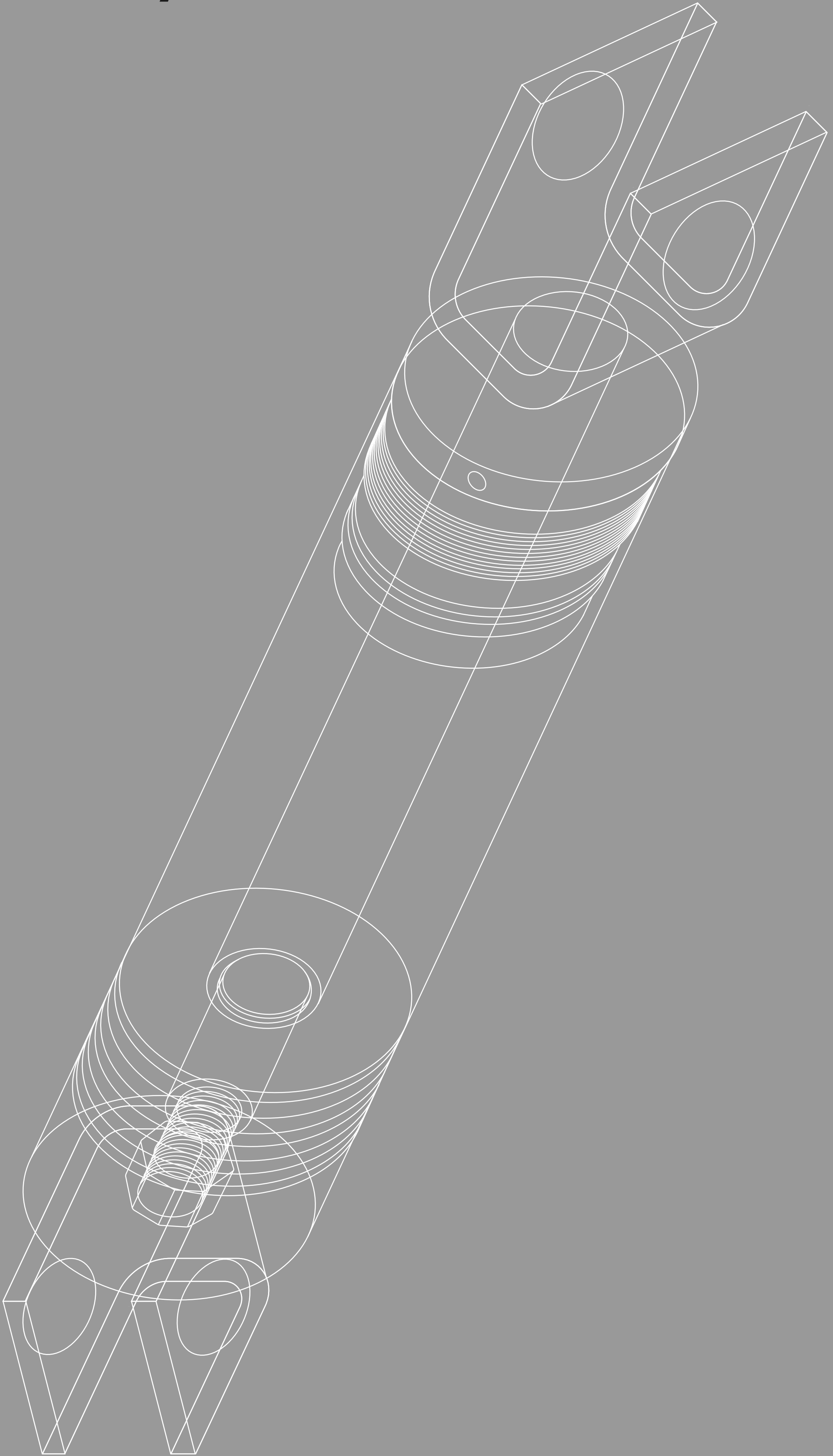

# Disassembling and rebuilding a hydraulic ram

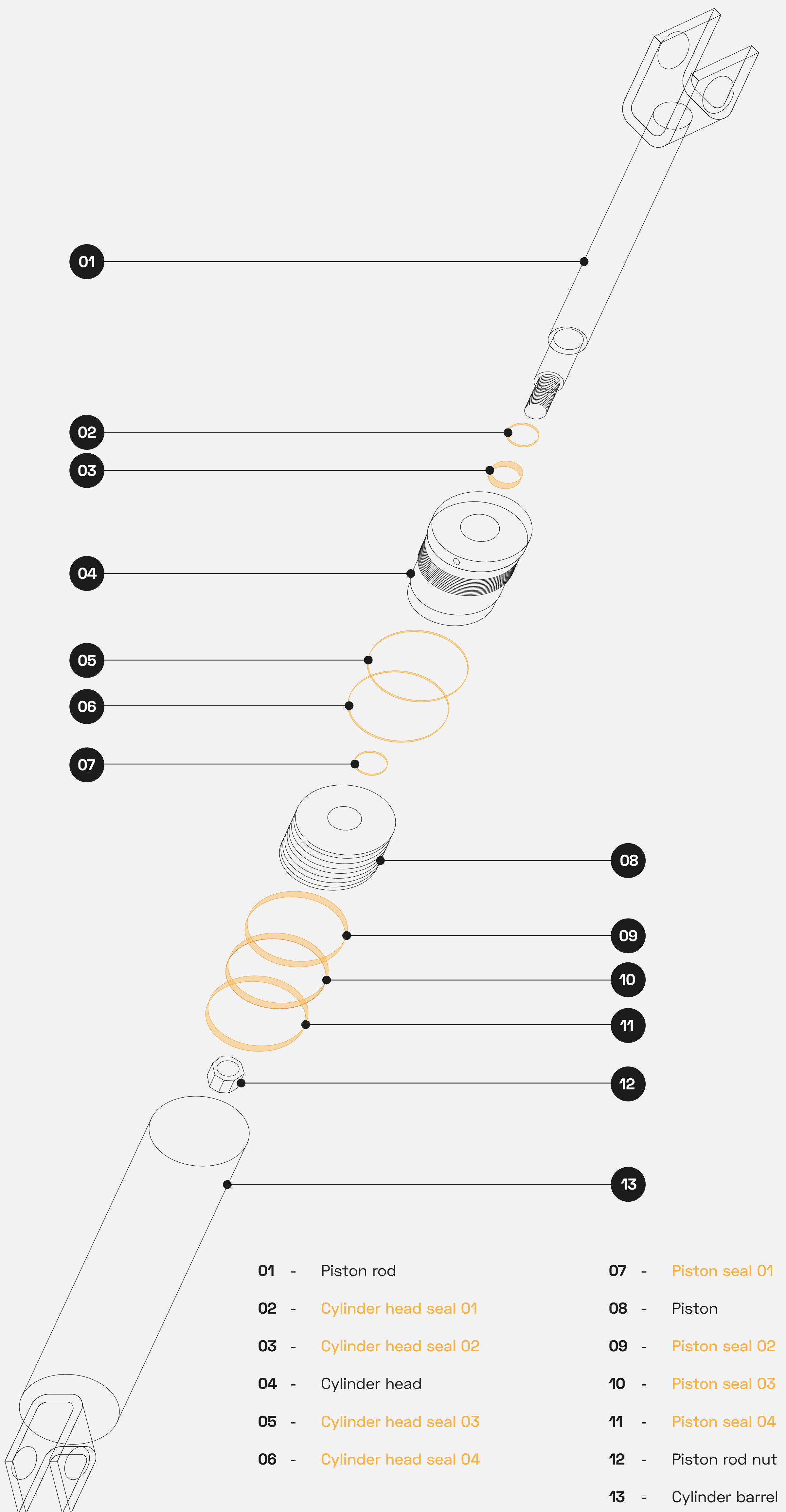

# Components of a hydraulic ram



# Tools and parts you will need

---

## Tools

- C Spanner or peg spanner
- Spanner
- Precision screwdriver
- Paper towels
- Worktop vice
- Small brass brush
- Several spare washers that fit the piston rod

## Parts

- A Tohren hydraulic ram rebuild kit\*
- Hydraulic oil

## Step 01 Unscrewing the ram

---

Secure the hydraulic ram vertically in a worktop vice. **A**

Using a C Spanner or peg spanner, unscrew the cylinder head from the cylinder barrel.

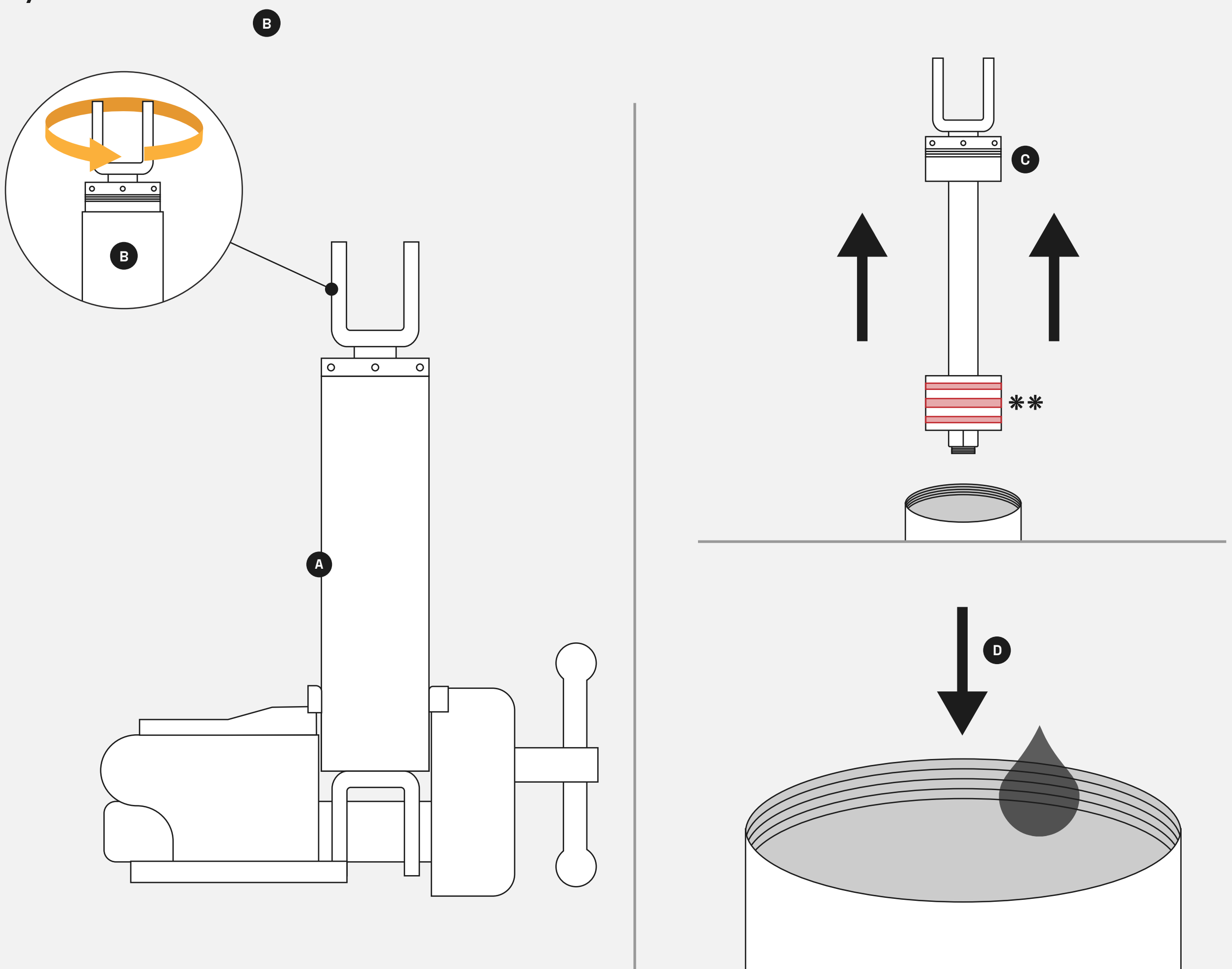

Remove the cylinder head, piston and piston rod from the cylinder barrel. **C**

Thoroughly clean the inside of the cylinder barrel with paper towels and hydraulic oil, paying attention to the threads at the top of the cylinder barrel. **D** Ensure **NO** fragments of dirt fall inside the cylinder barrel.

\* NOTE - When following this guide, notice that the OLD seals are red and NEW seals are yellow.

\* NOTE - The amount of seals on different hydraulic rams vary, so replace **like for like**.

## Step 02 Disassembling the piston and cylinder head

Remove the cylinder barrel from the vice\* and vertically secure the piston rod, cylinder head and piston in the vice, with the **piston** at the top of the rod. **A** Using a spanner or impact wrench, remove the piston rod nut. **B**

Lift off both the piston, and piston seal 01 from the piston rod. **C**\*\*

Slide the cylinder head off the piston rod. **D**

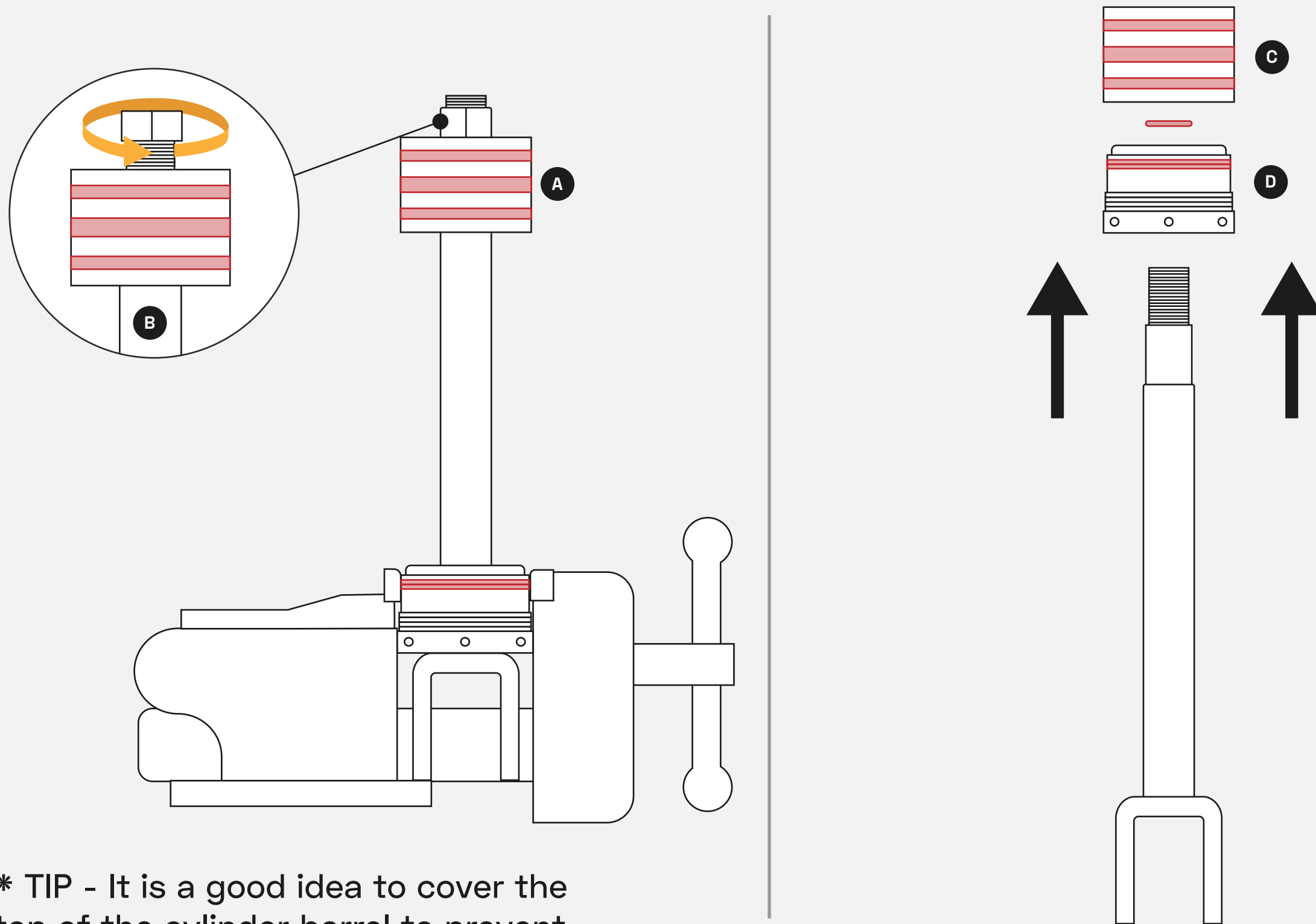

\* TIP - It is a good idea to cover the top of the cylinder barrel to prevent dirt and debris falling into it.

## Step 03 Removing/replacing the seals on the cylinder head

Using a precision screwdriver, remove cylinder head seal 01. **A** The old seal might be broken so ensure to remove and clean the seal and the seal groove it sits in thoroughly.

Remove cylinder head seal 02, which sits inside the cylinder head. **B**

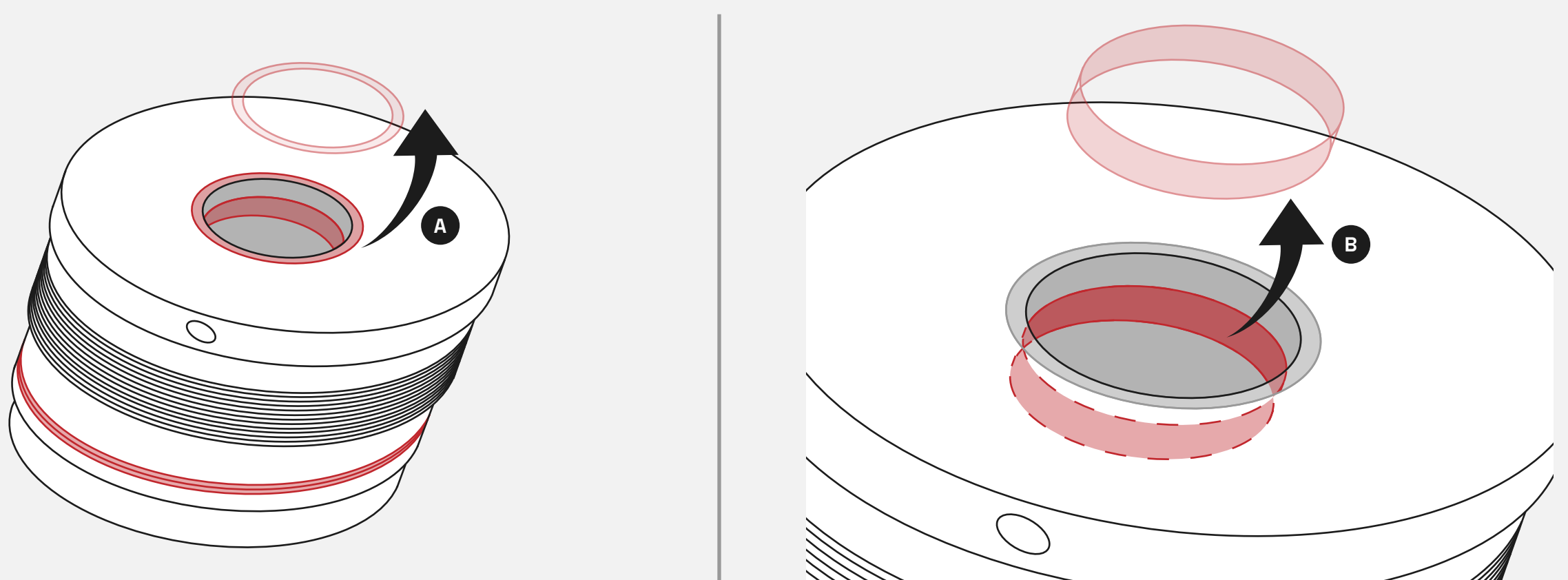

\*\* TIP - When taking apart the hydraulic ram, pay attention to the order of the parts as you disassemble it. Laying all the parts on your workbench in the right order is also a good idea.

Using a precision screwdriver, remove the two outer seals (cylinder head seals 3 and 4) from the cylinder head. **B**

Thoroughly clean the cylinder head, using a brass brush to remove any dirt from the seal grooves. Apply hydraulic oil to the cylinder head.

Replace all four seals on the cylinder head. **C**\*

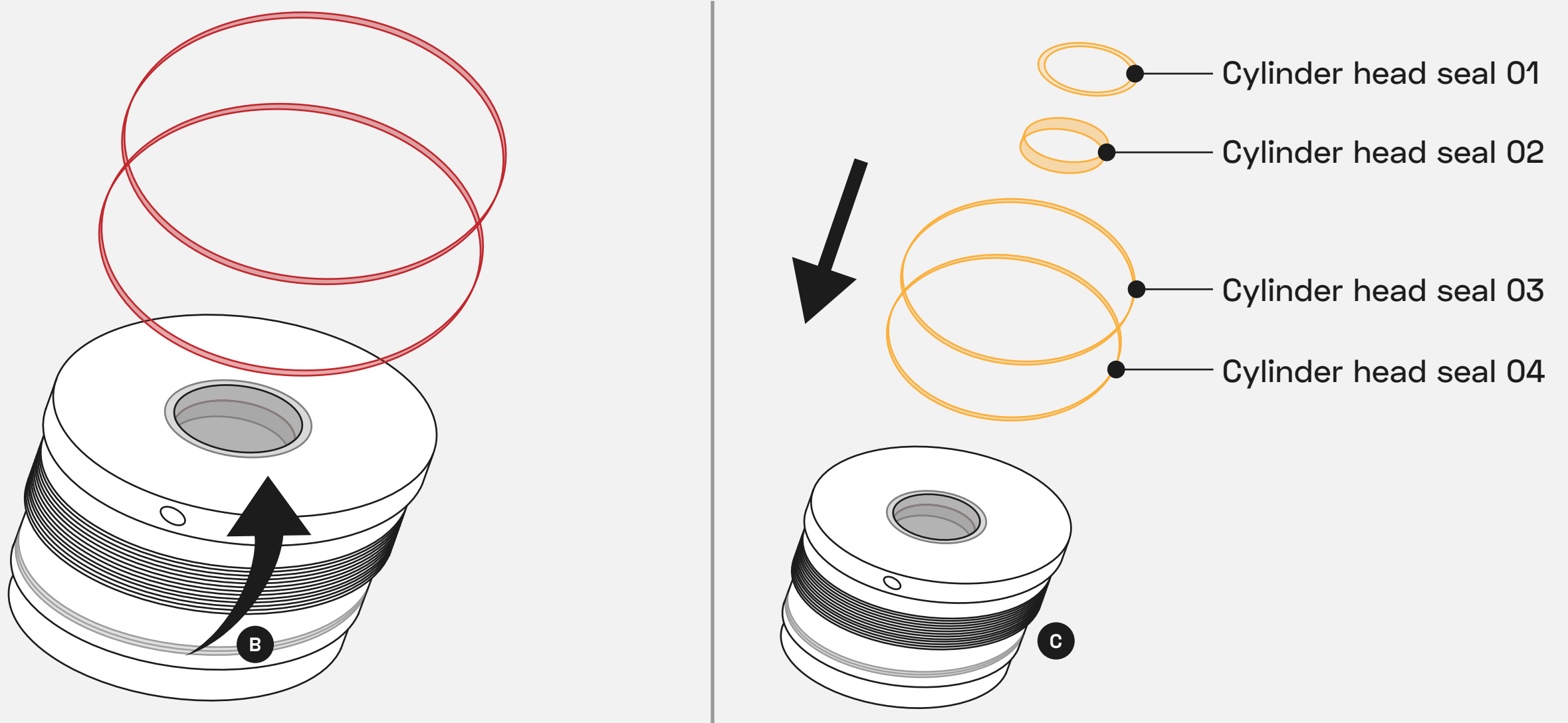

\* TIP - The internal seal 02 is difficult to insert so you may need to soften the seal in warm water or use a seal installation tool.

## Step 04 Removing/replacing the seals on the piston

Remove the three old seals from the outside of the piston. **A** Clean the piston and ensure the seal grooves are free from dirt. Apply hydraulic oil to the piston. **B** Put the three new seals on the piston. **C**

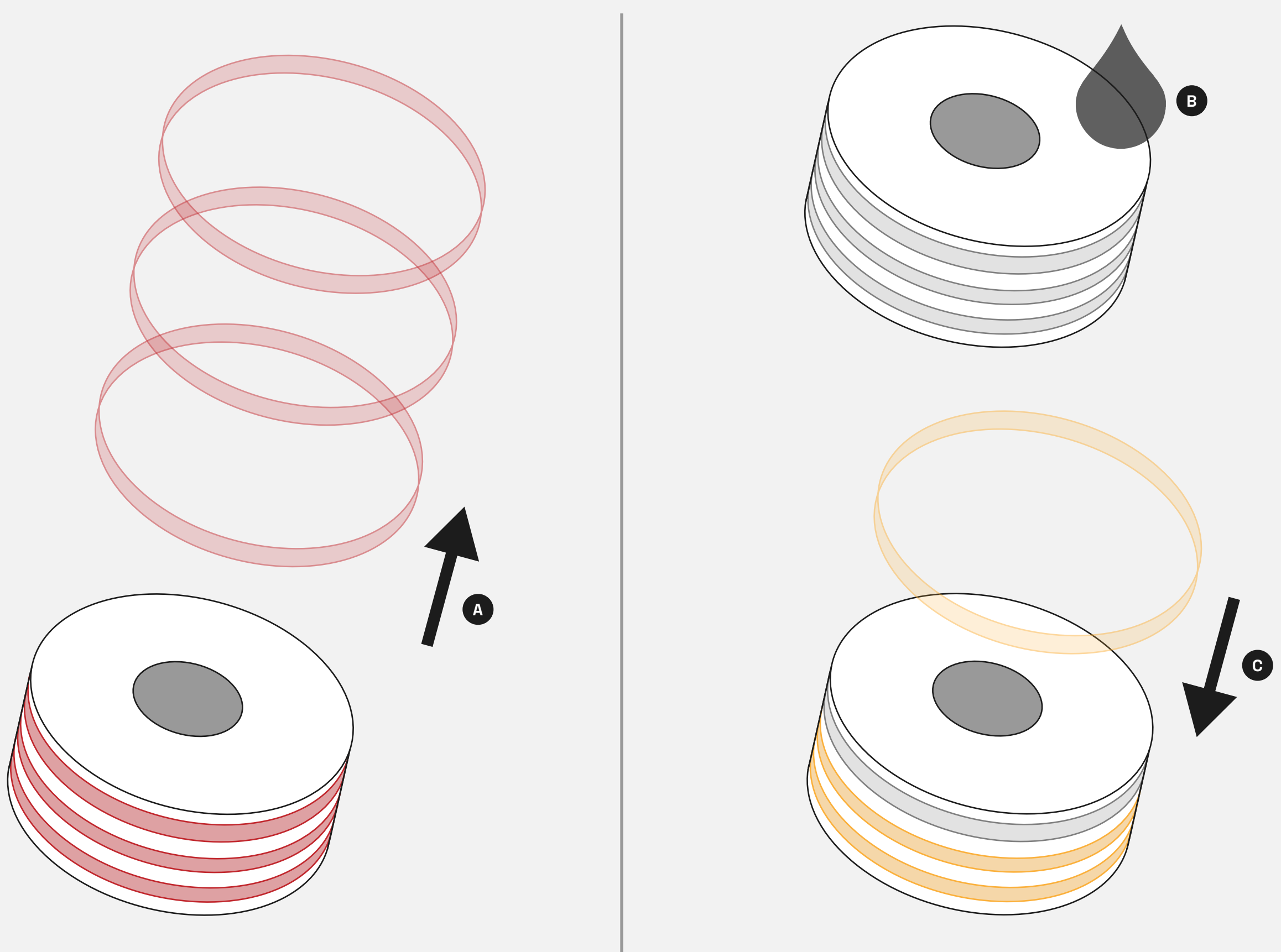

## Step 05 Rebuilding the piston and cylinder head onto the piston rod

Thoroughly clean the piston rod and apply hydraulic oil to it. The cylinder head now needs to be placed onto the piston rod, and because of the new seals it will not easily slide down the rod, so put a number of washers on the top of the cylinder head, and replace the piston nut. **A** Now tighten the piston nut. If the cylinder head cannot now be easily pushed down the piston rod, you may need to add more washers. **B**

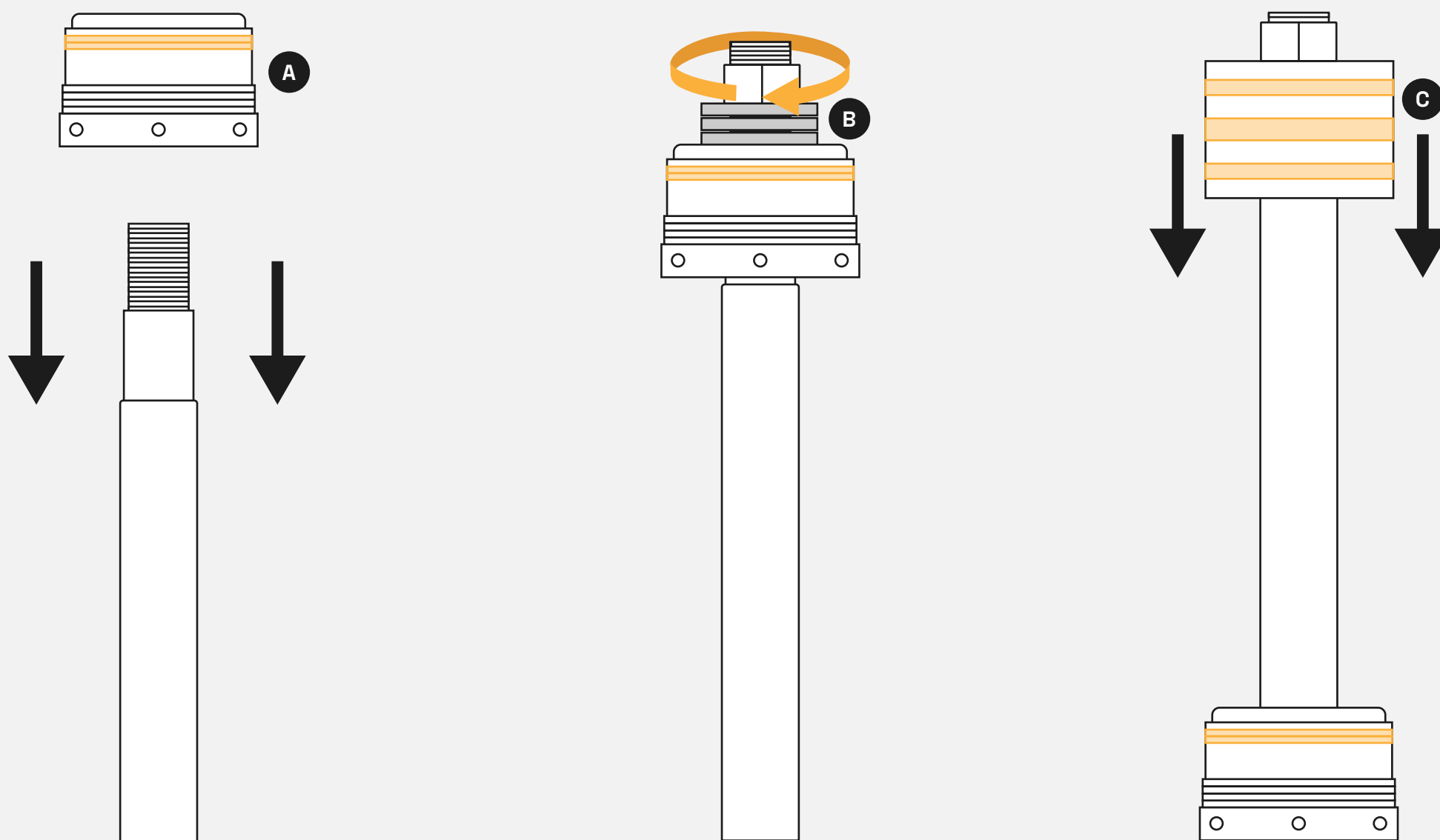

Next, put the piston seal 01 over the piston rod. Replace the piston, and then screw on the piston rod nut tightly. **C**

## Step 06 Fitting the piston rod back into the cylinder barrel

Remove the rebuilt piston rod from the vice, and secure the cylinder barrel vertically in the vice again. Double check the inside of the barrel is completely free of dirt and debris, and is well lubricated with hydraulic oil.

Slide the piston rod piston end first into the cylinder barrel. **A** Screw the cylinder head end of the piston rod back onto the cylinder barrel and then use the hydraulic wrench to fully tighten. **B**

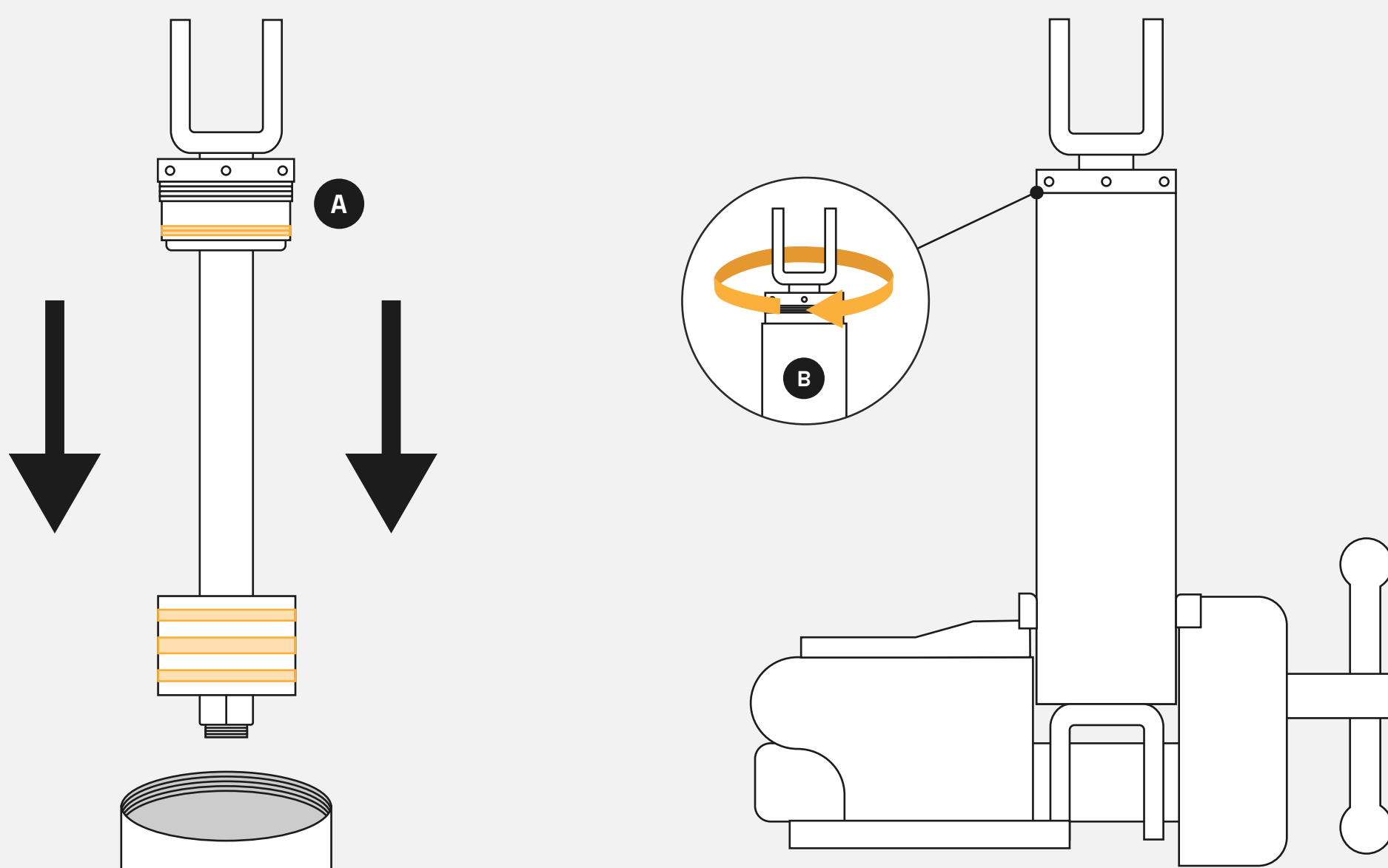



## **We know hydraulics**

For individuals, fleet and distributors looking for high-quality hydraulic seals, Tohren offers a huge range of the best selling seals.

Tohren's products are precision engineered to ensure long service life and superb working performance.

Satisfied customers combined with fast lead times and industry leading prices set us apart from our competitors.

[sales@tohren.com](mailto:sales@tohren.com)

[www.tohren.com](http://www.tohren.com)

Tohren UK, Middlesbrough Road, Middlesbrough  
TS6 6LZ