

From Eye to Insight



SHINE A NEW LIGHT ON INDUSTRIAL SAMPLES

The DM750 M



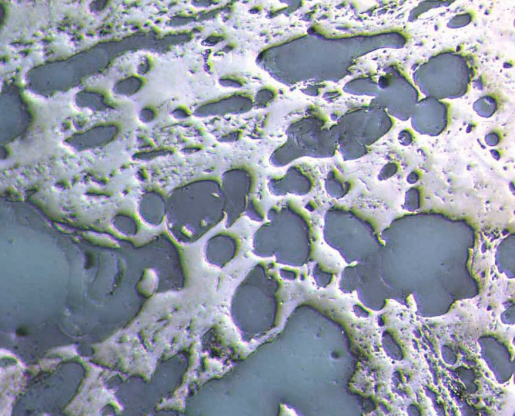

Polished light metal, reflected light, brightfield-oblique contrast

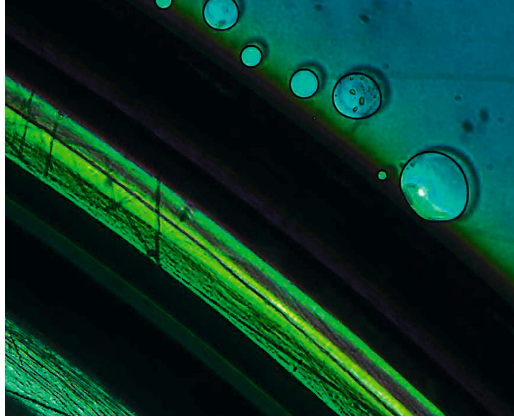

DVD, reflected light, brightfield, crossed polarizer

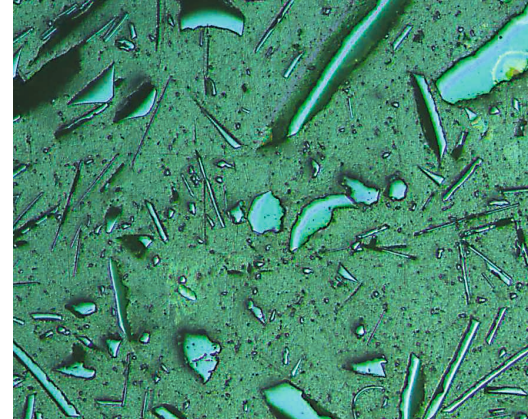

Polished metal sample, reflected light, brightfield



SIMPLY MICROSCOPY FOR ROUTINE TASKS IN MATERIALS QC AND TEACHING

An easy-to-use microscope makes a laboratory function more efficiently. The user can concentrate on the task at hand rather than on complex microscope functions. The Leica DM750 M is an entry-level materials microscope for brightfield, oblique, and polarized light. It is specifically designed to serve the needs of routine quality control and materials analysis in industry as well as the general educational needs in universities, and technical colleges.

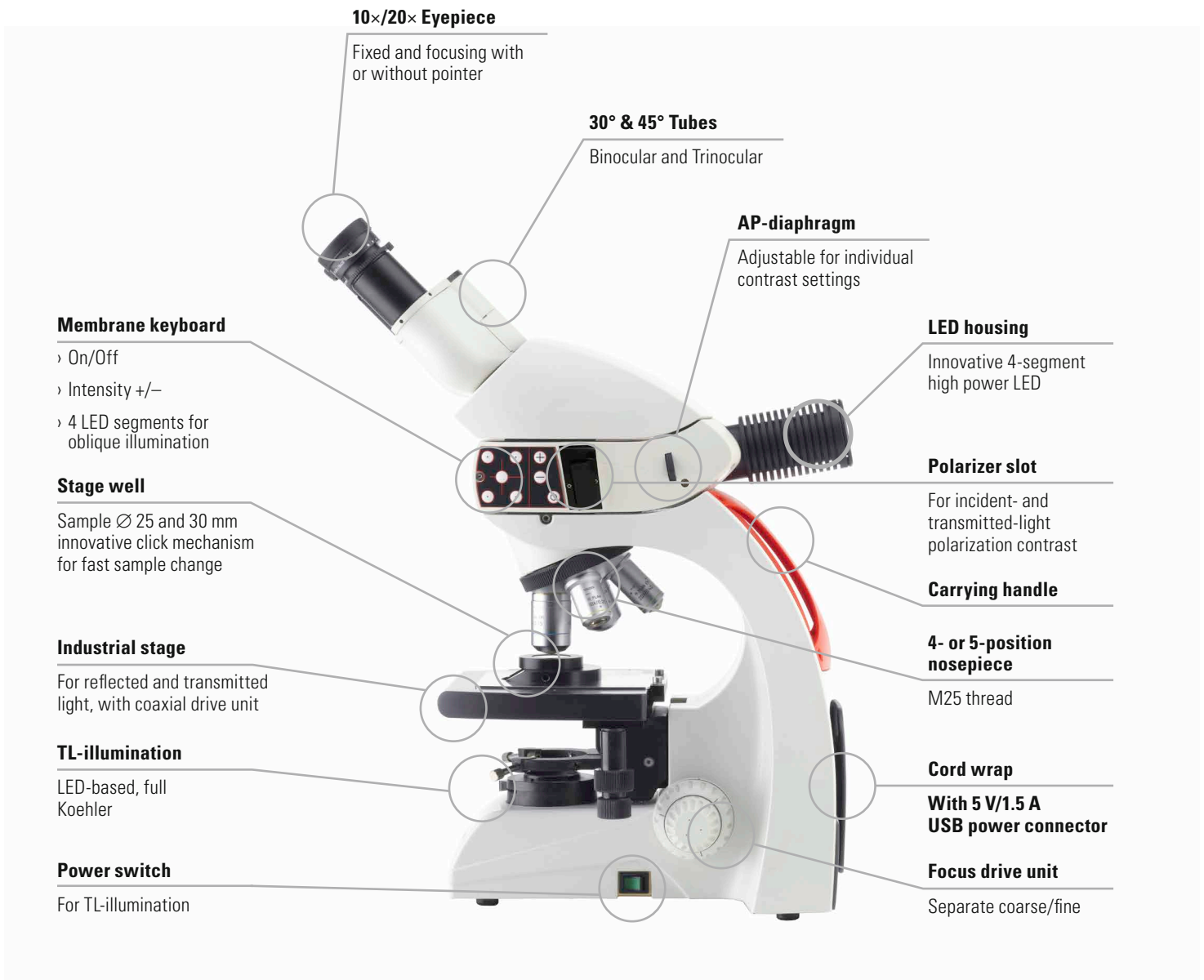

PERFORMANCE RELOADED

The Leica DM750 M combines numerous innovative features to create a unique solution for routine applications in metallography and general materials microscopy.

REFLECTED LIGHT ILLUMINATOR WITH CUTTING-EDGE LED ILLUMINATION

- › Built-in adjustable aperture diaphragm, produces bright and crisp lighting for all samples
- › Ergonomically-positioned membrane-keyboard for easy, intuitive operation of all reflected light settings
- › Innovative 4-segment LED provides bright and homogeneous BF and oblique illumination (quarter / half, direction selectable)
- › Intuitive control for LED-light intensity
- › Power on/off switch distinctly separated from other keys to avoid operating errors
- › Reflected light illuminator incorporates two slots that allows the use of a polarizer and analyzer for polarized light applications
- › Power to the LED reflected light illuminator is provided via a USB cable from the 5 V/1.5 A USB power connector on the rear of the Leica DM750 M stand. This saves the cost of an external power supply plus reduces the complexity at the workstation.



ILLUMINATION OPTIONS

- › LED illumination is used for reflected and transmitted light. It provides cool, white light with a lifetime of over 20 years, thus saving the time and money spent to exchange halogen bulbs on conventional microscopes
- › Transmitted light Koehler field diaphragm for optimum illumination and contrast
- › Optional condenser available
- › Patented time delay shutoff saves energy by automatically turning off the illumination after two hours of no use (TL only).

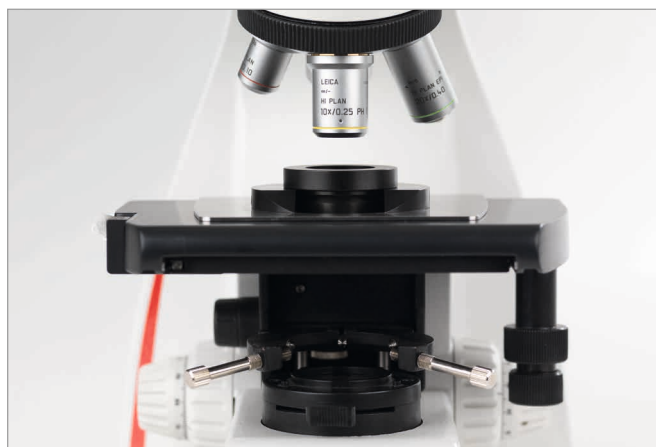

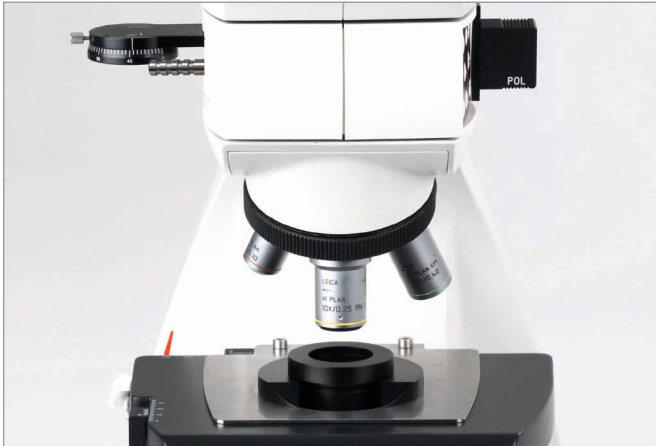

UP TO 1,000×

- › High precision 4- or 5-position objective nosepiece with M25 thread
- › Large selection of high performance objectives starting with HI PLAN EPI series
- › Standard magnification range between 50× and 500× as required by most industrial standards
- › Even higher magnifications, e.g. 1,000×, are possible



EASY SAMPLE HANDLING

- › Universal stage with coaxial drive for reflected and transmitted light applications allows observation of polished and/or etched samples with heights of up to 30 mm
- › Special sample holders with a 25 mm or 30 mm sample diameters
- › Object guide for precise X/Y positioning of the sample



EASY AND ERGONOMIC OPERATION

- › 4- or 5-position nosepiece with rubber covered knurled ring for fast and easy change of objective magnification. The highly accurate machining of the nosepieces ensures parcentration of all objectives in use.
- › 4 different tubes to fit the ergonomic needs of different users: 45° angle binocular or trinocular tube or, 30° angle binocular or trinocular tube
- › All tubes have adjustable interpupillary distance and locking mechanisms for the eyepieces, avoiding loss / theft of equipment.
- › The eyepieces with magnification factor 10 and FOV 20 are available as fixed and focusable to compensate different vision requirements for defective eyesight.

BRILLIANT VIEWS WITH HD IMAGING

The ability to capture, analyze, archive, and share micro-images has always been an important task in the materials laboratory. Leica Microsystems offers an extensive range of advanced digital imaging solutions to exactly match camera and software performance to the needs of your specific application.

LEICA MICROSYSTEMS IMAGING

- › A large variety of Leica microscope cameras including full HD live image. Leica cameras provide high resolution pictures and fast live images.
- › Leica software is the modular platform for easy camera control, image capture, annotation, measurement, and documentation.
- › Customize your own imaging solution using a wide selection of optional software modules.
- › Store and recall: for instantly perfect results for all samples
- › Expert modules for easy-to-use grainsizing and phase analysis according to international norms and standards.
- › The modular design of the system allows easy upgrades and service.
- › Trinocular viewing tubes and C-mount adapters provide the versatility to use stand-alone cameras, which opens the door to unlimited imaging possibilities.

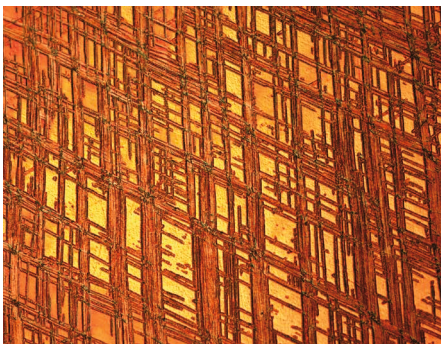

Copper-zinc deformation line



Grain sizing reticle overlay



Polished section of rock



Weld structure, brightfield

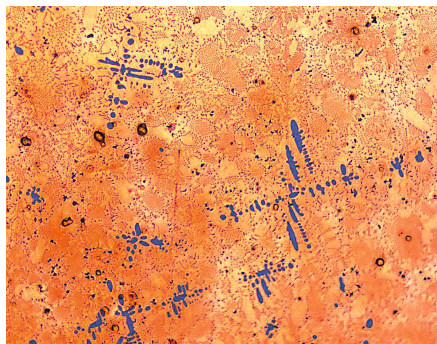

Brass sample, brightfield

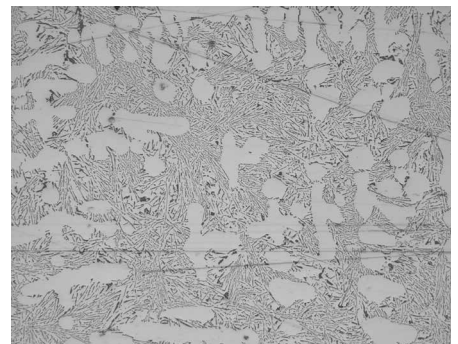

Aluminum-silicon, brightfield

Full HD
1080

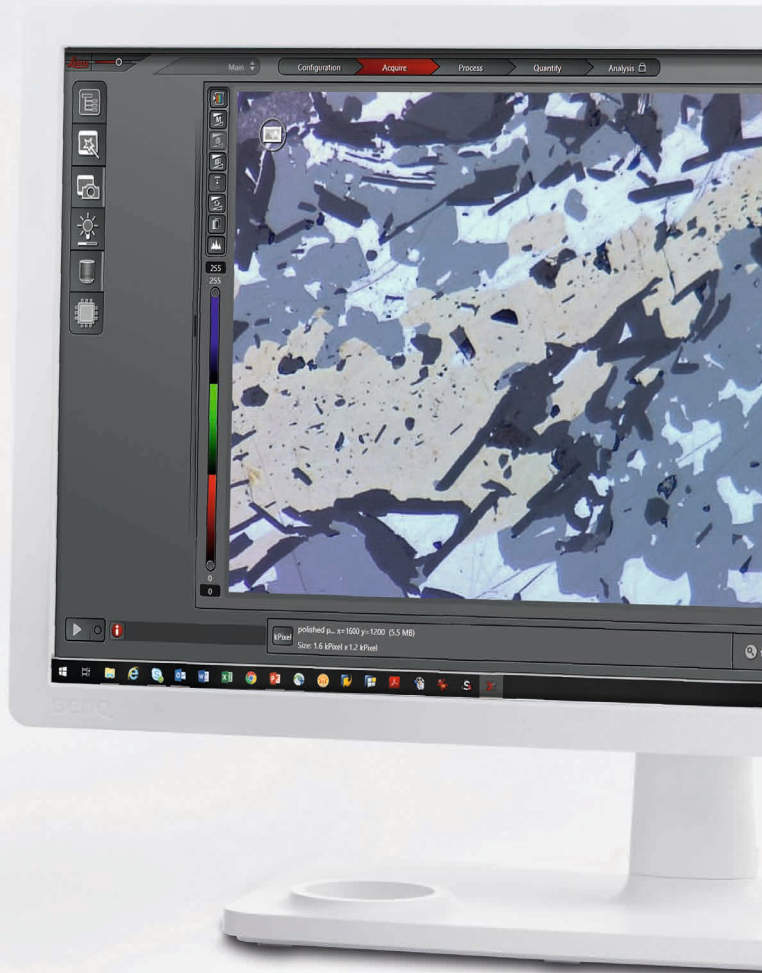

SPECIFICATIONS

STAND

Shape of the stand protects controls
 Stand construction – die-cast aluminum
 Adjustable Koehler field diaphragm (TL)
 Centerable and focusable condenser mount
 External fuses
 Knurled nosepieces
 5 V/1.5 A USB power supply

REFLECTED LIGHT AXIS

4-segment LED illumination for:
 Incident light brightfield
 Oblique contrast
 Polarization contrast
 Built-in adjustable aperture diaphragm
 Removable beam splitter to avoid false pleochroism

MEMBRANE KEYBOARD CONTROL

3 LED segment control for selection and rotation of illumination direction
 LED-light intensity
 Power on/off switch

POLARIZER/ANALYZER SLOT FOR POLARIZED LIGHT

TRANSMITTED LIGHT

Built-in LED illumination – 25,000 hours service lifetime
 Full Koehler field diaphragm (with condensor)
 Optional Abbe condensor (NA 0.9)
 Continuous intensity adjustment
 2 hours auto off (can be disabled or enabled)

EYEPIECES

High eyepoint
 10×/20 (20 mm field of view)
 Crosshair eyepiece with 45° marks, scale, and orientation feature
 Available fixed or focusing
 Focusing eyepieces with reticule holder for 24.5 mm reticule
 Foldable eyeguards
 30 mm mounting diameter
 Other eyepiece magnification factors also available

STAGE

Integrated coaxial drive for X/Y movement
 Stage surface 185 mm (150 mm front) × 140 mm (W × D)
 Stages prepared to take special sample holders (stage wells)
 Rounded stage edges
 Non-extending rack
 Vernier for X/Y coordinates
 Wear-resistant stage surface

SPECIAL SAMPLE HOLDERS FOR EMBEDDED METALLOGRAPHIC SALES (STAGE WELLS)

Stage well for one inch samples
 Stage well for maximum sample height = 30 mm

OBJECTIVES

Infinity platform
 HI PLAN or N PLAN series
 Objective labeling laser engraved
 M25 nosepiece thread

FOCUS

Low position focus controls
 Self-adjusting focus mechanism
 300 microns per fine focus rotation
 Calibrated in 3 micron increments
 Weighted focus knobs

IMAGING

Trinocular tubes available (50% / 50% light split)
 C-mount adapters with standard Leica Microsystems mount
 Leica cameras

EZSTORE™

Vertical handle
 Undercut in front of stand
 Cord wrap
 Vertical cord attachment to stand

AGTREAT™

Anti-microbial surfaces

CERTIFICATIONS

cULus, CE, RoHS

RECOMMENDED OUTFITS

Leica DM750 M with 4-position nosepiece for reflected & oblique light including industrial stage & stage wells

STAND		Quantity
13 613 115	Leica DM750 M with 4-position nosepiece	1
TUBES		
13 613 521	30° binocular tube	1
EYEPIECES		
13 613 532	10×/20 focusing eyepiece with eyeguard	1
13 613 530	10×/20 eyepiece with eyeguard	1
ILLUMINATION		
13 613 171	Incident light axis with LED illumination	1
STAGE WELL PLATES		
13 613 167	Stage well for small diameter samples	1
13 613 168	Stage well for large diameter samples	1
OBJECTIVES		
11 566 071	Objective HI PLAN EPI 5×/0.12	1
11 566 069	Objective HI PLAN EPI 10×/0.25	1
11 566 070	Objective HI PLAN EPI 20×/0.40	1
11 566 072	Objective N PLAN EPI 50×/0.75	1
POWER CORD	NOT INCLUDED: Must be ordered separately	1

Leica DM750 M with 5-position nosepiece for RL, TL, oblique & polarized light including industrial stage & stage wells, Leica DMC2900

STAND		Quantity
13 613 117	Leica DM750 M with 5-position nosepiece & industrial stage (right hand)	1
TUBES / MOUNT / CAMERA		
13 613 523	30° Trinocular tube	1
13 613 706	C-mount 0.55×	1
12 730 466	Leica DMC2900 camera	1
EYEPIECES		
13 613 532	10×/20 focusing eyepiece with eyeguard	1
13 613 530	10×/20 eyepiece with eyeguard	1
ILLUMINATION		
13 613 172	Reflected light illuminator kit LED (RL-Axis, polarizer & analyzer)	1
STAGE WELL PLATES		
13 613 167	Stage well for small diameter samples	1
13 613 168	Stage well for large diameter samples	1
13 613 550	Abbe condensor	1
OBJECTIVES		
11 566 071	Objective HI PLAN EPI 5×/0.12	1
11 566 069	Objective HI PLAN EPI 10×/0.25	1
11 566 070	Objective HI PLAN EPI 20×/0.40	1
11 566 072	Objective N PLAN EPI 50×/0.75	1
11 566 073	Objective N PLAN EPI 100×/0.75	1
POWER CORD	NOT INCLUDED: Must be ordered separately	1

DIMENSIONS

Dimensions in mm

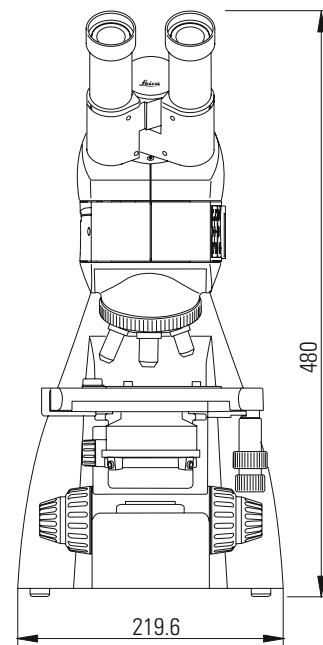
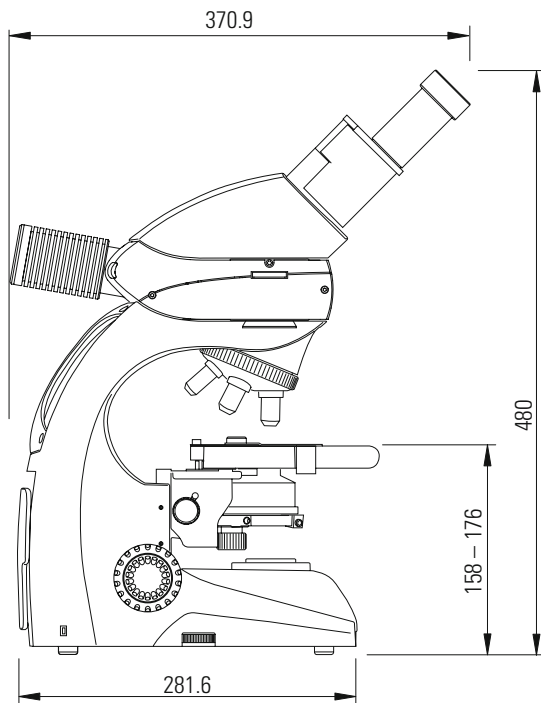

SYSTEM DIAGRAM

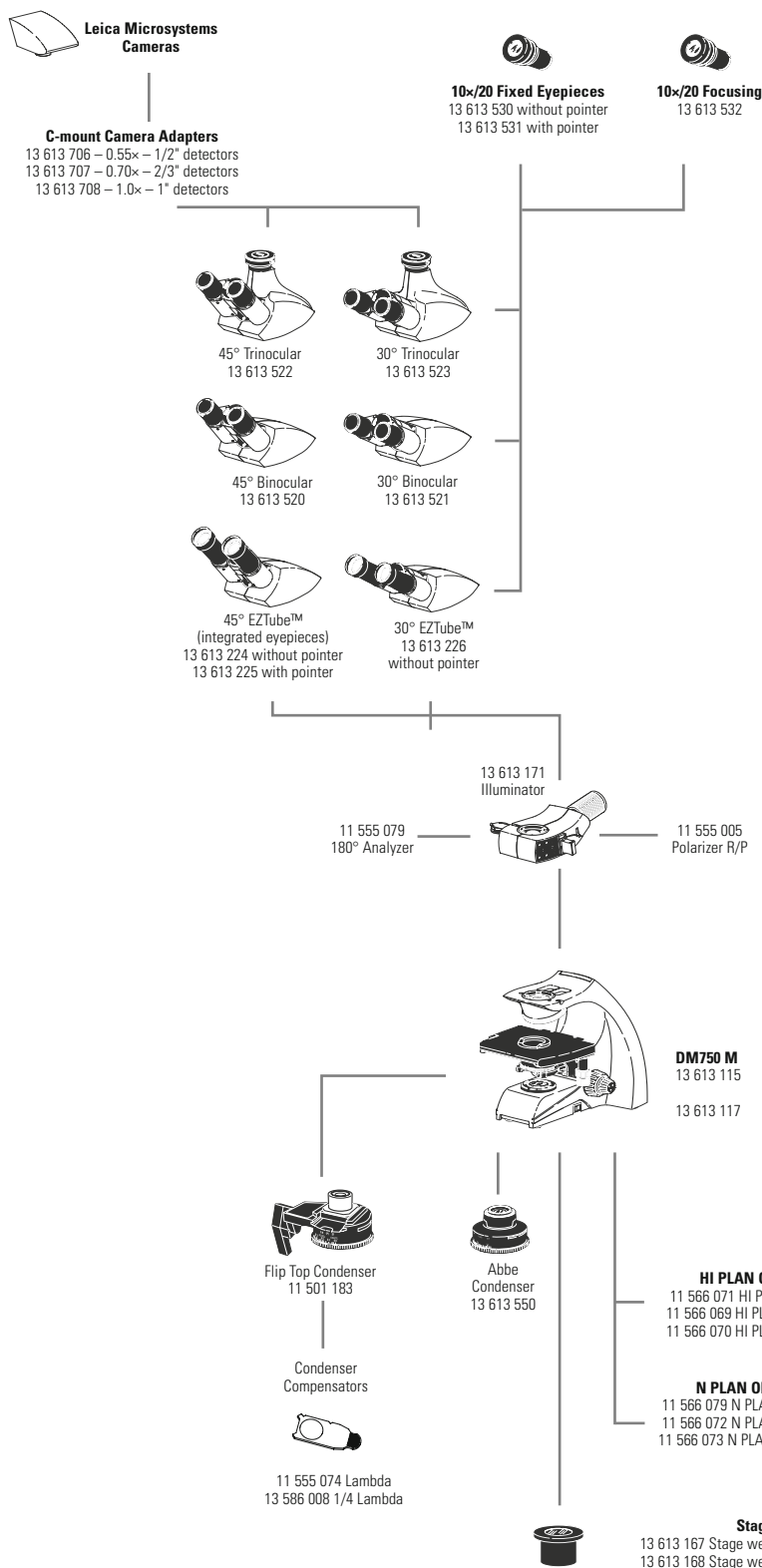

Additional Polarizer Sliders for Reflected Light

- 11 565 001 Polarizer with lambda plate
- 11 555 084 Polarizer 360° rotatable

Analyzer Sliders

- 11 555 045 Fixed analyzer slider
- 11 555 079 180° rotatable analyzer slider
- 11 555 080 360° rotatable analyzer slider

Stage Well

- 13 613 167 Stage well for one inch samples
- 13 613 168 Stage well for Ø 30 mm samples

Replacements

- 13 613 563 Eyeguard pair
- 13302138946910 Fuse
- 13 613 100-100 Leica DM750 M user documents
- 13 586 062 Add-on lens for condensers (included with stand)
- 13 613 669 Dust cover

Others

- 11 513 106 Stage micrometer
- 11 505 091 Diffuser slider for using 2.5x objective with Abbe condensers
- 11 505 507 Auxiliary lens for using 2.5x objective with 11 501 183 flip top condenser

International Power Cords

- 13 613 900 U.S. 
- 13 613 901 Europe Continental 
- 13 613 902 U.K. 
- 13 613 903 Switzerland 
- 13 613 904 Denmark 
- 13 613 905 Italy 
- 13 613 906 Australia 
- 13 613 907 China 
- 13 613 908 Japan 
- 13 613 909 Israel 
- 13 613 910 South Africa 
- 13 613 911 India 
- 13 613 912 Argentina 

CLEAN AND GREEN



WE ACTIVELY IMPLEMENT WAYS TO MAKE OUR ENVIRONMENT
CLEANER AND SAFER FOR THIS GENERATION AND THE NEXT

SEE MORE AT WWW.LEICA-MICROSYSTEMS.COM/EDUCATION

-
- › No lead content in any of the glass components.
 - › Constantly optimizing our logistics chain keeps the CO₂ footprint as low as possible.
 - › AgTreat™ helps prevent the spread of disease via microscope surfaces and leads to a healthier laboratory environment.
 - › All products have been tested by independent safety laboratories and carry the cULus and CE mark to indicate their design for safety.
 - › All products are RoHs compliant, which means all electrical components meet restrictions on the use of hazardous substances.
- › Interactive tour for Earth and Material Science courses
 - › E-Series stereomicroscopes for low magnification inspection, dissecting, and image capture
 - › Leica DM500 and Leica DM750 for Life Science Education
 - › Selection of higher level microscopes for research
 - › A selection of posters and instructional booklets, which are free of charge

CONNECT
WITH US!

