



**Code Shooter with AFR, Belt Temp, & Boost for RZR Turbo/S**  
**SKU(s): AFR (709FP0020, Belt (709FC0014)**

**INCLUDED PARTS**

(1) AFR Module with Hardware
(1) Belt Temp Module with Hardware
(1) Polaris Diagnostic Port Replicator
(1) Can Am to Belt Temp Cable
(1) Code Shooter to RJ45 Cable
(1) Can Am to CAN Lambda Cable

**REQUIRED TOOLS**

Unibit (Step Bit) 1 1/4"
1/2" Drill Bit
Push Dart Tool
T-40 Torx Socket
Sider Cutters
Welder (02 Bung)
Loctite/ Anti-Seize/ Silicone
Velcro
Rubber Gromet (1-1/4")
Zip Ties



**DIAGNOSTIC PORT  
REPLICATOR**



**AFR MODULE**



**RAZORBACK BELT  
TEMP MODULE**



**PNP AFR  
HARNESS**



**NOTE:** The EVP Code Shooter App allows you to display live data of Air/Fuel Ratio, Belt Temperature and Boost on your mobile device. Optionally, you can pick and choose to purchase these modules for Air/Fuel Ratio and Belt Temperature. Boost is measured of the Map sensor and your plenum will always have a Map sensor(s). These instructions will show you how to locate your OBD port, install Code Shooter, AFR module, and Belt Temperature module. If you have not purchased all the modules you can skip through the instructions to the correct module you purchased.

**NOTE:** We recommend mounting these modules in a clean, water resistant area. We installed these modules in a 2 seat RZR Turbo/S and mounted the modules in the glove box. The customer can decide where they want to mount the modules whether its in the glove box or an accessory bag. These modules are NOT waterproof.

### ***Instructions for Boost:***

A benefit to Code Shooter is the device reads right off your vehicles ECU. No additional hardware or modules are needed for reading boost with Code Shooter. Since the vehicle already reads boost off the Map sensor(s) in the plenum, with code shooter and your mobile device you can read live data coming from your vehicles ECU. Make sure your Code Shooter is plugged into the diagnostic port and paired with your mobile device.

### ***Instructions for AFR Module***

**Step 1:** Remove both passenger and driver captain's chairs.

**Step 2:** Remove the rear firewall access panel to the turbo.

**Step 3:** Remove the center console by removing (4) push darts and (3) T-40 Torx. Push the shifter and seat belt rubber boots down into the center console. They will stay with the vehicle. (Figure 1)

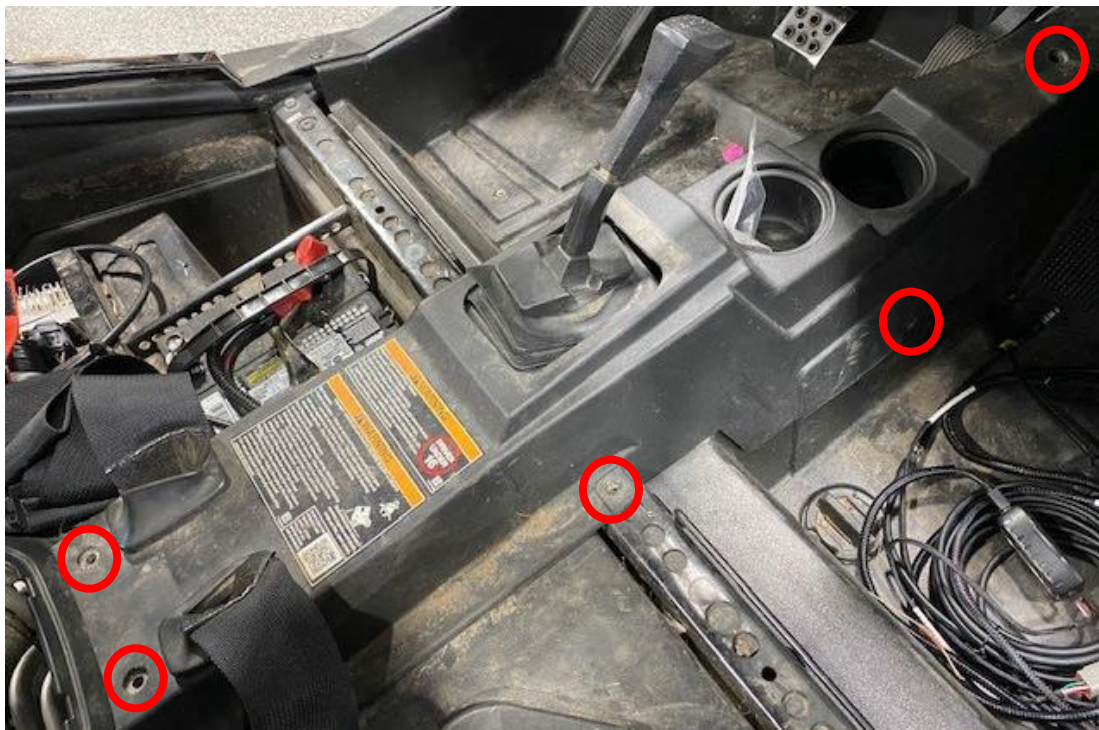

Figure 1

**Step 4:** Remove the center console, you will have to finesse the shifter around to fully remove the console. Place the console in the driver's side floorboard.

**Step 5:** On the front of the vehicle, you will find a hood, remove the hood and locate the Diagnostic port. The diagnostic port will be an 8-pin port with a purple internal clip. On the firewall you will see (2) rubber gromets, pop the smaller gromet out on the left. (See figure 2)

Polaris Diagnostic Plug

Rubber Gromet pulled out of the firewall.



Figure 2



**Step 6:** Locate the glove box, we will need to drill a 1 1/4" hole. To keep the wires and harness's hidden, we drilled our hole towards the left rear of the glove box. (See figures 3-4)



Figure 3, Inside the glove box.



Figure 4, Underneath the glove box.

**Step 7:** Grab the supplied diagnostic triple Indy wiring harness, feed the Polaris male (2 ft end) from the glove box through the front firewall and rubber gromet. Plug it into the vehicle diagnostic port. The triple Indy part of the plug will stay in the glove box.

**Step 8:** Grab the supplied O2 sensor and put anti seize on the threads. **NOTE:** Do not put anything on the tip of the sensor. (Figure 5)

**NOTE:** IF you do NOT have an auxiliary O2 bung located on your exhaust, please read our **"Auxiliary O2 Bung Instructions"**

**Step 9:** With a 19mm wrench, remove the auxiliary O2 sensor bung plug. Install the O2 sensor into the bung, tighten down with a 22mm wrench.

**Step 10:** Grab the supplied AFR wiring harness and plug it into the tail of the O2 sensor. Route the wiring harness away from any heat source, rotating parts, and so it wont snag onto anything while riding. Run it through the rear firewall, underneath the center council supports, next to the shifter, and through the front firewall following the coolant lines. Run it up the front firewall, through the rubber gromet where the diagnostic port is, and down into the cab. Feed it into the glove box.



Figure 5

Once complete, start strapping it with zip ties from the rear to the front. You can keep the access length up front, under the hood. (Figure 6-7)



Figure 6, AFR Cable ran down the center console.



Figure 7, AFR Cable ran through the firewall into the cab.

**Step 11:** Plug the AFR wiring harness into the AFR module in the glovebox. From the AFR module plug in the grey adaptor to the triple Indy harness (the first or second grey plug). Cut the proper length Velcro and mount the module on the side of the glovebox.

### ***Instructions for Belt Temp Module:***

**Step 1:** If you have not already installed the AFR module, please see step 1-7 above underneath **AFR Module**. This is the same seven steps it takes to disassemble the car.

**Step 2:** Now that the center console is out, glove box is drilled out, and the Polaris diagnostic harness is plugged in, we can continue.

**Step 3:** First thing we need to mount the Belt Temperature sensor. Don't mount the sensor on the clutch cover, otherwise you need to remove it every time you need to maintenance your clutches. The RZR Turbo has a shelf in the middle of the clutch box, which makes the 12 o'clock position not very suitable for mounting. We mounted our Belt Temperature sensor in the 10 o'clock position. (See Figure 7)

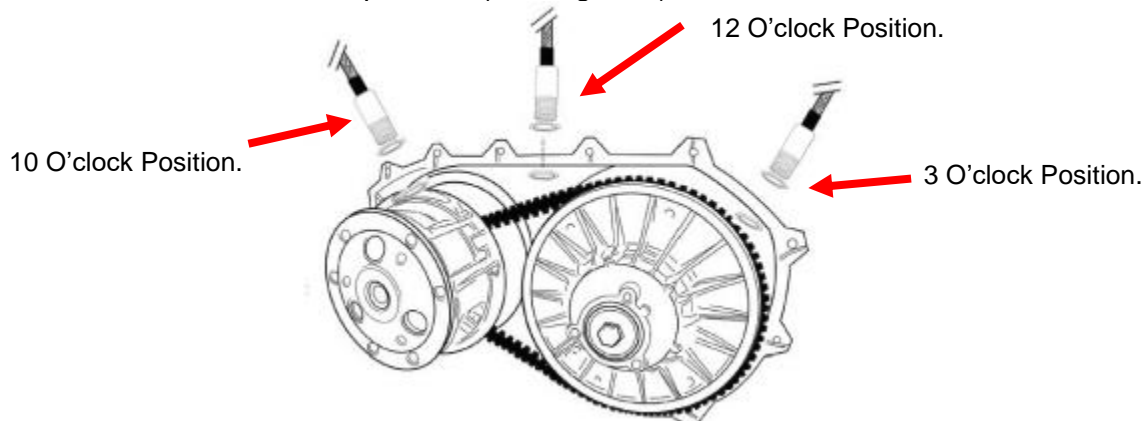

Figure 8

**Step 4:** With a hole punch or small diameter drill bit, start an indent on the clutch casing. **NOTE:** Make sure the belt sensor is directly in the middle of the belt. Once your indent is in the correct location, grab a 1/2" drill bit and drill the hole out. (Figure 8-9)



Figure 9,



Figure 10

**Step 5:** Blow the debris away with compressed air and make sure inside the belt box is clean.

**Step 6:** Grab the belt temperature sensor take both nuts off, apply a small amount of Teflon tape (since we are mount the sensor directly to the casting of the clutch box) place one nut on the backside and slide it through the hole. Apply a small amount of Loctite to the threads inside the clutch box. Tighten the second nut on, keep the nut and sensor flush with each other. You do not want the sensor protruding into the clutch box. Take (2) 14mm wrenches and tighten. (Figure 11)



Figure 11



**Step 7:** Connect the Belt Temperature wiring harness to the pig tail on the sensor, route the harness through the rear firewall, down center console by the shifter, through the front firewall following the coolant lines. Run it up the firewall and through the same rubber gromet where the diagnostic plug and AFR wiring harness did. Push it through the firewall into the cab and into the glovebox. (Figure 12-13)



All wiring harness's ran through the rubber gromet in the firewall.

AFR and Belt Temperature wiring harness ran down the center console.

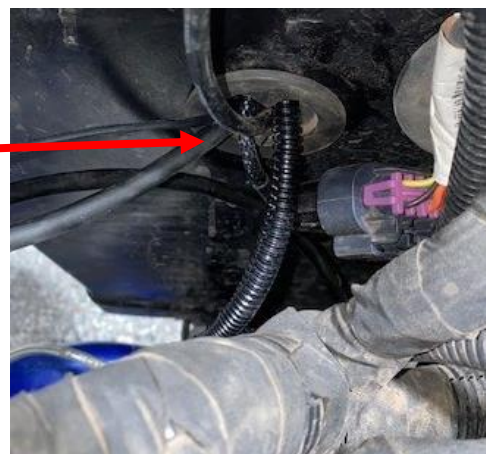
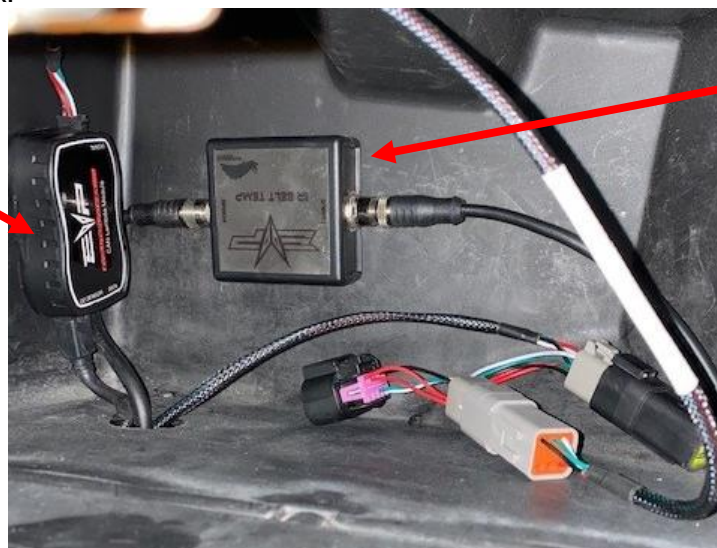

Figure 13

Figure 12

**Step 8:** With zip ties, start in the rear of the vehicle and strap the Belt Temperature wiring harness to the frame of the car, keeping the wiring harness away from heat sources and rotating parts.

**Step 9:** Connect the Belt Temperature module to the belt wiring harness in the glovebox. From the Belt Temperature module, plug in the grey adaptor to the triple Indy harness (the first or second grey plug). Cut the proper length Velcro and mount the module on the side of the glovebox.



AFR module

Belt Temperature module.

Figure 14

**Step 10:** If you would like to keep your glove box sealed, purchase a 1 1/4" rubber gromet and cut one end from the outside to the middle. Wrap the cables to the inside of the gromet and push it from the bottom of the glovebox in. Once the rubber gromet is seated, run a bead of clear silicone around the outside and middle of the gromet. This will help seal the glovebox.

### ***Reassembly of the Car:***

**Step 1:** Reassemble the center console, pull the seat belt boots and shifter boot till they are seated. Secure the center console with (3) T-40 Torx bolts and (4) push darts.

**Step 2:** Reassemble the turbo access panel on the rear of the firewall.

**Step 3:** Reassemble both driver and passenger seats.

**Step 4:** Reassemble the clutch cover.

**Step 5:** Zip tie any access wire underneath the front hood, reassemble the front hood.

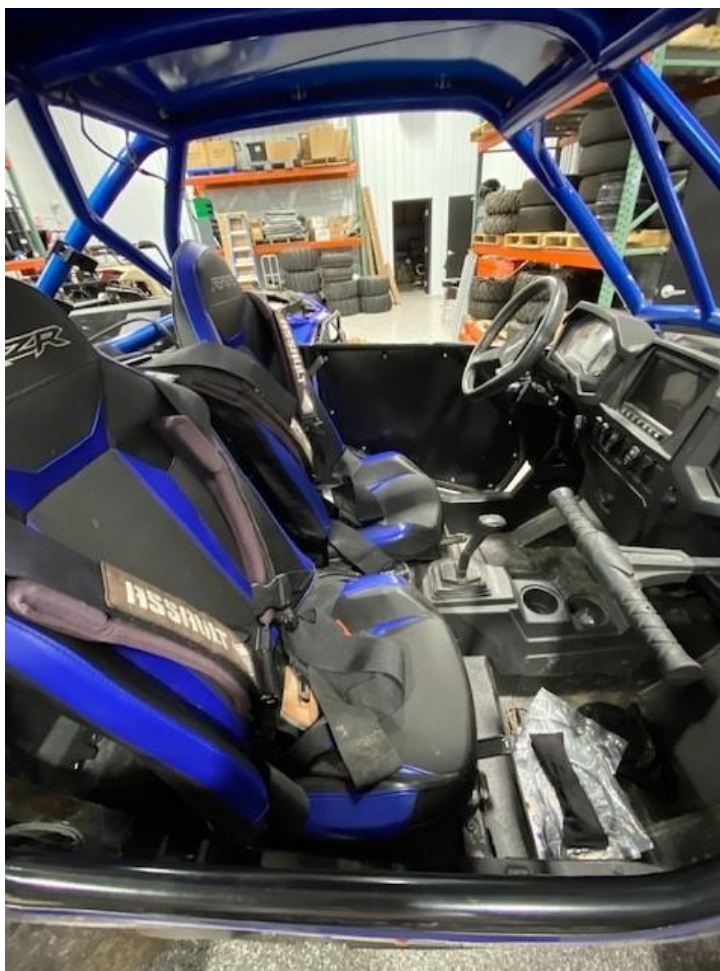





## INSTALLATION INSTRUCTIONS

Thank you for choosing Evolution Powersports products. If you require further assistance, please call our Tech Support @ (715) 247-3862

**Note:** This product is exempt from the emission standards and related requirements of 40 C.F.R. § 1051 as provided by 40 C.F.R. § 1051.620, and California law [e.g., vehicle code §§ 27156 and 38391]. This product is sold only for use in connection with EPA certified, purpose-built, nonroad vehicles used solely for closed course, nonroad competition/racing and not used for any recreational purpose or on public highways or right of ways maintained by and open to the public. This product is sold only in connection with machines that do not fall under state and/or federal noise or emission standards/regulations. Purchasers who/that purchase this product represent and warrant that the product is purchased only in connection with EPA -certified, emission-regulations-exempt and noise-regulations-exempt competition/racing vehicles as interpreted under applicable state and/or federal law. Questions: Call Evolution Powersports at (715) 247-3862.

WE'D LOVE TO HEAR FROM YOU - LEAVE A REVIEW & STAY CONNECTED!   