

# Romantic Aegean Sea

L906



L906 Instruction manual

## NOTICE OF ASSEMBLE

### Tips for assembling

1. Pictures shown on the package may be slightly different from the actual product.
2. All the materials are taken in the operation step, put the remaining materials back into the original pocket until the installation is completed. (Avoid material loss during installation)
3. The dimensions indicated in the step diagram are "cm".
4. If there have template paper material, please cut the material according to the template to avoid mistakes..
5. According to the part rule example at the bottom of this page, refer to the part on the part number drawing, find the material object and compare with the material list, confirm and install. (Wooden parts only)
6. Glue should not be applied too much, so as not to dry longer, overflow will affect the effect of the finished product.
7. Part shapes may differ from the photographs depending on the production batch

### Testing on LED function

Be sure to test the LED lights before making the lighting, note that the LED white wire to the negative, grey wire to the positive reference to the following figure operation test.

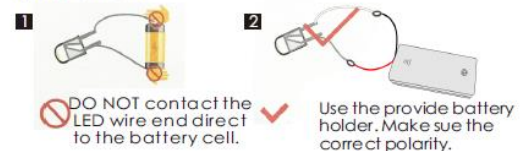

### How to assemble the battery holder

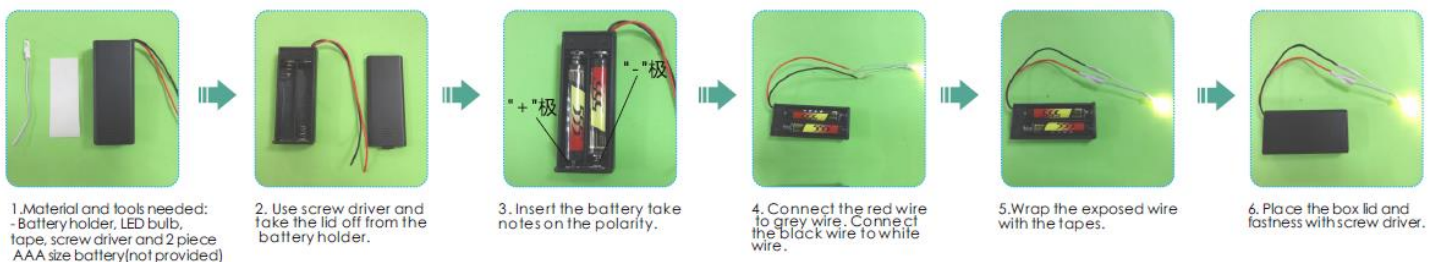

### Examples of parts rule:

Aa01: The parts are directly in the packaging box; B01: The parts are in the B bag; C01: The parts are in the C bag, and so on. (Note: The printing paper is displayed in the step A04-01: The printing paper is directly placed in the packaging (The part number is A04-01 in the box)



## details of miniature kit

Name	Material package
printing paper	B bag A-A04(All printing and template papers are shown on A04 paper, total 6 pieces A3)
cabinet	F bag + N bag + P bag + Q bag + printing paper
dining table and chair	F bag + N bag + P bag + Q bag + printing paper
little food cart	D bag + F bag + N bag + Q bag + printing paper
wall decoration	F bag + N bag + printing paper
sofa	G bag + N bag + Q bag + printing paper
table	G bag + N bag + printing paper
drawing	G bag + P bag + printing paper
rocking chair	G bag + N bag + printing paper
dog house	H bag + printing paper
bedside cabinet	H bag + P bag + Q bag + R bag + printing paper
slipper	H bag + P bag + N bag + printing paper
bed	H bag + N bag + printing paper
guitar	H bag + printing paper
bathroom	J bag + P bag + Q bag + printing paper
piano	F bag + J bag + printing paper
children's bed	K bag + Q bag + N bag + printing paper
chandelier	L bag + P bag + Q bag + R bag
bookcase	G bag + H bag + L bag + P bag + Q bag + printing paper
small table and chair	L bag + N bag + Q bag + printing paper
beach volleyball	L bag + P bag + N bag + printing paper
swimming pool	M bag + P bag
lookout tower	M bag + R bag + printing paper
boat	M bag + N bag + R bag + printing paper
potted plant	P bag + Q bag + printing paper
Trojan horse and slide plate	P bag + Q bag + S bag + printing paper
outer frame	A bag + B bag + C bag + D bag + E bag + N bag + P bag + Q bag + R bag + printing paper

Welcome to the little DIY world, now come with me

## Thumbnail of material list( reference only)

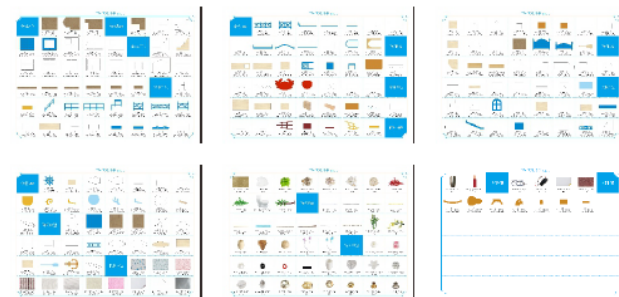

## Thumbnail of printing paper & template paper ( reference only)

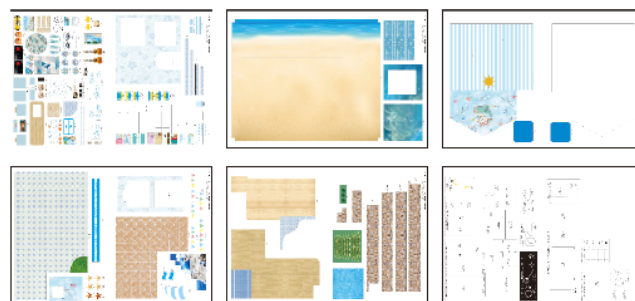

## Symbol description used

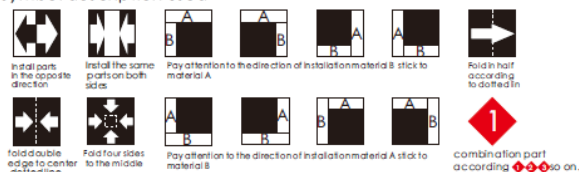

2

### Cabinet

Please cut out N07 according to the template paper before making.

F01, F02, F03 (2pieces), N07 (pan), N09  
 N11, N14, P01, Q05 (3pieces), Q15 (2pieces), Q16  
 Q17, A04-01, A04-02, A04-03, N11 wash basin  
 A04-04, A04-05, A04-06, A04-21

- 
- 
- 
- 
- 
- 
- 
- 
- 
- 
- 
- 
- 
- 
- 
- 
- 
- 
- 
- 
- 
- 
- 
- 
- 
- 
- 
- 
-

3



**30 Dining table and chair**

**31 electric cooker**

**3** need 4pieces

**4** F10 F07 F10 F08

**5** F10 F09

**6** F10 F08

**7** F09

**8** P08 45 cm

**9** P08

**10** P08

**11** P08

**12** N20

**13** F11 F12

**14** Q04

**15** N16 N15 N15

**16** N08(sushi 2) N07(sushi 1) need 3pieces

**17** Q13

**18** N15 Q12

**19** P01 1.2cm

**20** P01 Q10

**21** N12(plant 1)

**22** N12( plant 1)

**23** P12 N12(plant 1) Put an appropriate amount of P12 into N12 (plant 1)

**24** plant 1 A04-07

**25** plant 1 plant 2 plant 3 Refer to the above steps to complete the preparation of plant 2, plant 3 and retain for later use.

**Materials:** F04 (4pieces), F05 (4pieces), F06 (4pieces), F07, F08 (2pieces), F09 (2pieces), F10 (4pieces), F11, F12, N07(sushi1), N08(sushi2), N15 (3pieces), N12(plant 1), N16 (1piece), N20, P01, P08, P12, Q04 (2pieces), N12(plant 2), Q10, Q12, Q13, INSTC, HONG, A04-07, A04-08, A04-09, N12(plant 3)

4

**26** plant 2

**27**

**28** chair dining table chair chair chair

**little food cart**

**1** D17 F13 F14

**2** F13

**3** Q03

**4** Q10 N20

**5** A04-12 Q12

**6** Q20 A04-22

**7** Q20 Q12 Q10 A04-22

**Wall decoration**

Please cut out the N11 according to the template paper before making.

**1** N11 plant 4

**2** N11 plant 4

**3** N14 plant 4 A04-11 Put in an appropriate amount of N14

**4** A04-39 F15

**5** A04-26

**Materials:** D17, F13, F14, F15, N11 plant 4, N14, A04-11, A04-26, A04-39, Q03 (4pieces), Q10, Q12, A04-12, Q20, A04-22

**sofa**

Please cut out N02, N03, N04, N05, N07 according to the template paper before making.

**1** N04 sofa back cushion

**2** N04 sofa back cushion fold the four sides to the middle

**3** G01

**4** N07 sofa cushion G03

**5** N04 sofa cushion 2 G03 G03 face down with non-woven attached.

**6** G03 fold the four sides to the middle

**Materials:** G01, G02, G03 (2pieces), G04 (2pieces), G05 (2pieces), N07 sofa cushion, Q01 (4pieces), N13, N05 pillow 1, N02 pillow 2, N03 pillow 2, N03 pillow 3, N04 pillow 3, N04 sofa cushion 1, N04 sofa cushion 2, N04 sofa armrest 1, N04 sofa armrest 2, N04 sofa armrest 3

5



7 G03 need 2pieces	8 N04 sofa cushion 1 G02	9 G02 fold the four sides to the middle	10 G02	11 G05 G04	12 N04 sofa armrest 1
13 N04 sofa armrest 2	14 N04 sofa armrest 3	15	16 need 2pieces	17 G03 G03 G02	18 G01
19	20 Q01 Flip the sofa to the bottom	21 N05 pillow 1	22 N05 pillow 1 Folding in half	23 N05 pillow 1 Seal both sides of the red line with glue.	24 N05 pillow 1 N13 tuck in the right amount of cotton.
25 pillow 1 Seal the opening with glue.	26 All pillows are made in the same way. pillow 1 pillow 1 need 2pieces	27 pillow 1 pillow 1	28 N02 pillow 2 N03 pillow 2 Complete the pillow 2 according to the previous steps, and keep it for later use.	29 N03 pillow 3 N04 pillow 3 Complete the pillow 3 according to the previous steps, and keep it for later use.	
<b>Table</b>  G06 G07 G08 G09 A04-54 A04-58 N16 (1piece) G10 (3pieces)		1 G10 G08	2 1cm G10	3 G07	4 G09
		5 G06	6 A04-58	7 A04-58	

6

8 A04-58	9 All books are made in the same way. A04-58	10 A04-54 Complete the book according to the previous steps.	11 A04-58 A04-54	12 The previous steps have been made. plant 1 N16	
<b>Drawing</b>  G11 G12 G13 (2pieces) P01 A04-23 A04-14 A04-14 G12 G13 G11 A04-23	1 P01 1.4cm A04-23	3 G13	4 G11	5 G13	6 A04-23
	<b>Rocking Chair</b>  G14 (2pieces) G15 N04 (rocking chair) A04-53 Please cut out N04 according to the template paper before making.		1 N04 (rocking chair) G14	2 G14 G15	3 A04-53
<b>Dog House</b>  H01 H02 H03 H04 (2pieces) H05 H06 A04-10 A04-13	1 H04 H03	2 H03 H04	3 A04-10 H02	4 H02	
	5 H05 2.2cm H06	6 H06	7 turn A04-13 to the backside. H01 A04-13	8 H01 fold the four sides to the middle	9 H01

7



### Bedside table

1. Assemble H08 and H07.
2. Attach H09 to the side.
3. Attach H07 to the top.
4. Attach H07 to the front.
5. Attach A04-15 to the front.
6. When making, refer to the template of P01 wire bedroom light for bending. Length: 6cm.
7. Bend P01 wire. Dimensions: 3.5cm horizontal, 2.5cm vertical.
8. Bend P01 wire. Dimension: 1cm.
9. Attach A04-18 to the wire.
10. Attach P01 to the lampshade.
11. Attach Q01 to P13.
12. Attach A04-18 to the lampshade.
13. Attach A04-39 to the table.
14. Attach A04-25 to the table.
15. Attach R01 to the table.

### Slipper

Please cut out N02 and N04 according to the template paper before making.

1. Attach N04 slipper to H10.
2. Need 2 pieces.
3. Attach N02 slipper to H10. Need 2 pieces.
4. Attach A04-29 to the slipper.
5. When making, refer to the template of P01 wire slipper for bending. Length: 2.5cm.
6. Bend P01 wire. Dimension: 1.2cm.
7. Bend P01 wire. Dimension: 1.0cm.
8. Attach P01 to A04-30.
9. Attach P01 to the slipper. Need 2 pieces.

8

### Bed

Please cut out N05 and N07 according to the template paper before making.

1. Attach N07 (mattress) to H12.
2. Attach N05 (mattress 1) to H12. H12 face down with non-woven attached.
3. Fold the four sides to the middle.
4. Attach N01 to the mattress. Dimensions: 7.5cm vertical, 5.6cm horizontal.
5. Attach N01 to the mattress. Dimensions: 1.6cm vertical, 5.9cm horizontal.
6. Attach N01 to the mattress. Dimensions: 1.6cm vertical, 4.3cm horizontal.
7. Attach H12 to the mattress.
8. Attach H12 to the mattress.
9. Attach H11 to the mattress.
10. Attach H13 to the mattress.
11. Attach A04-59 to the mattress. Complete the book according to the previous steps.
12. Attach N02 pillow 2 and N03 pillow 2 to the mattress. The previous steps have been made.
13. Attach N03 pillow 2 and N02 pillow 2 to the mattress.

### Guitar

1. Attach H15 to A04-48.
2. Attach H15 to A04-48.

### Bathroom

1. Attach A04-17 to J01. Paste A04-17 on the three sides indicated by the red line.
2. Attach A04-16 to the shower.
3. Attach P04 to the shower.
4. Attach P04 to the shower. Dimensions: 1.1cm vertical, 3.6cm horizontal.
5. Attach P04 to the shower. Attach Q12 to the shower.
6. Attach P02 to the shower. When making, refer to the template of P02 wire handle for bending. Length: 2cm.
7. Attach P02 to the shower. Dimensions: 0.35cm vertical, 1.4cm horizontal.

### Piano

1. Attach A04-44 to J04.
2. Attach A04-45 to J07.
3. Attach A04-46 to J06.
4. Attach A04-19 to J04. Fold in half.
5. Attach A04-19 to J04. Fold in half again.

9

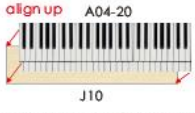

**5** align up A04-20  
  
 A04-20 is 2mm wider than J10.

**6**  
  
 paste the remaining printing paper on the side of the J10.

**7** Topview  

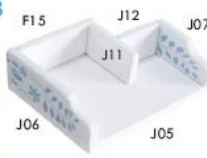

**8** F15 J12 J07  

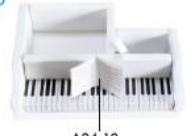

**9** J13  



**10**  
  
 A04-19

**11** J04  

**12** J08 J05 J08  
  
 turn the piano over to the bottom and paste J08.

**13** J14 J15  



**14** J15 J14  

**15**  



**Children's bed**

Please cut out N02 and N05 according to the template paper before making.

**7** N02 (bedsheets 2)  

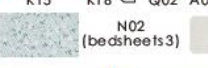

**8** N05 (mattress 2)  

**9** N02 (bedsheets 3)  

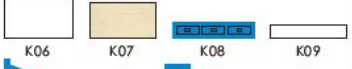

**10** N05 (mattress 3)  



**11** K01 K02 K03 K04 K05  

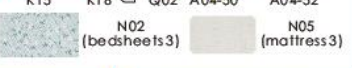

**12** K06 K07 K08 K09  



**13** K10 (2pieces) K11 (2pieces) K12 (3pieces) K13 (2pieces) K14 (2pieces) K15  



**14** Q02 A04-50 A04-52  



**1** A04-50 K03 K01  



**2** K04 K08  

**3** K04 K08  



**4** K02  

**5** N05 (mattress 2) K05  

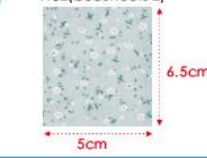

**6** K05  
  
 fold the four sides to the middle

**7** K05  

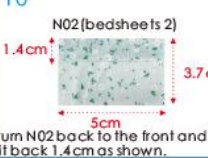

**8** N02 (bedsheets 2) 6.5cm 5cm  



**9** N02 (bedsheets 2) 1.4cm 5.1cm 5cm  
  
 flip N02 to the back and fold back 1.4cm as shown.

**10** N02 (bedsheets 2) 1.4cm 3.7cm 5cm  
  
 turn N02 back to the front and fold it back 1.4cm as shown.

**11** K05 N02 (bedsheets 2)  



**12** K05 N02 (bedsheets 2)  



**13**  

**14**  

**15** A04-52  
  
 Complete the bed according to the previous steps.

**16** N03 pillow 3 N04 pillow 3  
  
 The previous steps have been made.

**17** N04 pillow 3 N03 pillow 3 A04-52  



**18** K06  

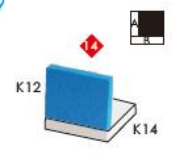

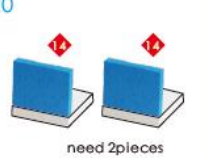
10

**19** K12 K14  



**20** K12 K14  
  
 need 2pieces

**21**  

**22**  



**23** K12  

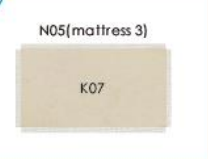

**24** K13  

**25** K16  



**26** K09  



**27** N05 (mattress 3) K07  

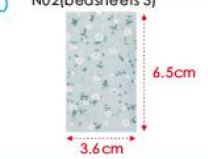

**28** K07  
  
 fold the four sides to the middle.

**29** K07  



**30** N02 (bedsheets 3) 6.5cm 3.6cm  



**31** N02 (bedsheets 3) 1.4cm 5.1cm 3.6cm  
  
 flip N02 to the back and fold back 1.4cm as shown.

**32** N02 (bedsheets 3) 1.4cm 3.7cm 3.6cm  
  
 turn N02 back to the front and fold it back 1.4cm as shown.

**33** K07 N02 (bedsheets 3)  



**34** K07 N02 (bedsheets 3)  

**35**  



**36**  

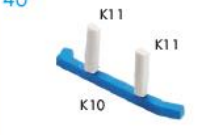

**37** The previous steps have been made.  
 N03 pillow 3 N04 pillow 3  

**38** N03 pillow 3 N04 pillow 3  

**39** K15  

**40** K10 K11  

**41** K10  

**42** Q02  



**Chandelier**

Chandelier No.1  
 Chandelier No.2 (3pieces)  
 Chandelier No.3 (2pieces)

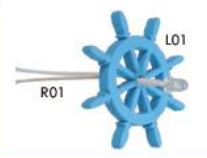
L01 Q07 (2pieces) Q08 (3pieces) Q09 (2pieces) Q11 (8pieces) P05 P10 R01 (6pieces)

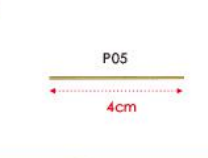
**1** L01 R01  



**2** P05 4cm  



**3** P05 Q11  

**4** P05 Q11  
  
 turn and tighten the wire.

**5** P05 Q11  















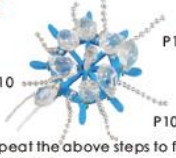





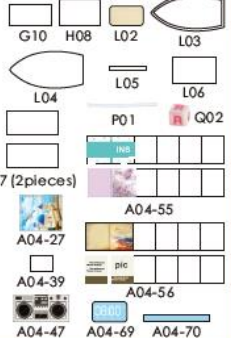

**6** need 8pieces  



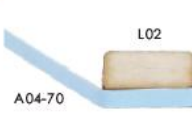
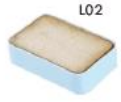









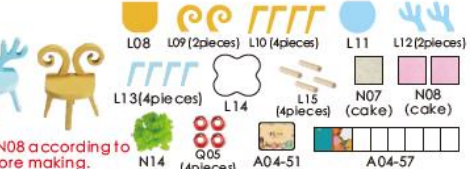

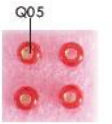
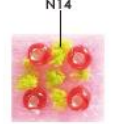









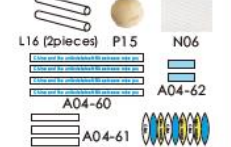



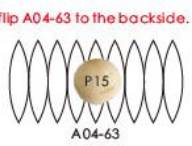

**7** L01  
  
 tighten the wire and fix on the L01 as shown.

**8**  
  
 repeat the above steps to fix 8 groups

11

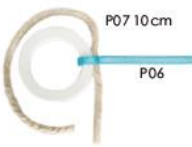

<p>9</p>  <p>P10 2.4cm</p>	<p>10</p>  <p>P10 cut 8 pieces</p>	<p>11</p>  <p>P10</p>	<p>12</p>  <p>P10 repeat the above steps to fix 8 groups</p>	<p>13</p>  <p>Chandelier No.1</p>	<p>14</p>  <p>Q08 R01</p>
<p>15</p>  <p>Chandelier No.2 need 3 pieces</p>	<p>16</p>  <p>Q09 R01</p>	<p>17</p>  <p>Q07</p>	<p>18</p>  <p>Chandelier No.3 need 2 pieces</p>		
<p>Bookcase</p> 	 <p>G10 H08 L02 L03 L04 L05 L06 P01 Q02 .07 (2 pieces) A04-27 A04-55 A04-39 pic A04-56 A04-47 A04-69 A04-70</p>	<p>1</p>  <p>A04-47 G10</p>	<p>2</p> <p>When making, refer to the template of P01 wire radio for bending.</p>  <p>P01 1.6cm</p>	<p>3</p>  <p>P01 0.35cm 1.2cm</p>	<p>4</p>  <p>radio P01 G10</p>
		<p>5</p>  <p>A04-70 L02</p>	<p>6</p>  <p>L02</p>	<p>7</p>  <p>A04-69 L02</p>	<p>8</p>  <p>A04-56 pic A04-55 Complete the book according to the previous steps.</p>
<p>9</p>  <p>L05 H08 L07 L07 L06 L04 particles are spaced 1.3cm apart.</p>		<p>11</p>  <p>L02 Q02 A04-55 A04-56 收音机</p>		<p>12</p>  <p>A04-27</p>	
<p>10</p>  <p>L03</p>					

<p>Small table and chair</p>  <p>Please cut out N07 and N08 according to the template paper before making.</p>	 <p>L08 L09 (2 pieces) L10 (4 pieces) L11 L12 (2 pieces) L13 (4 pieces) L14 L15 (4 pieces) N07 (cake) N08 (cake) N14 Q05 (4 pieces) A04-51 A04-57</p>	<p>12</p>  <p>N08 cake N07 cake two pieces of N08 sandwiched by a piece of N07 as shown.</p>	<p>2</p>  <p>Q05</p>	<p>3</p>  <p>N14</p>	
<p>4</p>  <p>A04-51 cake</p>	<p>5</p>  <p>A04-57 Complete the book according to the previous steps.</p>	<p>6</p>  <p>L10 L08</p>	<p>7</p>  <p>L09</p>	<p>8</p>  <p>L13 L11</p>	<p>9</p>  <p>L12</p>
<p>10</p>  <p>L15 L14</p>	<p>11</p>  <p>plant 3 The previous steps have been made. A04-57</p>	<p>12</p> 			
<p>Beach Volleyball</p> 	 <p>L16 (2 pieces) P15 N06 A04-60 A04-62 A04-61 A04-63</p>	<p>1</p>  <p>N06 2.4cm 4.6cm</p>	<p>2</p>  <p>A04-60 A04-61</p>	<p>3</p>  <p>flip the top image to the back.</p>	<p>4</p>  <p>A04-60 A04-61 Paste A04-60 and A04-61 on the other side.</p>
<p>5</p>  <p>A04-62 L16</p>	<p>6</p>  <p>need 2 pieces.</p>	<p>7</p>  <p>L16 L16</p>	<p>8</p>  <p>flip A04-63 to the backside. P15 A04-63</p>	<p>9</p>  <p>P15 wrap up.</p>	
<p>Swimming pool</p> 	 <p>M01 P02 P06 P07</p>	<p>1</p>  <p>P07 10cm P06</p>	<p>2</p> 	<p>3</p>  <p>P06</p>	<p>4</p> 

**swimming ring**

5 6 7 8 9 10 need 2pieces

**Lookouttower**

1 2 3 4 5 6 7 8 9 10 11 12 13 14 15 16 17 18 19 20 turn it to the back and fix the wire as shown.

14

**Boat**

1 2 3 4 5 6 7 8 9 10 flip to the backside and fix the wire as shown.

**Potted plant**

1 2 3 4 5 6 7 8 trim the area below the red line. 9 10 trim the area below the red line. 11 cut it in the middle, one in two. 12 13 need 3pieces

15



**Trojan horse and Slide plate**

S01 (2pieces) S02 S03 (2pieces) S04 S05  
 S06 (2pieces) S07 (2pieces) P01 Q03 (4pieces)  
 A04-24

1 S01 S07 1.8cm  
 2 S01  
 3 S03 S03  
 4 S02  
 5 S05 S04  
 6 P01 1cm  
 7 Q03 Q03 P01  
 8 need 2 pieces  
 9 A04-24 backside A04-24  
 10

1 Outer frame D14 D13  
 2 need 5 pieces  
 3 C01  
 4 C01  
 5 C02  
 6 D12  
 7 D11  
 8 D10  
 9 A04-89  
 10 D15 D13  
 11 D15  
 12 D15  
 13 A04-99 A04-97  
 14 D03  
 15 D04  
 16 D05  
 17 D06  
 18 D03 **Stairs 1**

16

19 D17 1.46cm 0.9cm D17 0.9cm D16  
 20 D16 **stairs 2**  
 21 D02 D02 D01  
 22 D01 **stairs 3**  
 23 A04-37 C09 A04-35 A04-36 A04-74  
 24 C09 C10  
 25 **top view** C15 C12 C15 C13 A03 C14 C16 C11  
 26 A03 C13 C11  
 27 C14 C16  
 28 C15 C12  
 29 C15  
 30 A04-101 paste A04-101 on the three sides indicated by the red line.  
 31 A04-102  
 32 A04-103  
 33 A04-100  
 34 A04-80  
 35 **turn A04-71 to the backside** A01 A04-71  
 36 A01 A04-71 fold the four sides to the middle.  
 37 A01  
 38 A04-76 A02  
 39 **Music machine core manual guide**  
 (if you have purchased the music machine core, please fix it firstly)  
 T01 Music machine core 1 piece  
 T02 Music machine core handle 1 piece  
 T03 Screw 3 pieces  
 A02  
 40 **T02 is left behind for installation.** A02 T03 T03  
 41 A04-64 B06  
 42 C04 C05

17





18



19





20



21



<p>148</p> <p>Pass the light wire from the boat through E02.</p> <p>E02</p>	<p>149</p> <p>A04-83 N15 N16</p>	<p>150</p> <p>R01</p> <p>Paste the lamp wire as shown in the figure.</p>	<p>151</p> <p>R01</p> <p>Paste the lamp wire as shown in the figure.</p>	<p>152</p> <p>N22</p>	
<p>153</p> <p>N22</p>	<p>154</p> <p>N18</p>	<p>155</p> <p>N20</p>	<p>How to assemble the battery holder</p> <p>Statement: the lamp wires cannot be inserted into the output socket.</p> <ul style="list-style-type: none"> <li>- Can use 7 batteries</li> <li>- Please notice the place of anode and cathode when put in the batteries</li> <li>- Rechargeable batteries are not blunt electrically</li> <li>- Rechargeable batteries can only be charged under adult supervision</li> <li>- Rechargeable batteries should be removed from the toy before charging</li> <li>- Different types of batteries cannot mix</li> <li>- Do not mix new batteries in use with semi-used batteries.</li> <li>- Run out of battery should be removed from the toy</li> <li>- The power shall not be short circuit</li> </ul>		<p>156</p> <p>A02</p>
<p>157</p> <p>Trim all the LED wiring to the same length.</p>	<p>158</p> <p>R03</p> <p>Twist the same color wire together.</p>	<p>159</p> <p>Use a craft blade to carefully skim over the plastic to bare the copper wire.</p>	<p>160</p> <p>Twist the same color wire together.</p>	<p>Paste the lamp traces behind A02 as shown and center them at the bottom.</p>	
<p>161</p> <p>R02</p> <p>3. Twist the following wire together:        (I) BLACK wire from the battery box with the WHITE wire from LED bulb.        (II) RED wire from the battery box with the GREY wire from LED bulb.</p> <p>R02 R03</p> <p>Roll and seal the duly twist copper with the white tape R03 provided.</p>	<p>162</p> <p>A04-78</p> <p>Place the battery box in the allocated space.</p>	<p>163</p> <p>A04-78</p>	<p>164</p> <p>T02</p>		

## Installation of dust cover

dust cover  
(Upgrade version accessories need to be purchased separately)

<p>ratio:1:12 T04 plexiglass (transparent) 30*24.5*0.18(1piece)</p>	<p>ratio:1:12 T05 plexiglass (transparent) 30*28*0.18(2pieces)</p>	<p>ratio:1:12 T06 plexiglass (transparent) 28*24.14*0.18(2pieces)</p>	<p>1</p> <p>stick T05 and T06 on T04</p>	<p>2</p> <p>stick five pieces of plexiglass dust cover as shown</p>	<p>3</p> <p>Ripped one side of kraft paper, leaving one side of kraft paper</p> <p>Take out the plexiglass and tear off the kraft paper with text on each piece of plexiglass</p>
<p>4</p> <p>The kraft paper that has been ripped off faces inward, and the kraft paper that has not been ripped off faces outward.</p>	<p>5</p> <p>Use R03 to fix the junction of two pieces of plexiglass. (use transparent tape to replace R03)</p>	<p>6</p> <p>The junction of every two pieces of plexiglass needs to be fixed with R03 (to prevent the plexiglass falling off)</p>	<p>7</p> <p>stick appropriate amount of glue to the interface of the two pieces of glass and scrape it slightly to make the glue penetrate into the junction of the two pieces of glass (the red line is the plexiglass interface)</p>	<p>8</p> <p>The junction of two pieces of plexiglass needs to be fixed with R03 (to prevent the plexiglass falling off)</p>	
<p>9</p> <p>stick appropriate amount of glue to the interface of the two pieces of glass and scrape it slightly to make the glue penetrate into the junction of the two pieces of glass (the red line is the plexiglass interface)</p>	<p>10</p> <p>The junction of two pieces of plexiglass needs to be fixed with R03 (to prevent the plexiglass falling off)</p>	<p>11</p> <p>stick appropriate amount of glue to the interface of the two pieces of glass and scrape it slightly to make the glue penetrate into the junction of the two pieces of glass (the red line is the plexiglass interface)</p>	<p>12</p> <p>the dust cover need to be glued 8 interfaces</p>	<p>13</p> <p>Leave it for 1 hour. After the glue dries out, tear off a layer of kraft paper outside the plexiglass</p>	

The instruction manual should be kept, after assembled