



# Pink Dream

Wall Lamp Bed Wall Self Light Cabinet Wall painting



Dresser Chair Book basket Small sofa Big sofa Tea table Piano Plant

**Instruction:**  
The colored picture on the outer packing is accomplished rendering for reference. Please prepare with knife, ruler, scissors, pencil, eraser and needle by yourself. The abrasive paper in the bag is for you to polish the angles of the wood. Please open the bags in order so that you can accomplish your work better. Please consult the corresponding flow chart on the reference in the producing process.

#### Tips and techniques:

1. Before commencing, do go through briefly on the user manual to get an overall idea.
2. Do use the provided sand paper to smoothen the wooden parts which is rough and uneven.
3. Please take note that all materials that provided is more than sufficient, however, try measuring the minimum length required, to avoid shortage of material before completing the project.
4. For young children, adults guidance is required, as during the project, sharp objects are being used.



13818

# Pink Dream



# Pink Dream

Outer frame

Parts' Name	Code	Material Name	Color	Thickness	Width	Length	Quantity
Outer frame	A01	Machine board	White	0.5	18	30	1
	A02	Machine board	Burly Wood	0.5	15	30	1
	A03	Machine board	White	0.5	15	30	1
	A04	Machine board	White	0.5	15	15	2
	A05	Machine board	Burly Wood	0.5	14	15	1
	A06	Frame	White		19	33.3	1
	A07	Organic glass	Transparent		18	30	1
	A08	Doll lovers					1pair
	A09	Music machine core					1pair
	A10	Glue					1
	A11	Print paper					1
	A12	Instruction					1

\* Paste the material from A01 to A11 to the good parts according to the following tips. Before making, cut the window hole of A01 into right angle. (As shown in figure)

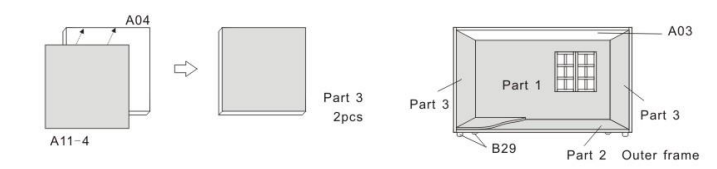
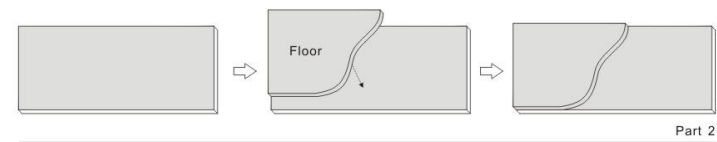
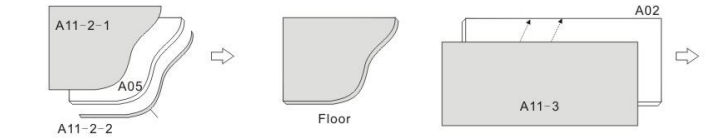
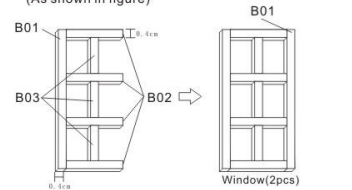

1

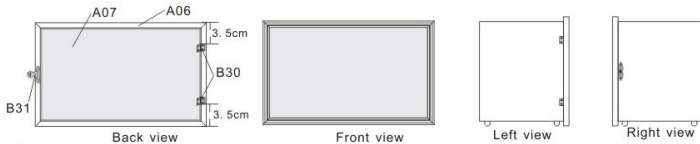

\* Install the music core of A09 onto the back of the out frame according to the following tips, and fix it onto the out frame.



Bag B material with working instructions

Parts' Name	Code	Material Name	Color	Thickness	Width	Length	Quantity	
Window	B01	Wood	White	0.4	0.5	9	4	
	B02	Wood	White	0.4	0.5	3.2	8	
	B03	Wood	White	0.4	0.5	2.4	6	
	B04	Wood	White	0.2	0.5	8.5	1	
Piano	B05	Wood	White	0.2	1.7	7.2	1	
	B06	Wood	White	1.5	5.7	6.9	1	
	B07	Wood grain	White	0.2	1.2	1.2	2	
	B08	Wood	White	0.5	1	6.1	1	
	B09	Wood	White	0.2	0.3	6.1	1	
	B10	Wood	White	0.2	0.6	6.5	1	
	B11	Wood grain	White	0.2	1	2.3	1	
	B12	Round wooden grain	White	φ=0.3		2.4	2	
	B13	Wood	White	0.3	0.5	1.5	2	
	Piano etc	B14	Wood	White	0.2	1.5	3.3	1
		B15	Wood	White	0.3	0.4	1.6	4
		B16	Wood grain	White	0.2	0.5	2.6	2
		B17	Wood grain	White	0.5	0.5	0.9	2
B18		Wood grain	White	0.2	3	8.5	1	
B19		Wood grain	White	0.2	3.2	8.5	1	
B20		Wood grain	White	0.2	3	3	1	
B21		Wood grain	White	0.2	2.6	2.6	1	
Corner shelf	B22	Wood grain	White	0.2	2.1	2.1	1	
	B23	Wood grain	White	0.2	1.7	1.7	1	
	B24	Wood	White	0.2	1.2	4.6	1	
	B25	Wood grain	White	0.2	0.8	1.5	2	
	B26	Wood	White	0.15	0.5	4.5	1	
Wall shelf	B27	Wood	White	0.2	1.5	1.5	1	
	B28	Wood	White	0.15	0.5	4.5	1	

Curtain

\* Cut the B43 into 10\*5.5cm two parts, and cut the tail of B37 into 0.8\*7.5 two parts, and paste them to B04, then the curtain is finished.

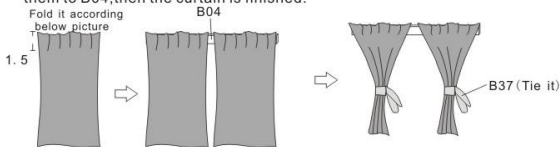

Piano

\* Paste the body of the piano using B05, B06 and B08 just as shown in figure, paste B07 and B08 together, and paste the paper accessories of A11-5 as shown in figure, then add B09 and B10 finishing the keys part, combine the finished parts together and paste B11 and B13 correctly and properly, take the A11-6 cut out, as shown in figure, fold in half, then converts into 90 degrees, and paste onto the proper place. Finally as shown in figure, paste the B39 onto the bottom finishing the piano.

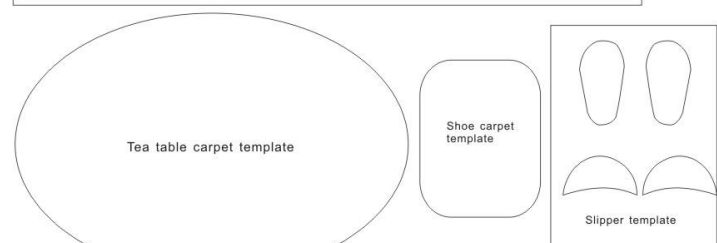
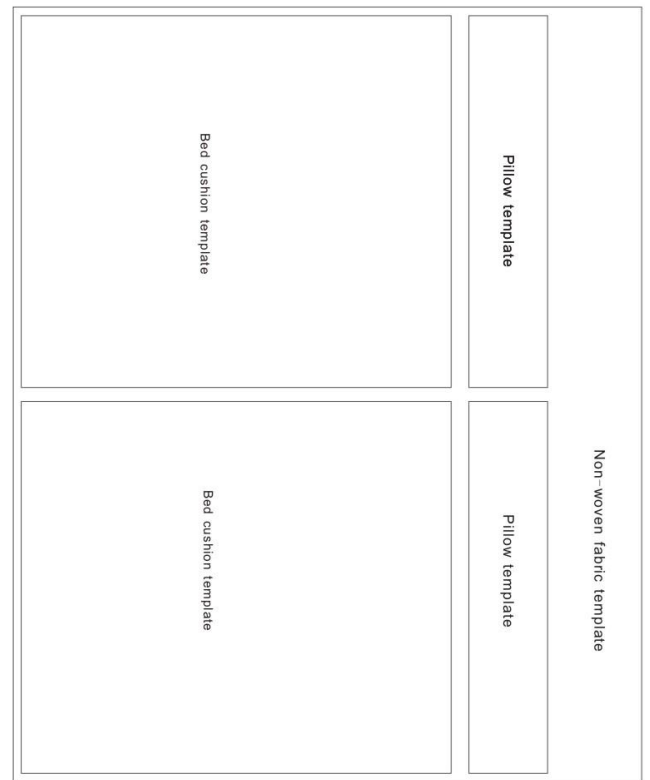
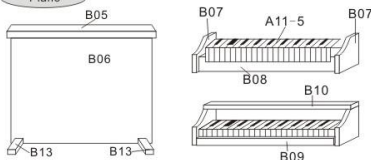

✱ Cut paper parts A11-16, paste it into a gift box according to the following tips.

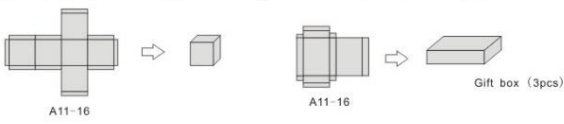

Sound controlled switch

✱ Put the ready-made light on the right position according to the following picture (or color picture), use bulb line along the corner across the reserved space, connect the bulb line and the power source line of the same color, and mount button cell.

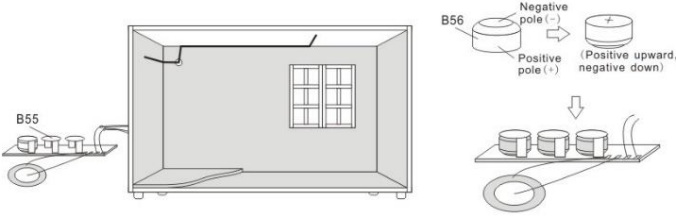

✱ After a hard work, we have finished all of the parts. then, following the pack picture, paste all parts on the right position, and you can paste them according to your style.

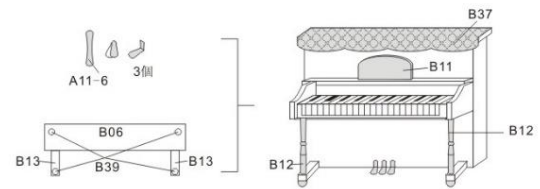

Piano stool

✱ Paste B14-17 as shown in figure finishing the piano stool.

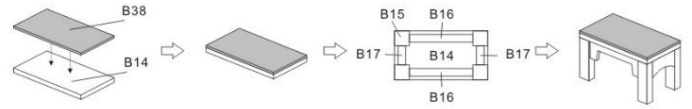

Corner shelf

✱ Paste B18-23 as shown in figure finishing the corner shelf.

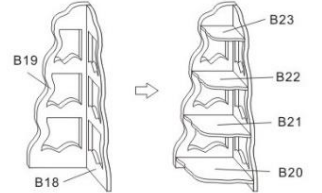

Wall shelf

✱ Cut the C20 into three 1.5cm parts and bend it as shown in figure, then paste B24-26 as shown in figure finishing the wall shelf.

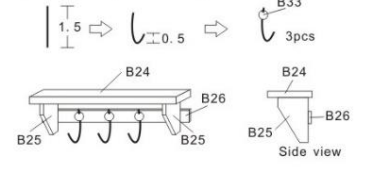

Unit: cm

Parts' Name	Code	Material Name	Color	Thickness	Width	Length	Quantity
Photo frame	B27	Wood	Bury Wood	0.2	1.8	2	1
Wall painting	B28	Wood	White	0.2	3	4	1
Outer frame parts	B29	Wooden bead	White	ø=1.2	1.8	4	4
	B30	Hinge	Golden				2
	B31	Buckle	Golden				1
	B32	Screw	Golden				12
Hanger	B33	Plastic bead	White				3
Fruit basket	B34	Paper rope	Pink			35	1
	B35	Bubble fruit	Orange				2
	B36	Bubble fruit	Green				1
	B37	Lace	White			7.5	1
Decoration in Piano	B38	Bubble paper	Pink	1.8	3.5		1
	B39	Plastic bead	Golden				5
	B40	Rubber hose	transparent			2	1
	B41	Bouquet	Red				1
B42	Lace	White			2.5	1	

Unit: cm

Parts' Name	Code	Material Name	Color	Thickness	Width	Length	Quantity
Curtain	B43	Flower cloth	Pink		10	11	1
Light	B44	Big wire	Golden			33	1
	B45	Small wire	Golden			20	1
	B46	Fine line	Golden			12	1
	B47	Flower shape bead	Golden				6
	B48	Frosted bead	transparent				5
	B49	Metal buckle	Golden				3
	B50	Eyelet button	Golden				2
	B51	Lampshade bead	Golden				1
	B52	Drop beads	transparent				4
B53	paper	White		10	12	1	
Power source	B54	Sand paper					1
	B55	Sound controlled switch					1
	B56	Button switch	Silvery				3
	B57	Bulb string					2
B58	Stick paper			3	15	1	

Photo frame & wall painting

✱ Take the paper accessories of A11-7 cut out, then paste B27 and B28 together as shown in figure finishing the photo frame and wall painting.

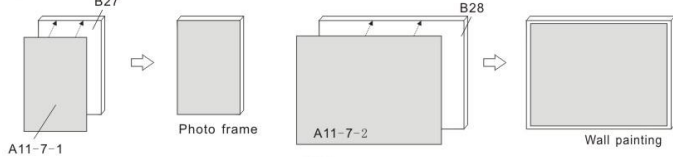

Fruit basket

✱ Cut the redundant iron string of B35 and B36 as shown in figure finishing the fruit; round the B34 into a basket as shown in figure and paste it well, finally the fruit basket is finished.

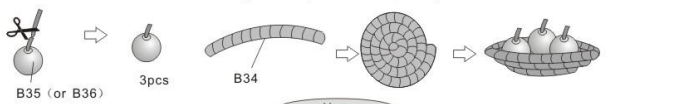

Vase

✱ Cut 1.7 cm from the B40, then paste B40-42 as shown in figure finishing the vase.

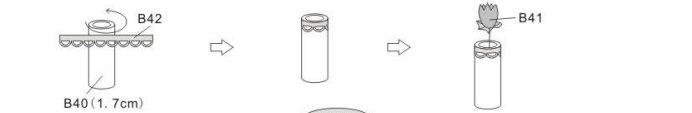

Light

✱ Cut four parts of 6.5 cm from the B44 and bend them as shown in figure, cut four parts of 2.5 cm from B46 and fasten it with B45 as shown in figure finishing the pendant. Cut four parts of 2 cm from the B45, cut four parts of 1.5\*3.5 cm from the B53 and roll B45 up as shown in figure finishing the candle; then combine all the little parts together finishing four parts of pendants, finally wear the pendant parts onto the B51 and fasten it well finishing the pendant.

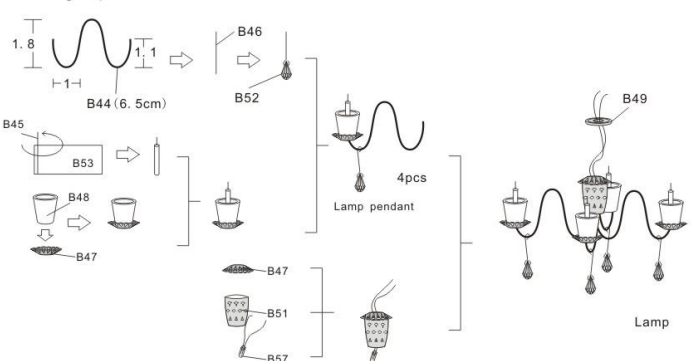

Book basket

✱ Finish the book basket according to the following tips.

Unit: cm

Parts' Name	Code	Material Name	Color	Thickness	Width	Length	Quantity
Book basket	D36	Paper rope	Yellow		50	1	1
Pot culture	D37	Paper	Green		4	4.5	1
	D38	Paper rope	Brown			15	1
	D39	Long plastic bead	Silvery				1
	D40	Wooden bead	bury Wood				1
	D41	Dry flower	Green				Several
	D42	Dry flower	Purple				Several
	D43	Dry flower	Red				Several
	D44	Big wooden bead	bury Wood				1

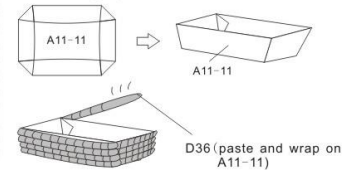

Book

✱ Cut A11-12, and cut 12cm from B53, its width is the same with the height of book pasted, and fold it into organ state, finally finish the book.

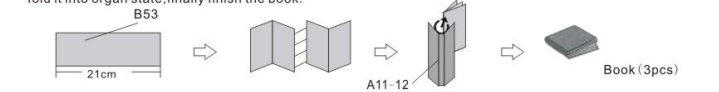

Magazine

✱ Cut A11-13, paste 2 and 3, 4 and 5, 6 and 7, 8 and 9, finally paste 1 and 10, finish a magazine.

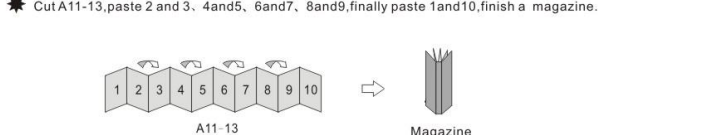

Pot culture

✱ Cut A11-14, paste it into pot culture according to the following tips.

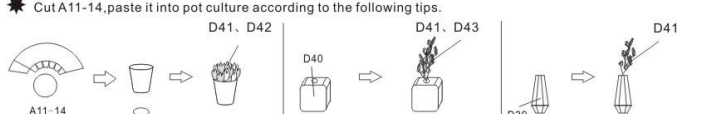

Plant

✱ Put A11-15 paper parts on D37 green paperboard, cut 11 parts along outline, cut two parts of 3.2cm from C20 green fine iron wire, paste 5 or 6 pieces of D37 onto one end of C20. Divide the 15cm D38 brown into two strips, using the strips enclose C20 from top to bottom. (tips: suggest using double-sided adhesive) insert the three branches into D44, adjust the shape of limb and leaves into a plant.

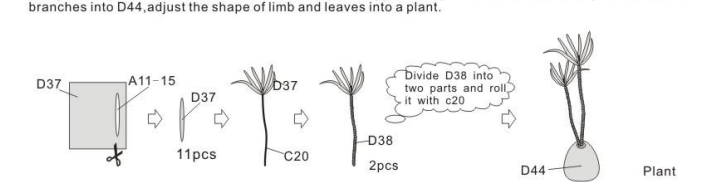

Parts Name	Code	Material Name	Color	Thickness	Width	Length	Quantity
Decorations in Dresser	D14	Paper	Silvery		3	4	1
	D16	Small bead	Golden				8
	D16	Flower shape bead	Golden				2
	D17	Small flower shape bead	Golden				1
	D18	Round bead	White				1
	D19	Round bead	Light blue				1
	D20	Square bead	Light purple				1
	D21	Long bead	Golden				1
	D22	Cylindrical bead	Pink				1
	D23	Small bead	Pink				1
	D24	Long bead	Black				1

Parts Name	Code	Material Name	Color	Thickness	Width	Length	Quantity
Decorations in tea table	D25	Wooden bead	White				4
	D26	short bead	Light blue				2
	D27	Round bead	White				1
	D28	Beads tablets	transparent				1
	D29	Small bead	White				1
	D30	Round Wooden	White	$\phi=0.3$	0.9		1
	D31	Flat plastic beads	White				1
	D32	Wire	Golden				2
	D33	Non-woven	Red		3	5.5	1
	D34	Corrugated paper	White		1	6.5	1
	D35	Small bead	Red				5

Decorations

\* Paste D14 -D24 into the decorations of make-up room.

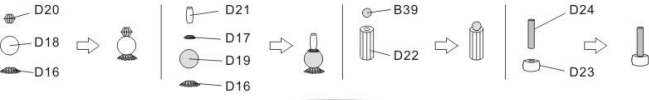

Decorations in tea table

\* Cut 1.5cm from C20 and bend it, cut a part of D30 according to the following tips, then paste D27 and D30 into a teapot.

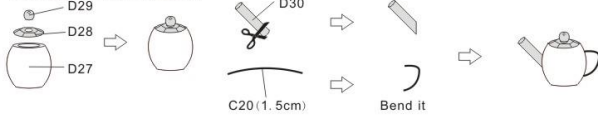

\* Cut 1cm from C32 and bend it, then paste D31 and D47 into a cup.



\* Cut D04 into two pieces of 1.3cm (leave four semi-circles on each side), paste them into teapot carpet according to the following tips.

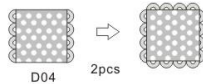

\* Cut a 0.5\*5.1cm from D33 and bend it; cut a 0.2\*4.5cm and paste it into a cake according to the following tips.

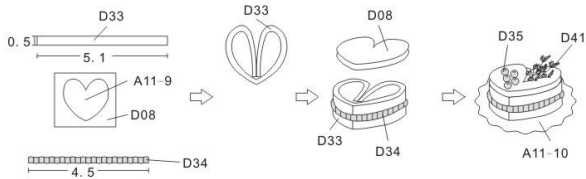

12

\* Cut 5.5 cm from the B44 and bend it as shown in figure, cut four parts 1.3 cm and one part 4cm from the B45 and bend it as shown in figure then paste.

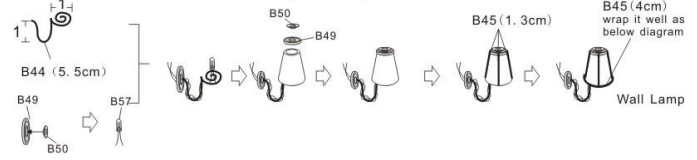

Bag C material with working instructions

Bed

Parts Name	Code	Material Name	Color	Thickness	Width	Length	Quantity
Bed	C01	Wood grain	White	0.3	3.5	7	1
	C02	Wood	burly Wood	0.5	7	9	1
	C03	Wood	White	0.5	0.5	2.5	4
	C04	Wood	White	0.3	0.3	7	3
	C05	Wood grain	White	0.3	1.4	7.8	2
	C06	Round wooden grain	White	0.5	0.5	8	4

\* Paste the material C01 to C06 well as shown in figure.

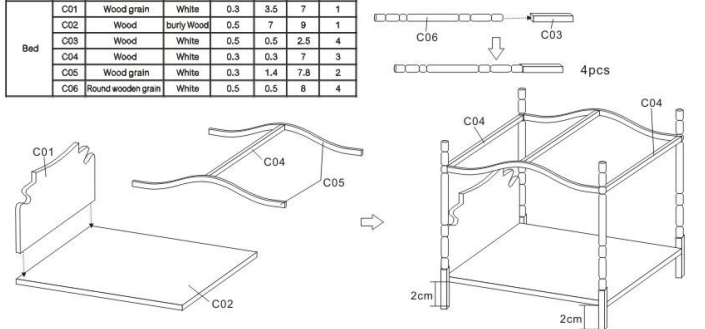

\* Cut the material D06 into a canopy according to the canopy template paper and paste it onto the bed; cut out two pieces respectively of the D08 according to the mattress template and pillow template of non-woven fabrics. (this template is in the final page of the instruction)

\* Cut one mattress and one pillow according to the mattress template and pillow template of the D09 cloth, and wrap the D08 up as shown in figure, finally the mattress and pillow are finished.

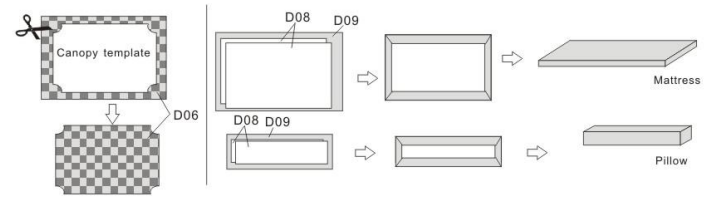

5

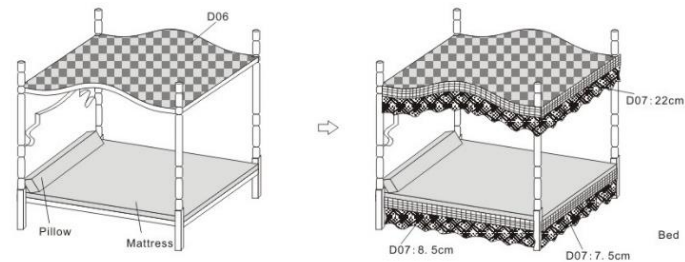

Dresser

Parts Name	Code	Material Name	Color	Thickness	Width	Length	Quantity
Dresser	C07	Wood	White	0.2	2.5	5.2	1
	C08	Wood	White	0.2	2.7	5.6	1
	C09	Wood	White	0.2	1.3	2.4	2
	C10	Wood	White	0.2	2.4	4.6	1
	C11	Wood	White	0.2	1.3	5	1
	C12	Wood	White	0.15	1	1.4	2
	C13	Wood	White	0.15	1	1.7	1
	C14	Wood grain	White	0.3	0.4	3.3	4
	C15	Wood	White	0.2	0.9	5.2	1
	C16	Wood	White	0.2	0.8	1.5	3
	C17	Oval wood grain	White	0.2	2.5	3.4	1
	C18	Wood grain	White	0.2	3	4.6	1
	C19	Wood grain	Pink	0.3	2	2.5	1
	C20	Wire	White			70	1

Parts Name	Code	Material Name	Color	Thickness	Width	Length	Quantity
Sofa	C21	Wood grain	burly Wood	0.2	3.6	5.8	2
	C22	Wood grain	burly Wood	0.2	2.6	4.9	2
	C23	Wood grain	burly Wood	0.2	3	4.9	2
	C24	Wood grain	burly Wood	0.3	3.5	4	2
	C25	Round wooden grain	burly Wood	$\phi=0.5$		1.3	8
	C26	Wood grain	burly Wood	0.2	4.2	8	2
	C27	Wood grain	burly Wood	0.3	3.5	8.2	2
	C28	Wood block	burly Wood	0.5	2.5	2.9	2
	C29	Wood	burly Wood	0.6	0.9	3.3	2
	C30	Wood	White	0.2	3.5	6	1
Tea table	C31	Wood	White	0.2	2.8	5.3	1
	C32	Wood	White	0.2	1.5	5.3	2
	C33	Wood	White	0.2	1.5	2.4	2
	C34	Wood grain	White	0.2	0.8	2.4	2

\* Making a dresser by pasting the material C07-18 together according to the following tips.

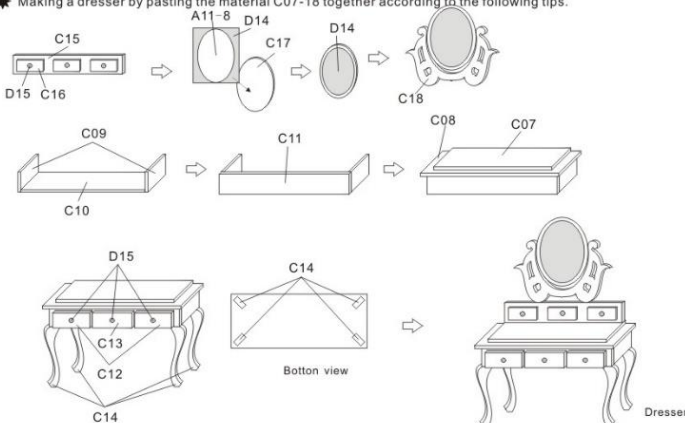

6

Dress

\* Cut 10cm from C20, bend it into a hanger. Cut two segments of 2.6cm from D01, bend them according to the following tips. Cut 3.5cm from both D02 and D03, fold and paste into a dress according to the following tips.

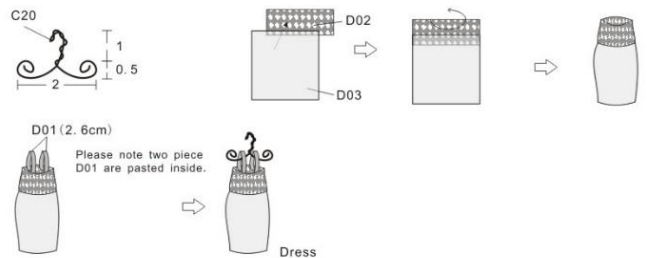

Handbag

\* Cut 4.5cm from D04, then fold and paste D04 and D05 into a handbag according to the following tips.

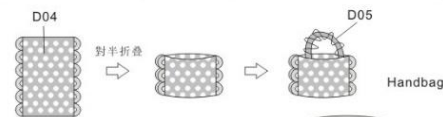

Pillow

\* Cut three pieces of 7cm\*3cm, and 50% discount each of them, then sew along the dotted line. Upside and put suitable cotton in. Sew the openings, finishing three pillows.

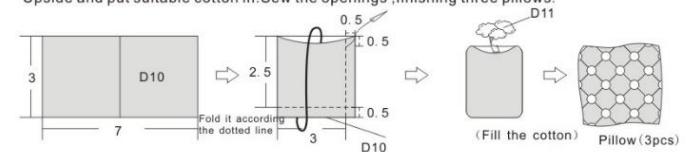

Carpet

\* Cut D12 into carpet according to the tea table's carpet formwork; cut D33 into carpet according to the insole formwork.

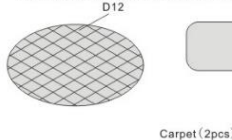

Carpet (2pcs)

Slipper

\* Cut D08 and D13 according to slipper formwork, then paste them into a pair of slippers.

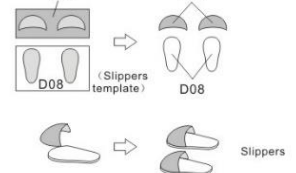

Slippers

11

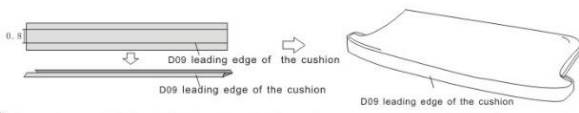

★ Paste the wood C28 and C29 as shown in figure, then paste the clipped D09 left armrest cloth.



★ Finally, cut 9.5 cm from D02 lace, then paste all of the wrapped parts. (reference under figure)

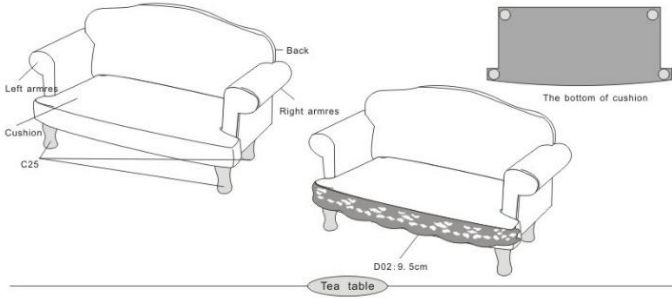

★ Paste C30 and C34 into a tea table.

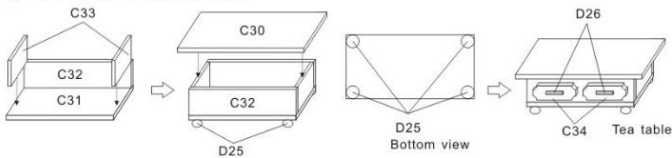

Bag D material with working instruction

Parts Name	Code	Material Name	Color	Thickness	Unit: cm		
					Width	Length	Quantity
Dress	D01	Silk ribbon	Peach red		7	1	
	D02	Lace	White		22	1	
	D03	Big Lace	transparent		4	1	
Hand bag	D04	Dot ribbon	Pink		10	1	
	D05	Lace	Light yellow		4.5	1	
	D06	Plaid fabric	Pink		8.5	10	1
Decoratlon in bed	D07	Lace	Pink		46	1	
	D08	Non-woven	White		18	26	1
	D09	Flower cloth	Light Pink		25	36	1

10

chair

★ Paste the material C19 and C20 well according to the following tips, then the chair is finished.

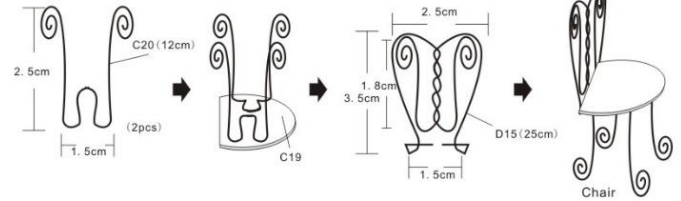

Little sofa

★ Cut out the same shape of cloth from the D08 white non-woven fabric (1).

★ Cut out the same shape of D09 cloth according to the template paper (2).

★ Paste the clipped white non-woven fabric single sofa back upset pad (1)(2)(3) to the chip of C21. (as shown in figure) Then wrap and the clipped D09 back cloth up and paste it on to the C21 chip of the non-woven fabric. (Attention: the one made of non-woven fabric is wrapped on the cover)

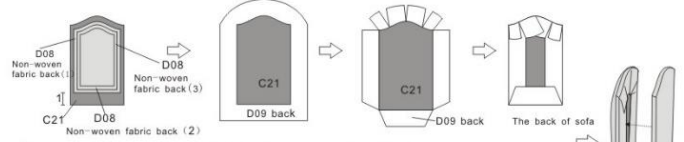

★ Using another clipped D09 back cloth to wrap up the C21 chip.

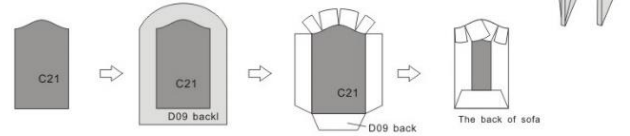

★ Paste the clipped D08 white non-woven fabric cushion mattress (1)(2)(3) onto the C24 chip.

★ Wrap the clipped D09 cushion up and paste it onto the non-woven fabric C24 chip. (as shown in figure) (Attention: The side wrapped with non-woven fabric is wrapped in the cover)

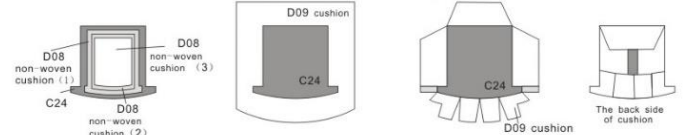

★ Paste on center of another C24 piece of wood with the clipped cushion back, then put cloth of the clipped D09 cushion.

★ Paste and fold a piece of cloth with a width of 0.8 cm according to the dotted line, then paste around the leading edge of the cushion.

7

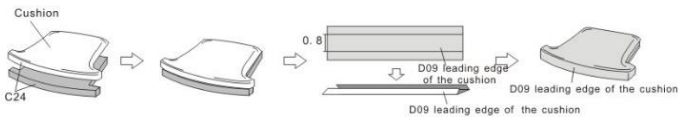

★ Paste the clipped D08 white non-woven fabric armrest (1)(2)(3) onto the C22 chip. (as shown in figure) Then wrap the C22 chip which had pasted by the non-woven fabric with the clipped D09 left armrest (inside). (Attention: The side wrapped with non-woven fabric is wrapped in the cover)

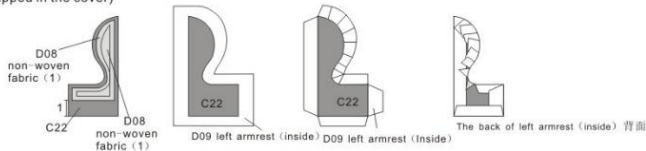

★ Using the non-woven fabric (outside) wrap up C23 chip. (as shown in figure)

★ Frontly align at the back of the two pieces of inside and outside wrapped armrest, then paste them.

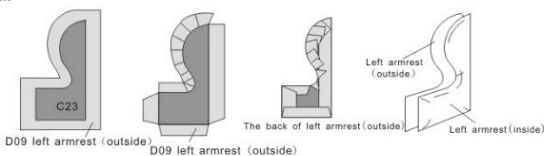

Attention: Is the same with the right armrest, but distinguish right and left, inside and outside, then paste the material. Finally, combine all of the wrapped parts. (reference under figure)

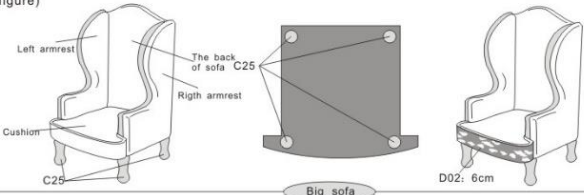

★ Paste the clipped D08 white non-woven fabric back mattress (1)(2) onto the C26 chip. (as shown in figure) Then wrap the C26 chip which had pasted by the non-woven fabric with the clipped D09 back cloth. (attention: The side wrapped with non-woven fabric is wrapped in the cover)



8

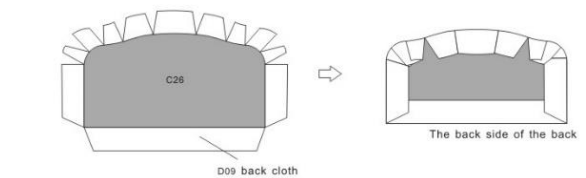

★ Using another clipped D09 back cloth wrap up C26 chip.

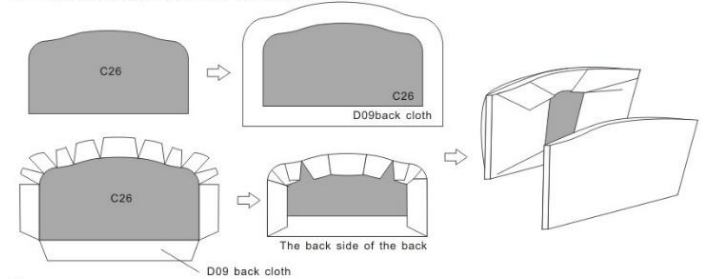

★ Paste the clipped D08 white non-woven fabric cushion mattress (1)(2)(3) onto the C27 chip. Using the clipped D09 cushion cloth wrap up C27 chip which had pasted by the non-woven fabric. (as shown in figure) (attention: The side wrapped with non-woven fabric is wrapped in the cover)

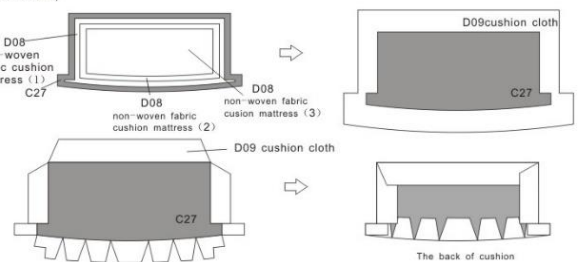

★ Paste another B27 wood onto the back's middle of the clipped cushion, then put cloth of the clipped D09 cushion, paste and fold a piece of cloth with a width of 0.8 cm according to the dotted line, then paste around the leading edge of the cushion.



9