



12 IN. DEEP PREMIER CLOSET ORGANIZER ASSEMBLY INSTRUCTIONS

16 IN. DEEP DELUXE CLOSET ORGANIZER ASSEMBLY INSTRUCTIONS

Sistema De Armario - Instrucciones de ensamblaje

Systeme De Placard - Directives d'assemblage

IMPORTANT: DO NOT RETURN TO STORE!

**For missing or damaged parts, technical or assembly questions,
please call John Louis Customer Service at 1-800-480-6985**

IMPORTANTE: ¡NO LO DEVUELVA A LA TIENDA!

**Llame al servicio al cliente local de John Louis al 1-800-480-6985
para aclarar sus dudas sobre pérdidas, daños, asuntos técnicos y ensamblaje.**

IMPORTANT: NE PAS RENVOYER OU RAPPORTER AU MAGASIN!

**Si vous avez une question concernant l'assemblage, des pièces manquantes ou endommagées ou
un problème technique, appelez le Service à la clientèle de John Louis au 1-800-480-6985.**

PARTS LIST

Lista De Piezas

Liste Des Pièces

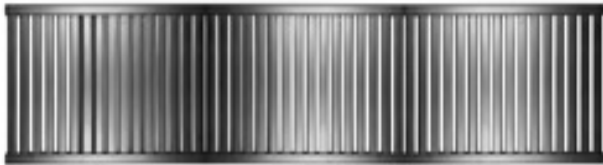

Quantity: 1 72 in. Shelf

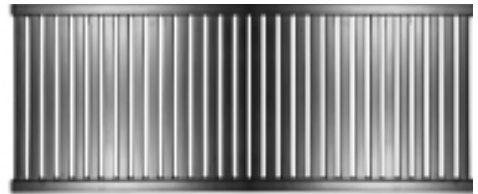

Quantity: 2 48 in. Shelf



Quantity: 2 24 in. Adjustable Shelf

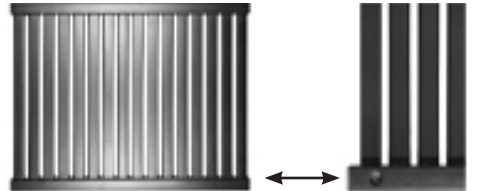

Quantity: 1 24 in. Tower Bottom Cam Shelf



Quantity: 2 72 in. Tower Side

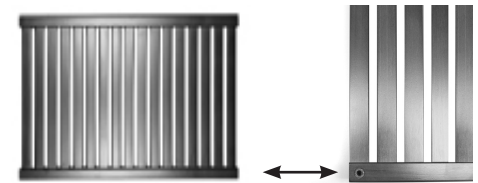

Quantity: 1 26.25 in. Tower Top Shelf



Quantity: 1 72 in. Garment Bar



Quantity: 6 Angle Bracket



Quantity: 2 48 in. Garment Bar



Quantity: 6
J-Hook



Quantity: 6
Tower Bracket



Quantity: 7
Shelf End



Quantity: 14
Shelf mounting L- Clip



Quantity: 6
Bar End



Quantity: 6
Angle Bracket Mushroom
Cap



Quantity: 6 #8 3 in.



Quantity: 64 #8 1 1/2 in.



Quantity: 56 Wall Anchor



Quantity: 12
#8 1 in. (J-Hook)



Quantity: 14
#8 3/4 in.



Quantity: 4
#8 1/2 in.



Quantity: 24
#4 3/4 in.



Quantity: 6 #6 1 1/4 Self Tapping Screw



Quantity: 4
Cam Bolt



Quantity: 4
Tower Mushroom Cap



Quantity: 16
Adjustable Shelf Pin



Quantity: 1
Touch Up Stain Pen



Quantity: 4
Barrel Bolt



Quantity: 4
Barrel Nut



Quantity: 5
Cam Lock Nut



Quantity: 1
Allen wrench

Contact Contact0 Contacter

For questions concerning missing or damaged parts, technical specs and / or assembly help, please contact John Louis Home Customer Service at:

Si tiene preguntas sobre partes faltantes o dañadas, especificaciones técnicas o asistencia para el armado, comuníquese con el Servicio al Cliente de John Louis Home:

Pour toute question relative à des pièces manquantes ou endommagées, toute spécification technique et/ou aide au montage, contactez le service après-vente de John Louis Home au :



1.800.480.6985 service@johnlouishome.com www.johnlouishome.com

John Louis Home 4310 Rider Trail North Earth City, Missouri 63045 USA

© 2016 John Louis Inc., All Rights Reserved.

IMPORTANT - Read Before Assembly

12 in. deep Premier Organizer and 16 in. deep Deluxe Organizer use the same assembly instruction process **EXCEPT DURING THE J-HOOK PLACEMENT ON THE ANGLE BRACKET**.

Assembly instructions are written for 8 ft. configuration A. All assembly processes are the same for each configuration **EXCEPT** for the order or locations of the assembly process. Use selected configuration for shelf locations.

Shelf lengths and Garment bars may need to be cut depending upon configuration desired.

All cut shelf lengths are used in closet configurations supplied. Depending upon your closet dimensions, some cut lengths may not be usable.

EXAMPLE: If you choose an 8 ft. closet configuration and the width of your closet is 8 ft. 4 in., the cut shelf length will be short 4 in. for use. It is recommended that if your closet is over the selected dimension (8 ft.), then choose a configuration from the next dimension higher (10 ft.).

EXAMPLE: If you choose an 8 ft. closet configuration and the width of your closet is 7 ft. 6 in., some shelf lengths may need to be cut 6 in. shorter in length to fit closet dimensions.

VERIFY SHELF MEASUREMENTS MEASURE - MARK - MEASURE AGAIN

Chosen configuration may not require use of all hardware or components supplied.

It is recommended to secure hardware into wall studs for overall strength and stability of closet system.

If choosing a custom designed configuration, modifications to the instructions provided will be necessary.

All configurations provided may be reversed.

STEP 1 - Determining Your Dimensions

1. Locate your desired configuration (**Instructions are written for 8 ft. configuration A**).
2. Double hang is created with 2 - 4 ft. shelf length.
3. Long hang is created by cutting a 6 ft. shelf to 21.75 in. wide. (**If your closet is greater or less than 8 ft. wide you will cut your shelf greater or less that distance. EXAMPLE: Closet is 8 ft. 5 in. - cut shelf 26.75 in. EXAMPLE: Closet is 7 ft. 10 in. - cut shelf 19.75 in.**)

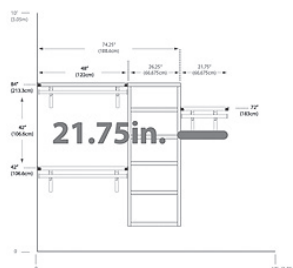
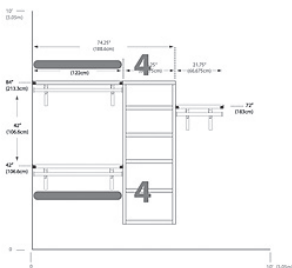

STEP 2 - Marking Measurements On Wall

1. Locate the 3 main shelf height locations for your configuration.
2. Measure up from the floor & mark the 84 in. location.
3. Measure up from the floor & mark the 42 in. location.
4. Measure up from the floor & mark the 72 in. location.

84 in. - top shelf

42 in. - lower hang shelf

72 in. - long hang shelf

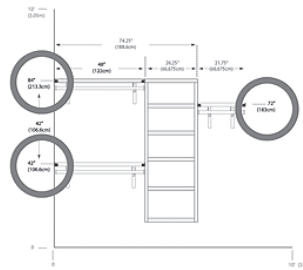

5. Draw a 6 ft. long level line out from wall end at 84 in. location.
6. Draw a 4 ft. long level line out from wall end at 42 in. location.
7. Draw a 22 in. long level line out from wall end at 72 in. location.
8. Locate stud locations at level lines.

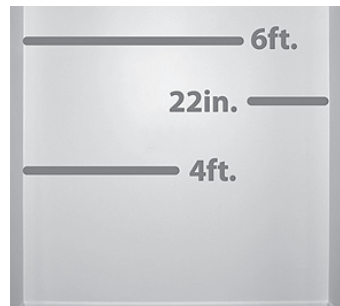

STEP 3 - Tower Assembly

1. Place tower sides down with grooves facing up.
2. Insert cam bolts at tower bottom hole locations.
3. Insert tower sides into tower bottom.
4. Insert cam nuts into tower bottom shelf with arrow facing bolt hole.
5. Secure by turning cam nuts clockwise to tighten.
6. Repeat for opposite tower side.

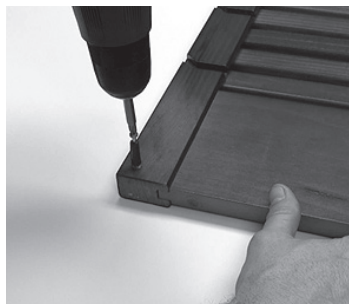

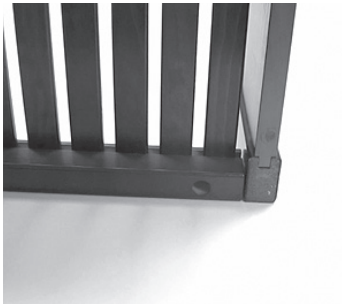
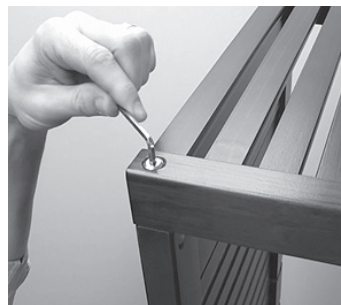
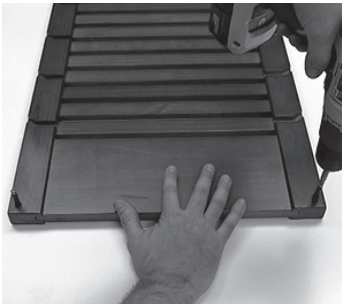

11. Place tower face down (nameplate typically designates tower front)
12. Place top tower bracket between 1st & 2nd groove.
13. Place middle tower bracket between 8th & 9th groove.
14. Place bottom tower bracket between last groove & tower bottom.
15. Repeat for opposite side.
16. Secure brackets to tower using #8 3/4 in. screws.



7. Place tower top into notches at top of tower.
8. Insert barrel nuts into tower sides with slot in a vertical position.
9. Insert barrel bolts into tower top
10. Flush Tower top with tower side & tighten with allen wrench provided (nut position may need adjustment).

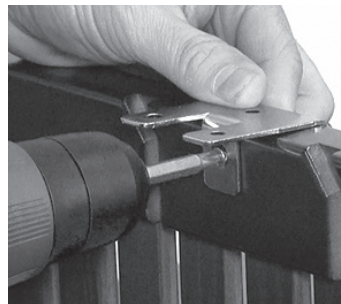

STEP 4 - Installing Top Shelf & Tower

It is recommended to install hardware into wall studs. Typically 16 in. on center. Use 50 lb. wall anchors provided if no stud is present.

On the top level line space shelf mounting L-clip hardware equidistant in the following manner:

- 3 L-clip hardware within the 48 in. shelf location
- 2 L-clip hardware within the tower top location

NOTE: 1 L-CLIP HARDWARE MUST BE INSTALLED INTO A WALL STUD AT TOWER TOP LOCATION

1. Center the top screw hole of the shelf mounting L-clip hardware with the level line & mark all hole locations.
2. Secure L-clip to wall using #8 1 1/2 in. screws at hole locations (Use wall anchors provided if no stud is present).
3. Repeat for remaining L-clip locations.

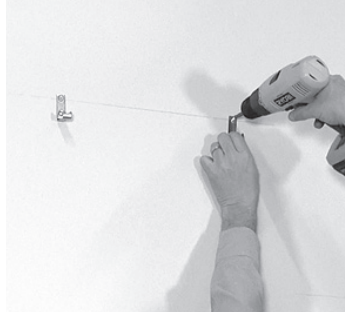
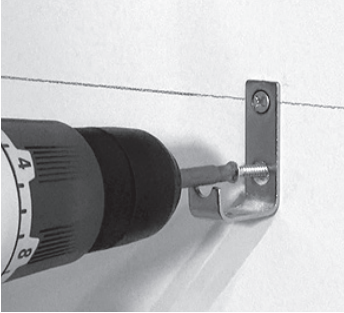
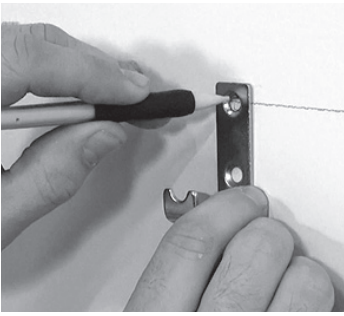

4. Place tower onto wall
5. Place shelf onto L-clips.
6. Place a shelf end onto the wall end of the shelf.
7. Level shelf front to back & mark shelf end hardware location on wall.

Make sure level is positioned on front & back rail. NOT SLATS. If level is placed on slats the shelf will not be level.



8. Place a shelf end onto the tower of the shelf.
9. Flush tower with top shelf.

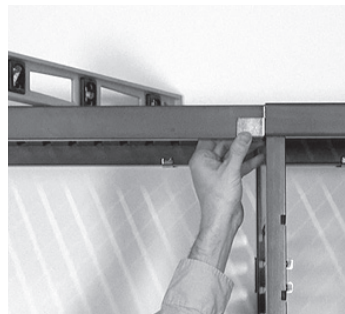
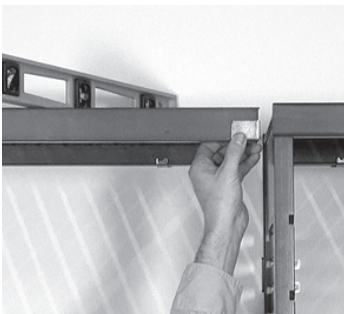

10. Level shelf front to back & mark shelf end hardware location on tower.
11. Plumb level tower side.
12. Mark tower bracket hole locations on wall.
13. Remove shelf and tower.



14. Align shelf end hardware with the mark on the wall & mark screw hole locations.
15. Secure shelf end to wall using #8 1 1/2 in. screws at hole locations (Use wall anchors provided if no stud is present).
16. Align shelf end hardware with the mark on the tower & mark screw hole locations.
17. Secure shelf end to tower top using #8 1/2 in. screws at hole locations.

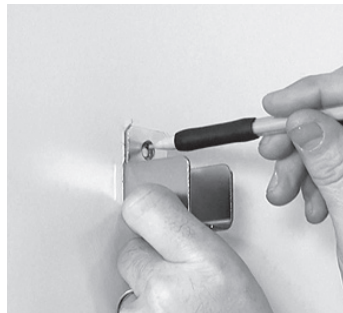

18. Install wall anchors at tower bracket locations if no stud is present.
19. Place tower onto wall and align with hole locations.
20. Place shelf onto wall hardware.
21. Secure shelf to hardware using #4 3/4 in. screws at all hardware locations.
22. Secure tower to wall using #8 1 1/2 in. screws at all bracket locations.

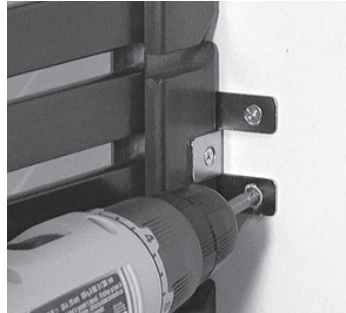
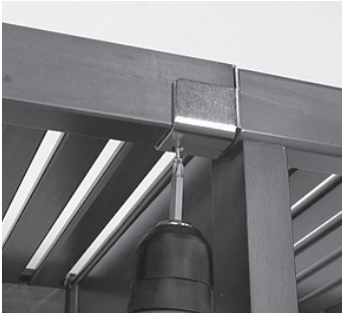
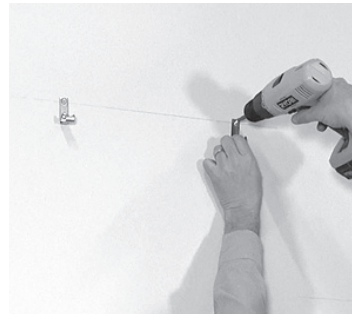
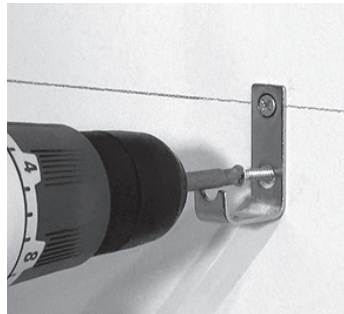

7. Double check required shelf measurement at shelf height location.
8. Measure, mark & cut required shelf dimensions .
9. Place shelf end hardware onto shelf end at side wall location.
10. Place shelf onto shelf mounting hardware.



STEP 5 - Installing Secondary Shelves

1. Lower hang shelf is created using a 4 ft. shelf.
2. Long hang is created by cutting a 6 ft. shelf to 21.75 in. wide. (If your closet is greater or less than 8 ft. wide you will cut your shelf greater or less that distance. EXAMPLE: Closet is 8 ft. 5 in. - cut shelf 26.75 in. EXAMPLE: Closet is 7 ft. 10 in. - cut shelf 19.75 in.)

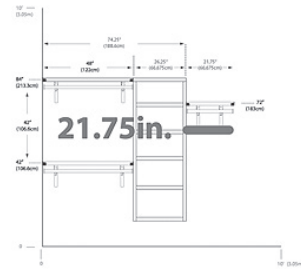
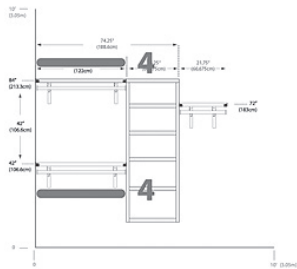

3. Mark L clip hardware locations for secondary shelves.
 - It is recommended to install hardware into wall studs. Typically 16 in. on center. Use 50 lb. wall anchors provided if no stud is present.
 - Space L-clip hardware equidistant in the following manner:
 - 4-5 L-clip hardware per 6 ft. shelf span
 - 3-4 L-clip hardware per 4 ft. shelf span
 - 2 L-clip hardware per 2 ft. shelf span
4. Center the top screw hole of the shelf mounting L-clip hardware with the level line & mark all hole locations.
5. Secure L-clip to wall using #8 1 1/2 in. screws at hole locations (Use wall anchors provided if no stud is present).
6. Repeat for all L-clips at shelf height location.



11. Level shelf.
12. Mark a level line on the side wall at the bottom and side of hardware.
13. Place shelf end hardware onto shelf end at tower location.
14. Level shelf.
15. Mark a level line on the tower side at the bottom and side of hardware.

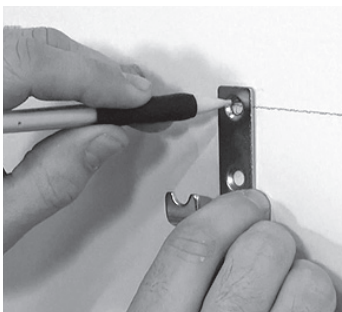

16. Remove shelf & place shelf end hardware at lines and mark screw hole locations.
17. Secure shelf end hardware to wall using #8 1 1/2 in. screws. Use supplied wall anchor at marked location if no stud is present.
18. Secure shelf end hardware to tower side using #8 3/4 in. screws.

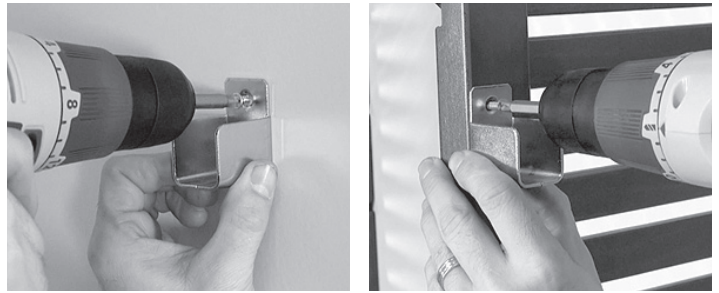
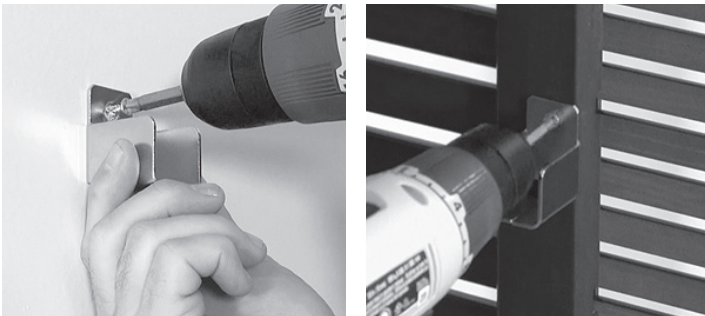
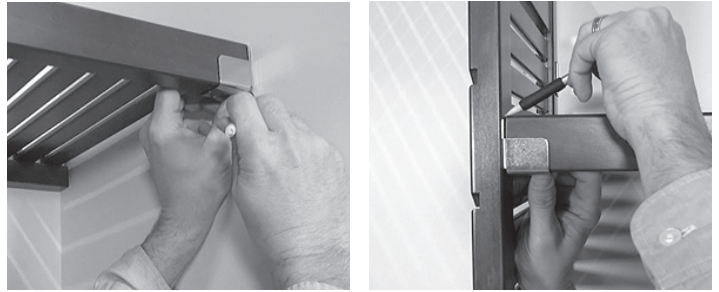
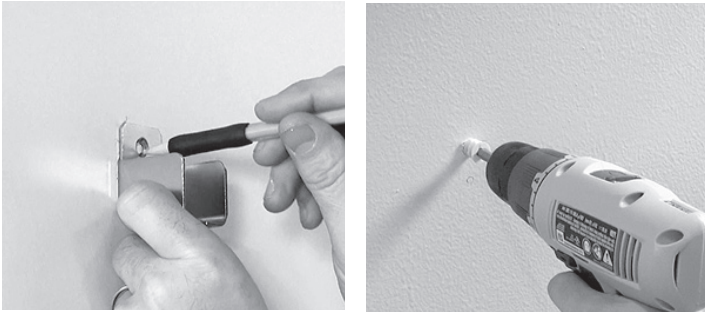

19. Place shelf into shelf end hardware & onto L-clip hardware.
20. Secure shelf to hardware using #4 3/4 in. screws at all hardware locations.

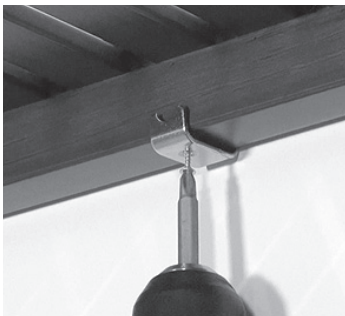
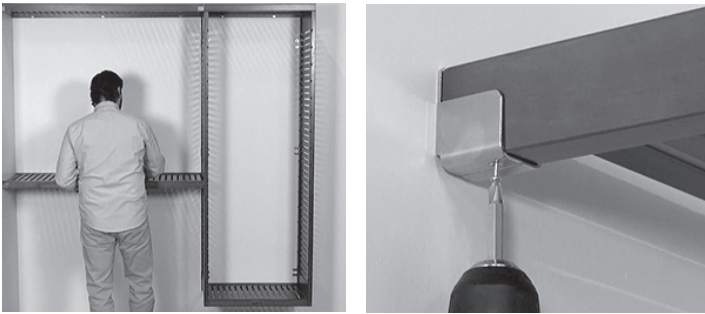

21. Repeat steps for additional secondary shelf.



STEP 6 - Installing Angle Brackets

16 in. Angle Bracket used with 16 in. deep Deluxe Organizer

1. Measure 3 in. back from front of angle bracket & mark location.
2. Place J-hook snug with underside of bracket & align the front edge of the J-hook with the mark.
3. Secure using #8 1 in. screws.
4. Repeat for each angle bracket & J-hook.

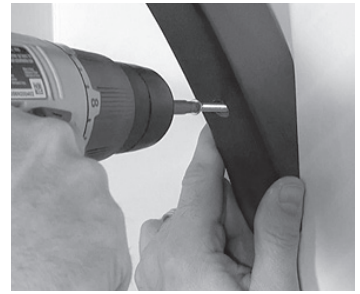
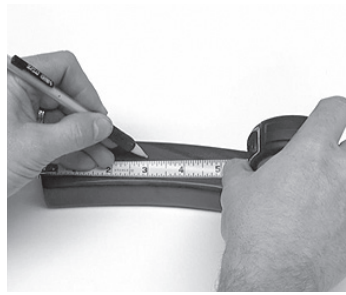

12 in. Angle Bracket used with 12 in. deep Premier Organizer

On the 12 in. angle bracket install it is recommended to pre-pilot screw hole locations with a 1/8 in. drill bit prior to securing the J-hook to the angle bracket.

1. Place J-hook snug with underside of bracket & flush the front edge of the J-hook with the front of the angle bracket.
2. Secure using #8 1 in. screws.
3. Repeat for each angle bracket & J-hook.



10. Repeat for 2nd angle bracket.
11. Repeat for all shelf locations.

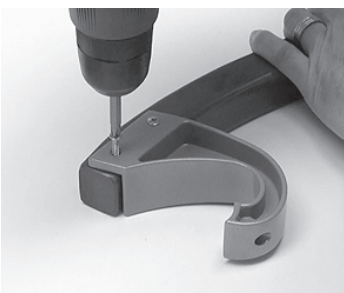

4. Insert #8 3 in. screw into angle bracket.
5. Position angle bracket 6 in. or 4 slats in from shelf end (bracket may be positioned in your desired location).
6. Ensure bracket is square with shelf underside & back wall.
7. If no stud is present, mark hole location by driving screw into drywall.
8. Install anchor if no stud is present.
9. Secure angle bracket using #8 3 in. screw.



STEP 7 - Installing Garment Bars

1. Locate the bar dimensions in your configuration guide
2. The double hang garment bars are created by using 2 - 4ft. bars.
3. The long hang garment bar is created by cutting a bar to 21 in. wide. (If your closet is greater or less than 8 ft. wide you will cut your shelf greater or less that distance. EXAMPLE: Closet is 8 ft. 5 in. - cut shelf 26 in. EXAMPLE: Closet is 7 ft. 10 in. - cut shelf 19 in.)

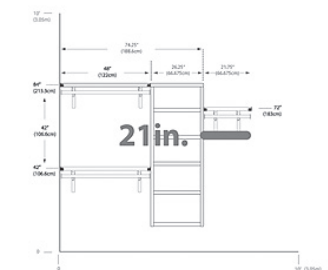
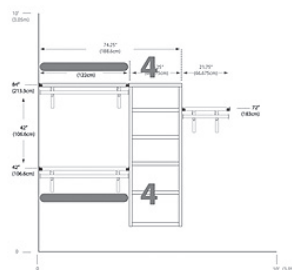

4. Double check bar measurements.
5. Measure required dimension, mark & cut bar (if necessary).
6. Repeat for all bars.

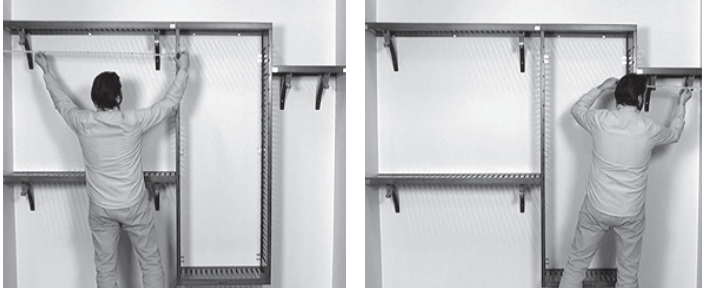

7. Insert bar end into end of garment bar.
8. Turn clockwise to tighten & repeat for each bar end.

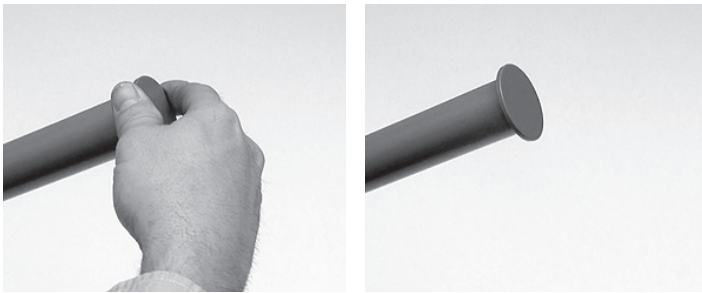
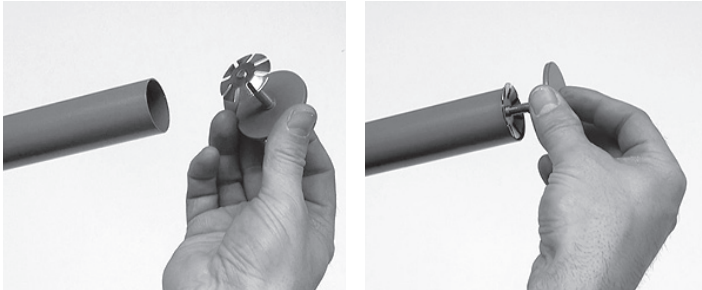

9. Place garment bar onto J-hooks.
10. Secure garment bar to J-Hooks using #6 1 1/4 in. self tapping screws.
11. Repeat for all garment bar locations.

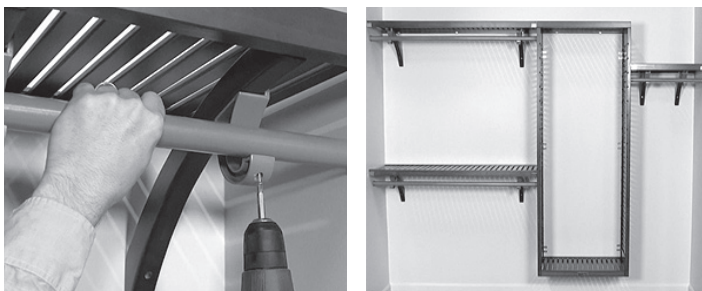
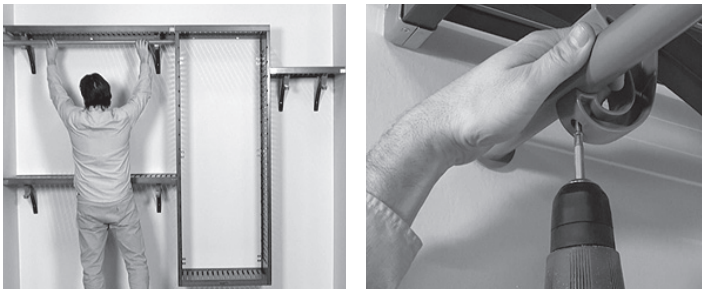

STEP 8 - Installing Adjustable Shelves

1. Select a 24 in. adjustable shelf
2. Insert shelf pin into shelf at hole location.
3. Repeat at each hole location.



4. Place the shelf into the tower by inserting the pins into the tower grooves.
5. Create a shoe shelf by inserting the shelf upside down with the back one groove higher than the front.



Creating Adjustable Shelves

Put your excess cuts back into your closet. Any material greater than 24 in. wide can be used as an additional shelf.

Cut excess lengths to 24 in. wide to use as tower shelves & place where ever you choose.

In an 8 ft. closet configuration your 4 ft. of excess shelving can create 2 additional adjustable shelves.



1. Measure required dimension, mark & cut shelf (if necessary).
2. Place shelf end bracket onto shelf.

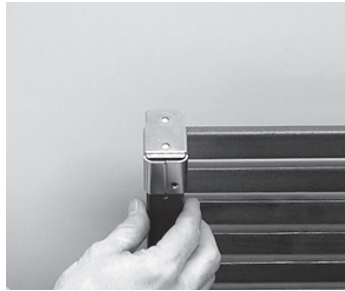
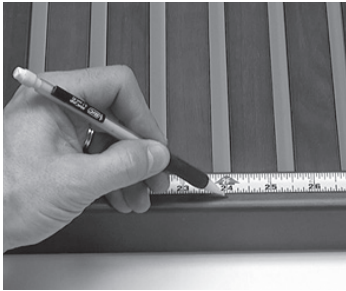

3. Using the lower hole location on the bracket, drill a pilot hole using a 1/8 in. drill bit.
4. Remove the shelf end bracket.

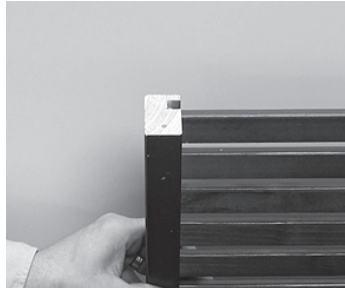
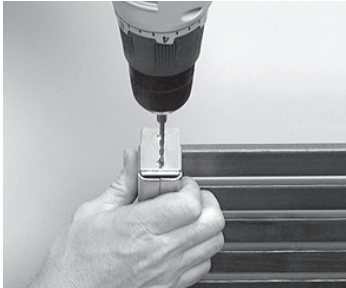

5. Re-drill hole 1 - 1 1/4 in. deep using a 1/4 in. drill bit.
6. Repeat steps for each shelf end.
7. Insert shelf pin into holes at each end.

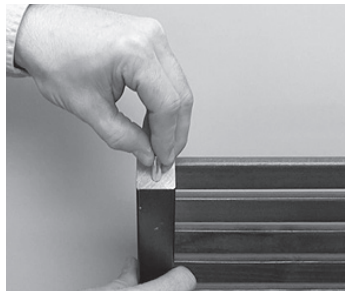
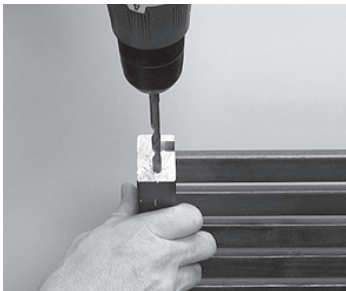

STEP 9 - Final Touches

1. Insert mushroom caps into all angle brackets.
2. Insert mushroom caps into barrel nut holes on tower sides.
3. Touch up scratches & cut ends with stain pen provided.



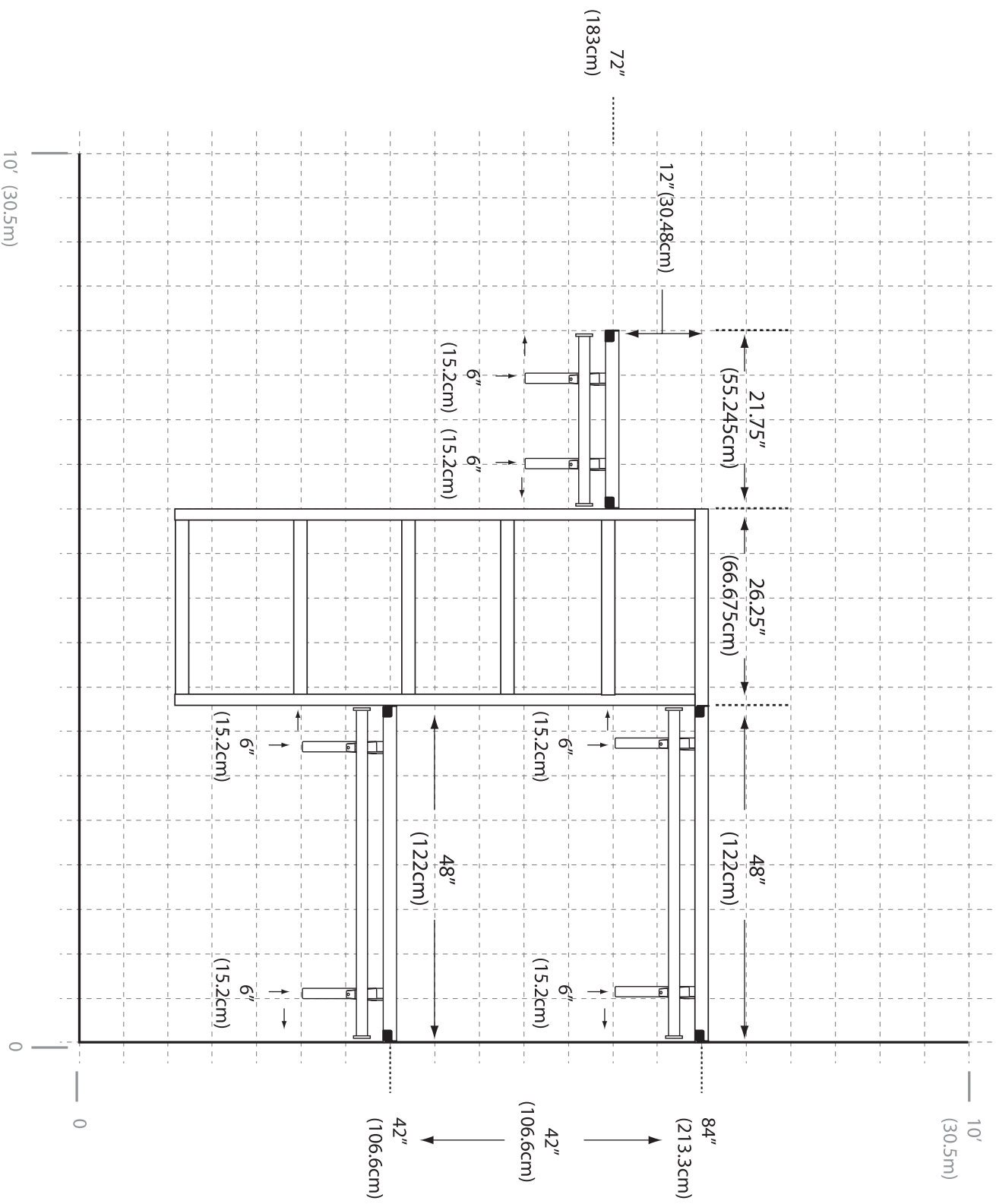

8' CONFIGURATION A **A CONFIGURACIÓN DE 2.5 M** **A CONFIGURATION DE 2.44 M**
 ■ = 6" (15.2cm)

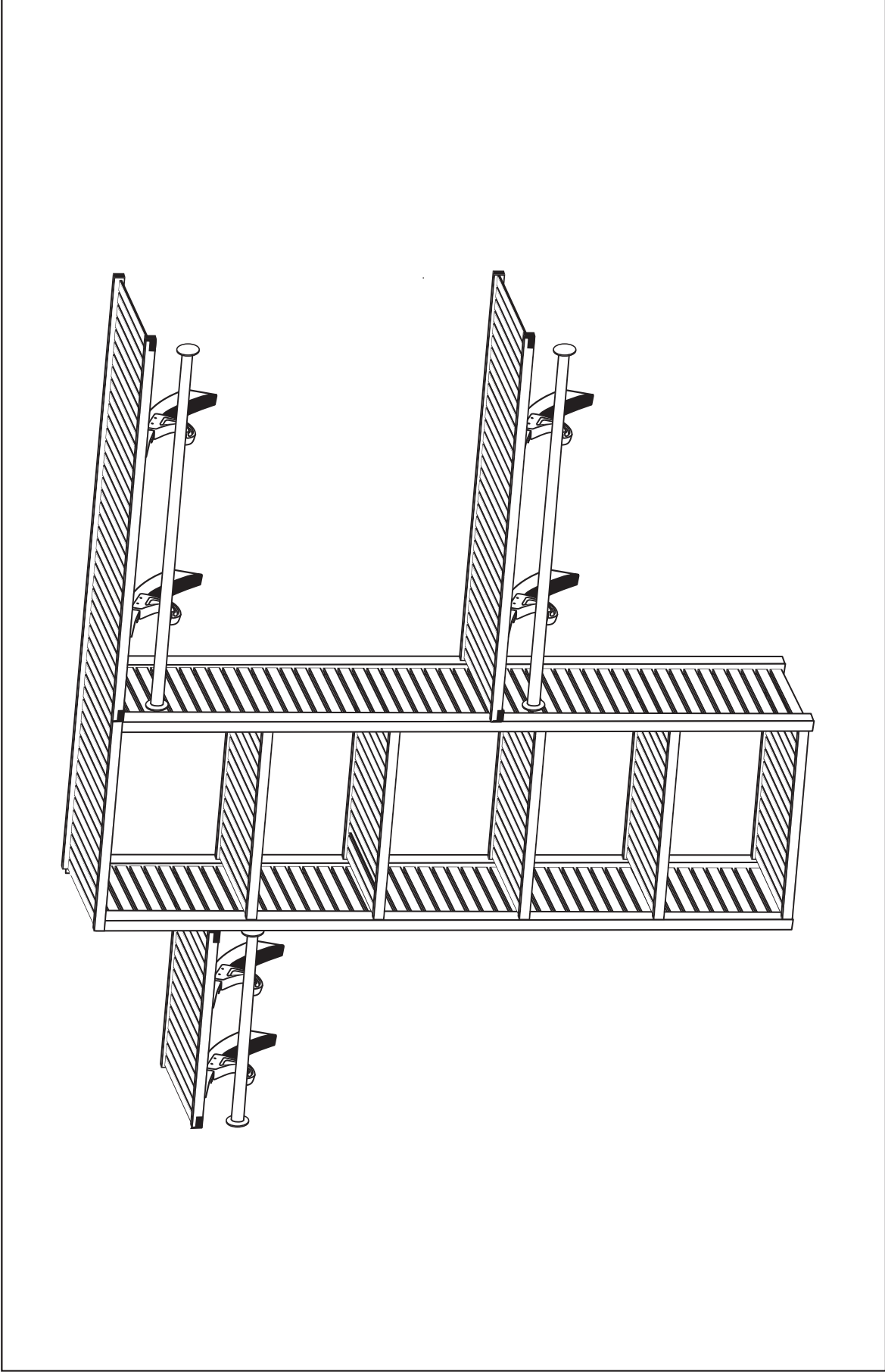

8' CONFIGURATION A A CONFIGURACIÓN DE 2.5 M A CONFIGURATION DE 2.44 M

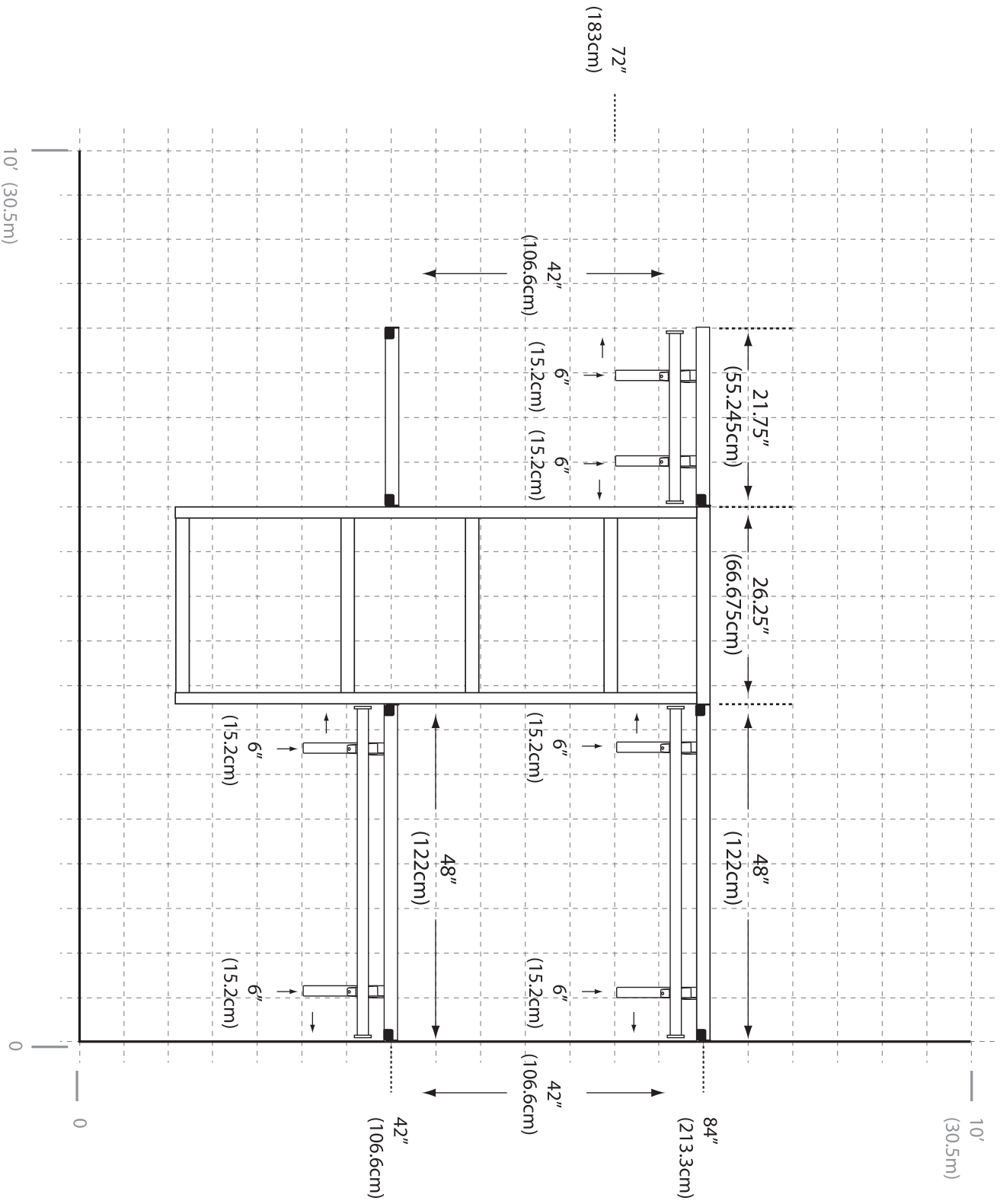

8' CONFIGURATION B B CONFIGURACION DE 2.5 M B CONFIGURATION DE 2.44 M

■ = 6" (15.2cm)

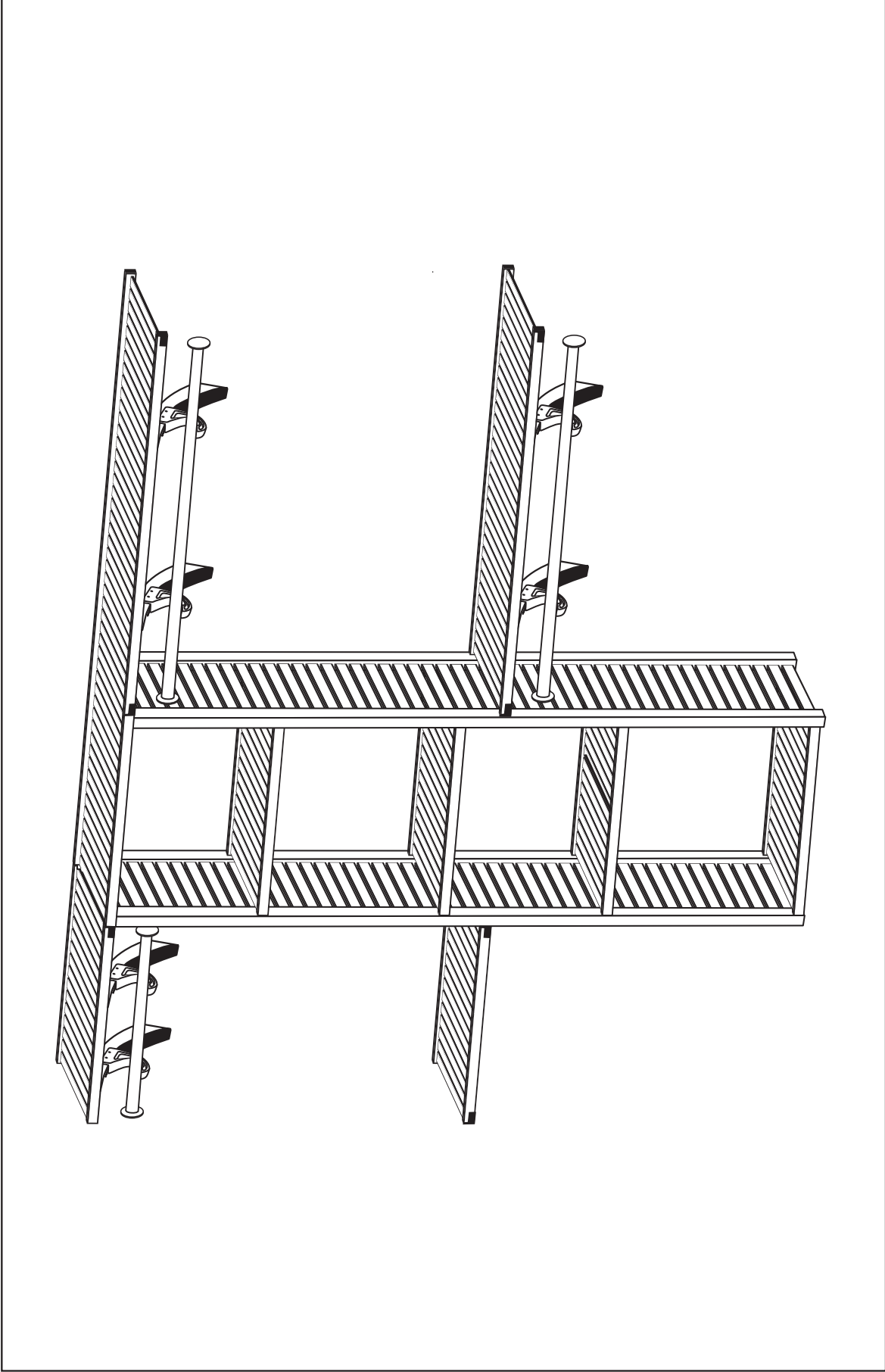

8' CONFIGURATION B B CONFIGURACIÓN DE 2.5 M B CONFIGURATION DE 2.44 M

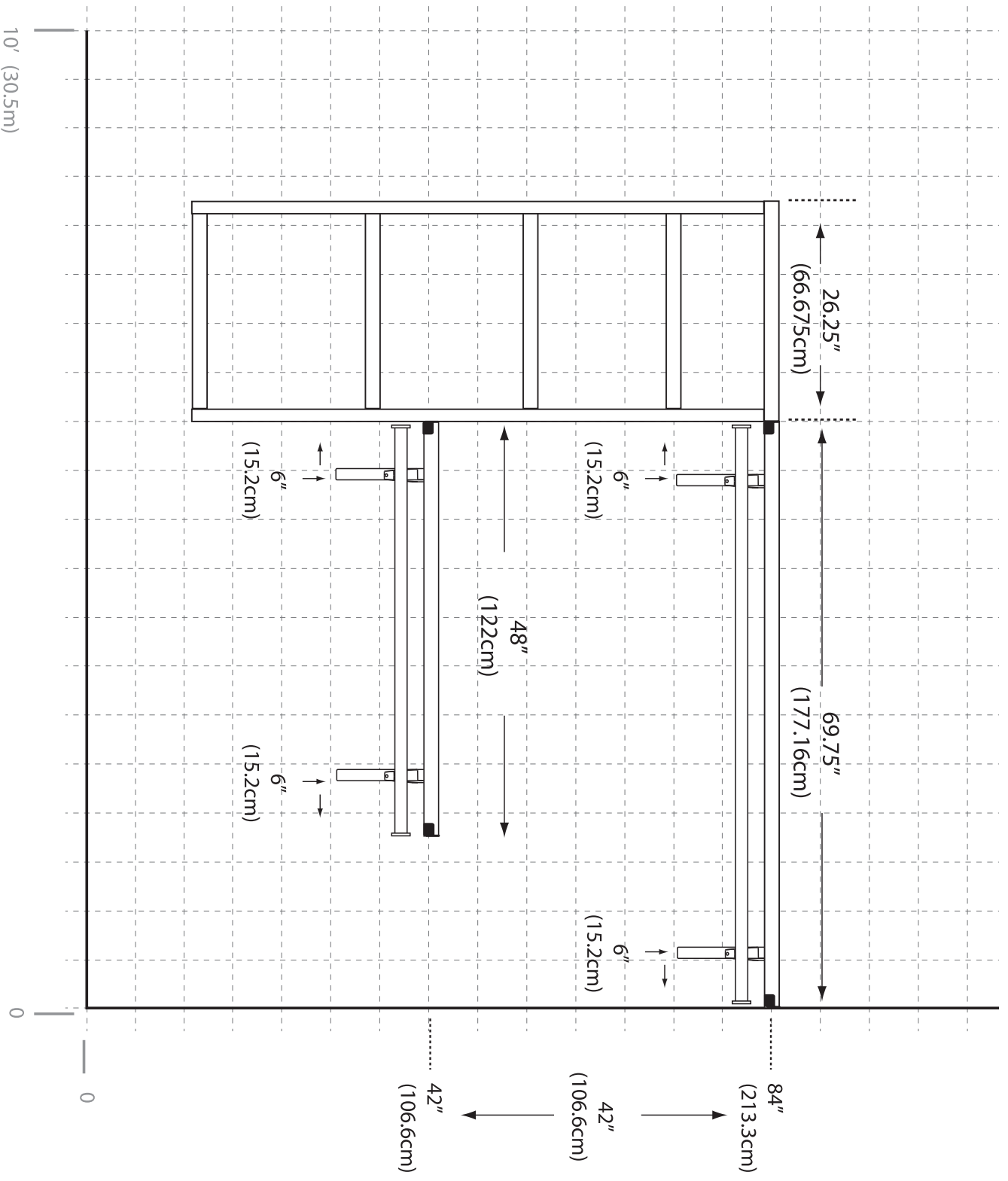

8' CONFIGURATION C C CONFIGURACIÓN DE 2.5 M C CONFIGURATION DE 2.44 M

6" = 6" (15.2cm)

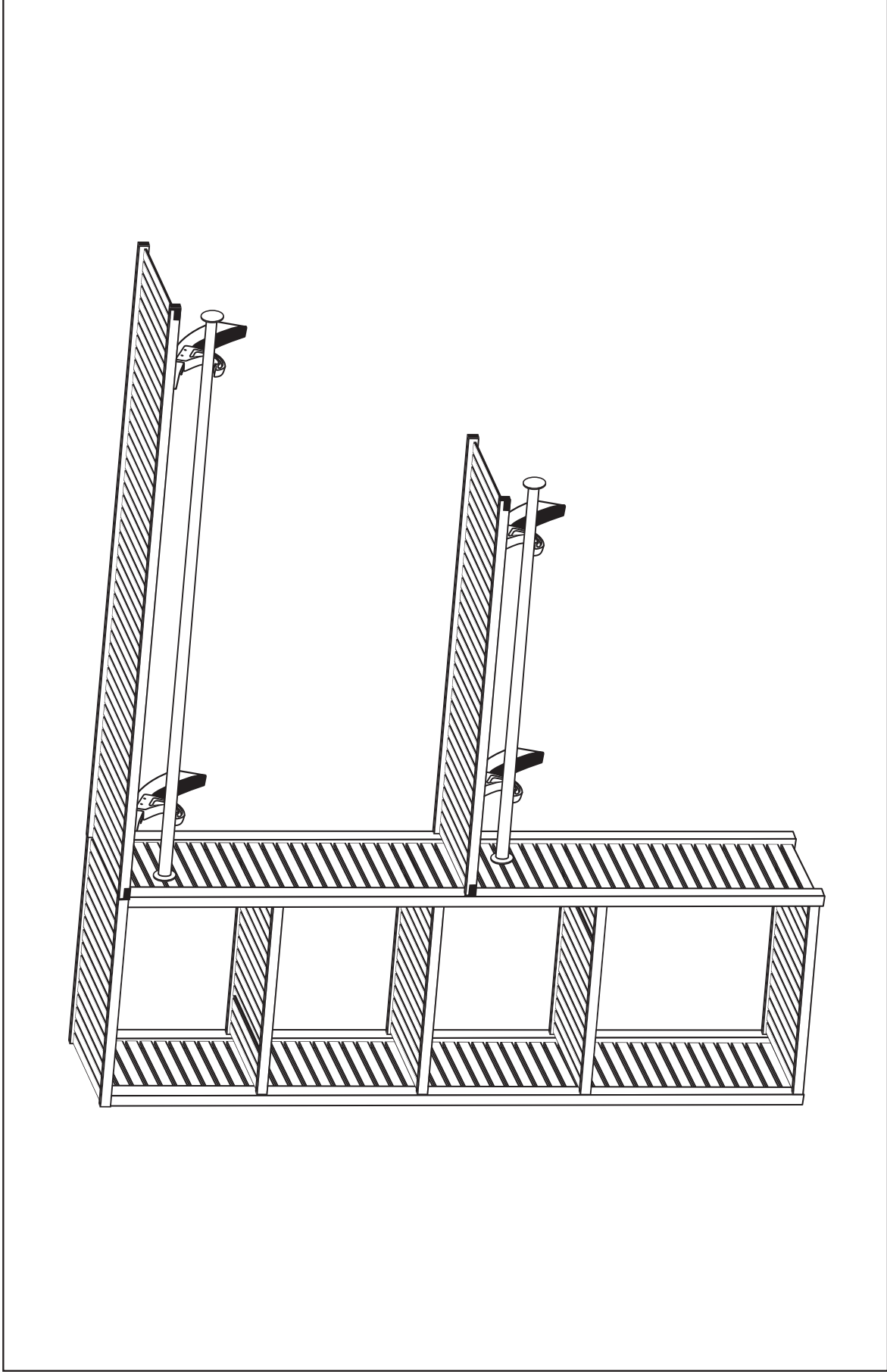

8' CONFIGURATION C C CONFIGURACIÓN DE 2.5 M C CONFIGURATION DE 2.44 M

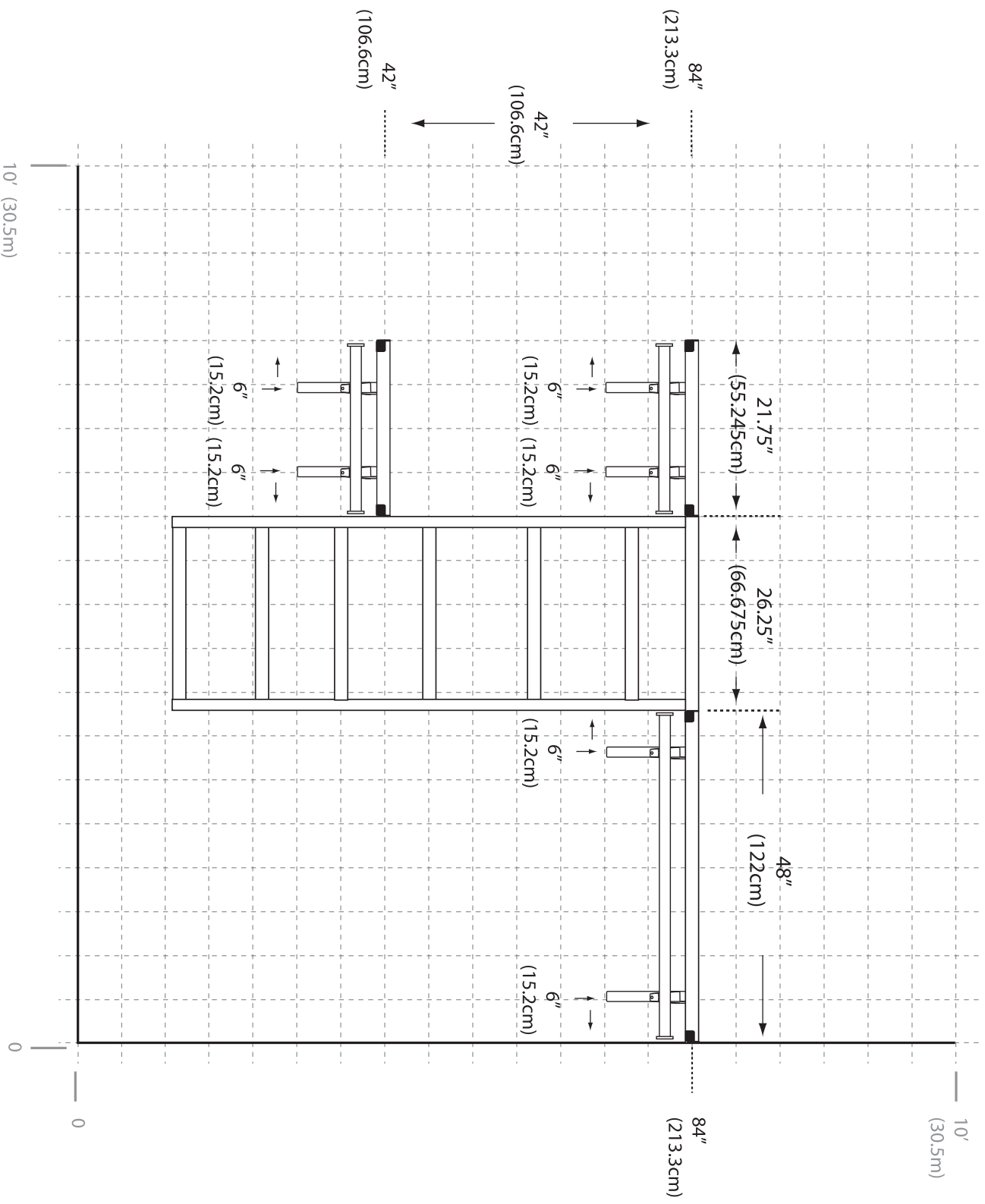

8' CONFIGURATION D **D CONFIGURACIÓN DE 2.5 M** **D CONFIGURATION DE 2.44 M**

= 6" (15.2cm)

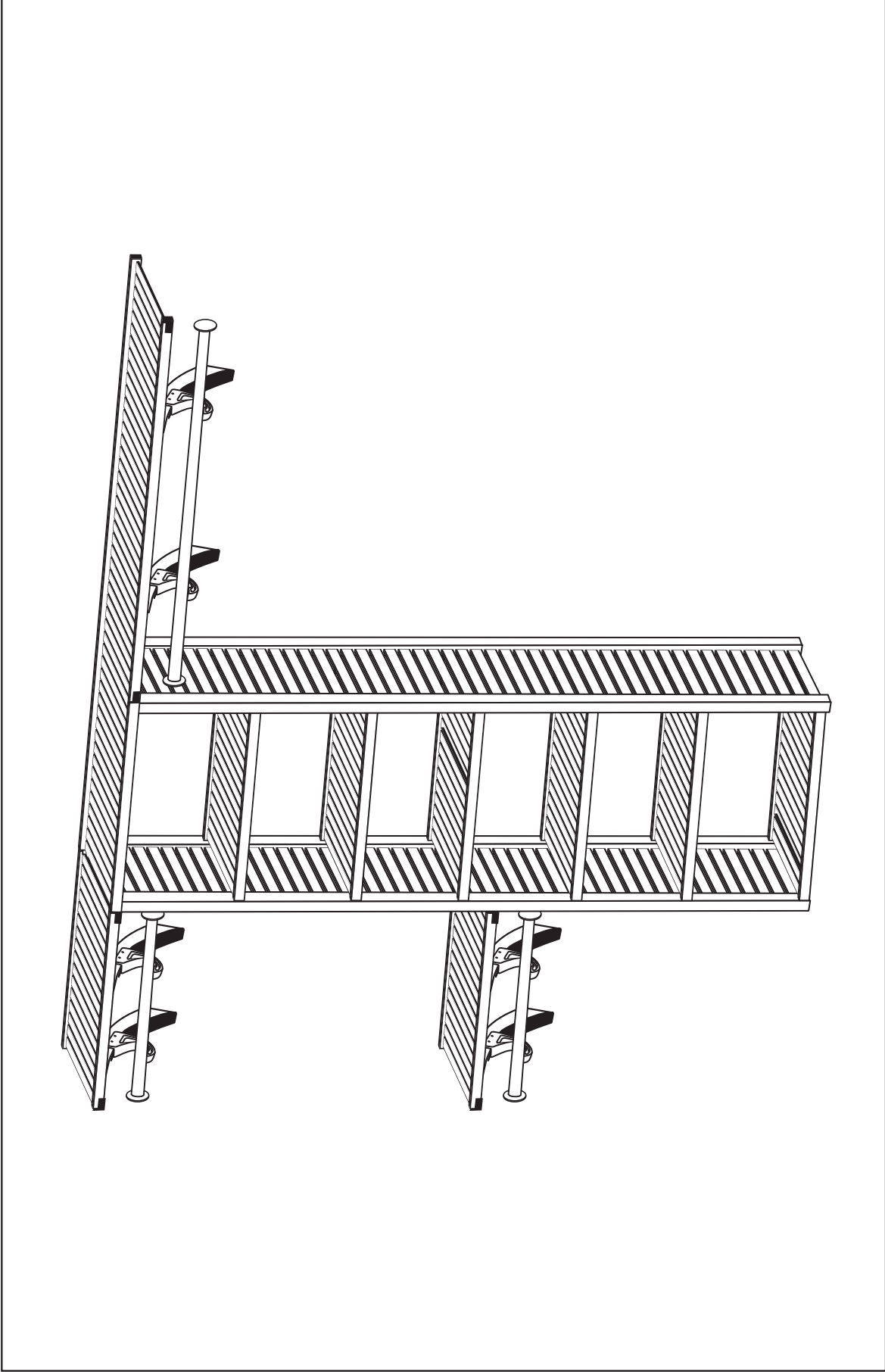

8' CONFIGURATION D D CONFIGURACIÓN DE 2.5 M D CONFIGURATION DE 2.44 M

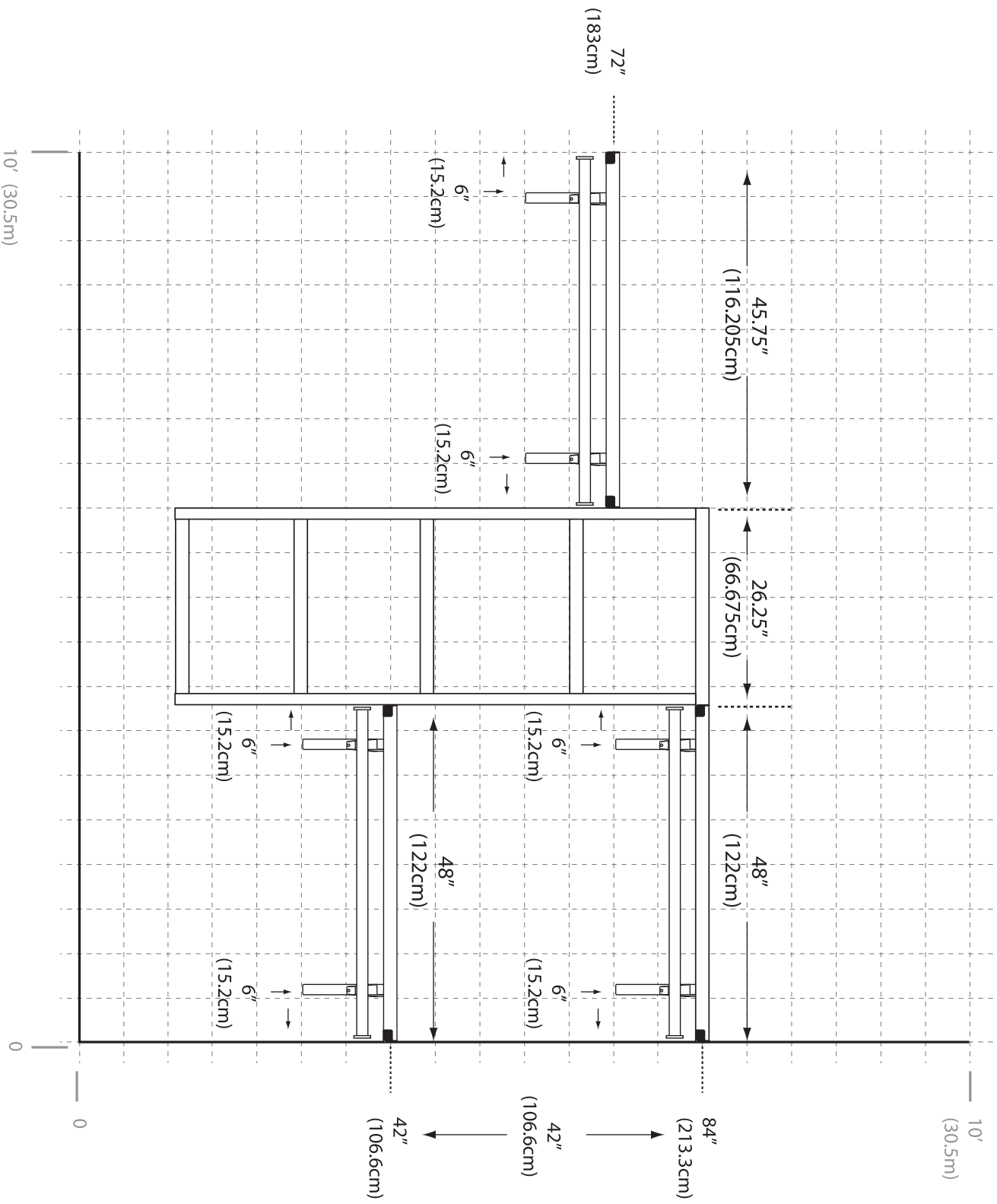

10' CONFIGURATION A A CONFIGURACIÓN DE 3.05 M A CONFIGURATION DE 3 M

= 6" (15.2cm)

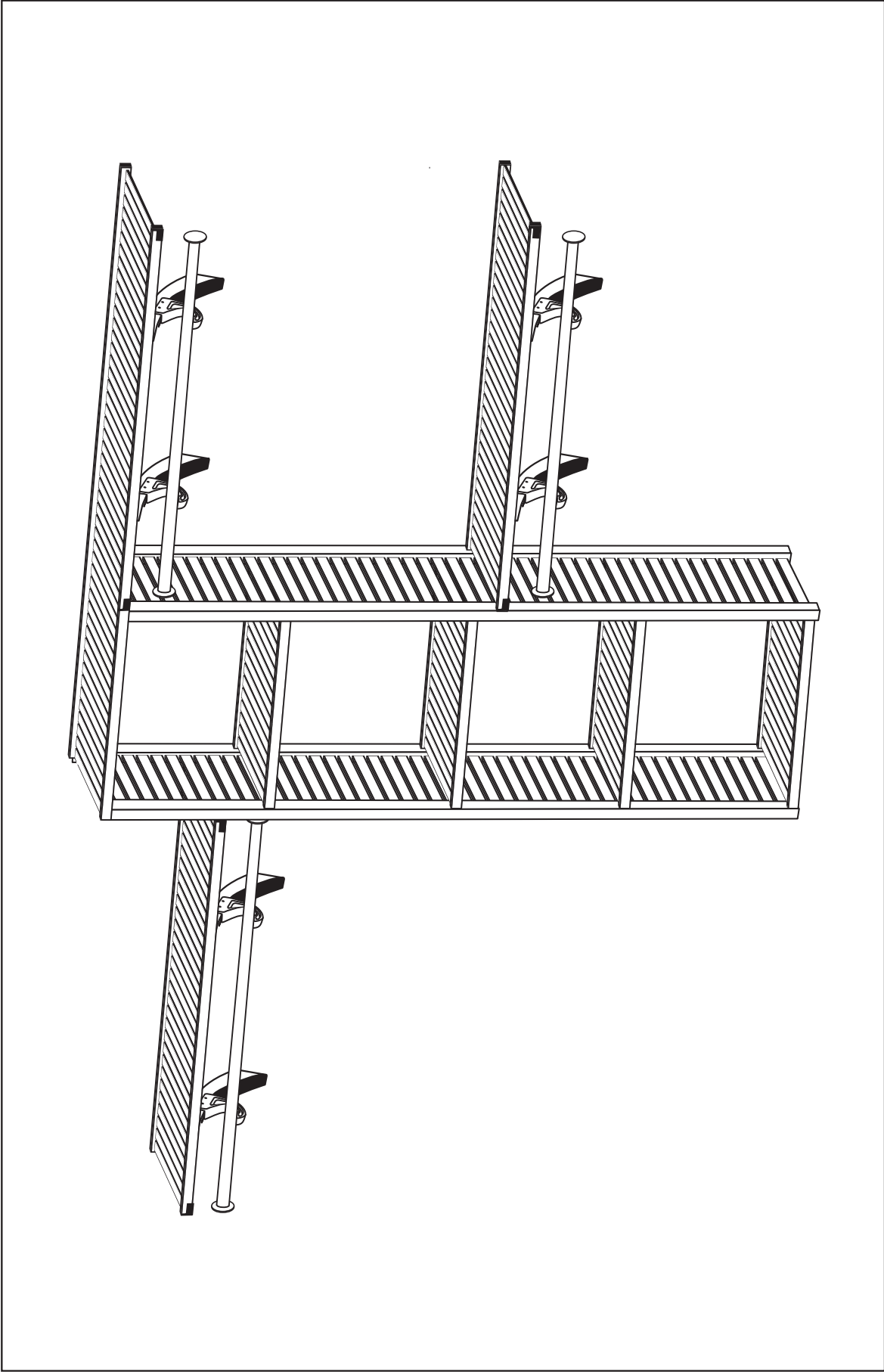

10' CONFIGURATION A A CONFIGURACIÓN DE 3.05 M A CONFIGURATION DE 3 M

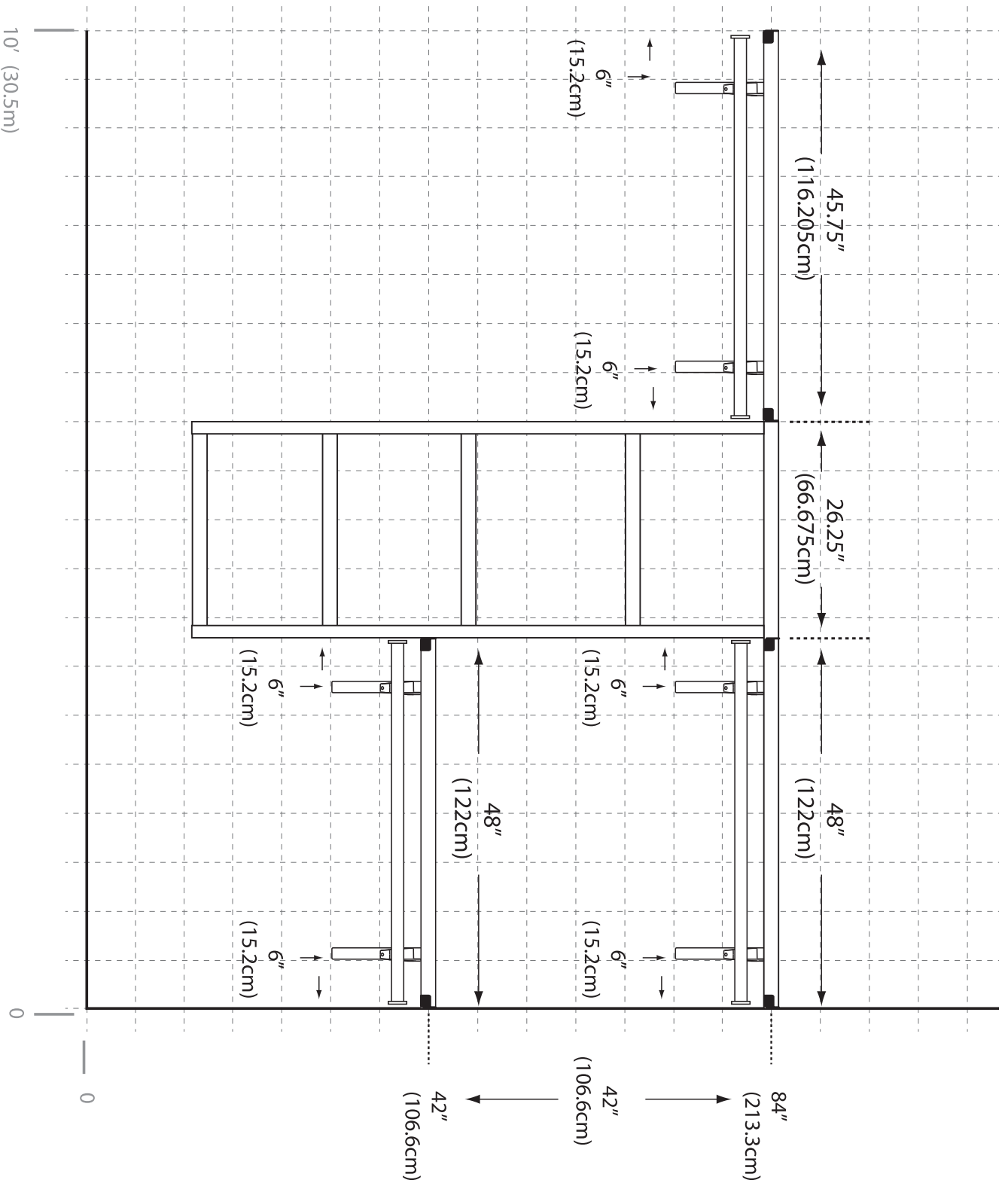

10' CONFIGURATION B B CONFIGURACIÓN DE 3.05 M B CONFIGURATION DE 3 M

6" = 15.2cm

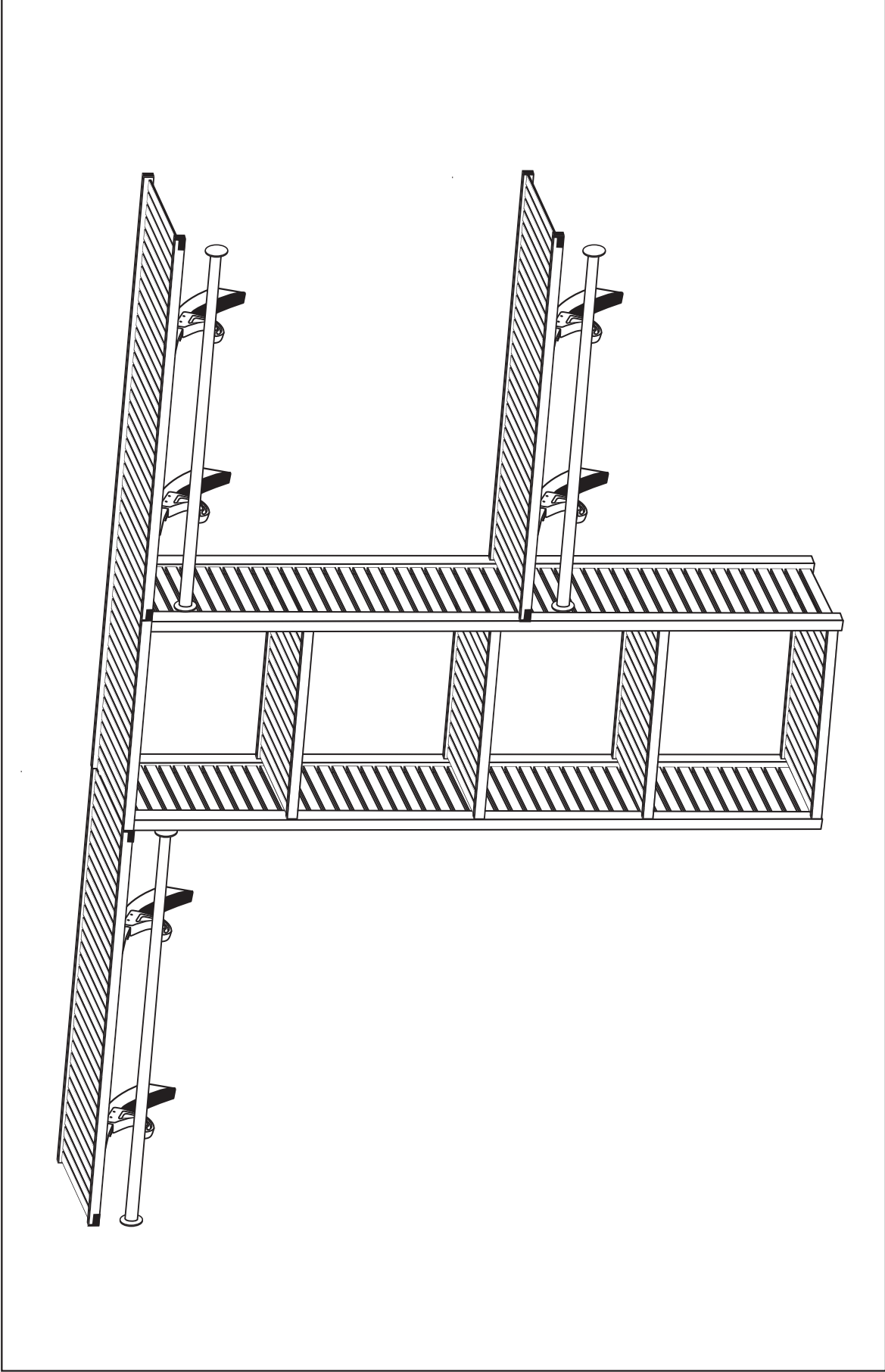

10' CONFIGURATION B B CONFIGURACIÓN DE 3.05 M B CONFIGURATION DE 3 M

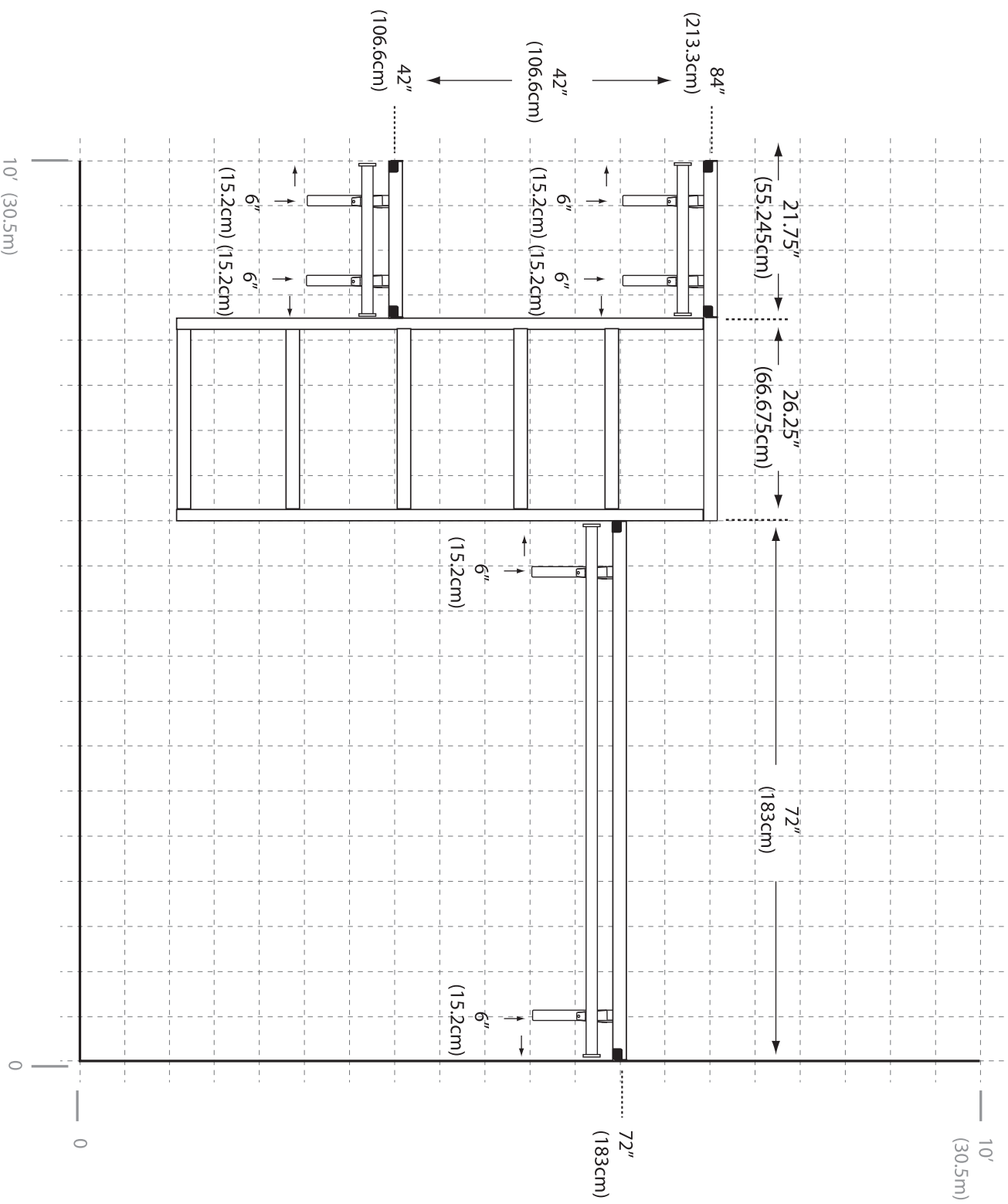

10' CONFIGURATION C C CONFIGURACIÓN DE 3.05 M C CONFIGURATION DE 3 M

■ = 6" (15.2cm)

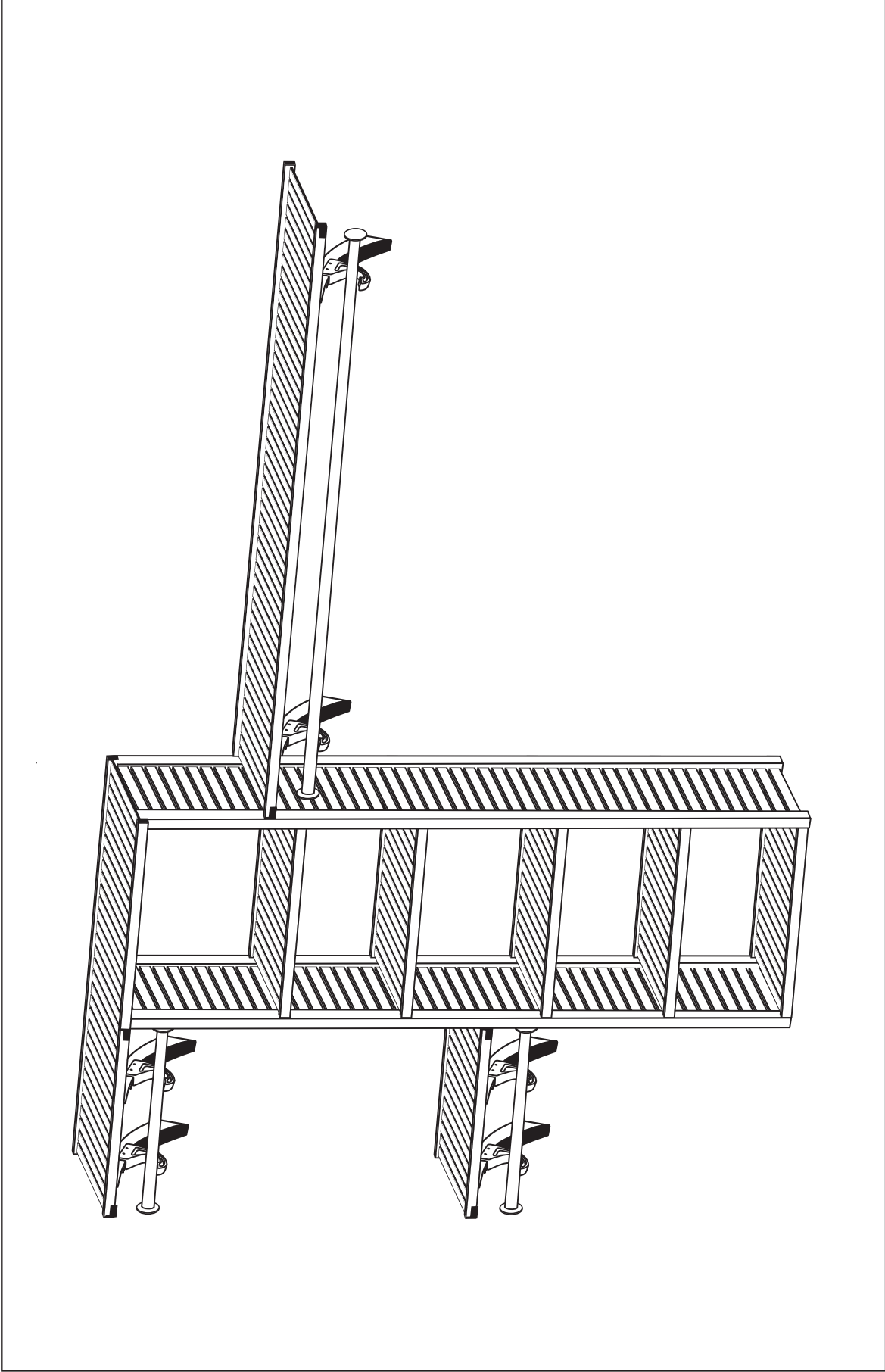

10' CONFIGURATION C C CONFIGURACIÓN DE 3.05 M C CONFIGURATION DE 3 M