

MI TOWER



MI TOWER ASSEMBLY GUIDE (Rev.02 07-02-2020)



+44 (0)1244 833 933



info@popupproducts.co.uk



popupproducts.co.uk



ASSEMBLY GUIDE FOR MITOWER

CONTENTS

CONTENTS	1	GETTING STARTED	11
INTRODUCTION	2	MITOWER 2M - ASSEMBLY	12
KNOW YOUR MITOWER	3	MITOWER 2M - ASSEMBLY	13
KNOW YOUR MITOWER'S COMPONENTS	4	MITOWER 3M - ASSEMBLY	14
KNOW YOUR KIT LIST AND SPECIFICATIONS	6	MITOWER 3M - ASSEMBLY	15
KNOW YOUR STORAGE AND TRANSPORT PACK	7	MITOWER 4M - ASSEMBLY	16
SAFETY DOS AND DON'TS - ALWAYS	8	MITOWER 4M - ASSEMBLY	17
SAFETY DOS AND DON'TS - NEVER	9	10 POINT PRE-USE SAFETY CHECKLIST	18
BEFORE YOU START	10	REGISTRATIONS	20

INTRODUCTION

MI TOWER is a versatile and high quality tower providing a work platform for one person. It is designed in accordance with the latest testing and quality standards.

Our priority is to help ensure the safe operation of our products, so please pay particular attention to the safety tips on pages 7 and 8.

We want you to enjoy the safe and responsible use of MI TOWER with the minimum of fuss and this guide is designed to get you up and running as quickly and as safely as possible.

We recommend that you read this guide prior to assembling and using your MI TOWER.

Scan this QR code to view the video of MI TOWER in operation.



www.popupproducts.co.uk/videos/mitower

Visit PASMA and HSE for further reference.

KNOW YOUR MI TOWER

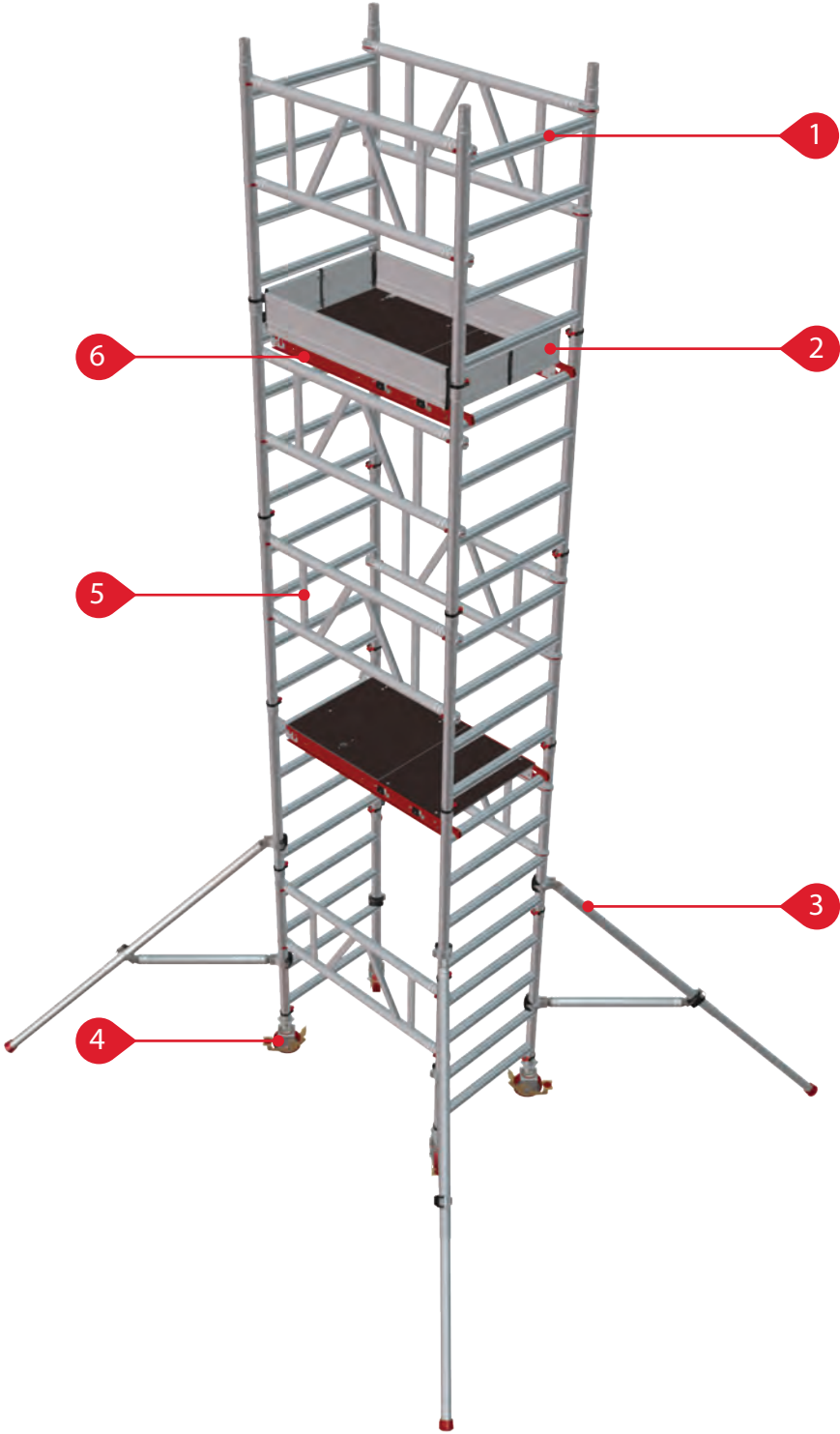

PARTS LISTING

1	4 RUNG FRAME	4	ADJUSTABLE LEG AND CASTOR
2	TOE BOARD	5	GUARDRAIL BRACE PANEL
3	TELESCOPIC STABILISER	6	HATCH PLATFORM

KNOW YOUR MI TOWER COMPONENTS



1 GUARDRAIL BRACE PANEL

Claws are fitted to the guardrail brace panels and each has an automatic locking jaw which is released by simply moving the jaw's trigger. The claw must only be attached to the frame with the opening facing outward. Attachment with the jaw's opening facing inward will not fully protect the user if lent upon and may cause serious injury or death. Always ensure that each claw is positively locked in position before using your tower.

2 FRAME CLIPS

The frame clip's pin locates into a retaining hole in the frames to lock tower sections together when placed one on top of the other. The pin is locked in place by a red tab to ensure that it remains in place. From the disengaged position, pivot the pin / tab to bring the pin horizontal. Insert the pin fully through the retaining hole with its tail pointing down. Next flip the tab vertically to lock the pin in place. Removal is simply a reversal of the fitting sequence.

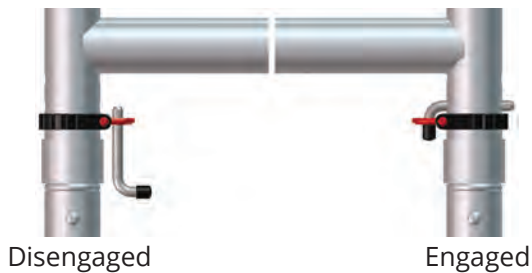

3 STABILISER COUPLER CLAMP

The coupler clamps are used to secure the stabilisers to the tower's vertical tubing. With the clamp jaw open, offer it to the tube. Bring the jaw around the tube and set the buckle on to the hook, then close the clamp arm to lock the stabiliser in position. A similar clamp is fitted to the stabiliser extension leg.

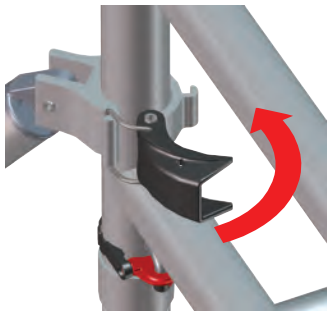

4 WIND-LOCK CATCH

The wind lock catches comprise of a set of auto-engaging hooks at one end of the platform and a single gravity type catch at the other. The purpose of these devices is to prevent up-lift of the platforms in windy conditions. To engage the auto wind lock (AWL) simply tilt the platform at the angle shown before placing the hooks onto the rung of the end frame. Lower the opposite end of the platform onto the opposite end frame rung and the gravity type lock will automatically engage. Simply lift and hold the gravity lock before tilting the platform to dis-engage the opposite AWL hooks when removing the platform on tower disassembly.



5 PLATFORM WITH BUILT IN COMPONENT HANGERS

To enable one man to erect MI TOWER products, each hatch is fitted with four component hangers which are stowed (two either side) within the platform's frame. The hangers can be extended when needed and retracted when not.

To extend a hanger simply pull up the friction clip and pull the component hanger until it stops. To retract the hanger, simply reverse the procedure.

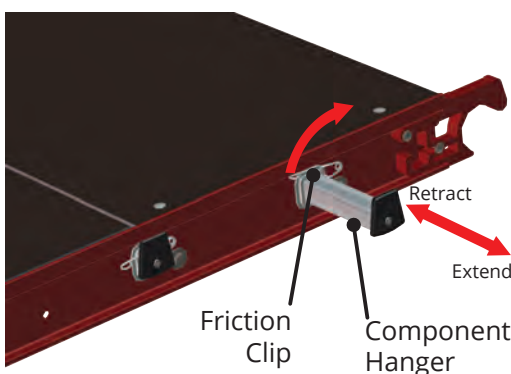

KNOW YOUR MI TOWER COMPONENTS

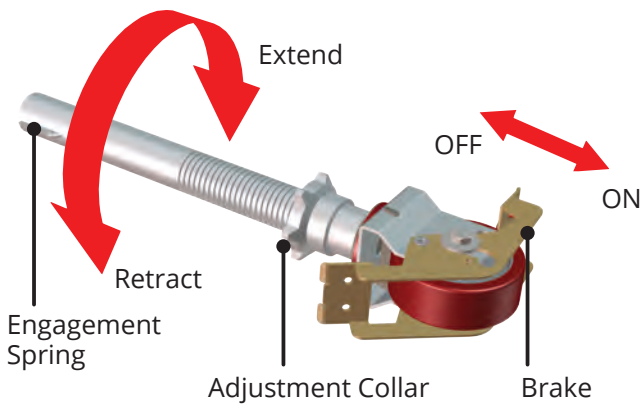

7 ADJUSTABLE LEG AND CASTOR

The adjustable leg and castor allows for accurate positioning of your MI TOWER in relation to your workplace. The leg can be extended or retracted to allow for levelling and the brake must be applied to prevent movement.

KNOW YOUR KIT LIST AND SPECIFICATIONS

COMPONENT MATRIX AND WEIGHTS

GROUND CONDITIONS	Weight (Unit) kg	2m qty	3m qty	4m qty
4 RUNG FRAME	3.58	6	8	10
TELESCOPIC OUTRIGGER	3.58	4	4	4
HATCH PLATFORM	8.56	1	2	2
GUARDRAIL BRACE PANEL	3.34	4	6	7
220MM ADJUSTABLE LEG	0.85	4	4	4
125MM LOCKING CASTOR	2.50	4	4	4
TOE BOARD SET	5.33	1	1	1
MITOWER WEIGHT (KG)		76.45	98.85	109.35
PLATFORM SAFE WORKING LOAD		150kg	150kg	150kg

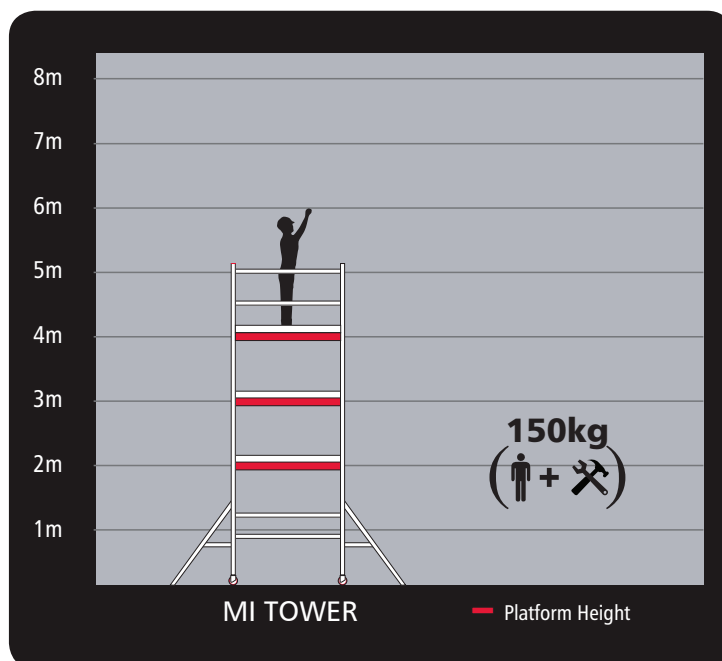

KNOW YOUR STORAGE AND TRANSPORT PACK

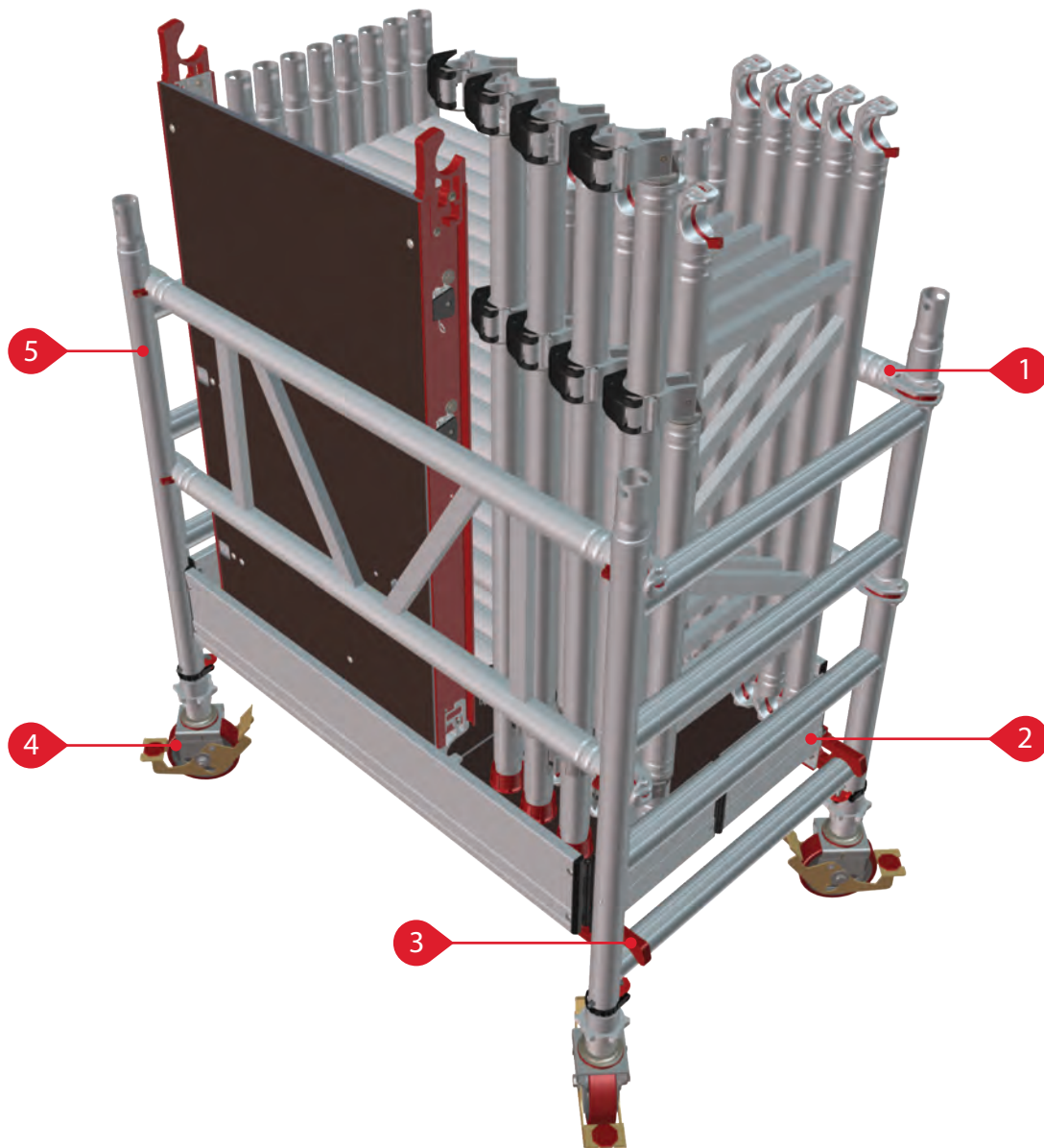

TRANSPORT AND STORAGE

For ease of storage and of transportation, MI TOWER has been designed so that all components can be safely stored within the tower's base assembly. See illustration.

TROLLEY COMPONENTS

- 1 GUARDRAIL BRACE PANEL X2**
- 2 TOE BOARD SET**
- 3 HATCH PLATFORM**
- 4 ADJUSTABLE LEG AND CASTOR X4**
- 5 4 RUNG FRAME X2**

SAFETY DOS AND DON'TS - ALWAYS

- ALWAYS** Read and understand this guide before you begin assembly.
- ALWAYS** Ensure that all safety requirements are met and that MI TOWER is the correct access solution for the task you wish to perform.
- ALWAYS** Ensure that MI TOWER is assembled and dismantled by a qualified, competent person.
- ALWAYS** Cordon off the work area creating a zone with a radius that is 1m greater than the total height of MI TOWER.
- ALWAYS** Wear the correct Personal Protective Equipment for the task being performed. Gloves, steel toecap boots, a hard hat and suitable clothing must be worn by all persons.
- ALWAYS** Tie back long hair and remove items of loose jewellery.
- ALWAYS** Perform a full risk assessment prior to assembling or using MI TOWER and abide by your findings.
- ALWAYS** Prevent access to unauthorised persons if you have no other option but to leave MI TOWER unattended and if this is not possible then MI TOWER must be dismantled.
- ALWAYS** Carry tools and materials safely retained in a tool belt that allows freedom of movement.
- ALWAYS** Ensure you properly assess the risk/method if tools or materials are hoisted to the platform via a rope.
- ALWAYS** Access platforms from within MI TOWER and via the 4 rung frames positioned at the platform's trap door end. Keep your feet in the middle of the rungs and grip the upper rungs with your hands.
- ALWAYS** Erect MI TOWER on smooth level ground that is capable of supporting its own weight, the user and any tools or materials without subsidence.

SAFETY DOS AND DON'TS - NEVER

- NEVER** Use MI TOWER if you don't understand something in this guide; please contact the supplier for advice.
- NEVER** Assemble, use, move or dismantle MI TOWER if you are tired or unwell or if you are under the influence of alcohol or drugs.
- NEVER** Use MI TOWER in adverse weather conditions which may endanger the user.
- NEVER** Use in wind conditions of Beaufort Force 5 and above. Please be aware of the tunnel effect caused by buildings close to each other.
- NEVER** Assemble or use MI TOWER near overhead hazards such as power lines that are within reach of MI TOWER or the user.
- NEVER** Ascend or descend your MI TOWER if both hands are not free.
- NEVER** Add banners, notice boards, etc. to MI TOWER.
- NEVER** Use MI TOWER if contaminated by paint, chemicals, etc.
- NEVER** Overload the platforms (see component matrix page 5).
- NEVER** Suspend MI TOWER from another structure.
- NEVER** Lean from MI TOWER and never apply undue side force.
- NEVER** Stand on the guardrails, toe boards, boxes (or similar) to gain extra height. If the working height is insufficient either construct MI TOWER to the required height or use an alternative method.
- NEVER** Use damaged components in your MI TOWER assembly.

BEFORE YOU START

PREPARATION

The floor area must be clear of any obstructions including materials and debris. Check that you have all the components necessary to construct the tower height you require. Check also each component for condition and correct function. If any part is missing or damaged/not working correctly it must be replaced before assembling

3T (THROUGH THE TRAPDOOR) SYSTEM

The 3T method of construction has been developed to reduce the risk of an erector falling from a tower during construction. The erector must sit on the platform with legs through the hatch and feet on the frame rungs when attaching guardrail brace panels above the platform. This ensures the erector is always protected by a set of guardrail brace panels.

TYING IN

You should consider tying in the tower to add stability, but this may only be carried out by a suitably trained person.

BALLAST

Where shown in the component list, ballast must be used to stabilise against overturning. Only use solid materials as ballast (i.e. no loose materials) and position to avoid overloading individual components. Ballast should be supported by the base of your MI TOWER and securely fastened to prevent removal.

ASSEMBLY GUIDE

These instructions must always be made available to the user. If replacement copies are required, please contact your supplier.

DAMAGED COMPONENTS

Regularly inspect all components for damage. Damaged components must be quarantined so that they cannot be used. Where safe to do so, the component can be repaired but only by a qualified repairer. If in doubt contact your supplier for advice.

DISMANTLING YOUR MI TOWER

MI TOWER is easily dismantled by simply reversing the erection procedure. Make sure that the component hangers are evenly loaded to ensure your MI TOWER remains balanced. You must, however, be protected by guardrail brace panels when standing on any platform and ensure that you use the 3T method when removing guardrail brace panels.

GETTING STARTED

GETTING STARTED

MI TOWER requires only one person to assemble and dismantle it. Your MI TOWER is supplied with uniform 1m high rung frames which can be used at any stage of the assembly. During erection, the frames may be connected together to create 2m high frames which makes assembly both quicker and easier.

STABILISERS POSITIONING

Stabilisers are supplied and must be used for all MI TOWER heights.

For maximum effect arrange the stabilisers by positioning at an angle of 45 degrees to give a footprint as close to square as possible, as shown in fig. 1.

If the tower is to be positioned against a wall, the stabiliser footprint can be altered as shown in fig. 2 but only where the heights of the wall is a minimum of two thirds the height of the top working platform.

Ensure that all four stabilisers' feet are in contact with the ground and that the ground can support the weight of the tower and stabilisers.

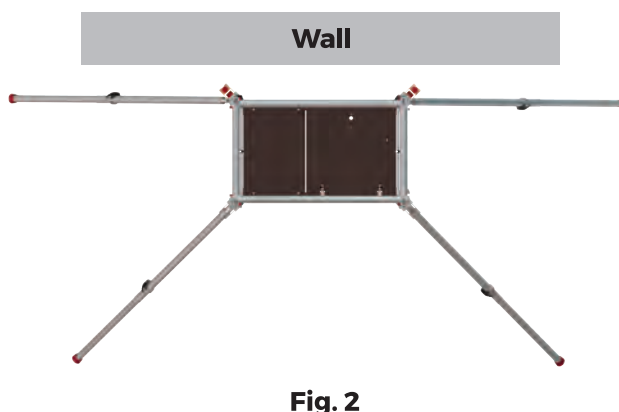
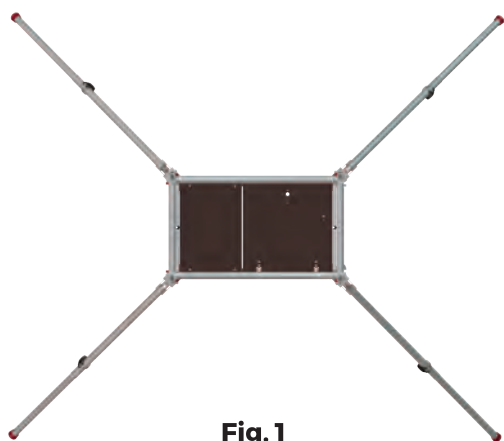

MOVING YOUR MITOWER

When your MI TOWER needs to be moved a small distance to enable you to continue your task, this can be achieved provided the stabilisers can remain in pattern and all tools, materials and personnel are removed from the tower.

You will need to raise the stabilisers so that they are no more than 25mm above the floor and properly locked. However, if the stabilisers have to be repositioned and this reduces the footprint, your MI TOWER must be reduced in height to 2m.

You must only move MI TOWER by manual effort, at a slow pace and only after fully assessing the risk. Once moved, always check MI TOWER before using.

If MI TOWER is to be moved to a new location, a new level or over rough terrain, it must be fully dismantled and rebuilt at the new location.

MI TOWER 2m - ASSEMBLY

STEP 1

Fully insert the adjustable legs with castors into two frames, turning the leg's height adjustment collar to bring each leg 25mm from the lowest position.

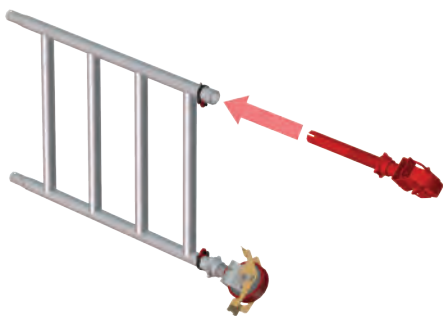

STEP 2

Attach a guardrail brace panel to the vertical tube of one frame with the upper claw positioned above the fourth rung and with all claws facing outward. Make sure the claws are correctly locked on to the frame tube. Now attach the second frame to the guardrail brace panel to create the base frame assembly. Lock all four castors and using a spirit level as a guide, adjust each leg to bring the base square and level.



STEP 3

Construct two sets of conjoined frames, these will give you two 2m sections and will speed up the erection process. Release the frame clips on one four rung frame and fit it on to a second four rung frame. Apply the frame clips and ensure they are correctly locked. Repeat this with the second set. Fit one set of conjoined frames to a base frame and apply the frame clips. Repeat this with the second set. Fit one set of conjoined frames to a base frame and apply the frame clips. Repeat this with the second set.

STEP 4

Next, attach one guardrail brace panel with its lower jaw positioned above the sixth frame rung. It must be fitted on the opposite side to the first guardrail brace panel to ensure stability. Ensure all claws are facing outward and correctly locked on to the frame tube.

MI TOWER 2m - ASSEMBLY

STEP 5

Stand inside the tower and fit a platform on to the eighth rung, making sure that the wind-lock catches engage.



STEP 6

Fit a stabiliser to each corner of the tower. Position the lower horizontal stabiliser coupler clamp just above the frame's second rung, then secure the top stabiliser coupler clamp just above the frame's fifth rung. Adjust the stabilisers so that you create as square a footprint as possible. Adjust each stabiliser's length so that they are in contact with the ground. Make sure all coupler clamps are correctly secured. Extend and lock the four component hangers located on either side of the platform.



STEP 7

Place two guardrail brace panels on to one set of hangers, and the toe boards in to the opposite set. Enter the tower framework and climb the frame rungs until you are half way through the platform's trap door. Now manoeuvre yourself so that you are sitting on the platform, with your legs through the trap door and your feet on the frame rungs. From this position, you should take each of the guardrail brace panels, one at a time, and attach so that the upper jaws are positioned above the twelfth rung.



STEP 8

With both panels in position, you may access the platform. Unfold the toe board set and position so that they sit on to the outer edge of the platform. Finally, retract all hangers and the tower is now complete and ready to use.



MI TOWER 3m - ASSEMBLY

STEP 1

Replicate step 1 from 2m assembly. Attach a guardrail brace panel to the vertical tube of one frame with the lower claw positioned above the second rung and with all claws facing outward. Make sure the claws are correctly locked on to the frame tube. Now attach the second frame to the guardrail brace panel to create the base frame assembly. Lock all four castors and using a spirit level as a guide, adjust each leg to bring the base square and level.



STEP 2

Fit a single 1m frame to a base frame and apply the frame clips. Fit a second 1m frame to the other base frame.



STEP 3

Fit a platform on to the fourth rung, making sure that the wind-lock catches engage. Next, attach a pair of guardrail brace panels opposite each other with their upper jaws positioned above the eighth frame rung. Ensure all claws are facing outward and correctly locked on to the frame tube.

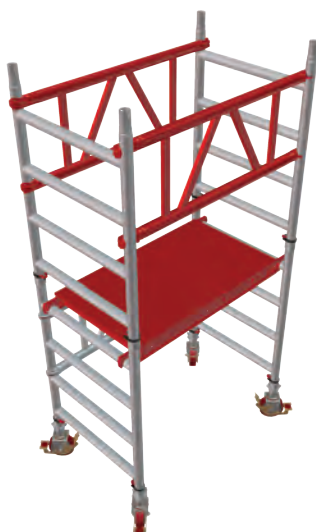

STEP 4

Fit a stabiliser to each corner of the tower. Position the lower horizontal stabiliser coupler clamp just above the frame's second rung, and then secure the top stabiliser coupler clamp just above the frame's fifth rung. Adjust the stabilisers so that you create as square a footprint as possible. Adjust each stabiliser's length so that they are in contact with the ground. Make sure all coupler clamps are correctly secured.

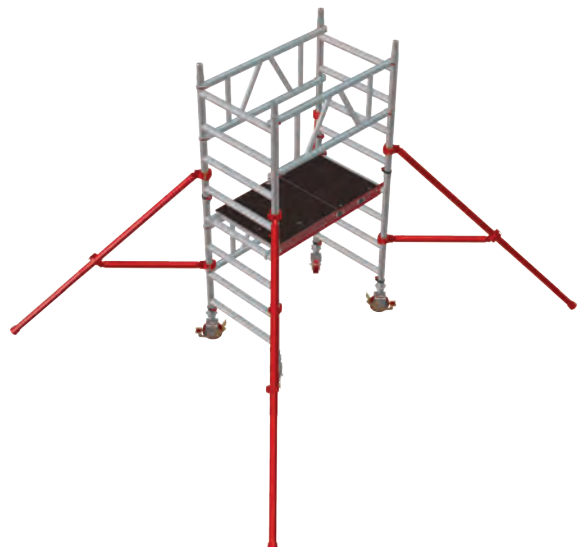

MI TOWER 3m - ASSEMBLY

STEP 4

Construct two sets of conjoined frames, these will give you two 2m sections. Release the frame clips on one four rung frame and fit it on to a second four rung frame. Apply the frame clips and ensure they are correctly locked. Repeat this with the second set. Place the conjoined frames one at each end of the tower ready to be fitted. Extend and lock the four component hangers located on either side of the first platform.



STEP 5

Place a guardrail brace panel on to a component hanger on one side of the platform and a second platform on the other side. Access the first platform. Fit one set of conjoined frames to each end of the tower and apply the frame clips. Next, attached the guardrail brace panel with its lower jaw positioned above the tenth frame rung. Ensure all claws are facing outward and correctly locked on to the frame tube. Now carefully fit the second platform on to the twelfth rung, making sure that the wind-lock catches engage. Extend and lock the four component hangers located on either side of the platform. Descend the tower and from the ground place two guardrail brace panels onto the hangers on one side of the second platform and a set of toe boards on the other side.



STEP 6

Access the tower until you are half way through the second platform's trap door. Now manoeuvre yourself so that you are sitting on the platform, with your legs through the trap door and your feet on the frame rungs. From this position, you should take each of the guardrail brace panels, one at a time, and attach so that the upper jaws are positioned above the sixteenth rung.



STEP 7

With both panels in position, you may access the platform. Unfold the toe board set and position so that they sit on to the outer edge of the platform. Finally, retract all hangers and the tower is now complete and ready to use.



MI TOWER 4m - ASSEMBLY

STEP 1

REPLICATE STEPS 1 - 6 FROM 2M ASSEMBLY.

Place three guardrail brace panels on to one set of hangers and a pair of eight rung conjoined frames to the other side. Enter the tower framework and climb the frame rungs until you are half way through the platform's trap door. Now manoeuvre yourself so that you are sitting on the platform, with your legs through the trap door and your feet on the frame rungs. From this position, you should take a guardrail brace panel, one at a time, and attach so that the upper jaws are positioned above the twelfth rung. With both panels in position, you may access the platform.

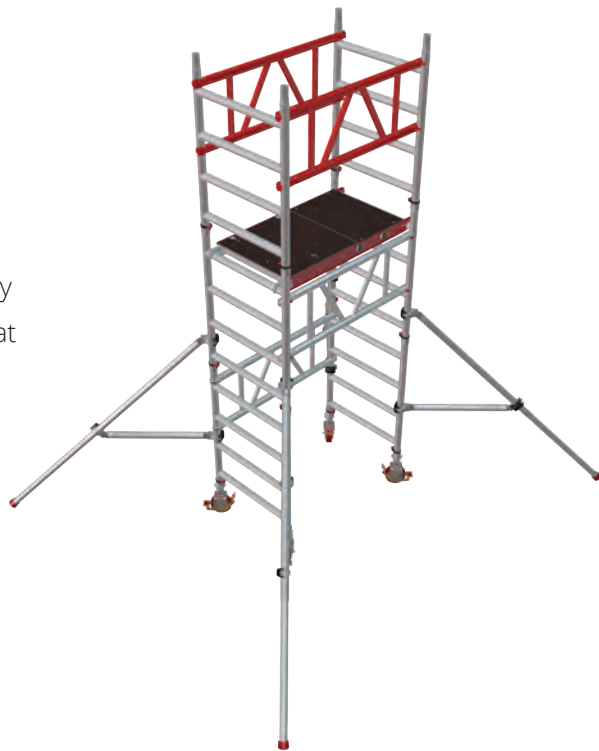

STEP 2

Fit one set of conjoined frames to each end of the tower and apply the frame clips. Next, attach the guardrail brace panel with its lower jaw positioned above the fourteenth frame rung. Ensure all claws are facing outward and correctly locked on to the frame tube. Descend the tower and from the ground place two guardrail brace panels onto the hangers on one side of the platform then a set of toe boards and a platform on the other side.



MI TOWER 4m - ASSEMBLY

STEP 3

Access the tower then carefully fit the second platform on to the sixteenth rung, making sure that the wind-lock catches engage. Extend and lock the four component hangers located on either side of the platform. Transfer the two guardrail brace panels and the set of toe boards to the component hangers on the second platform.



STEP 4

Position yourself so that you are half way through the second platform's trap door. Now manoeuvre yourself so that you are sitting on the platform, with your legs through the trap door and your feet on the frame rungs. From this position, you should take each of the guardrail brace panels, one at a time, and attach so that the upper jaws are positioned above the twentieth rung.



STEP 5

With both panels in position, you may access the platform. Unfold the toe board set and position so that they sit on to the outer edge of the platform. Finally, retract all hangers and the tower is not complete and ready to use.

INTERMEDIATE WORK PLATFORMS

Any platform fitted to the tower at any stage may be used as a work platform, provided toe boards and guardrail brace panels are fitted.



10 POINT PRE-USE SAFETY CHECKLIST

10 POINT PRE-USE CHECKLIST FOR USERS

1	BEFORE USE	Completed tower must be checked by a competent person.
2	COMPONENTS	Check all components are free from damage.
3	CASTORS	Ensure they are locked.
4	ENVIRONMENT	Check your MiTOWER is level.
5	STABILISER COUPLER CLAMPS	Check they are secure.
6	GUARDRAILS	Make sure all platforms are fully enclosed by guardrails.
7	BRACE CLAWS	Check they are locked correctly.
8	WINDLOCK CATCHES	Make sure they are engaged.
9	FRAME CLIPS	Make sure they are engaged.
10	TOE BOARDS	Check they are correctly positioned on all platforms.

REGISTRATIONS

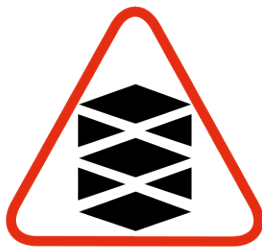

PASMA
Member

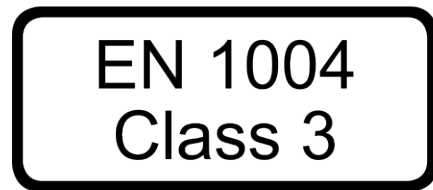

ISO9001 : 2008
Certificate No.FM 513133





popupproducts.co.uk

+44 (0)1244 833 933

info@popupproducts.co.uk