

BOSS[®]



LIFTSHAFT⁷⁰⁰

Camlock Guardrail
Aluminium Tower
3T - Through the Trapdoor Method

USER GUIDE

Contents

Safety First	2
Component Diagram	10
Quantity Schedule	11
Build Method	12
Pre-use Safety Inspection Checklist	19

Safety First

Introduction

**Please read this user guide carefully.
Please note that diagrams are for illustrative purposes only.
User guides are also available to download from our website at bossacesstowers.com.**

BoSS mobile aluminium towers are light-weight scaffold towers used throughout the building and construction industry for both indoor and outdoor access solutions where a stable and secure platform is required. Ideal for maintenance and installation work or short-term access, the highly versatile towers provide a strong working platform for a variety of heights.

This user guide provides you with step by step instructions to ensure your system is erected easily and safely, using the 3T (Through The Trapdoor) method.

The law requires that personnel erecting, dismantling or altering towers must be competent. Any person erecting a BoSS mobile tower must have a copy of this user guide. For further information on the use of mobile access and working towers consult the PASMA operators code of practice.

If you need further information, design advice, additional user guides or any other help with this product, please contact the manufacturer on **+44 (0)1621 745900** or email uk.customer@wernerco.com.

Compliances

User Guide EN1298-IM-en.

Tower approved for*:	
Internal Use	External Use
YES	NO

*Platform heights up to 20.2m

Safety First

Safe use

- Check overhead that the area into which the structure is to be erected contains no obstructions, particularly electrical or radio radiation hazards.
- Ensure the ground on which the mobile access tower is to be erected is capable of supporting the tower.
- **The tower has a single working level with a safe working load of 275kg. All platforms may be used for working, but only one should be used at any one time.**

Before each use:

- Check that each prefabricated tower scaffold is complete and correctly assembled.
- Check that the prefabricated tower scaffold is vertical and make any adjustments as required.
- Check that no environmental changes will affect the safe use of the structure.
- Adjustable legs should only be used for levelling.
- Do not use ladders, steps, boxes or similar to gain additional working height.
- Tower scaffolds are not designed to be lifted or suspended.
- Beware of horizontal forces (e.g. power tools) which could generate instability.
Maximum horizontal force per working bay = 30kg
- Tools and materials should be lifted using a reliable lifting material (e.g. a strong rope), employing a reliable knot (e.g. clove hitch), to ensure safe fastening and always lift within the footprint of the prefabricated tower scaffold.
- Safe working loads, (normally expressed in kN/m²) are expressed on page 4 in kg per defined working area.

Safety First

Safe use

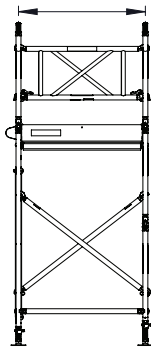

Defined working area	Max. safe working load (uniformly distributed including persons)	Load class	Max no. of persons*
A	275kg	3	1

* Persons are assumed to be 122kg
(Reference to HSE - Revision of body size criteria in standards Protecting people who work at height - Research report 342)

Access classes

The Access Class provided for climbing this tower is: Access Class 'D' (Vertical Ladder).

Lifting of individual tower components

- Raising and lowering components, tools and/or materials by rope should be conducted within the tower base (i.e. within the area bounded by the stabilisers). Ensure that the safe working load of the supporting decks and the tower structure is not exceeded.

Movement of the assembled prefabricated tower scaffold

- The BoSS LiftShaft⁷⁰⁰ tower system **MUST NOT** be moved once erected.
- Always dismantle it and rebuild at the new location.
- The pre-use checklist on the final page shall be used to determine tower integrity.

Safety First

Maintenance - Storage - Transport

- All components and their parts should be regularly inspected to identify damage, particularly to joints. Lost or broken parts should be replaced and any tubing with indentation greater than 5mm shall be replaced. Adjustable leg threads should be cleaned and lightly lubricated to keep them free running.
- Brace claws, frame interlock clips, trapdoor latches, camlocks and platform wind-locks should be regularly checked to ensure they lock correctly.
- Refer to the BoSS Inspection Manual for detailed inspection and maintenance advice at: **www.bossacesstowers.com**
- Components should be stored in clean, dry conditions with due care to prevent damage.
- Ensure components are not damaged by excessive strapping forces when transported.

During assembly, use and dismantling

- As part of the risk assessment, wind conditions must be taken into account and reviewed regularly, depending on the duration that the structure is onsite.
- The structure has been assessed for wind loads equating to 27 mph (43 kph, 12 m/s).
- The effect of onsite wind conditions must be considered prior to the assembly of a tower. The tower must not be used in wind speeds above this. If greater wind speeds are forecast, the tower must be dismantled while it is still safe to do so.
- Sheets, tarpaulins, cladding or similar, must not be attached to the tower as these will significantly increase any side loads from wind and will potentially make the tower unstable.
- Beware of wind turbulence and funnelling effects around buildings.
- Excessive side loads from working on the tower, i.e. drilling or pulling may also make a tower unstable. The maximum allowable side load on a tower is 30kg.

Safety First

- Do not abuse equipment. Damaged, incorrect or incompatible components should not be used.

CAUTION:

Always ensure the portal ladder is in closed position when descending the tower. If the portal ladder is in open position, from the protected position of the trapdoor deck (i.e. seated), close the portal ladder ensuring the locking claw has been fully engaged.

Ties

This structure is designed to be self-supporting under the loading condition requirements of BS 1139-6:2014 and does not require tying in. Consideration should be given to potential wind conditions if the tower is left unattended - see 'Assembly, Use and Dismantling' section on page 5.

Safety First

Props

The BoSS LiftShaft⁷⁰⁰ tower shall be adequately propped or tied to prevent lateral movement. They must be fitted at regular 4.0m intervals. To improve stability, additional props or ties can also be fitted at lower levels.

The method shown below illustrates the use of BoSS Confined Space Stabilisers.

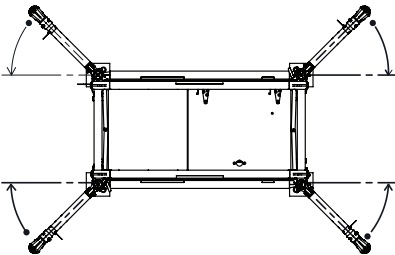
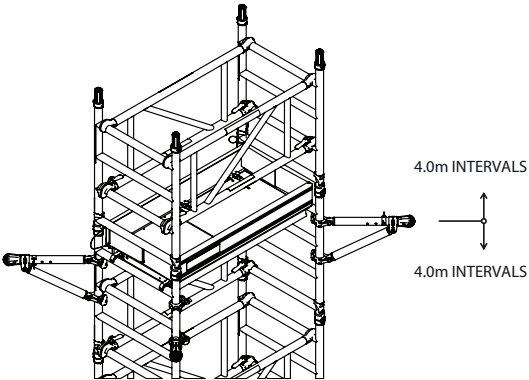

Attach one confined space stabiliser to each corner of the tower as shown (see page 16). Ensure stabiliser feet are touching the lift shaft walls - adjust confined space stabilisers as necessary to achieve this.

If you require further advice, please contact please contact the manufacturer on +44 (0) 1621 745900.

Safety First

Assembly procedure

This tower structure must be assembled and components oriented in accordance with this document. Deviation from this instruction is not permitted.

A minimum of two persons are recommend for assembly and disassembly of this prefabricated tower structure. The maximum number of persons for assembly is stated in the safe loading table. Platforms must be installed with vertical distances between them not exceeding 2.1m when assembling and dismantling. The maximum number of people on a working platform level permitted to simultaneously exert a horizontal load of 30kg is:

- 1 person per bay for bays less than 4m long
- 2 persons per bay for bays greater than 4m in length
- Check that all components, tools and safety equipment are on site (refer to quantity schedule), undamaged and that they are functioning correctly, particularly the brace claw locking mechanism. Full inspection guidance can be found at **www.bossacesstowers.com**.
- Damaged or incorrect components should not be used.
- Component weights can be found in the quantity schedule and on the corresponding product datasheets.
- Check that the ground on which the tower structure is to be erected and moved is capable of supporting the tower and within the levelling limits of the tower system.
- Check overhead that the area into which the tower structure is to be built contains no obstructions, particularly electrical or radio radiation hazards.
- Never stand on an unguarded platform positioned above the first rung of a tower structure. If your risk assessment shows it necessary, you may also need to guardrail platforms at this level.
- Tower components should be lifted using a reliable lifting material (e.g. a strong rope), employing a reliable knot (e.g. clove hitch), to ensure safe fastening and always lift within the footprint of the tower structure.

Safety First

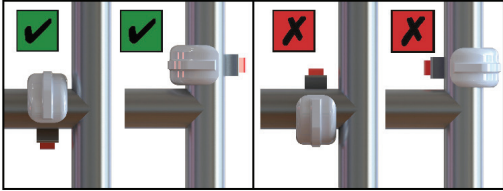

Ensure horizontal braces and guardrails are fitted correctly.

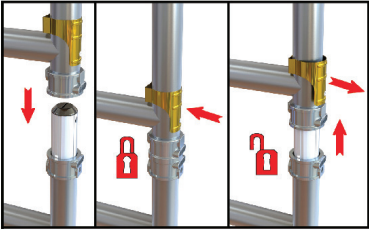

Ensure interlock clips on frame members are in the 'locked' position.

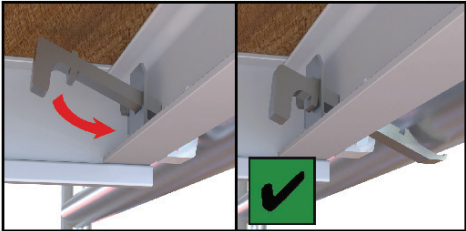

Ensure wind-locks are engaged before moving onto the deck levels.

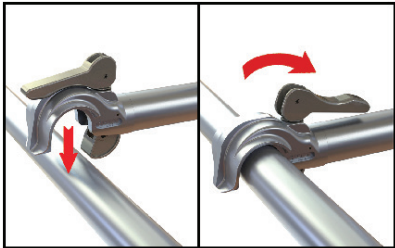

Ensure camlocks are engaged.

Component Diagram

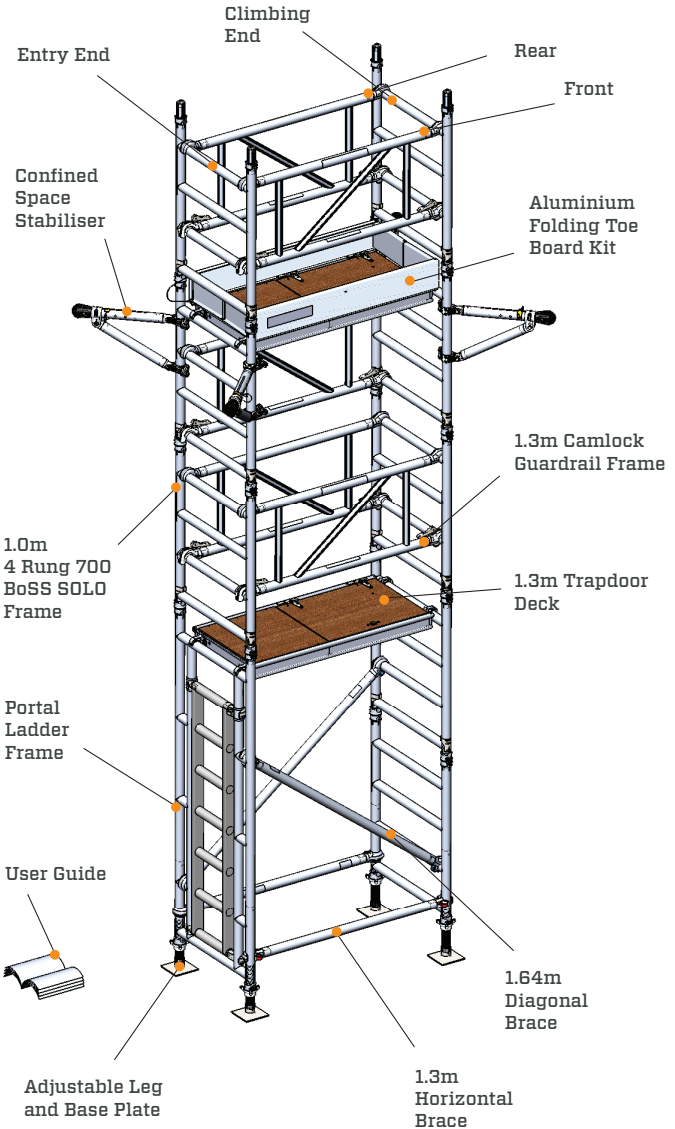

Quantity Schedule

BoSS LiftShaft⁷⁰⁰ : 1.3 x 0.7m (Camlock Guardrail)

Component code	Component description	Composite code	Internal use only																		
			67113022	67113042	67113062	67113082	67113102	67113122	67113142	67113162	67113182	67113202									
		Working height (m)	4.2	6.2	8.2	10.2	12.2	14.2	16.2	18.2	20.2										
		Platform height (m)	2.2	4.2	6.2	8.2	10.2	12.2	14.2	16.2	18.2	20.2									
33041300	Base Plate	1.7kg	4	4	4	4	4	4	4	4	4	4	4	4	4	4	4	4	4	4	4
33551300	Adjustable Leg	1.1kg	4	4	4	4	4	4	4	4	4	4	4	4	4	4	4	4	4	4	4
67011000	1.0m 4 Rung 700 BoSS SOLO Frame	3.9kg	4	8	12	16	20	24	28	32	36	40									
33052600	Mk 2 Portal Ladder Frame	12.8kg	1	1	1	1	1	1	1	1	1	1	1	1	1	1	1	1	1	1	1
35651300	1.3m Horizontal Brace	1.6kg	2	2	2	2	2	2	2	2	2	2	2	2	2	2	2	2	2	2	2
35751300	1.64m Diagonal Brace	1.9kg	2	2	2	2	2	2	2	2	2	2	2	2	2	2	2	2	2	2	2
67030100	1.3 Camlock Guardrail Frame	5.0kg	2	5	8	11	14	17	20	23	26	29									
67070100	1.3m Trapdoor Deck	9.8kg	1	2	3	4	5	6	7	8	9	10									
31651400	Confined Space Stabiliser	2.9kg	0	4	4	8	8	12	12	16	16	20									
67050100	Aluminium Folding Toe Board Kit	4.4kg	1	1	1	1	1	1	1	1	1	1	1	1	1	1	1	1	1	1	1
106792	User Guide	-	1	1	1	1	1	1	1	1	1	1	1	1	1	1	1	1	1	1	1
	Total Self Weight of Tower (kg)		71	123	163	215	256	308	348	400	440	492									
	Max. Extended Leg Load (kg)		143	156	166	179	189	202	212	225	235	248									
	Max. exerted prop load		-	16	16	16	16	16	16	16	16	16	16	16	16	16	16	16	16	16	16

(Working and Platform heights are measured from underside of lowest base plate.)

Build Aid:

For every 2.0m lift required, add an additional four 4 rung frames, one trapdoor deck and three camlock guardrail frames. Confined space stabilisers or props must be used at every 4.0m interval (see pages 8 - 9 for advice).

Platform heights above 2.2m

Platform heights above 2.2m can be achieved with the use of props. Please refer to page 7 for advice.

Build Method

When building a BoSS tower

To comply with 'Work at Height Regulations' we show assembly procedures with platforms every 2 metres in height and the locating of guardrails in advance of climbing onto a platform to increase safety and reduce the risk of a fall. Never stand on an unguarded platform positioned above the first rung of a tower. If your risk assessment shows it necessary, you may also need to guardrail platforms at this level.

The procedure illustrated shows a 6.0m working height tower.

BoSS recommend two persons are used to build BoSS Towers. Above 4.0m height, it is essential that at least two persons are used. Only climb the tower from the inside.

- 1** Connect the 4 rung frame together with the portal ladder frame. Ensure interlock clips are engaged. Insert base plates into adjustable legs and fit them into the frame subassembly. Insert two more base plates into adjustable legs and fit them into the 4 rung frame. Note the difference in gaps between the bottom of the leg and the adjustable nut.

Note: Adjustable legs are for levelling only. They are not to be used to gain extra height at the working level.

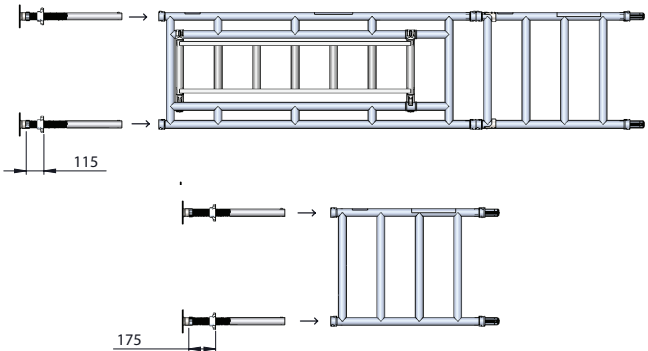
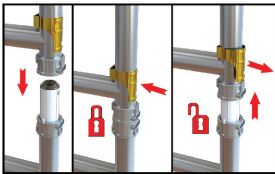

Build Method

2 Fit two horizontal braces (red catch) onto verticals of the 4 rung frame above the bottom rung as shown, with the claws facing outwards. These frames will form the climbing end of the tower and should be positioned at the far end of the LiftShaft⁷⁰⁰.

NOTE: All locking claws must be opened before fitting.

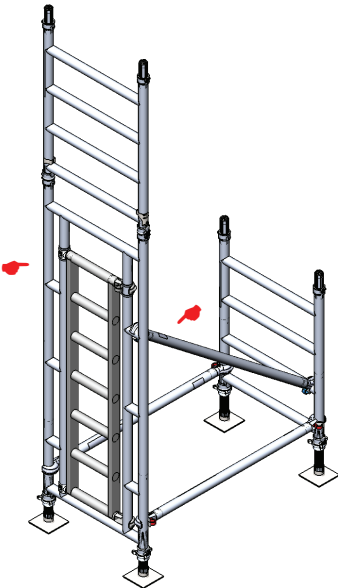
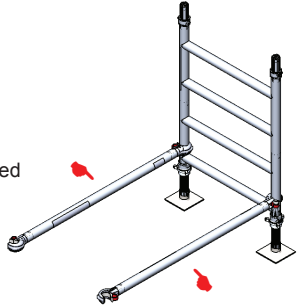
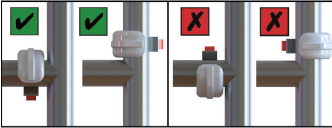

3 Position portal ladder frame sub-assembly at entry end of tower and fit other end of horizontal braces just above the bottom rung. The structure will now be self-supporting. Fit one diagonal brace (blue catch) from the bottom rung of the portal ladder frame to the fourth rung of the end frame on the front of the tower as shown. Claws must face downwards.

The structure must be vertical to within 1cm per metre. Ensure the frames are vertical and level by checking with a spirit level and setting the adjustable legs as required.

Build Method

4 Connect two more 4 rung frames and fit them onto the climbing end of the tower. Ensure interlock clips are engaged. Fit one more diagonal brace as shown.

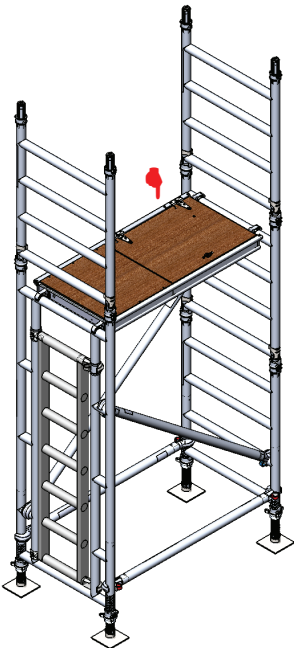
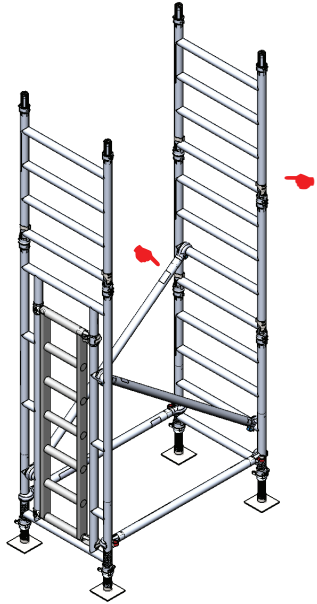

5 Fit one 1.3m trapdoor deck onto the top rung of the portal ladder frame as shown. Ensure the trapdoor opens towards the rear of the tower.

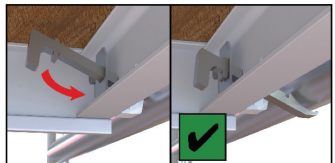

Ensure all wind-locks are engaged.

Build Method

6 From the protected position of the trapdoor deck (i.e. seated), fit a camlock guardrail frame on the rear of the tower, with the upper claws located on the 4th rungs above the platform deck.

Repeat with a second camlock guardrail frame on the front of the tower.

Engage camlocks to lock guardrail units in position.

Do not climb onto the deck until all guardrails are in place. Ensure the gate is fully engaged before climbing.

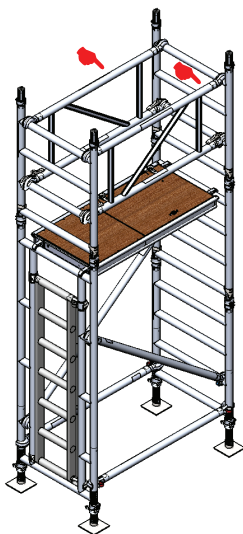
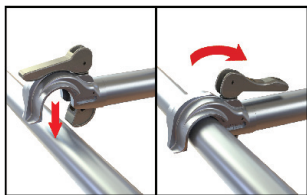

7 Connect two 4 rung frames together to create two sub-assemblies. Engage interlock clips. Whilst standing on the protected platform deck, fit one subassembly onto the entry end of the tower. Again, engage interlock clips. Repeat for the climbing end of the tower.

Fit a camlock guardrail frame to the rear of the tower, with the upper claws located on the 7th rung above the platform deck.

Engage camlocks to lock the guardrail unit in position.

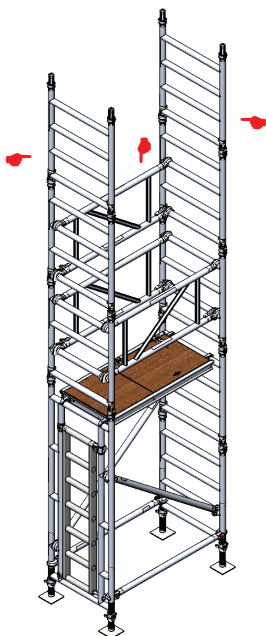

Build Method

8 Fit one 1.3m trapdoor deck onto the 8th rung above the platform deck as shown. Ensure wind-locks are engaged.

Fit a confined space stabiliser (or prop/tie) to all four corners of the tower as shown. See instructions below and on page 7.

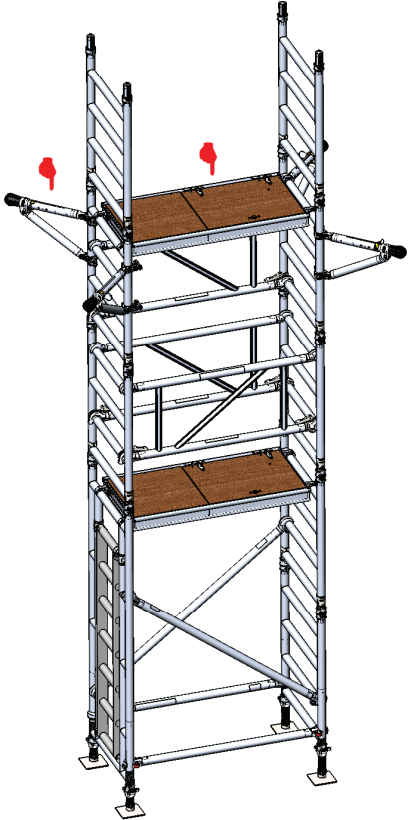

Ensure the end of the stabiliser arm contacts the wall. If it does not, adjust by unclipping and extracting the locking pin, sliding the arm until correct length and hole alignment is achieved. Reinsert the locking pin, ensuring clip is engaged. See images below.

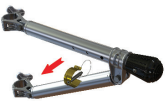

Unclip & extract pin



Extend/retract adjustable arm



Reinsert pin and engage clip

Build Method

9 From the protected position of the trapdoor deck (i.e. seated), fit a camlock guardrail frame on the rear of the tower, with the upper claws located on the fourth rungs above the platform deck. Repeat with a second camlock guardrail frame on the front of the tower. Engage camlocks to lock guardrail units in position.

Do not climb onto the deck until all guardrails are in place.

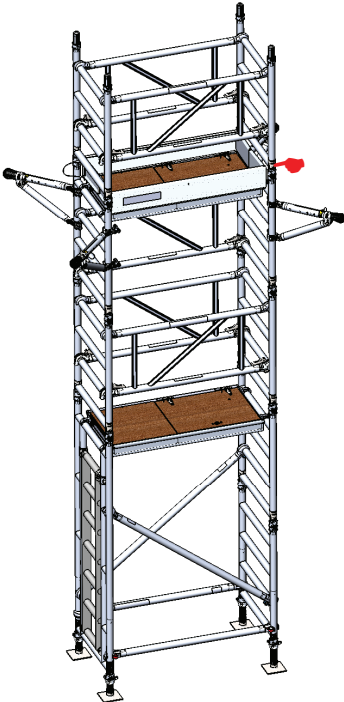
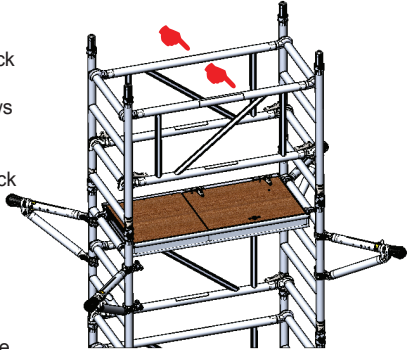

10 Unclip storage strap from aluminium folding toe board set, unfold and fit into position on working platform.

Ensure it sits squarely around deck and does not impede the opening of the trapdoor in the deck.

THE TOWER IS NOW COMPLETE.

Build Method

When building beyond 4.0m platform height

Continue to add two pairs of assembled 4 rung frames, three camlock guardrail frames, one trapdoor deck and four confined space stabilisers as shown in previous steps. At every platform level add guardrails between 2nd and 4th rungs above the platform. Confined space stabilisers (or props/ties) must be added at 4.0m intervals.

Fit these guardrail frames from the protected trap door position. Do not climb onto the platform until all guardrails are in place. Continue until the required height is reached.

When building 2.0m platform height only

Erect by following steps 1 - 6 & 10 only.

To dismantle a BoSS tower

Simply follow the assembly steps in reverse, ensuring that the 3T method is followed.

Pre-use Safety Inspection Checklist

Description	Yes
Tower structure upright and level	
Castors locked and legs correctly adjusted	
Diagonal braces fitted	
Stabilisers fitted as specified	
Platforms located and wind-locks engaged	
Interlock clips engaged	
Toe boards located	
Guardrails fitted correctly and positively locked	

For further information about this product or any other products and services, please contact:

The Causeway, Maldon,
Essex, CM9 4LJ,
United Kingdom

☎ +44 (0)1621 745900

🖨 +44 (0)1621 859845

✉ uk.customercare@wernerco.com

🌐 bossaccesstowers.com

Member of



PN108792

©2018 WernerCo Rev. 02/18