

TWO COMPARTMENT, PRESSURELESS, 200M BTU GAS FIRED STEAM GENERATOR, 24" WIDE CABINET BASE DESIGN, WITH NICKELGUARD™

Project _____
 Item _____
 Quantity _____
 FCSI Section 11400 _____
 Approved _____
 Date _____

Classic Series Convection Steamers, 15 PSI Boiler Base Style

Models

- 24-CGM-200



- Separate Main Power Switch for "On/Off"
- Exclusive Steam Cooking Distribution System: The exclusive Convection Jets produce a high velocity convection steam without fans. Coved Corner design in cooking compartment distributes heat evenly and is easy to keep clean. Creased top & bottom enhance drainage. Cold Water Condenser for each compartment maintains a dry steam. Fully insulated cooking compartment for thermal efficiency. Removable Stainless Steel Slide Racks for easy cleaning.
- Exclusive "Cool to the Touch" Compartment Door Design: Free floating inner door with reversible door gasket provides an air tight seal. Stainless Steel Slam/Latch Door Latch mechanism provides greater reliability.
- Left Hand Door Hinging: Compartment Doors hinged left, controls on the right.
- Modular Cabinet Base with Hinged Door.
- High Efficiency Gas Steam Generator with Nickelguard™, Electronic Spark Ignition and Automatic Water Fill on start up.
- Automatic Generator Drain at shutdown: Contains a "Water Jet" Spray Rinse Cleaning Cycle to keep drain clear.
- Automatic Generator Mineral Purging Cycle automatically cleans generator, reducing scale build up
- Automatic Water Level Control System with Low Water Power Cut-off Circuit.
- Steam generator equipped with High Limit Pressure Safety Switch, 15 psi Safety Valve, and Steam Generator Pressure Gauge.
- NSF Certified 6" Stainless Steel Legs with adjustable flanged feet for a one inch level adjustment.
- Gas Pressure Regulator and Control Valve.
- Standard Voltage for Control: 115 volts, 60 Hz, single phase.
- All Controls are serviceable from the front.
- Secondary Low Water Cut-Off, factory installed (CALG)
 (Required for AZ. AR. CA. CO. CT. DE. FL. GA. HI. IL. IA. KS. MD. MA. MI. MN. MT. NE. NV. NM. NC. OK. OR. PR. RI. TN. UT. VA. WA. WV., Buffalo, NY, Wash. DC)

Short Form Specifications

Shall be Two Compartments, CLEVELAND Convection Steamer, Model 24-CGM-200, Gas-fired Steam Generator, Nickelguard™, 200M BTU. Solid State Controls operate timing, water level and safety functions. Steam Generator with Automatic Water Fill on start-up, Automatic Blowdown with additional Manual Drain Valve and Electronic Spark Ignition. For each cooking compartment: 60 minute Mechanical Timer, Manual Operation Mode and Cold Water Condenser. Type 304 Stainless Steel cooking compartment.

Standard Features

- Cooking Capacity for up to six 12" x 20" x 2 1/2" deep Cafeteria Pans.
- Pressureless cooking with forced convection steam, permitting doors to be opened while cooking continues.
- Solid State Controls operate water level and safety functions.
- Each compartment is equipped with a 60 minute mechanical timer, separate bypass switch for constant steaming and a cold water condenser for superior cooking results.
- Instant Steam Standby Mode: Holds generator at steaming temperature. Allows unit to start cooking instantly.
- Durable 14 Gauge Stainless Steel Construction: For Compartment Door and Steam Cooking Cavity.

Options & Accessories

- Cafeteria pans in depths of 1", 2 1/2", 4" and 6"
- Power Take Off Kit (GPTO), Kettle Interconnecting Kit (IMK-)
- Correctional Packages
- Quick Disconnect for gas line (QDC)
- Boiler Descaling Pump Kit (107142)
- Water Filters

KE004046-26

ALLOW 6.00" MIN CLEARANCE FROM REAR AND SIDES IN NON-COMBUSTABLE LOCATIONS

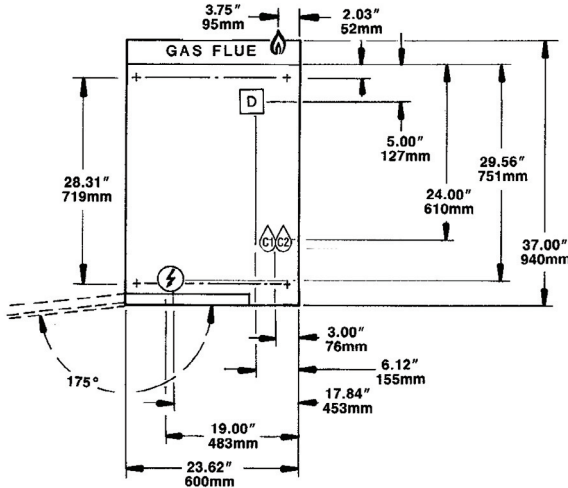

COMPARTMENT HAS CAPACITY FOR:

- Three, 12" x 20" x 2 1/2" deep Cafeteria Pans

WATER QUALITY REQUIREMENTS (Boilers, Generators)

TTDS:	50-250 ppm
Hardness:	50 - 200 mg (3 - 12 gpg)
pH value:	7.0 - 8.5
CL (Chloride):	max 50 ppm
Cl2 (free chlorine):	max 0.1 ppm
SiO2 (silica):	max 13 ppm
NH2Cl: (mono-chloramine)	max 0.1 ppm
Total Alkalinity:	50 - 100 ppm
Water Pressure	35 - 80 PSI
Temperature:	max 104°F

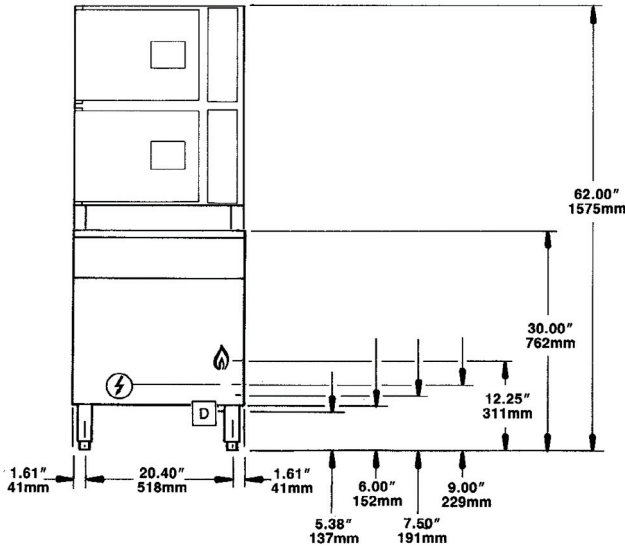

SHIPPING WEIGHTS & DIMENSIONS

Weight	Width	Depth	Height
617 lbs	30"	43"	78"

NOTE: When ordering optional reverse door openings: Control Panel, door openings, cooking compartments and clearances are opposite that shown.

GAS		ELECTRIC	WATER	DRAINAGE	CLEARANCE
NATURAL	PROPANE	115V - 1 PH 25 watts per compartment. 50 watts for Steam Generator Control. 5.0 Amps ** Do not connect to GFI outlet. See note below.	1/4" NPT Cold Water Inlet 35 psi minimum 60 psi maximum Condenser feed Boiler feed	The Floor Drain must be located outside the confines of the equipment base. 1 1/2" NPT common drain. Do not connect other units to this drain. Do not use PVC pipe for drain.	Right - 6", Left - 6", Rear - 6" (12" on control side if adjoining wall or equipment is over 30" high for service access) For use in non-combustible locations. Contact factory for variances to clearances.
3/4" IPS for 220,000 BTU or less. 1.00" IPS for 250,000 BTU or more. Supply pressure: 4.00" W.C. minimum 14.00" W.C. maximum	3/4" IPS for 220,000 BTU or less. 1.00" IPS for 250,000 BTU or more. Supply pressure: 12.00" W.C. minimum 14.00" W.C. maximum				
Manufacturer must be notified if unit will be used above 2,000 ft. altitude.					

NOTES:

**DO NOT CONNECT TO GFI OUTLET. CLEVELAND RANGE RECOMMENDS GAS FIRED 120 VOLT STEAMERS BE HARD WIRED DIRECTLY TO ELECTRICAL SYSTEM.

Cleveland Range reserves right of design improvement or modification, as warranted.

Many regional, state and local codes exist and it is the responsibility of the owner and installer to comply with the codes.

Cleveland Range equipment is built to comply with applicable standards for manufacturers. Included among those approval agencies are ASME/N. Bd, UL, NSF and CSA (AGA, CGA).

(NOT TO SCALE)