

#### PERFORMANCE

Designed for fast delivery and excellence even in large volumes, the **Forza STi** is ideal for QSR - Quick service restaurants (fast-service restaurants), as well as pizzerias, bakeries, hotels, snack bars and convenience stores.

The productions of pizzas, empanadas, calzones, cookies and others, become even better with the Forza STi, which guarantees appearance, taste and superior textures, developed with cutting-edge technologies such as impinged air and infrared, achieves preparations up to 50% faster than in conventional ovens.

#### FEATURES

- Capacity for pizzas up to 16 inches;
- Touch screen controls with the most friendly and easy interface on the market;
- Up to 1024 recipes – 8 steps each recipe;
- USB port to upload/download recipes;
- Easy to clean;
- Temperature adjustable from 86°F (30°C) to 626°F (330°C);
- Cool temperature exterior surfaces;
- Certified Ventless with easy removable catalytic converter;
- Variable-speed impingement airflow;
- Independently controlled top and bottom heaters;
- Double glass door with easy clean system;
- Allows the use of metal pans;
- Constructed from AISI430 (exterior) and AISI304 (interior) stainless steel;
- Manual mode for on-the-fly cooking;
- Warranty – 1 year parts and labor;

#### STANDARD ACCESSORIES

- 01 - Aluminum Mesh Screen;
- 01 - Aluminum Paddle;
- 01 - Door Cleaning Tool;
- 01 - USB Drive;
- 04 – Adjustable Feet;



#### MODULATIONS

Stand-alone | Stackable

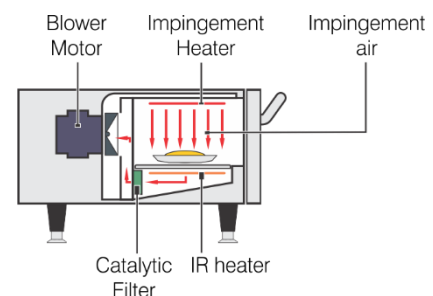

**PRODUCT DIMENSIONS**

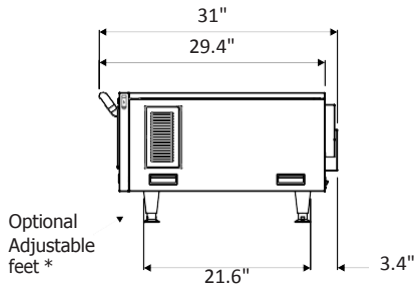

SIDE VIEW

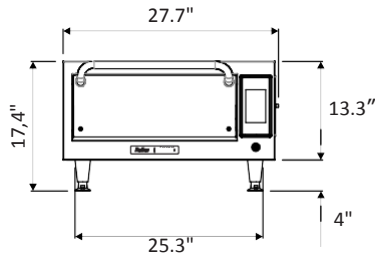

FRONT VIEW

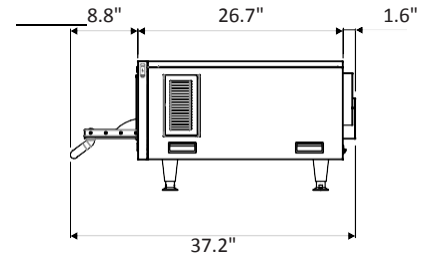

SIDE VIEW WITH OPEN DOOR

**DIMENSIONS**

Forza STi	Product Dimensions				Boxed Product Dimensions				Chamber Dimensions	Capacity	Height	Width	Depth
	Height	Width	Depth (w/handle)	Weight	Height	Width	Depth (w/handle)	Weight		0.65 cu.ft	3.6"	18.1"	17.1"
Without feet	13.3"	27.7"	31"	148 lbs	22.8"	31.9"	35"	209.4 lbs	Wall Clearance	Left Side	Back	Right Side	
With feet	17.4"	27.7"	31"	148 lbs	22.8"	31.9"	35"	209.4 lbs		0"	0"	1"	

**INSTALLATION**

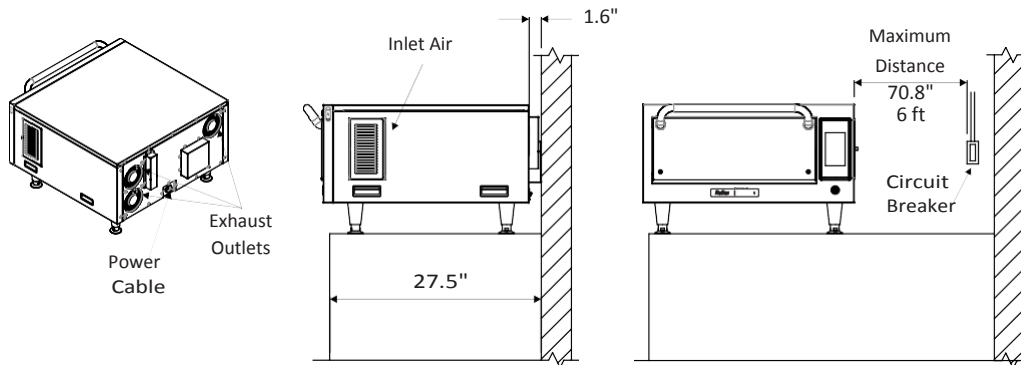

**STACKED VERSION DIMENSIONS**

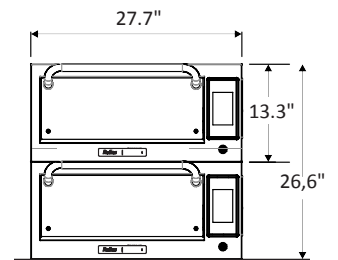

ITEM	DESCRIPTION	QTY.
1	PADDLE BASE	1
2	GAUNTLET	1
3	400 MM CABLE	1
4	HAND PROTECTOR	1
5	FLAT HEAD SCREW M5 X 15 MM	2
6	ALLEN WRENCH	1

**PADDLE ASSEMBLY**

USE THE ALLEN WRENCH THAT COMES WITH THE PADDLE.

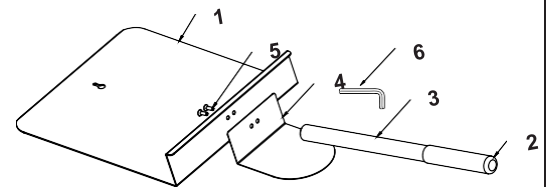

March 2021- Revision: 04

**ELECTRICAL SPECIFICATIONS**

Ensure that the electrical characteristics of the building network are in accordance with the technical specifications located on the data badge located on rear panel of the unit. The outlet should be located no more than 70.8in / 6 ft / 1.8 m away from the unit.

This unit must be properly grounded to avoid electrical shock. This unit is equipped with a 3-prong plug. This plug must be connected to a properly installed and grounded outlet. In the event of an electrical short, properly grounding the unit reduces the risk of electrical shock by grounding the electrical current.

The building electrical is the customer's responsibility.

Region	Voltage (V)	Phases	Freq. (Hz)	Power (kW)	Circuit Breaker (A)	Cable	Socket
Canada	208	Single	60	5.6	30	3x10 AWG	NEMA 6-30
USA	240	Single	60	7.2	30		

**GENERAL INSTRUCTIONS**

The oven must be installed on a base or counter that supports the weight of each unit (approximately 148lbs stand-alone or 296lb/stackable).

For proper ventilation, a minimum space of 1" between the right side of the oven and the wall is required.

Do not block the air inlets and exhaust outlets located on the back and right side of the oven.

It is not recommended for the unit to be positioned near stoves, deep fryers, hotplates and other equipment that releases fat, fumes and heat.

The oven must be installed at a leveled and ventilated location. Improper installation may void the equipment warranty.