



TITAN 1000 REAR SEAT

(will fit Yamaha® Drive®)

ITEMS INCLUDED

- Hardware packs 1-7
- Grab Bar
- Bagwell Bracket
- Lean Back Brackets
- Armrests
- Footrest
- Main Frame
- Bagwell Hold Downs

TOOLS NEEDED

- Drill
- 17mm Socket
- 17mm Wrench
- 14mm Socket
- 10mm Socket
- #3 Phillips Bit
- 3/8" Drill Bit
- 13mm wrench

NOT REQUIRED when using seat cushions supplied with this seat kit



Use this bracket only when installing custom cushions such as TSUNAMI, or similar



Bagwell Bracket



Armrests



Footrest



Main Frame



Grab Bar



Main Bracket



Bagwell Hold Downs

WARNING:

We recommend professional installation. If you choose not to have this product installed by a professional, we highly recommend that you exercise caution, care, and patience when installing this product as it involves drilling holes into your cart's body.

STEP 1

Remove hardware from struts and take off canopy. Retain hardware.

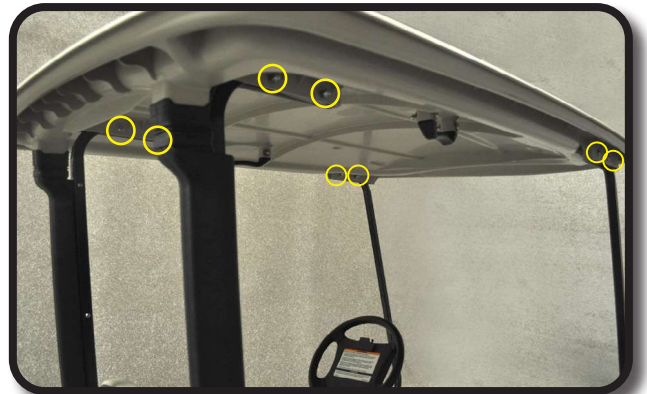

STEP 2

Remove hardware from gutters. Remove gutters by sliding them upward. Retain hardware and gutters.



STEP 3

Remove rear struts from both sides.



STEP 4

Remove seat back. Retain hardware.

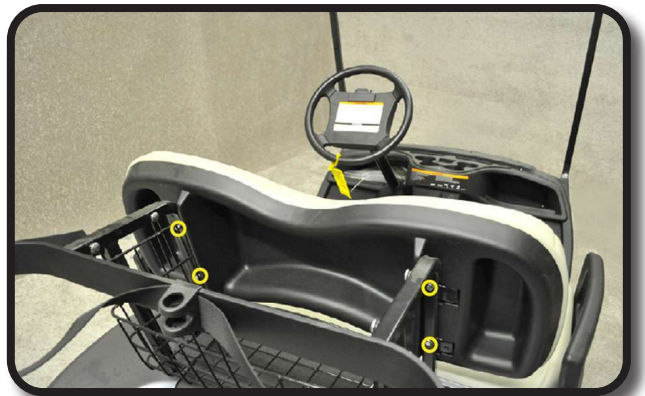

STEP 5

Remove motor cover panel by popping out plastic rivets. Retain hardware.



STEP 6

Take off basket by removing hardware located inside motor compartment. Retain hardware.

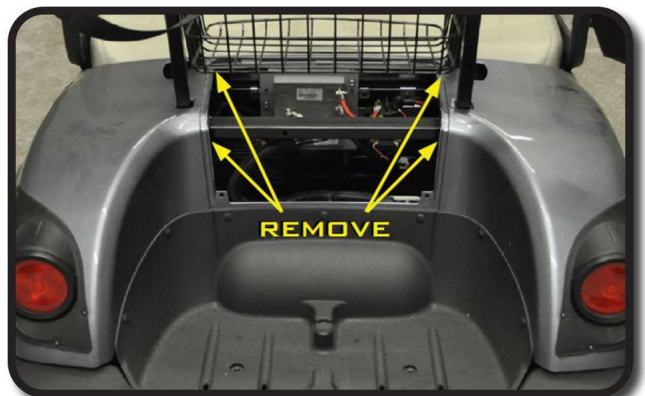

STEP 7

Place seat back brackets into body frame as shown, using retained hardware from Step 6. Tighten bolts and repeat process on the other side.

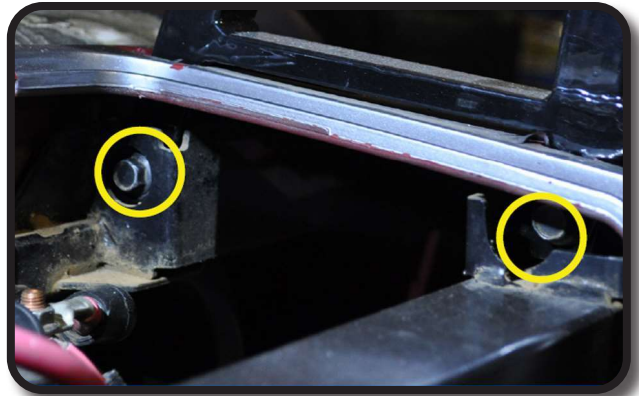

STEP 8

Attach factory struts to main bracket's using retained hardware from step 3.



STEP 9

Attach factory strut to plastic gutter using hardware retained from Step 2.

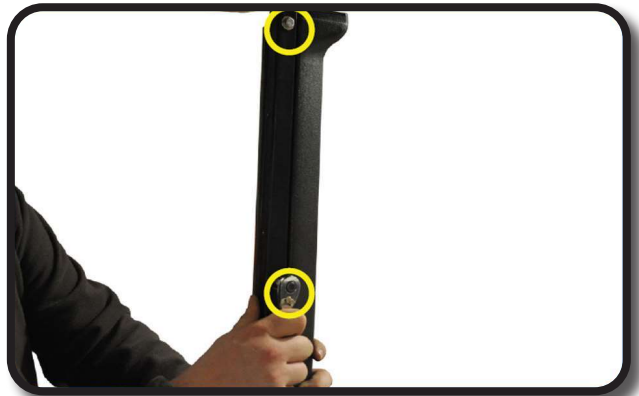

STEP 10

Using hardware retained from Step 4, attach seat back cushion to seat bracket as shown.



STEP 11

Attach bagwell hold downs to bagwell bracket as shown using 8x25mm countersunk hardware in Pack 1. Cover nuts with caps supplied in pack.



STEP 12

Remove factory bolts from bagwell. Enlarge hole by drilling using a 3/8" drill bit.

IMPORTANT: Be sure to drill all the way through the frame.



STEP 13

Attach bagwell bracket to cart using 10mm x 90mm hardware from Pack 1 and tighten.



STEP 14

Attach main polyboard frame using 8 x 70mm hardware from pack 2.

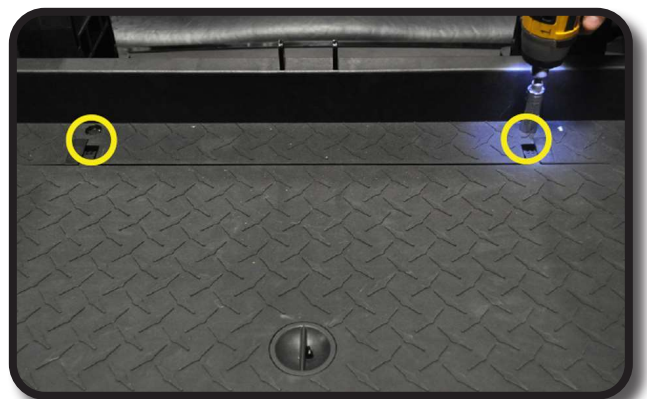

STEP 15

Attach main polyboard frame to bagwell brackets using 10 x 50mm hardware from Pack 2. DO NOT TIGHTEN.



STEP 16

- A. Using 3/8" drill bit, gently drill through back bumper as shown.
- B. Using a #3 Phillips bit, attach bagwell bracket to cart using 10x100mm countersunk hardware from Pack 2.



STEP 17

Attach bagwell bracket to cart using 10mm x 90mm hardware from Pack 1 and tighten.



STEP 18

If using cushions supplied with this seat kit - Skip this step. Do not install brackets shown in picture.

If installing any custom seat cushions, attach the brackets shown here. Using the appropriate labeled hole for your cart, attach this bracket to main seat bracket using hardware from Pack 5.

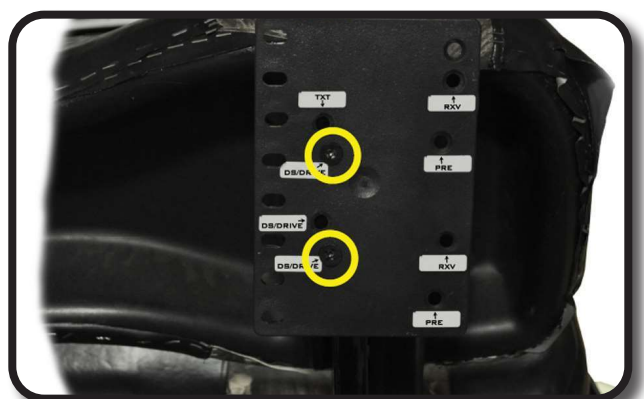

STEP 19

Bolt front back rest to main brackets.

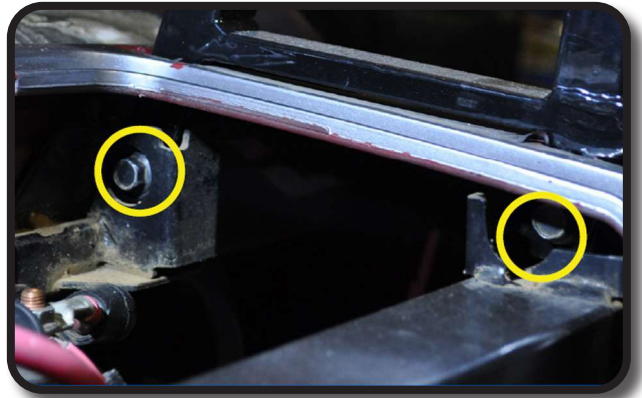

STEP 20

Attach footrest bracket as shown using hardware from Pack 6.

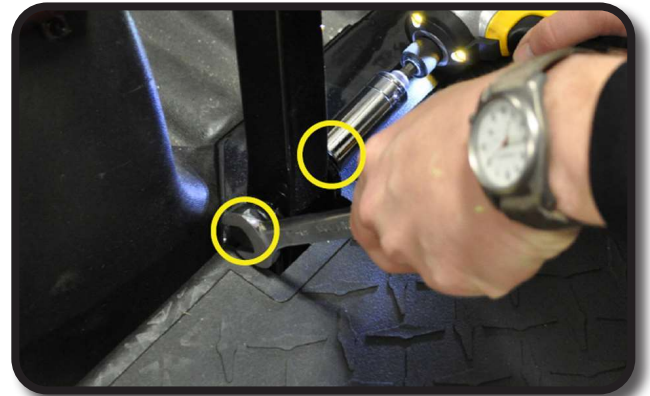

STEP 21

Attach grab bar to foot rest using hardware from Pack 6.

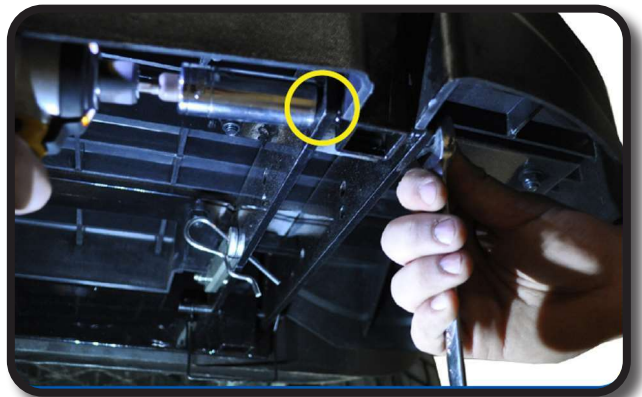

STEP 22

Using quick release pins from hardware Pack 6 secure footrest to bagwell bracket.



STEP 23

Attach seat bottom cushion as shown using hardware from Pack 7.



STEP 24

Footplate can be folded up by removing the four c-clips and folding forward. To lock footplate in up right position use brackets as shown.

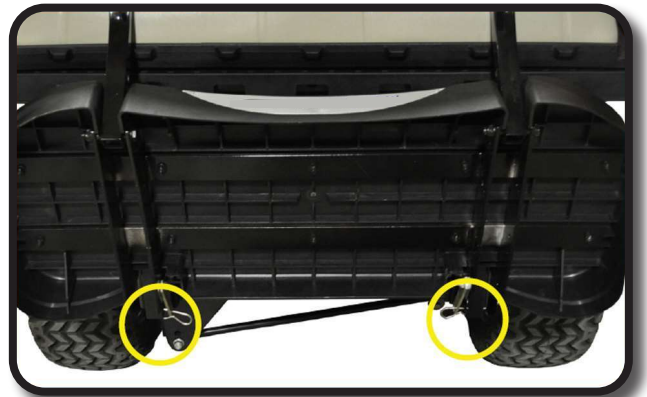

INSTALLATION COMPLETE

Yamaha, G-14™, G-19™, G-22™, G29™, Drive, and Drive² are registered trademarks of Yamaha Golf-Car Company and Yamaha Motor Corporation ("Yamaha"). Reference to Yamaha's trademarks and products is only for the purposes of identifying golf carts with which this product is compatible. These products are aftermarket parts and not original equipment parts. Excalibur is not connected or affiliated or sponsored by Yamaha Motor Corporation or Yamaha Golf Car Company.

HARDWARE PACK

Pack 1

- 4 – 8x25mm countersunk #3 phillips
- 4 – 8x18mm flat washer
- 4 – 8mm lock nut
- 2 – 10x90mm hex bolt
- 4 – 10x20mm flat washer
- 2 – 10mm lock nut
- 4 – 6mm nut caps
- 4 – Rubber washers

Pack 2

- 2 – 8x70mm hex bolt
- 4 – 8x15mm flat washer
- 2 – 8mm lock nut
- 4 – 10x50mm Hex bolts
- 4 – 10x20mm flat washer
- 2 – 10mm lock nuts
- 10 – Rubber Washers
- 2 – 10x100mm countersunk #3 Phillips
- 2 – 10x20mm flat washer
- 2 – 10mm lock nuts

Pack 3

- 4 – 8x35mm hex bolt
- 4 – 8x15mm flat washer

Pack 4

- 4 – 8x30mm countersunk #3 Phillips
- 4 – 8x15mm flat washer
- 4 – 8mm locknut

Pack 5

- 4 – 6x25mm hex bolt
- 4 – 6x15mm flat washer
- 4 – 6mm lock washer

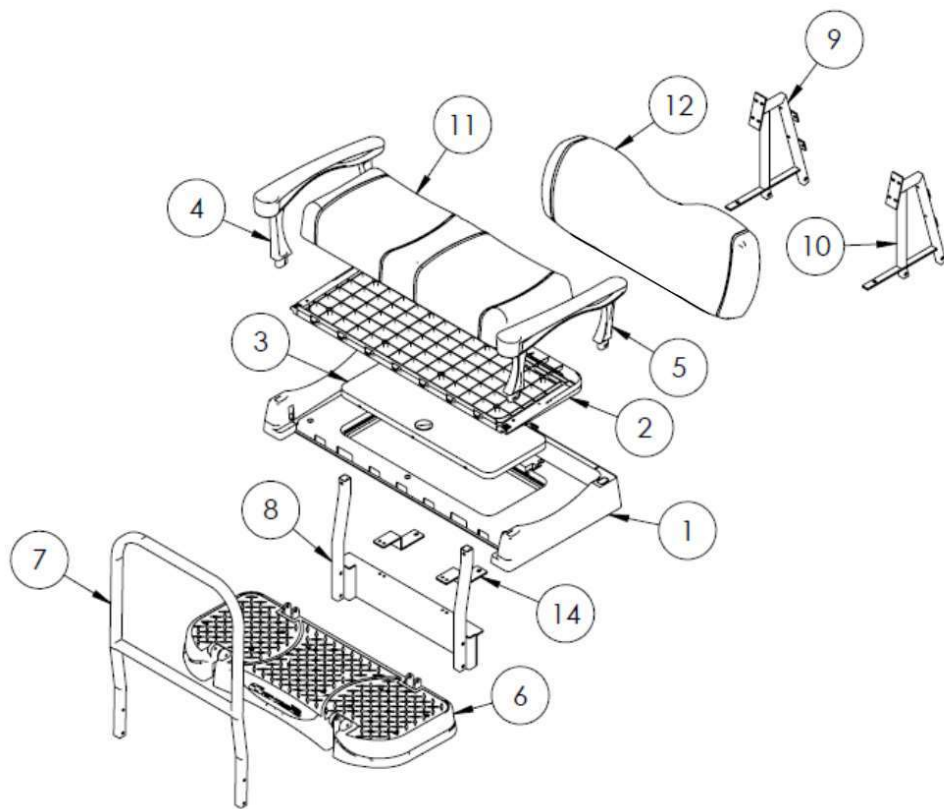

Pack 6

- 4 – 10x75mm hex bolt
- 8 – 10x20mm flat washer
- 4 – 10mm Locknut
- 8 – Rubber washers
- 4 – Quick release pins (easy remove hardware for folding in the foot plate)

Pack 7

- 8 – 8x40mm countersunk