

QUANTUM 400/400H/400P Intersegmental Table Service & Instruction Manual



**NEW
Remote System**



**Exclusive
Glide-Trak
System**



Armedica Manufacturing Corporation
212 Bell Road P.O. Box 880
Greenwood, AR 72936-0880
(800) 701-5122 www.ArmedicaMfg.com



QMS
ISO 13485
FM 50089

Table of Contents

Indications	3
Contraindications	3
Precautions	3
Positioning Patient on Table	3
Operation of Controls	4
Table Options	5
Treatment Considerations	5
Cleaning and Maintenance	5
Warranty Information	6
Parts List	7
Patient Assist Bar Assembly	9
Schematics / Parts Breakdown:		
Cabinet Base	10
Table Top	11
Roller Carriage	12
Turn Around Assembly	13
Wiring Diagram	14

Indications –

The Quantum 400/400H/400P is an electromechanical treatment table. It is designed to release muscle tension and deliver soothing massage.

Contraindications –

1. Phlebitis
2. Fractures or suspected fractures
3. Common skin problems such as:
sunburn, bruises, boils or shingles may be irritated by the rollers
4. Patients with fused discs or implanted scoliosis rods
5. Osteoporosis

Precautions –

- ✓ **Use with caution on elderly patients**
- ✓ **Use with caution on patients with acute pain**
- ✓ **Not intended for use on patients weighing over 300 pounds**

Positioning Patient on Table –

1. Make sure the rollers are in the down position.
2. Have the patient remove any keys, wallets or other items from back pockets that may cause discomfort when rollers are in motion.
3. Assist patient onto the table with head at the roller end (above the Cervical –Thoracic – Lumbar position indicator) and feet over the foot cover apron.
4. Position patient on the table so that the sacrum is located at the end of the roller slot. Make sure the patient is centered on the table to allow the roller to track on both sides of the spine. Place the knee pillow under the patient's knees.

Operation of Controls



Power – Turns the main power to the table on or off.



Vibration – Turns the vibration mode on or off.



Heat – (Option available on Model 400H)
(See page 5)



Direction – Determines the counter-clockwise or clockwise direction of the roller when in motion. Standard position is counter-clockwise rotation.



Lock – Prevents patients from changing the table settings. To unlock, hold in button for three seconds.



Treatment Time Indicator



Start/Stop – Push once to start selected therapy. Give to the patient to use as a remote stop.



Travel – Controls the tracking of the rollers from Cervical to Lumbar. The ON position is when the button is lighted, which allows the rollers to track the full range. The OFF position is when the button is not lighted, halts the horizontal movement of the rollers, and allows treatment to take place in a selected area.



Timer/ Roller Height Control – Timer may be set from 1 to 30 minutes by using the arrow buttons. Toggle up or down to set the height of the rollers



when the timer is active. Rollers will retract to lowest position when time expires.

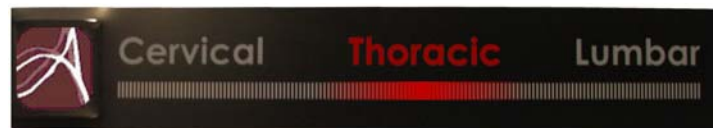

Roller location indicator panel –

Red light behind Cervical – Thoracic – Lumbar panel indicates horizontal position of rollers.



NOTE:

Remote control automatically defaults to last settings used

Table Options for Quantum 400 –

Heat – (Option available on Model 400H) If the heat button is lighted, this indicates the heat is in the ON position. If the heat button light is not lighted, this indicates the heat is in the OFF position.

Patient Assist Bar – (Option available on Model 400P) Patient assist bar allows for greater ease of patient dismounting.

Facial Slot – (Option #401) Face slot under foot cover apron allows for use as a therapy or adjustment table.

Treatment Considerations –

1. Always assist the patient on and off the table. The optional patient assist bar is advised, however it is recommended that an operator assist the patient.
2. Roller height should be set to a comfortable level. At no time should the patient experience pain or discomfort during the treatment. Continue to monitor the patient during the treatment.
3. The optional heat control should be used with caution, especially on patients with reduced sensory perception. Monitor the patient continuously during the treatment if heat is used.
4. It is recommended that lights above the table be turned down or off to prevent glare and discomfort to the patient during treatment.
5. Always evaluate the patient before and after the treatment.

Cleaning and Maintenance –

CLEANING – The use of a mild soap and water solution or an approved vinyl cleaner is recommended to keep the table looking presentable. When using a soap solution, be sure to remove any residue after cleaning. Do not use any agent that will dry out the vinyl such as alcohol, window cleaning solutions, strong detergents or abrasive materials. Face paper squares are recommended in the cervical area to cover the cervical pillow and vinyl and prevent skin oils from contacting the vinyl.

MAINTENANCE – The Quantum 400/400H/400P requires very little routine maintenance. All tables are extensively tested at the factory prior to shipping, however, occasionally rough treatment by trucking companies may require minor adjustments after delivery. In the event unusual noises are heard or proper operation is compromised, call the Armedica Service Department for assistance.

It is recommended that at six-month intervals, the top is removed and the following items are checked: *(NOTE! Use caution when operating table with top removed. Do not place hands inside the table compartment while the table is operating. Be certain that you have no loose clothing or neckties that may be caught in the chains or moving parts.)*

1. Check to insure that the three black rollers are free to rotate without binding.
2. Check to insure that the chains are taut.
3. Check to insure that all wiring, including the power cord to the wall outlet, is stowed away from moving parts.

This equipment has been tested and found to comply with the limits for medical devices to the IEC 60601-1-2: Third edition 2007-03. These limits are designed to provide reasonable protection against harmful interference in a typical medical installation. This equipment generates, uses and can radiate radio frequency energy and, if not installed and used in accordance with the instructions, may cause harmful interference to other devices in the vicinity. However, there is no guarantee that interference will not occur in a particular installation. If this equipment does cause harmful interference to other devices, which can be determined by turning the equipment off and on, the user is encouraged to try to correct the interference by one or more of the following measures:

- Reorient or relocate the receiving device.
- Increase the separation between the equipment.
- Connect the equipment into an outlet on a circuit different from that to which the other device(s) are connected.
- Consult the manufacturer or field service technician for assistance.

Warranty Information

Limited Warranty –

Armedica Manufacturing Corporation warrants the Quantum 400/400H/400P Intersegmental table is free from defects in material and workmanship. This warranty shall remain in effect from the date of original shipment of the product under normal and proper use as follows:

1. Roller travel motor, roller rotation motor and roller elevation motor for a period of 5 years after purchase. Warranty includes motor replacement or repair. Labor for installation of new or repaired motor is covered for 1 year. In the event **non - Armedica Manufacturing Corporation** technicians perform labor; cost of such labor must be approved by **Armedica Manufacturing Corporation**.
2. The three black plastic rollers are warranted for the life of the table.
3. All other parts, excluding vinyl are warranted for a period of 1 year after purchase. Warranty includes replacement or repair of parts and labor. In the event **non - Armedica Manufacturing Corporation** technicians perform labor; cost of such labor must be approved by **Armedica Manufacturing Corporation**.

The purchaser agrees to pay for all labor and /or parts not covered under this warranty and to also pay for any expenses incurred during such repair.

Representations and/or warranties made by any person, including dealers, previous owners or any person not an employed representative of **Armedica Manufacturing Corporation** which are inconsistent or in conflict with the terms of this warranty shall not be binding on **Armedica Manufacturing Corporation**.

The use of this product is the responsibility of the prescribing health care provider. The diagnosis of the patient's condition, the choice of the use of this product and the method of use is the responsibility of the practitioner and not **Armedica Manufacturing Corporation**.

Armedica Manufacturing Corporation is an ISO 13485 registered facility.

PARTS LIST BY: ITEM NO

ITEM NO.	PART NO.	DESCRIPTION	QUANTITY
1	18613	CABINET BASE	1
2	02539	SCREW HEX HEAD #12x1-1/4	16
3	01118	ALUMINUM TRIM	1
4	03148	INDICATOR PANEL CERVICAL LUMBAR	1
5	03111	CASTER HOODED 1-7/8" BALL SWIVEL	4
6	02532	SCREW HEX WASHER HEAD #6x1	5
7	03034	TRACK CARRIAGE GUIDE 14GA	2
8	03280	CIRCUIT BOARD	1
9	03264	POWER CORD	1
10	12466	RECEPTACLE PLATE	1
11	03268	COILED CORD	1
12	03281	HAND HELD REMOTE CONTROL	1
13	19680	TABLE TOP	1
14	14121	VINYL FOOT COVER	1
15	19682	TABLE TOP WITH FACE HOLE OPTION	1
16	19685	TABLE TOP WITH HEAT OPTION	1
17	13040	ROD THREADED 1/2-13x14 CHAIN TENSIONER	2
18	02138	NUT HEX FIN 3/8-16	1
19	02045	SCREW HEX HEAD CAP 1/4-20x1	8
20	02522	BOLT CARRIAGE 1/4-20x1-1/2	4
21	02140	WASHER 1/4	29
22	02100	NUT NYLOCK 1/4-20	18
23	03120	MOTOR INTERSEG TRAVERSE DRIVE W/KEY	1
24	03260	SPROCKET ROLLER 1/2 ID 40BS10 W/ SET SCREWS	1
25	19677	CHAIN ASSEMBLY ROLLER CARRIAGE	1
26	19678	CHAIN ASSEMBLY TURN AROUND	1
27	12458	BRACKET FORMED 4-3/4x5x12 TENSION	1
28	02524	SCREW SOC HEAD CAP 1/4-20x1-1/4	1
29	02105	NUT NYLOCK 5/16-18	11
30	03256	BEARING 5/8 PILLOW BLOCK	2
31	12459	SHAFT 5/8x6 TURN AROUND SPROCKET	1
32	02545	WASHER LOCK SPLIT 1/2 ZINC	2
33	02062	SCREW HEX HEAD CAP 5/16-18x1-1/2	2
34	02110	NUT NYLOCK 3/8-16	2
35	18621	ROLLER SPROCKET ASSEMBLY	1
36	02150	WASHER 5/16	26
37	03150	STRAP CLAMP VIBRATOR MOTOR 2C703	1
38	03124	MOTOR VIBRATOR 3M564	1
39	03257	BEARING 3/4 PILLOW BLOCK	2
40	12463	BLOCK UHMW 1x1-1/2x2 TOP FRAME PIVOT	2
41	12456	BLOCK UHMW 3/4x1x2 POSITION LED	1
42	02130	NUT HEX FIN 5/16-18	3
43	18610	TOP FRAME ROLLER CARRIAGE	1
44	02181	SCREW HEX HEAD CAP 5/16-18x2-1/2	4
45	03121	MOTOR ROLLER ROTATION W/ KEY	1
46	03259	SPROCKET ROLLER 5/8 ID 40BS10 W/ SET SCREWS	2
47	18620	BAR TURN AROUND	1
48	02160	WASHER NYLON 5/16 ID	8
49	02114	SCREW HEX HEAD CAP 1/4-20x3/4	4
50	13039	ROD THREADED 5/16-18x9-1/2 INDICATOR LED	1

51	18608	BASE FRAME ROLLER CARRIAGE	1
<u>PARTS LIST BY: ITEM NO</u>			
<u>ITEM NO.</u>	<u>PART NO.</u>	<u>DESCRIPTION</u>	<u>QUANTITY</u>
52	02513	SCREW HEX HEAD CAP 3/8-16x1-3/4	1
53	12448	BAR 1/8x1 POTENTIOMETER LINK 13" LONG	1
54	12452	BAR ALUM 1/2x1/2x4-5/8 ELEVATION MOTOR	1
55	02514	SCREW HEX HEAD CAP 3/8x16x5-1/2	1
56	02519	COLLAR SET 3/8IDx3/4ODx3/8	1
57	03122	ROLLER ELEVATION MOTOR	1
58	02044	SCREW HEX HEAD CAP 1/4-20x1-1/4	4
59	19689	POTENTIOMETER WITH WIRE	1
60	02527	SCREW PAN HEAD PHIL SHEET METAL 6x1/2	6
61	02008	SCREW PAN HEAD 4-40x1/2	2
62	02038	SCREW FLAT HEAD SOC 5-40x1/2	2
63	02112	NUT NYLOCK 4-40	2
64	02531	NUT NYLOCK 5-40	2
65	03270	CONNECTOR RJ45	1
66	19690	RECEPTACLE WITH WIRE	1
67	03089	BEARING FLANGE BRONZE 1/4IDx3/8ODx3/8	1
68	02518	WASHER 3/8 NYLON FLAT	5
69	12462	BLOCK UHMW 3/4x1x1-1/4 GLIDE	4
70	02053	SCREW HEX HEAD CAP 1/4-20x1-1/2	1
71	03263	TERMINAL BLOCK 12 POLE 18-20GA 350V	1
72	02142	WASHER FLAT #6	5
73	02515	SCREW PAN HEAD PHIL #6-32x1	4
74	02077	NUT NYLOCK #6-32	4
75	02235	CABLE TIE 1/16" X 6"	26
76	02516	NUT HEX FIN #6-32	2
77	03249	TERMINAL BLOCK 4 POLE	1
78	19688	LED SIDE INDICATOR ASSEMBLY	1
79	02200	CLAMP CABLE 3/16 BLACK	1
80	02208	CLAMP CABLE 3/8 WHITE	3
81	02201	CLAMP CABLE 1/4 WHITE	2
82	02090	NUT NYLOCK 1/2-13	2
83	02145	WASHER 1/2	2
84	02501	SCREW PAN HEAD PHIL 10-32x1/2	4
85	02525	SCREW PAN HEAD PHIL SHT MTL 6x5/8 ZINC	10
86	02526	SCREW PAN HEAD PHIL SHT MTL 8x3/4 ZINC	12
87	02467	FUSE 10AMP 125V GMA	1
88	03269	1' PATCH CABLE	1
89	02135	NUT HX FIN JAM 1/2-13	4
90		CAPACITOR 12mF	1
91		CAPACITOR 4.0mF	1
92		SET SCREW 10-24x3/16	6
93		KEY .125x.125x.6875	1
94		KEY .187x.187x.875	1
95	Q400BV	QUANTUM BASE VINYL SEWN (SLEEVE) (OPTIONAL REPLACEMENT)	1
96	Q400TV	QUANTUM TOP VINYL SEWN (OPTIONAL REPLACEMENT)	1
97	18622	PATIENT ASSIST BAR	1
98	12483	PATIENT ASSIST BAR BACK PLATE	1
99	02523	WASHER LOCK SPLIT 3/8 ZINC	4

PATIENT ASSIST BAR ASSEMBLY INSTRUCTIONS

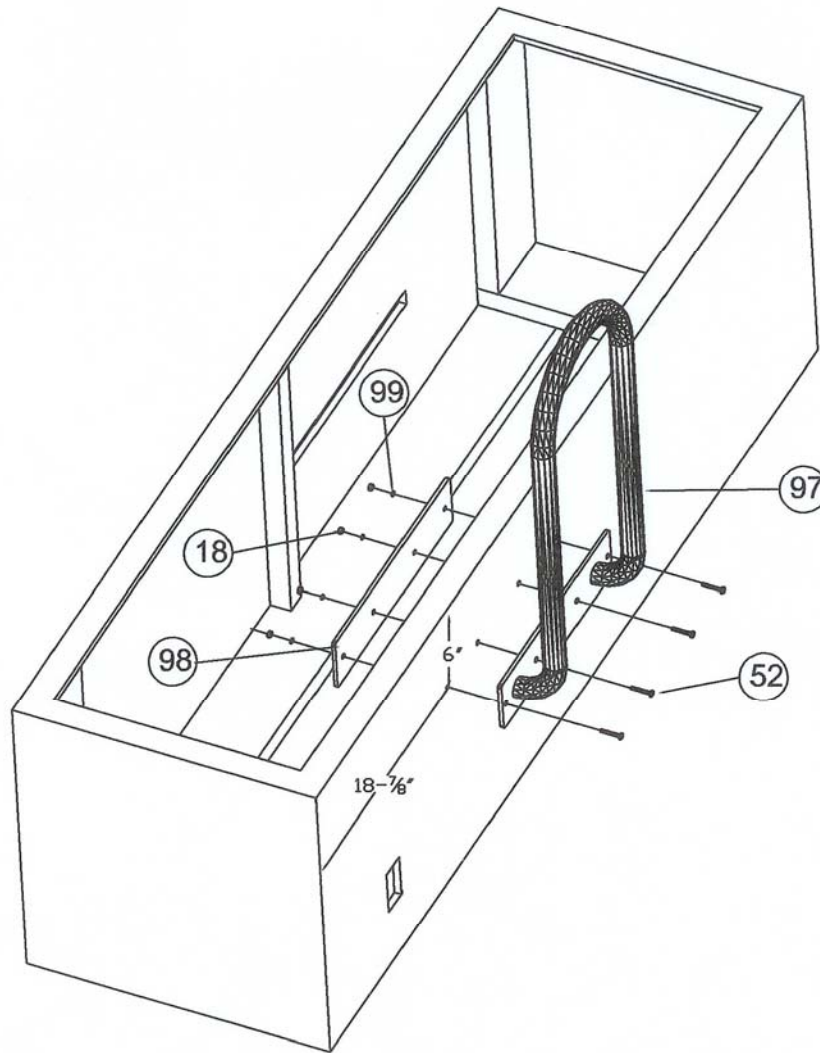

ITEM NO.	PART NO.	DESCRIPTION	QTY
97	18622	RAIL PATIENT ASSIST	1
98	12483	PLATE 1/4x4x17 ASSIST BAR BACK	1
52	02513	SCREW HX HD CAP 3/8-16x1-3/4	4
99	02523	WASHER LOCK SPLIT 3/8 ZINC	4
18	02138	NUT HX FIN 3/8-16	4

FQ400
REV A

Q400
CABINET BASE

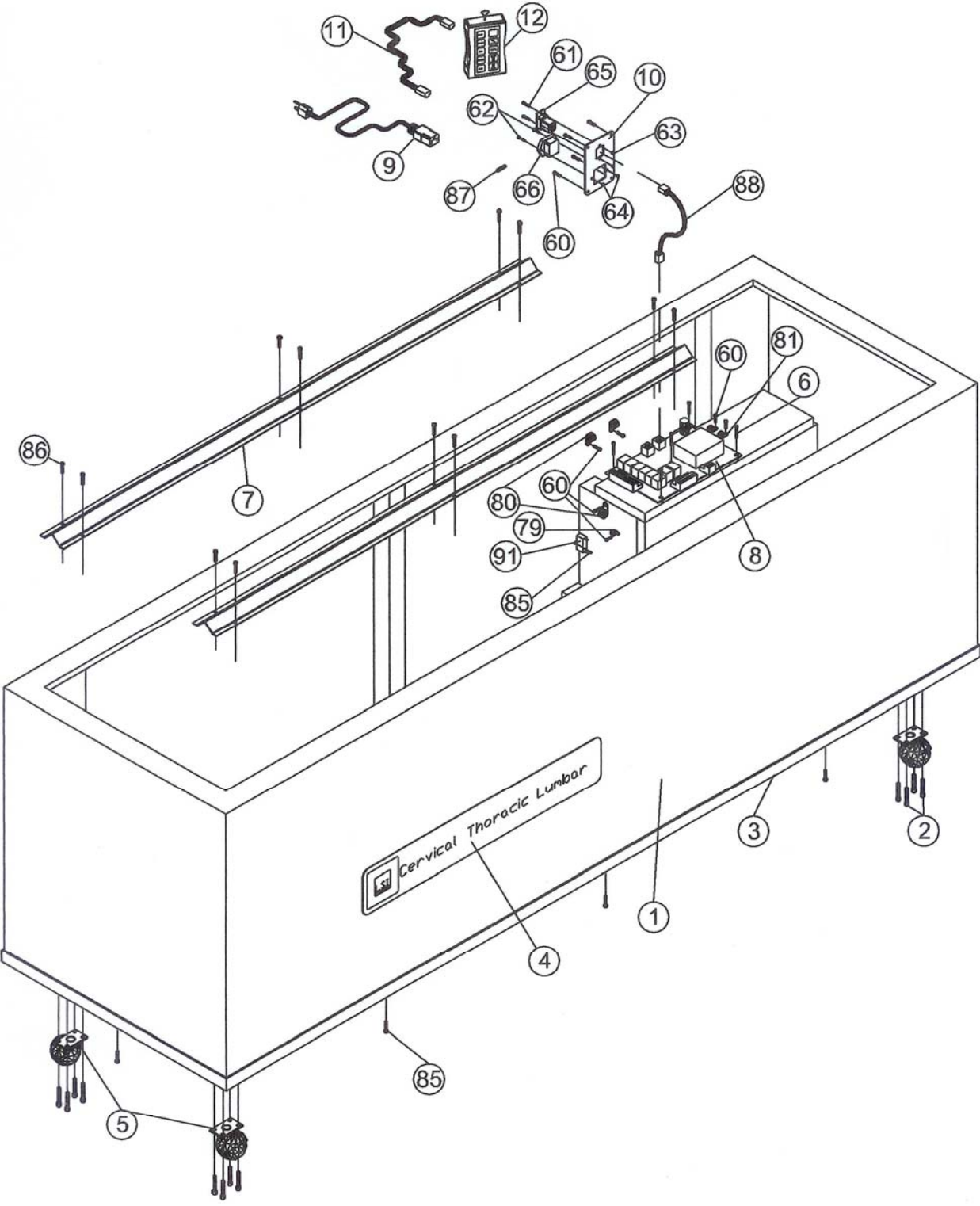

Q400
TABLE TOP

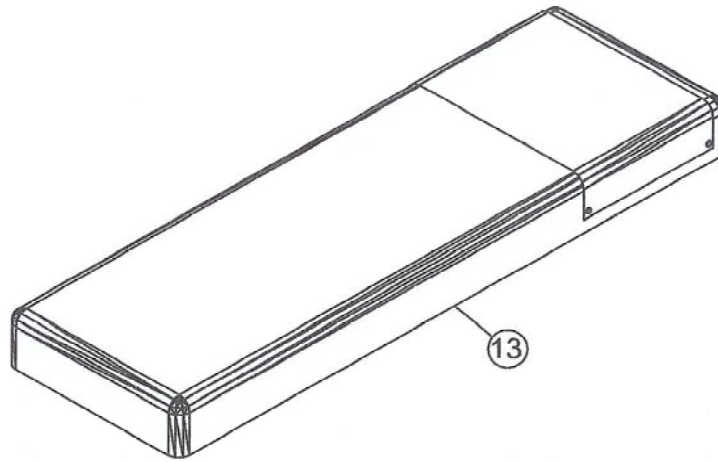

TABLE TOP
WITH FACE HOLE

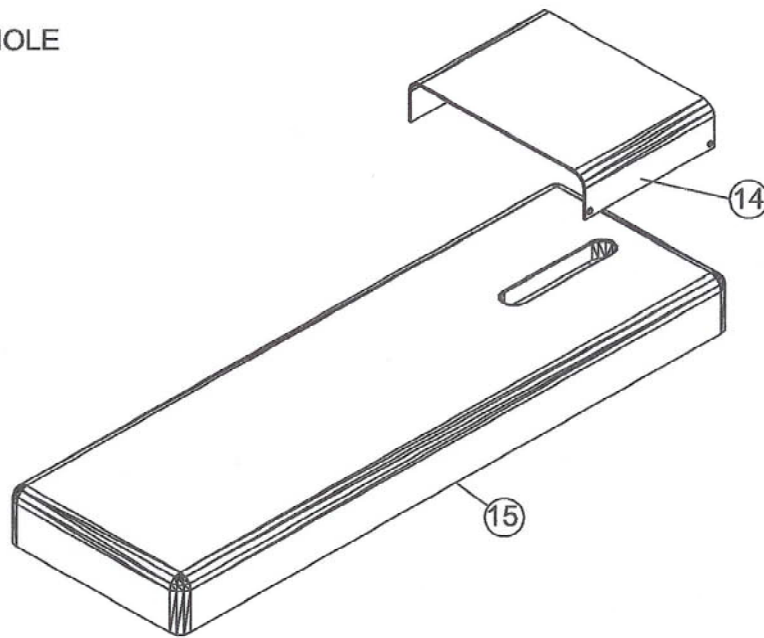
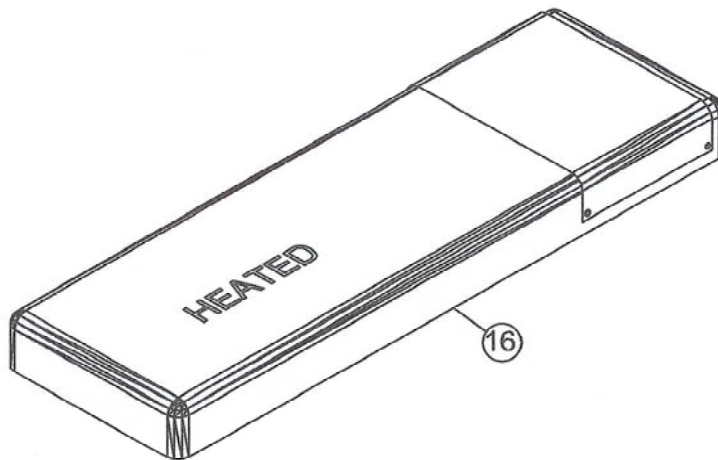
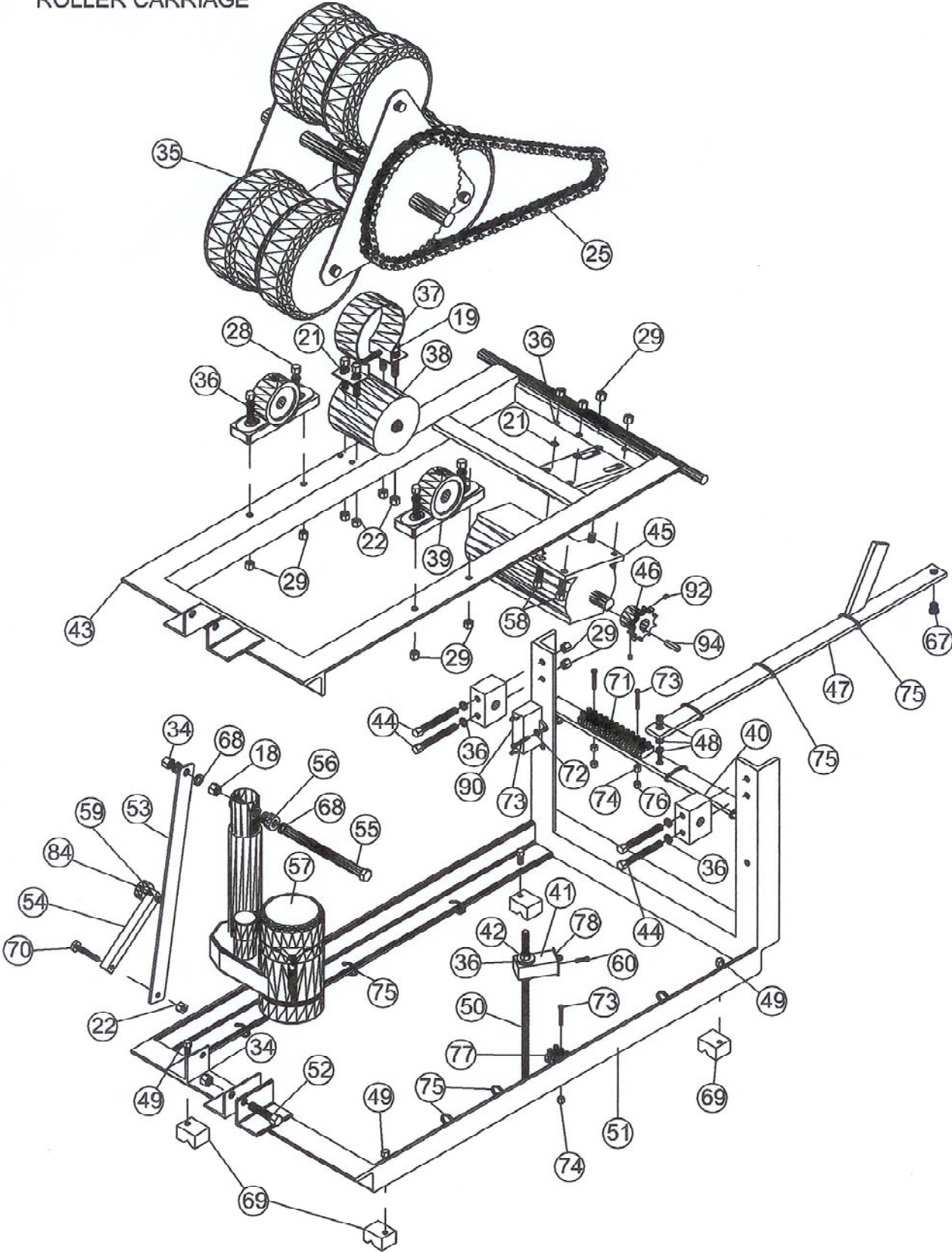

TABLE TOP
WITH HEAT



Q400
ROLLER CARRIAGE



Q400
TURN AROUND ASSEMBLY

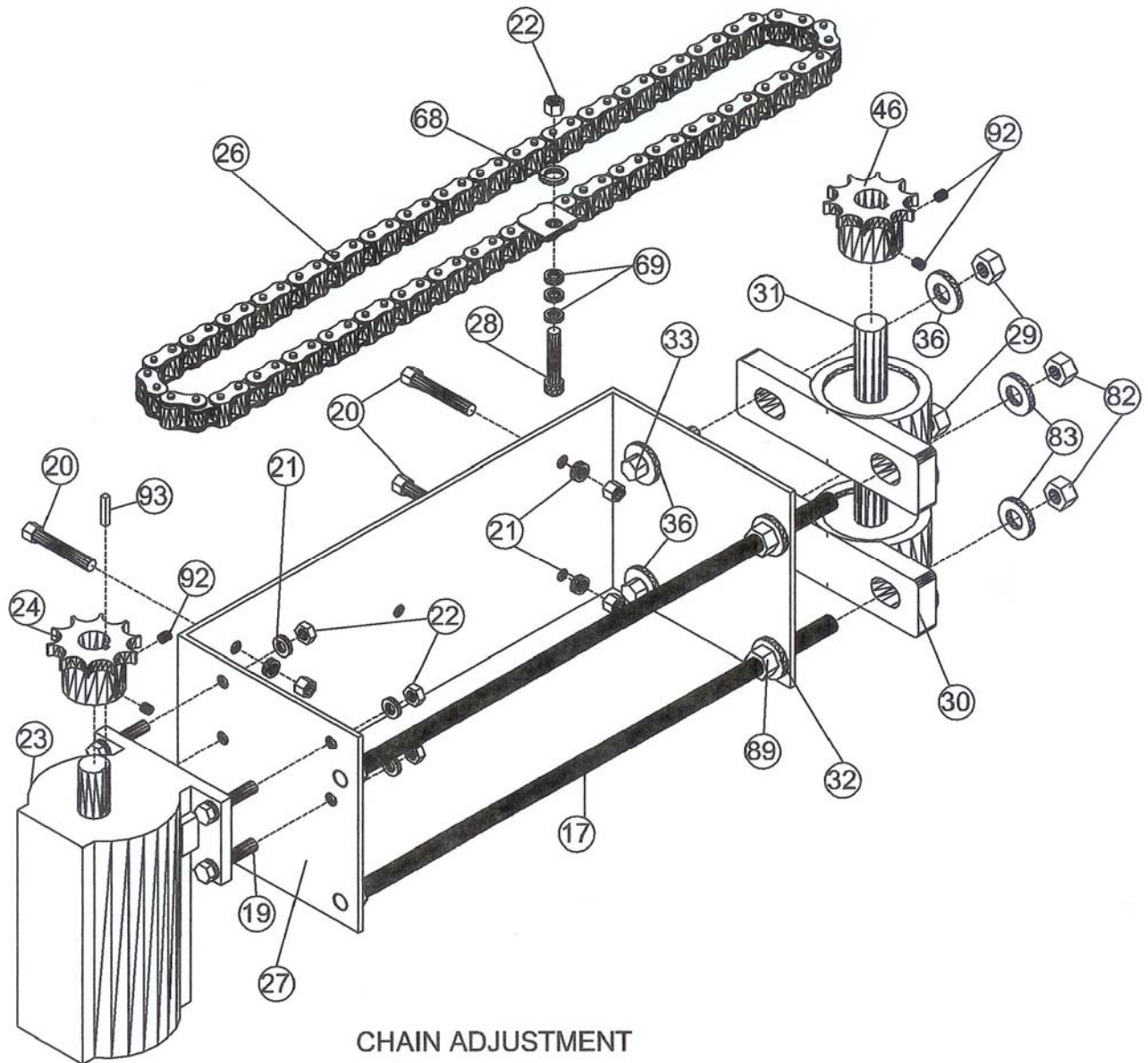

CHAIN ADJUSTMENT

3/4" open end wrench required.

Locate nuts (82) on outside ends of threaded rods (17).
Loosen nuts to allow tensioner bracket plate (27) to be spread.
Turn nuts (89) inside tensioner bracket plate to tighten chain (26).
Hold threaded rod (17) so that it doesn't turn during adjustment.

QUANTUM WIRING DIAGRAM

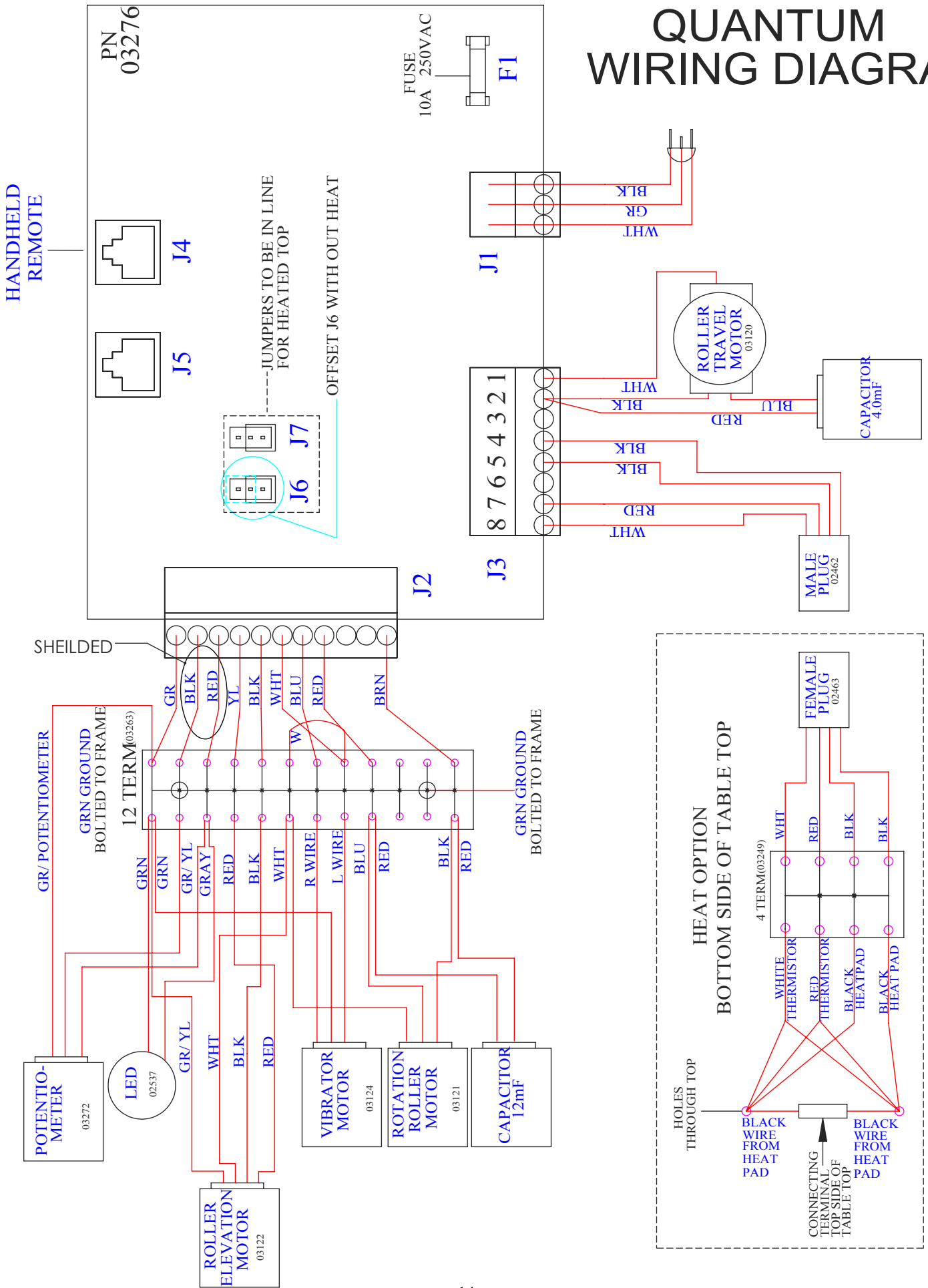

Quantum

Model No. Serial No.

Federal law restricts this device to the use by or the sale to (or on the order of) a physician or other practitioner in the state or province which said person is licensed or practices.

DANGER: Risk of explosion if used in the presence of flammable anesthetics.

115 Volts 10 Amps

Medical Electrical Equipment
With respect to electrical shock,
Fire and mechanical hazards only
In accordance w/ UL 2601-1, IEC 60601-1



Inspected By: Date: