

Lamello



P-System

The time-saving joining system
with form-locking anchoring



P-System

The time-saving joining system with form-locking anchoring

P-System – Overview	4–5	Zeta P2 – The machine for the evolving P-System, saving you time daily! Differentiate your products from the standard!	42–43
Connectors – Features overview	6–7	Accessories – Zeta P2 cordless and Zeta P2	44
Clamex P-14 – Detachable furniture connector	10–11	Connected in seconds ... Without waiting time, clamps, or secondary processes, glued and clamped in 40 seconds	45
Clamex P-14/10 Medius – Detachable connector for centre panels for materials from 16 mm thickness	12–13	Changing the cutter position – Using spacers	48
Clamex P-10 – Detachable connector for materials from 12 mm thickness	14–15	Joints in various angles – P-System grooves on edges cut to an angle	49
Clamex P-14/10 Flexus – Detachable furniture connector with flexible positioning pins	16–17	Networked production – Components for the successful integration of Lamello connection systems into your networked production	50–51
Clamex P-14 CNC – Detachable furniture connector with precise alignment	18–19	Service overview – Lamello's planning and machining partners	52–53
Application examples – Clamex P	20–21	P-System with CNC – Joining methods and requirements for CNC machines/machining options	54–57
Advantages of the Clamex P – Detachable furniture connector	22	Ideas for standardising – For CNC machines for particularly efficient machining	58–59
Bisco P – Aligning element, suitable for the P-System groove	24–25	Ideas for standardising – The machining on a CNC machine	60
Tenso P-14 – Self-clamping connector for glueing materials from 16 mm thickness	26–27	Possible combination of CNC machines with Zeta P2	61
Tenso P-10 – Self-clamping connector for glueing thin materials from 12 mm thickness	28–29	CNC tools – For the P-System	62–63
Application examples – Tenso P	30–31	Technical information	64–67
Divario P-18 – Self-clamping, invisible connector for slide insertion	32–33	Accessories/Spare Parts – P-System	68–71
Application examples – Divario P-18	34–35	We are here for you!	72–73
High performance without cable – LiHD battery pack	36–37	Overview of connectors	74–75
More flexible in the workshop	38	Overview of connectors	75
Mobile working on the construction site	39		
Zeta P2 cordless – The powerful P-System biscuit joiner for cordless freedom	40–41		



Features

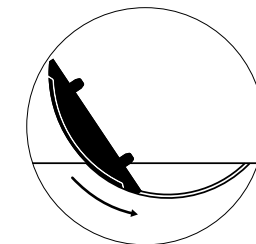

Fast installation
Inserting instead of screwing or glueing

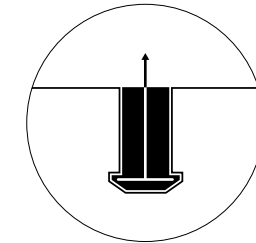

Strong
Form-locking anchorage across large surface areas

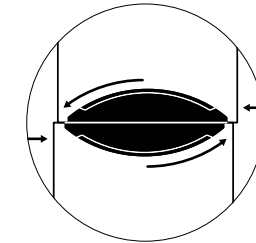

Lateral tolerance
Perfect, flush alignment of both workpieces

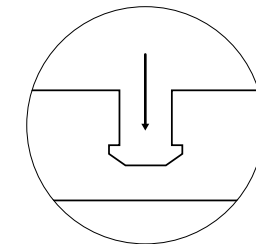

Shallow depth
Minimal cutting depth with maximum tensile strength

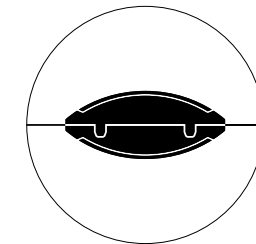

No twisting
The positioning pins prevent twisting without additional dowels

P-System

Overview

Joining methods	Connector	Machines		Sequence			
		Power tool	CNC machines	1 Cut	2 Insert the connector	3 Deliver flat pack	4 Connect the workpieces

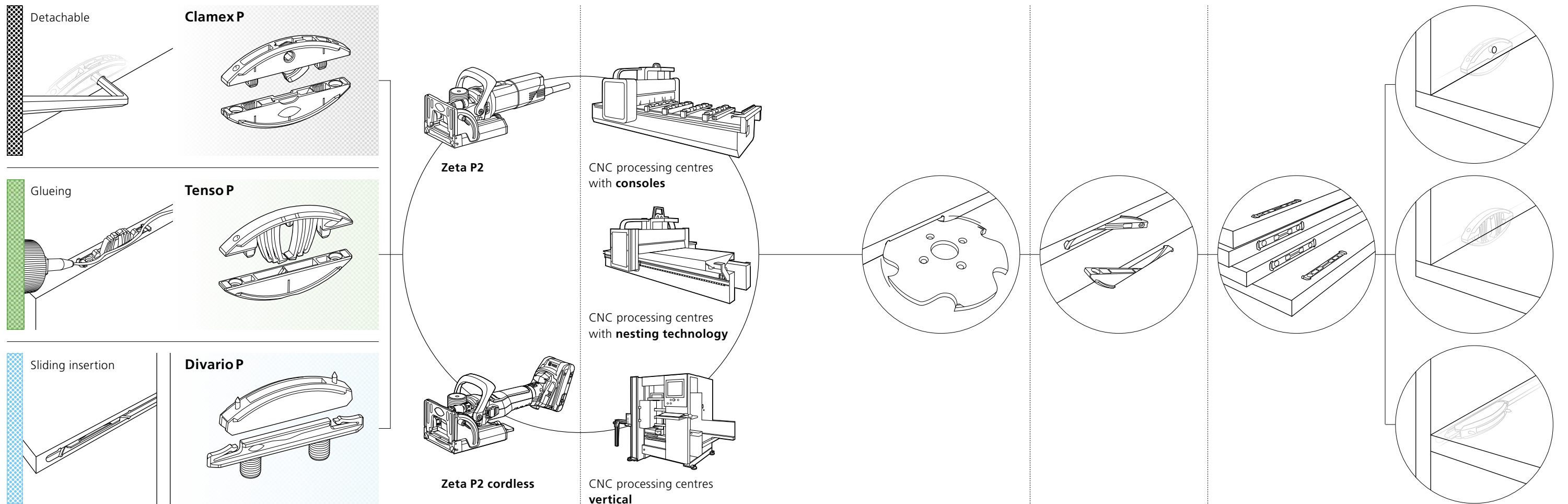

Connectors

Features overview

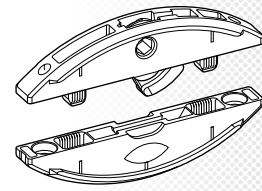

Clamex P

Detachable furniture connector

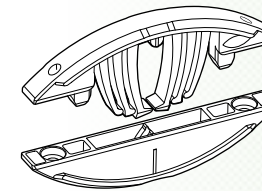

Tenso P

Self-clamping connector for glueing

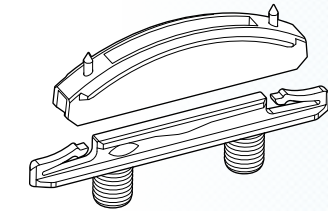

Divario P

Self-clamping, invisible connector for slide insertion

Features

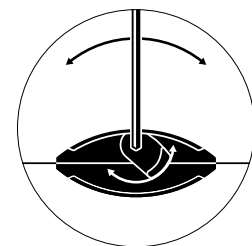

Detachable
Open the connection time and time again with the rotating lever

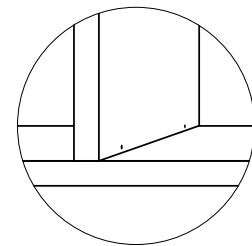

Aesthetic
The small, hardly visible opening ($\varnothing = 6 \text{ mm}$) serves to close and open the connector

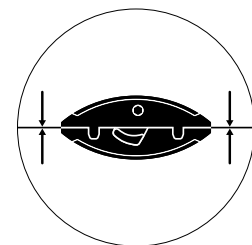

High clamping force
Clamp and glue workpieces at any angle, ~ 80 kg or 170 lb

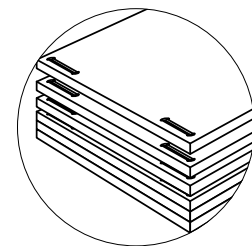

Stackable
Workpieces with pre-installed P-System connectors are stackable for storage and transport

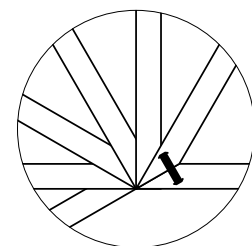

Versatile
The shallow element depth allows for mitres from 22.5 – 180°, surface, corner and dividing panel connections

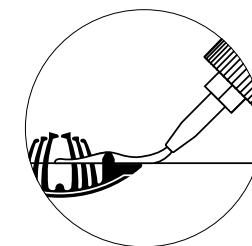

Glueing
Fixed joints of two workpieces

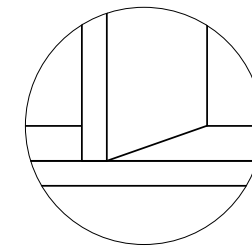

Invisible
No visible connector

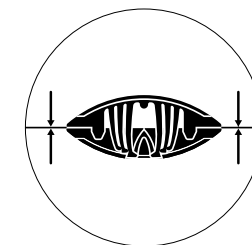

High clamping force
Allows for perfect alignment and clamps the workpieces ~ 15 kg or 30 lb

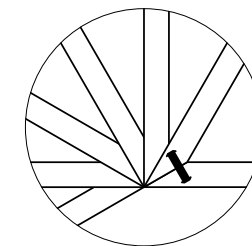

Versatile
Simple glueing of mitre joints

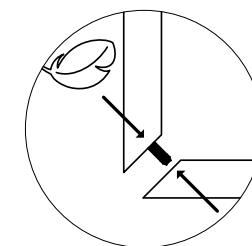

Lower assembly force
In combination with the pretension clip, only a short force impulse is required to snap it into place

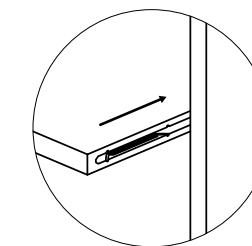

Sliding insertion
Insertion between two fixed sides or shelves via a guiding groove

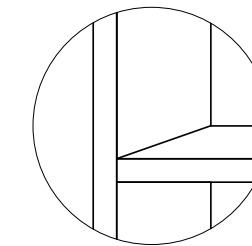

Invisible
Guiding groove covers the connectors

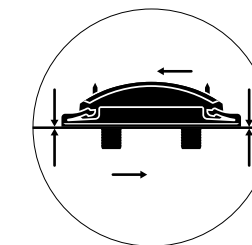

Clamped joint
No resistance while inserting until shortly before building the clamping force

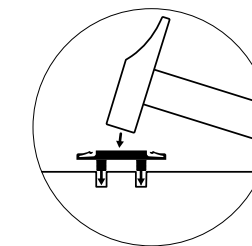

Fast installation
Quick installation of the connectors without glue after transport

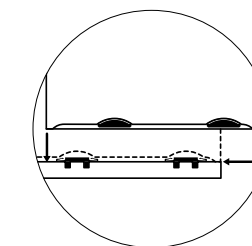

Assemble by sliding
Partially routed guiding groove for completely invisible furniture joints



*« With Tenso, simply apply glue,
assemble the parts and you're done. »*

Jeffrey De Smet, self-employed carpenter, Belgium

Clamex P-14

Detachable furniture connector



Features

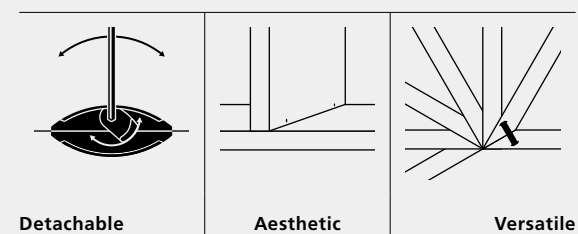

Clamex P-14 is a detachable connector and is anchored in the form-locking P-System groove within seconds.

Through the minimalist 6 mm access hole, Clamex P-14 is firmly connected and disconnected using a lever.

Clamex P-14 eliminates the need for glue, allows aesthetic joints at all angles and is ideal for permanently joined or detachable mitres. Clamex P-14 is used on mitre joints from 18 mm material thickness and in butt joints from 15 mm.

Articles



Clamex P-14	Art. No.
80 pairs	145334
300 pairs	145346
1000 pairs	145356
2000 pieces element with lever	145338
2000 pieces element without lever	145339

www.lamello

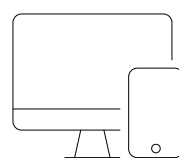

Experience the connector live and receive comprehensive product information!



Function

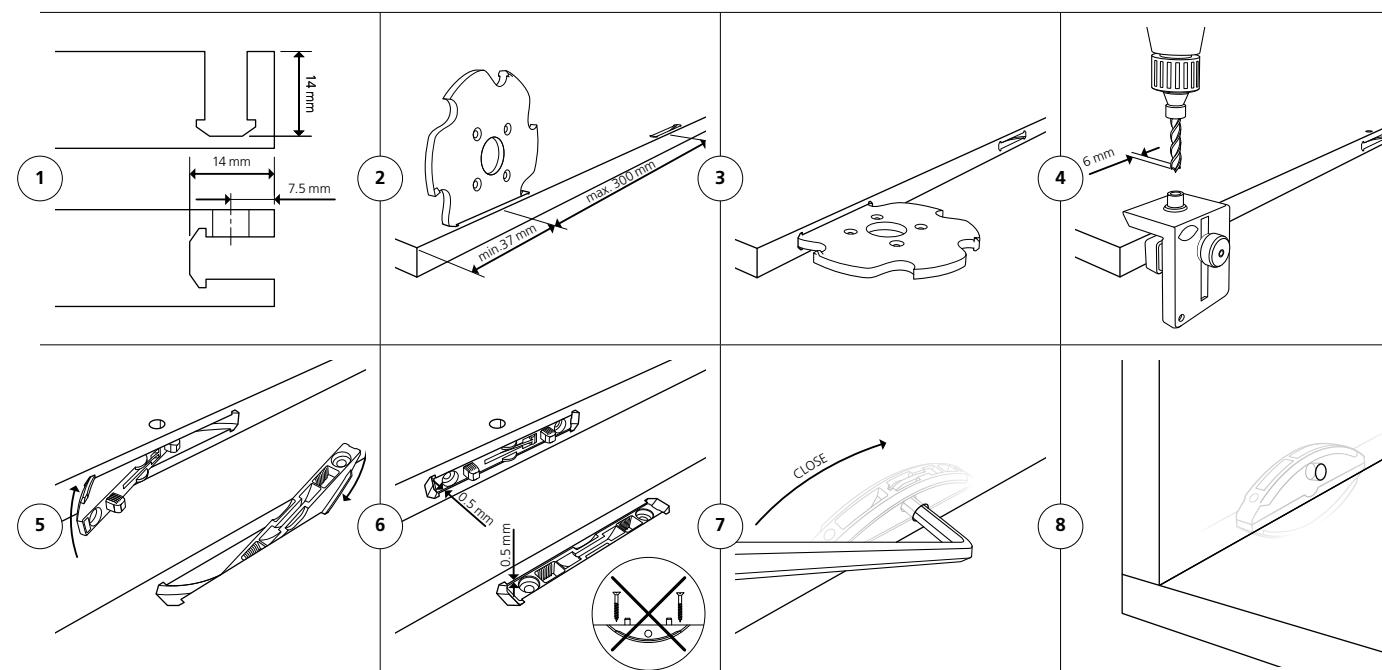

Technical data

Joining methods

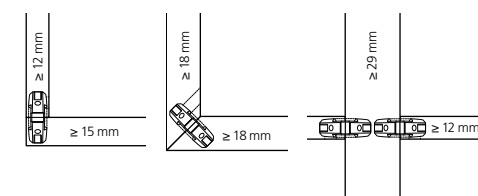

Size	64 × 27 × 9.7 mm		
Cutter	Ø 100.4 × 7 × Ø 22 mm		
Material connector	Fiberglass reinforced plastic		
Material of lever	Zinc die cast		
Installation tolerance	Long. ± 1 mm/radial ± 1 mm		
Tensile strength (N) Up to	MDF 900 ¹	Particle board 800 ¹	Beech 1000 ¹
Material range	Particle board, MDF, plywood, softwood, hardwood etc.		

Clamex P-14/10 Medius

Detachable connector for centre panels for materials from 16 mm thickness



Features

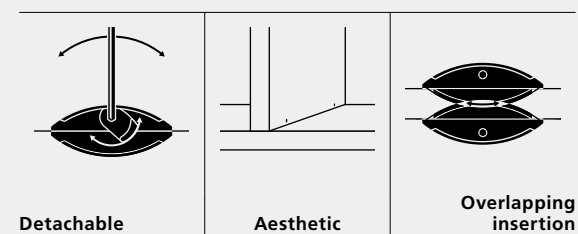

Clamex P-14/10 Medius is a detachable connector and is anchored in the form-locking P-System groove within seconds.

Through the minimalist 6 mm access hole, Clamex P-14/10 Medius is firmly connected and disconnected using a lever.

The connector for divisions has two installation depths and is used when two shelves are attached to the same dividing panel at the same height. Due to the reduced installation depth of 10 mm, the minimal thickness for the division is 16 mm.

Articles



Clamex P-14/10 Medius	Art. No.
80 pairs	145370
300 pairs	145371
1000 pairs	145357
2000 pieces element with lever	145338
2000 pieces element without lever	145369

Function

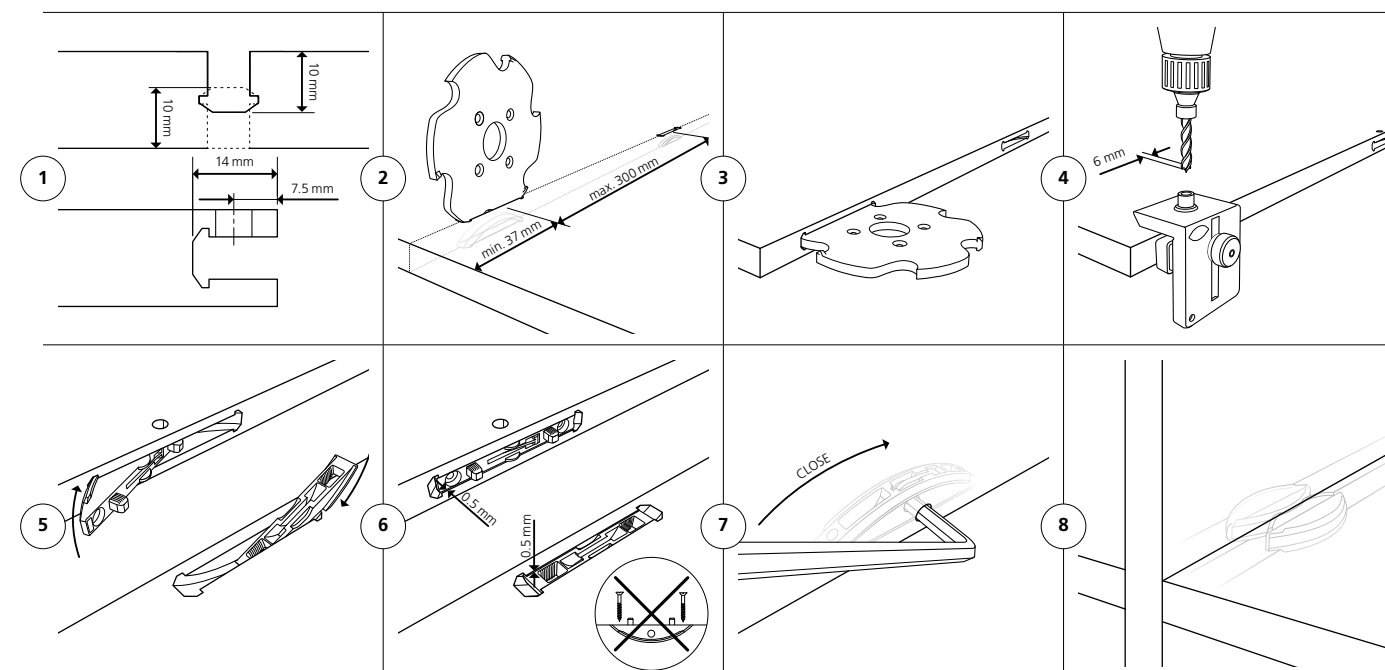

Technical data

Joining methods	Size	64 x 13.5 x 9.7 mm 52 x 7.5 x 9.7 mm		
	Cutter	Ø 100.4 x 7 x Ø 22 mm		
	Material connector	Fiberglass reinforced plastic		
	Material of lever	Zinc die cast		
	Installation tolerance	Long. ± 1 mm/radial ± 1 mm		
	Tensile strength (N) Up to	MDF 800 ¹	Particle board 600 ¹	Beech 900 ¹
	Material range	Particle board, MDF, plywood, softwood, hardwood etc.		

90° and 45° cover caps are available in a variety of colours **PAGE 69** | See **PAGE 64** for technical specifications

¹ See comment on load limits on **PAGE 75**

www.lamello

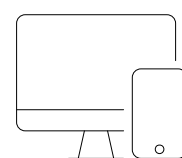

Experience the connector live and receive comprehensive product information!



Clamex P-10

Detachable connector for materials from 12 mm thickness



Features

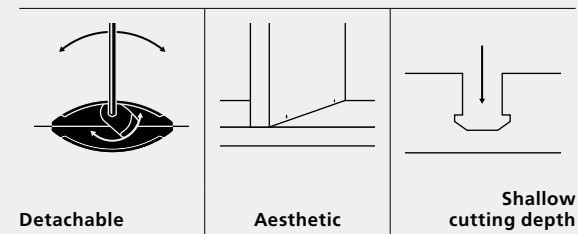

Clamex P-10 is a detachable connector and is anchored in the form-locking P-System groove within seconds.

Through the minimalist 6 mm access hole, Clamex P-10 is firmly connected and disconnected using a lever.

Clamex P-10 eliminates the need for glue, allows aesthetic joints at all angles and is ideal for permanently joined or detachable mitres.

Clamex P-10 is used on mitre joints from 15 mm material thickness and in butt joints from 12 mm.

Articles



Clamex P-10	Art. No.
80 pairs	145372
300 pairs	145373
1000 pairs	145374
2000 pieces element without lever	145358

Function

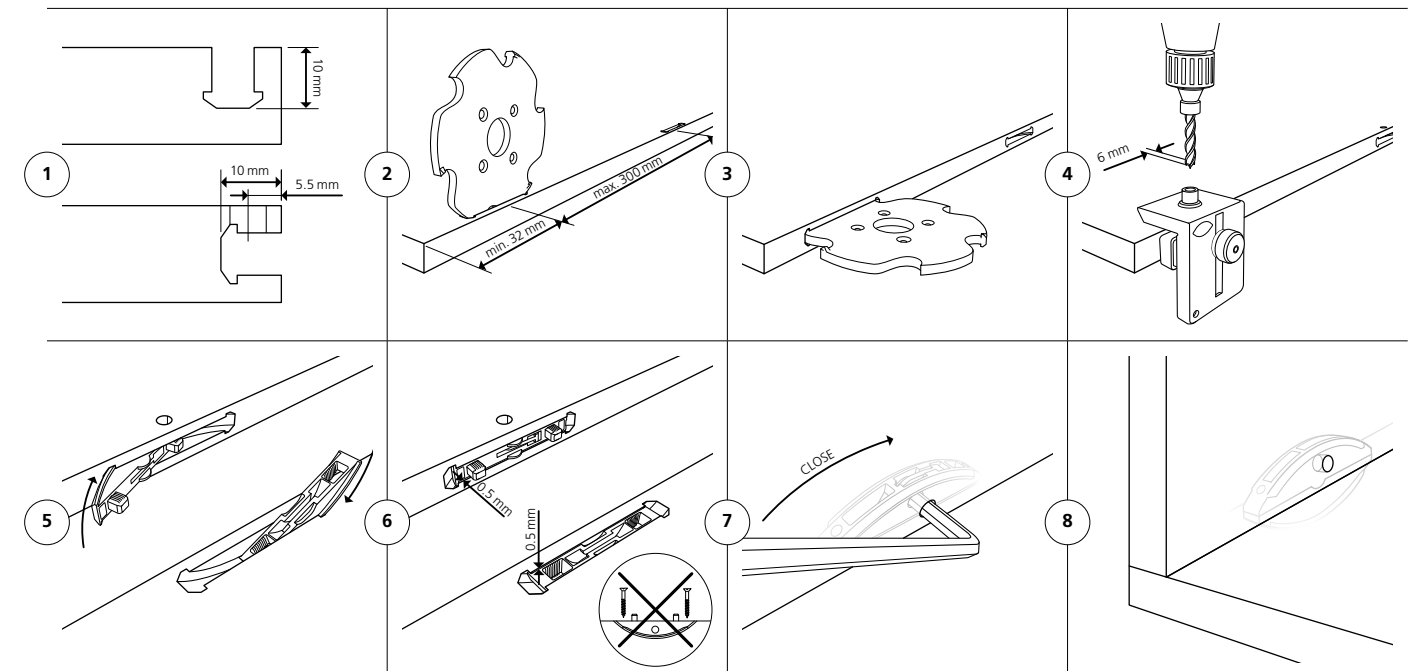

www.lamello

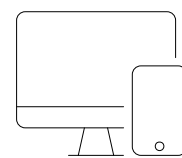

Experience the connector live and receive comprehensive product information!

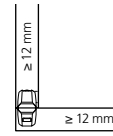
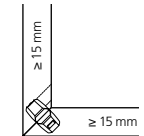
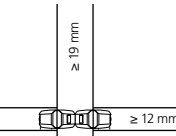

Technical data

Joining methods	Size	52 x 19 x 9.7 mm		
	Cutter	Ø 100.4 x 7 x Ø 22 mm		
	Material connector	Fiberglass reinforced plastic		
	Material of lever	Zinc die cast		
	Installation tolerance	Long. ± 0.5 mm/radial ± 0.5 mm		
	Tensile strength (N) Up to	MDF 600 ¹	Particle board 600 ¹	Beech 900 ¹
	Material range	Particle board, MDF, plywood, softwood, hardwood etc.		

See **PAGE 64** for technical specifications | ¹ See comment on load limits on **PAGE 75**

Clamex P-14/10 Flexus

Detachable furniture connector with flexible positioning pins



Features

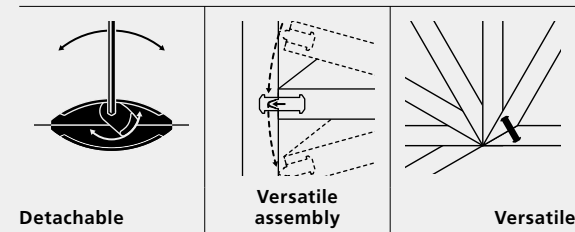

Clamex P-14/10 Flexus is a detachable connector and is anchored in the form-locking P-System groove within seconds.

Through the minimalist 6 mm access hole, Clamex P-14/10 Flexus is firmly connected and disconnected using a lever.

The flexible positioning pins allow work pieces to be installed in an already assembled cabinet, simplifying the assembly sequence.

Clamex P-14 is used in mitre joints from 18 mm material thickness and in butt joints from 12 mm.

Articles



Clamex P-14/10 Flexus	Art. No.
80 pairs	145315
300 pairs	145316
1000 pairs	145317
2000 pieces element with lever	145318
2000 pieces element without lever	145369

Function

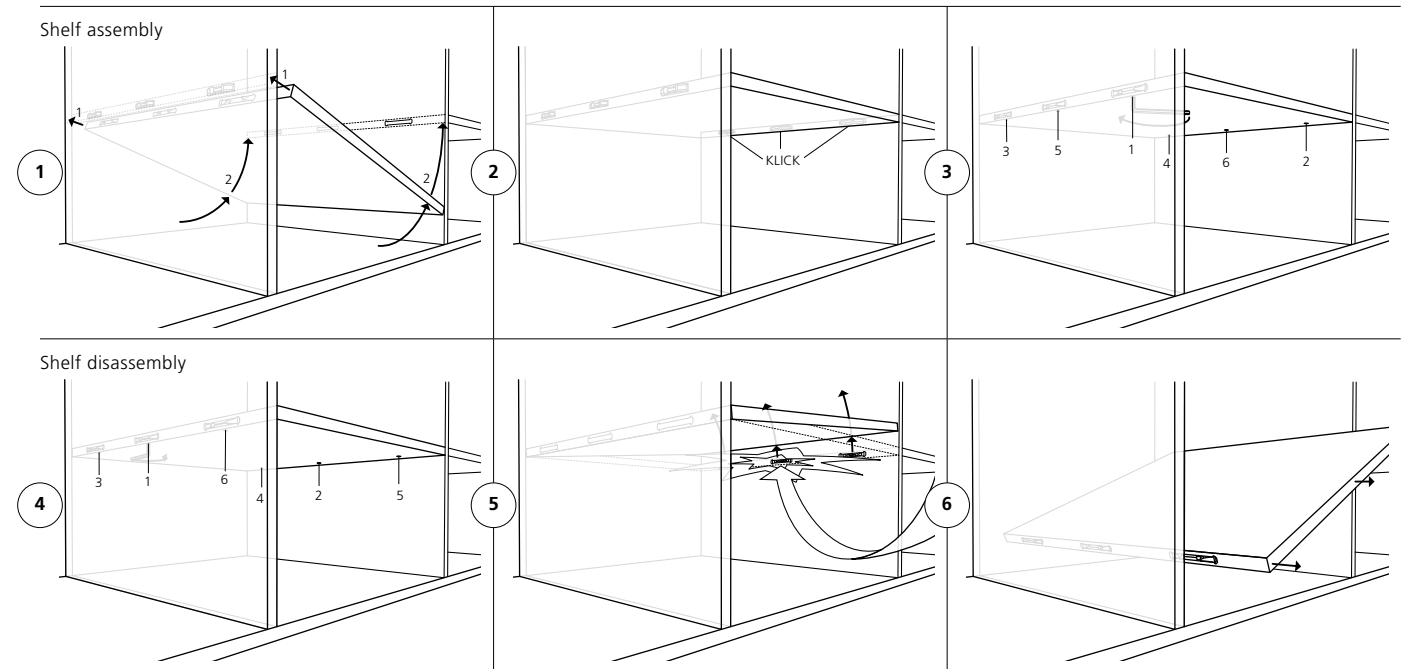

www.lamello

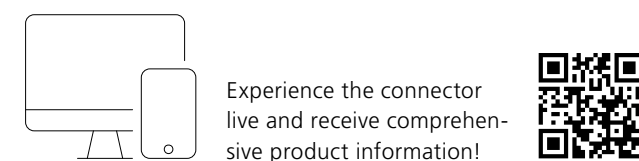

Technical data

Joining methods	Size	64 × 13.5 × 9.7 mm 52 × 7.5 × 9.7 mm
	Cutter	Ø 100.4 × 7 × Ø 22 mm
	Material connector	Fiberglass reinforced plastic
	Material of lever	Zinc die cast
	Installation tolerance	Long. ± 0 mm/radial ± 1 mm
	Tensile strength (N) Up to	MDF 720 ¹ Particle board 600 ¹ Beech 810 ¹
	Material range	Particle board, MDF, plywood, softwood, hardwood etc.

See **PAGE 65** for technical specifications | ¹ See comment on load limits on **PAGE 75**

Clamex P-14 CNC

Detachable furniture connector with precise alignment



Features

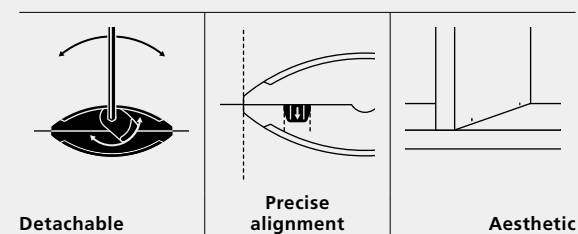

Clamex P-14 CNC is a detachable connector and is anchored in the form-locking P-System groove within seconds. Through the minimalist 5 mm access hole, Clamex P-14 is firmly connected and disconnected using a lever.

Clamex P-14 CNC is ideal for production on CNC machines and, unlike Clamex P-14, is automatically aligned during assembly.

Clamex P-14 CNC is used in mitre joints from 18 mm material thickness and in butt joints from 12 mm.

Articles

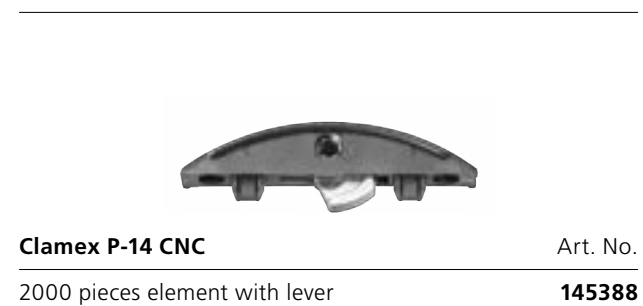

www.lamello

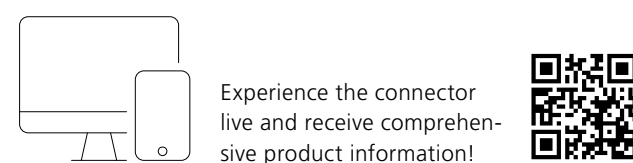

Function

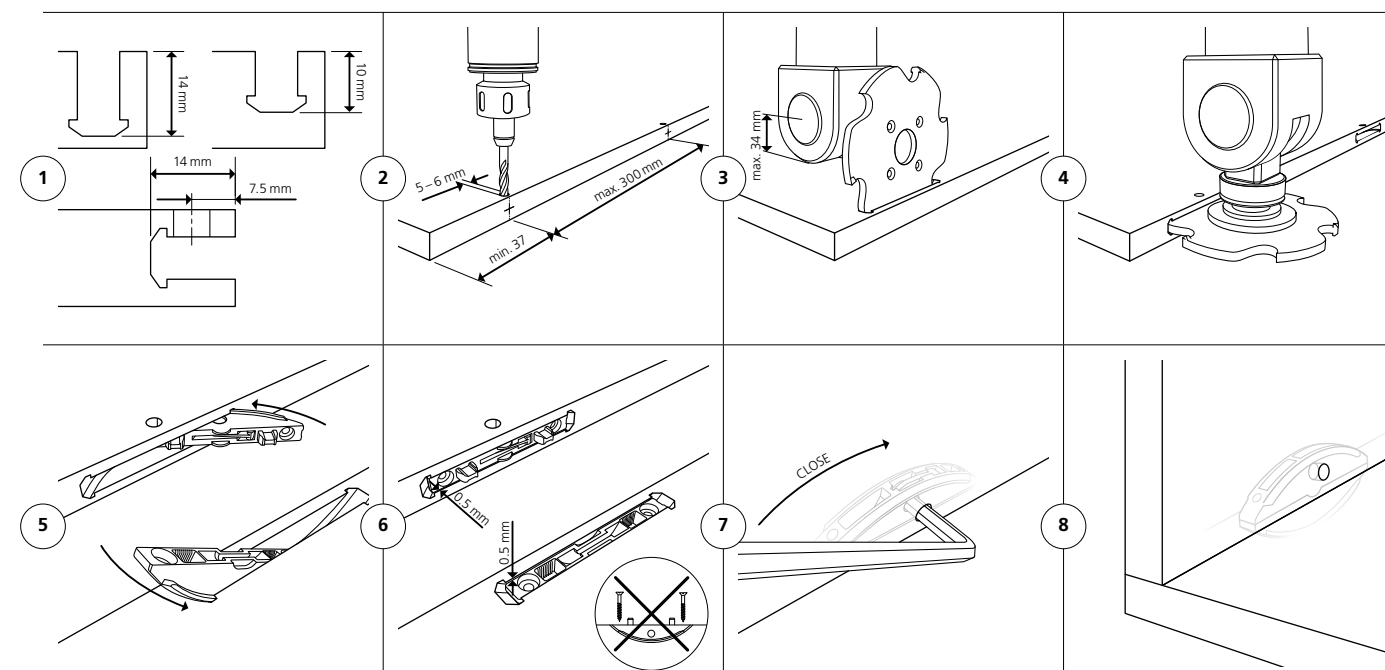

Technical data

Joining methods

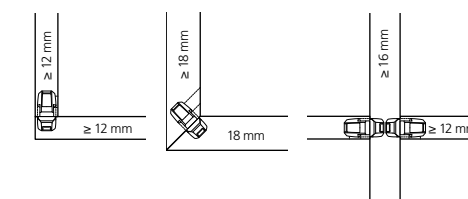

Size	64 × 13.5 × 9.7 mm
Cutter	Ø 100.4 × 7 × Ø 22 mm
Material connector	Fiberglass reinforced plastic
Material of lever	Zinc die cast
Installation tolerance	Long. ± 0 mm/radial ± 1 mm
Tensile strength (N)	Depending on the connector combination*
Material range Up to	Particle board, MDF, plywood, softwood, hardwood etc.

* See PAGE 65 for technical specifications

Application examples

Clamex P

Furniture manufacturing/Interior fitting: Sideboards, shelves, wardrobes, trade show exhibits (display cases), kitchen furniture, TV furniture etc.

Shop fitting/Kitchen manufacturing: Wall elements, furniture, trade show exhibits (display cases), trade show exhibits, changing rooms, stools etc.

Clamex P-14/10
Flexus



Clamex P-14 CNC



Clamex P-10



Clamex P-14/10
Medius



Clamex P-14

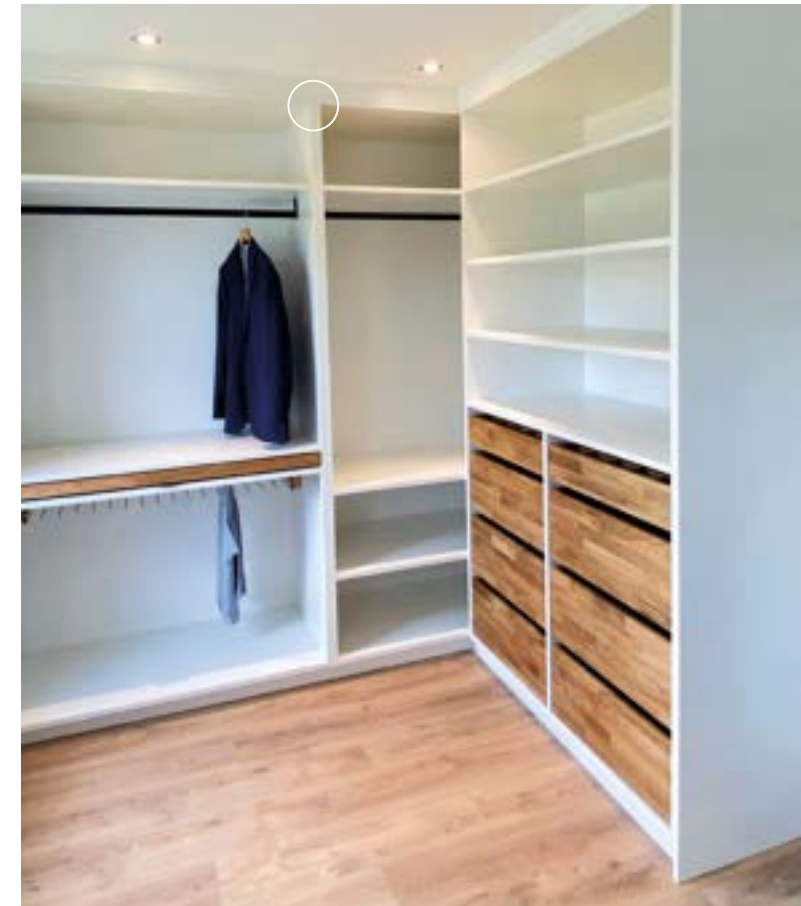

Advantages of the Clamex P

Detachable furniture connector



« The P-System saves us an enormous amount of time in production. Our fitters are big fans of Clamex and now they don't want to work with anything else. »

Markus Fust, Managing Director,
Fust Schreinerei AG, Wil, Switzerland

1. Advantages in production



- Machining possible with Zeta P2 or CNC machinery
- Only one tool change from P-System cutter to 6 mm drill
- Same groove everywhere: whether corner connection, shelf, centre panel or mitres
- Consistently competent partners: from CAD to CAM and CNC

2. Advantages in transportation



- Tool-free connector installation
- Workpieces with pre-installed P-System connectors are stackable for storage and transport
- No extra bags or loose hardware required with furniture shipment
- Tool-free connector disassembly for surface treatment

3. Advantages in assembly



- Simple positioning of workpieces thanks to positioning pins
- Easy assembly with an Allen key
- Aesthetically small, barely visible hole (Ø = 6 mm)
- Open the connection time and time again with the rotating lever
- Lateral tolerance perfect, flush alignment of both workpieces

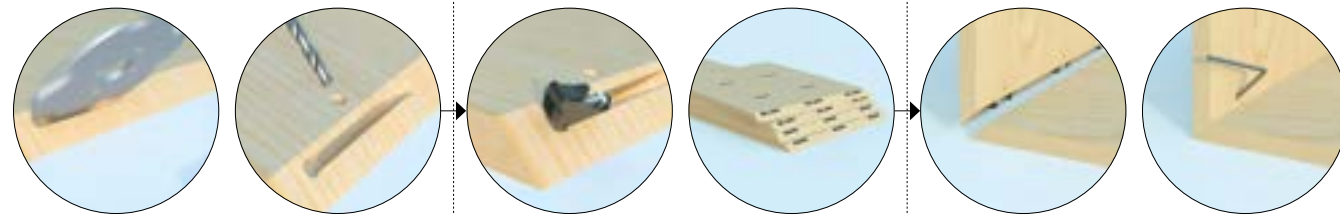

1. Machining with a Zeta P2 or CNC machine

2. Only one tool change

3. Tool-free connector installation

4. Flat pack delivery

5. Versatile for all angles and joining situations

6. Strong and detachable connection

Bisco P

Aligning element, suitable for the P-System groove

Features

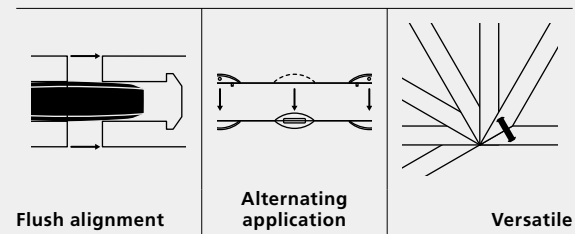

Bisco P is a plastic biscuit which fits into the 7 mm P-System groove and is held in the groove due to its surface structure. Bisco P is used in combination with Clamex or Tenso as a cost-effective alignment element and ensures flushness of the joint. The Bisco can also be used as a dry joint as a test before the work piece is permanently joined with Tenso P and adhesive.

Bisco P-14 is used in combination with Clamex P-14 or Tenso P-14; and Bisco P-10 with the same connectors in size P-10.

Articles

	Art. No.
Bisco P-14	
80 pieces	145301
300 pieces	145302
1000 pieces	145303

	Art. No.
Bisco P-10	
80 pieces	145304
300 pieces	145305

Function

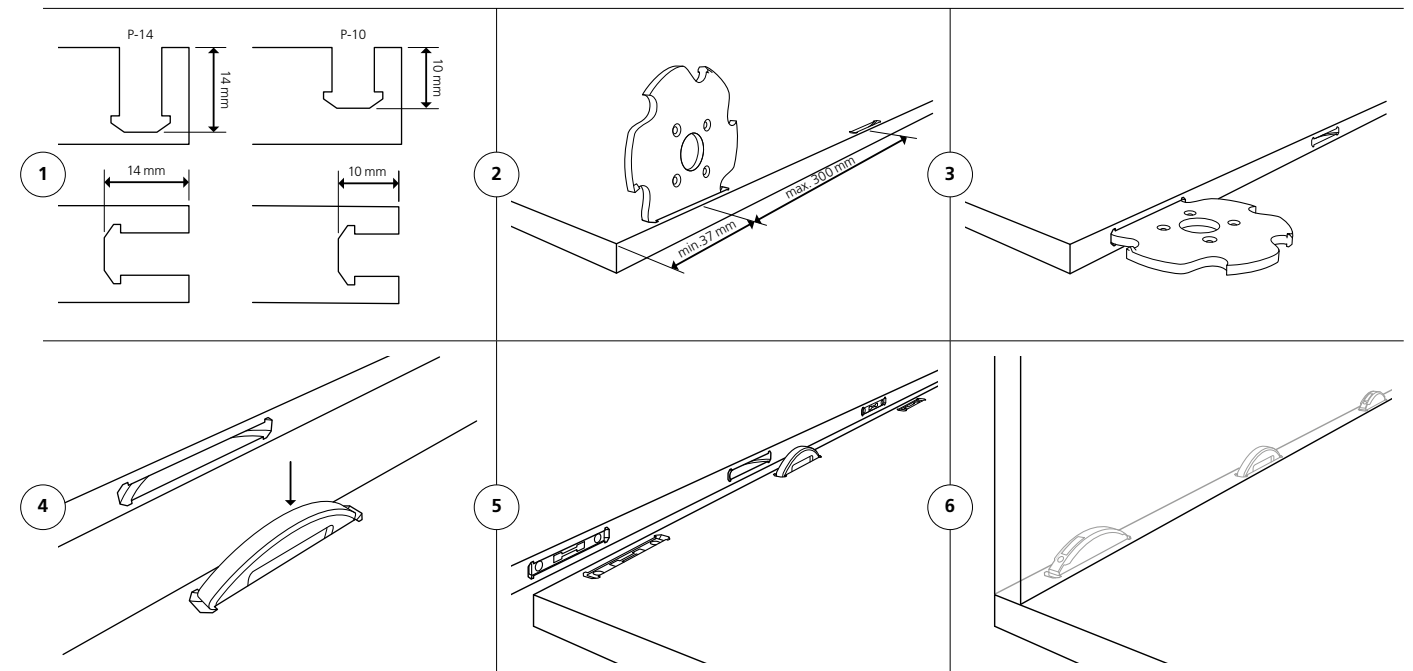

Technical data

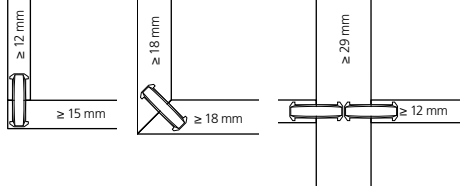
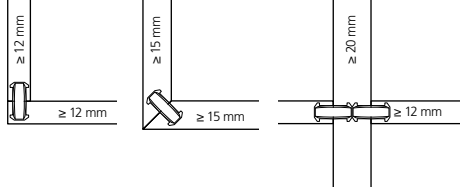
Joining methods	Bisco P-14
	Size 65 x 27 x 7 mm
	Cutter Ø 100.4 x 7 x Ø 22 mm
	Material connector Plastic
	Installation tolerance Long. ± 2 mm
	Tensile strength (N) Depending on the connector combination*
Joining methods	Bisco P-10
	Size 52 x 19 x 7 mm
	Cutter Ø 100.4 x 7 x Ø 22 mm
	Material connector Plastic
	Installation tolerance Long. ± 2 mm
	Tensile strength (N) Depending on the connector combination*
	Material range Particle board, MDF, plywood, softwood, hardwood etc.

www.lamello

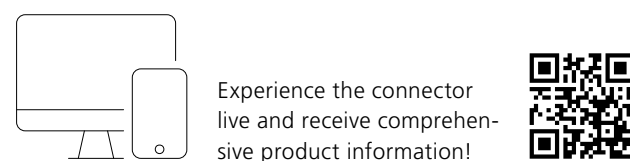

* See PAGE 66 for technical specifications

Tenso P-14

Self-clamping connector for glueing materials from 16 mm thickness



Features

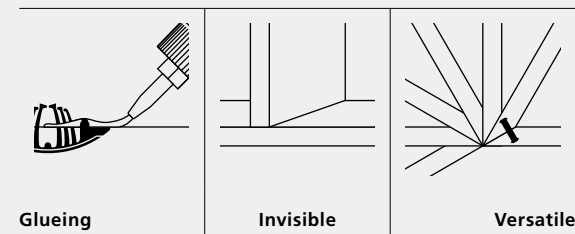

Tenso P-14 is a self-clamping glueing aid and is anchored in the form-locking P-System groove within seconds.

The high clamping force of Tenso leads to perfectly clamped joints without the need for clamps or presses, regardless of the angle of the work pieces.

Aesthetic joining is possible without visible connectors, with short assembly times and without the need to wait for the glue to dry. Tenso P-14 is used on mitre joints from 18 mm material thickness and in butt joints from 15 mm.

Articles

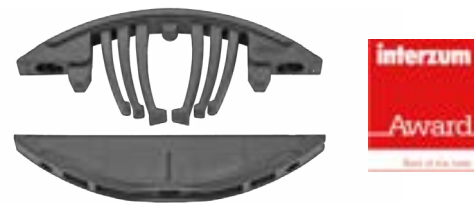

Tenso P-14	Art. No.
80 pairs	145415
80 pairs, with preload clip	145415S
300 pairs	145425
300 pairs, with preload clip	145425S
1000 pairs	145435
2000 pieces element with spring	145440
2000 pieces element without spring	145441



Tenso P-14 preload clip	Art. No.
300 pieces	145426
1000 pieces	145436

www.lamello

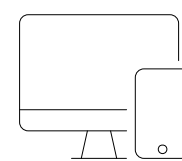

Experience the connector live and receive comprehensive product information!



Function

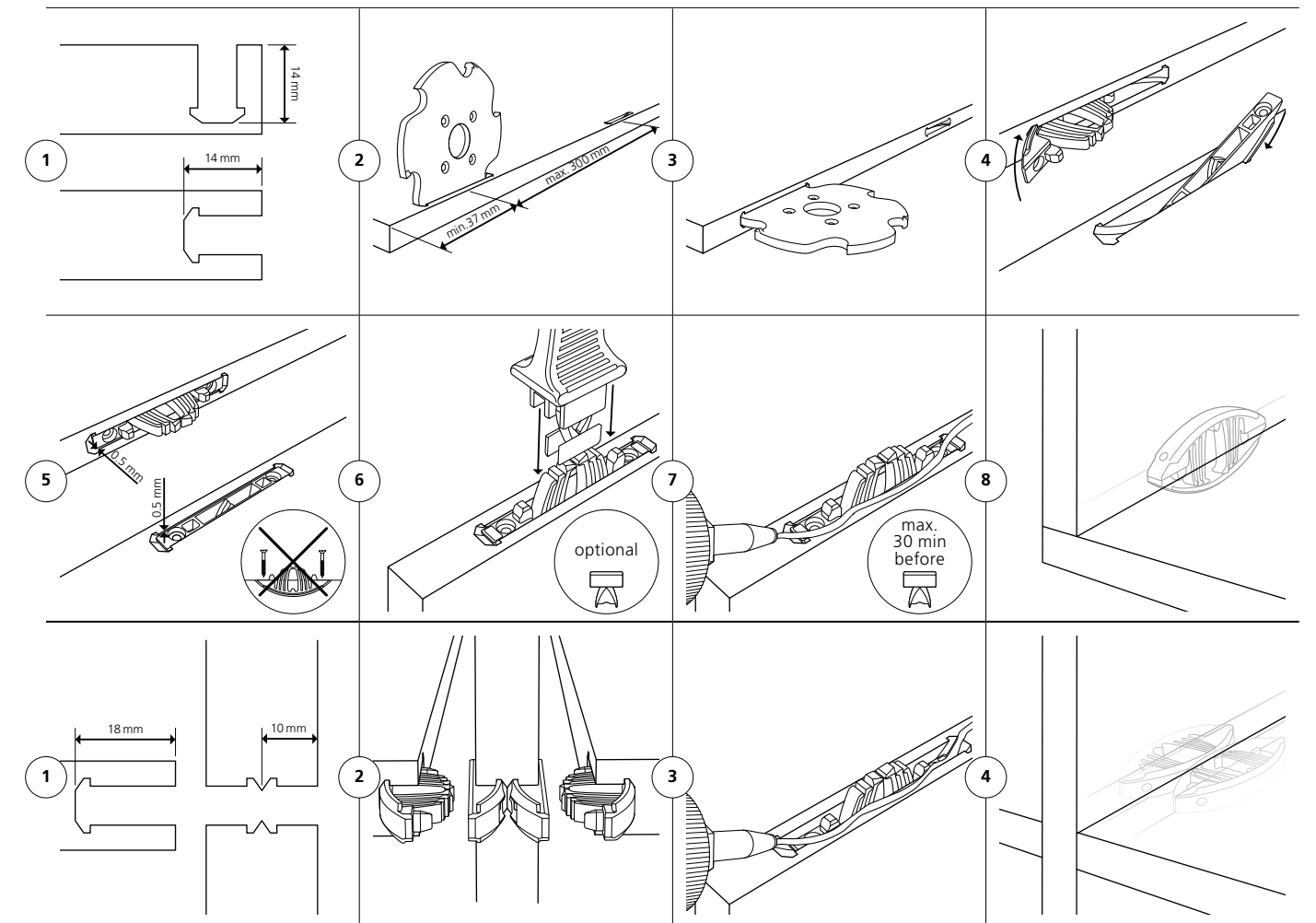

Technical data

Joining methods

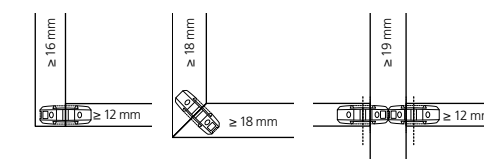

Important: The aligning element Bisco P-14 is ideal to dry-assemble the joints before glueing

Size	66 × 27 × 9.7 mm
Cutter	Ø 100.4 × 7 × Ø 22 mm
Material connector	Fiberglass reinforced plastic
Installation tolerance	Long. ± 1 mm/radial ± 1 mm
Tensile strength (N)	Depending on the adhesive
Material range	Particle board, MDF, plywood, softwood, hardwood etc.

See **PAGE 67** for technical specifications

Tenso P-10

Self-clamping connector for glueing thin materials from 12 mm thickness



Features

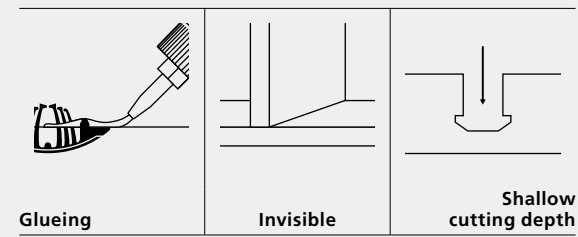

Tenso P-10 is a self-clamping connector to glue and is anchored in the form-locking P-System groove within seconds.

The high clamping force of Tenso leads to perfectly clamped joints without clamps or presses, regardless of the angle of the work pieces.

Aesthetic joining is possible without visible connectors, with short assembly times and without having to wait or the glue to dry. Tenso P-10 is used on mitre joints from 15 mm material thickness and in butt joints from 12 mm.

Articles

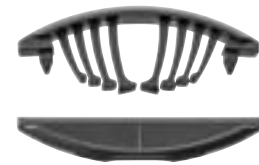

Tenso P-10	Art. No.
80 pairs, with preload clip	145418
300 pairs, with preload clip	145428
1000 pairs, with preload clip	145438
2000 pieces element with spring	145442
2000 Pieces element without spring	145443



Tenso P-10 preload clip	Art. No.
2000 pieces	145445

Function

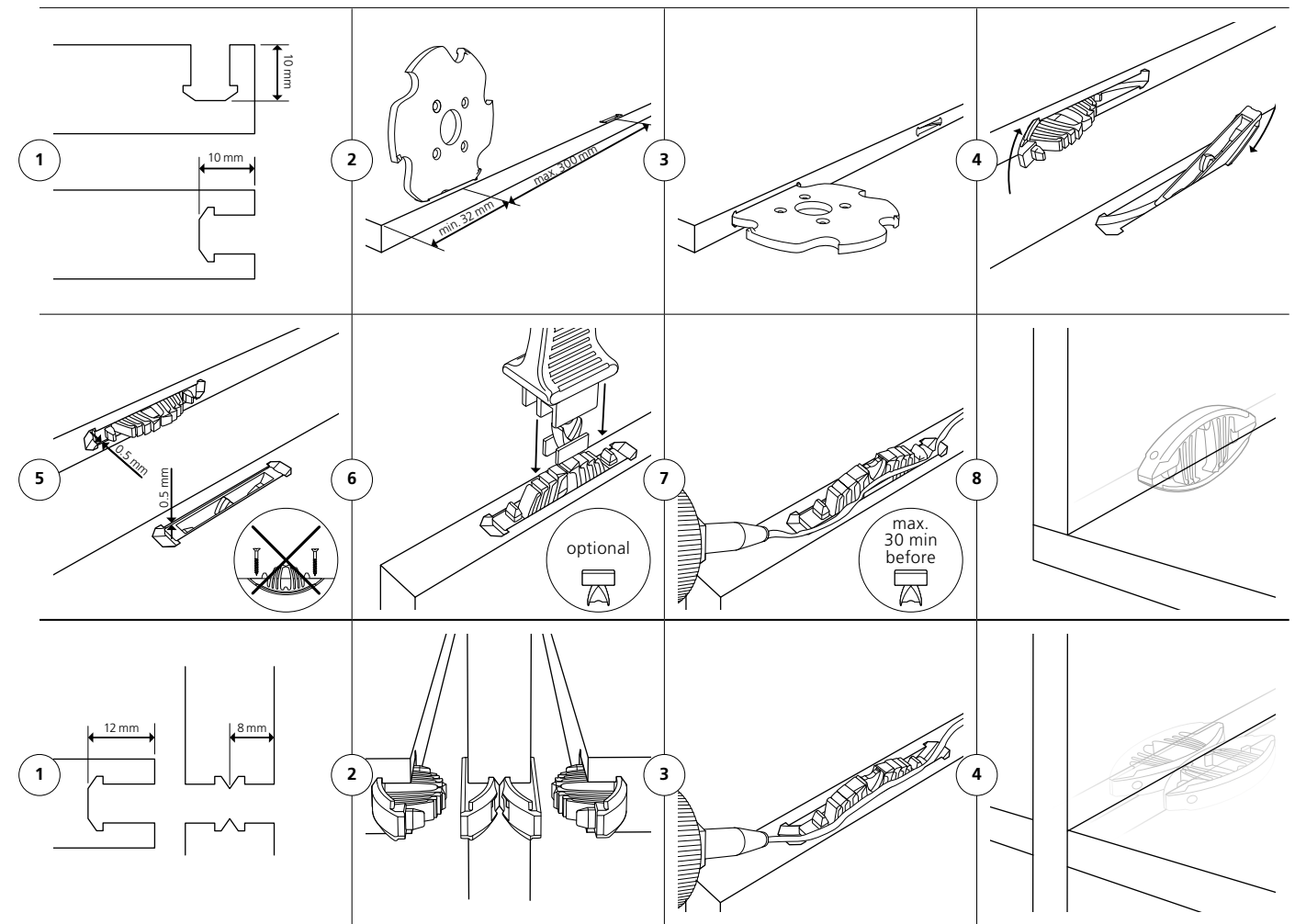

Technical data

Joining methods

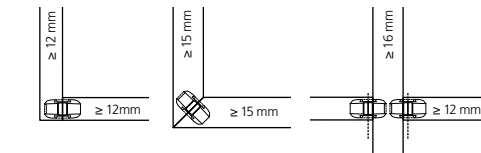

Important: The aligning element Bisco P-10 is ideal to dry-assemble the joints before glueing

Size	52 × 19 × 9.7 mm
Cutter	Ø 100.4 × 7 × Ø 22 mm
Material connector	Fiberglass reinforced plastic
Installation tolerance	Long. ± 1 mm/radial ± 1 mm
Tensile strength (N)	Depending on the adhesive
Material range	Particle board, MDF, plywood, softwood, hardwood etc.

See **PAGE 67** for technical specifications

www.lamello

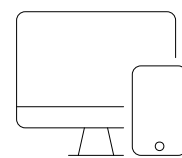

Experience the connector live and receive comprehensive product information!



Application examples

Tenso P

Furniture manufacturing/Interior fitting: Furniture, shelves, stools, sideboards, wardrobes, wall panels, cladding, decorative strips, covering panels, plinths, face frames etc.

Shop fitting/Kitchen manufacturing: Furniture, shelves, stools, sideboards, wardrobes, show cases, sales counters, wall panels, cladding etc.

Tenso P-14



Tenso P-14



Tenso P-10

Tenso P-14



Divario P-18

Self-clamping, invisible connector for slide insertion



Features

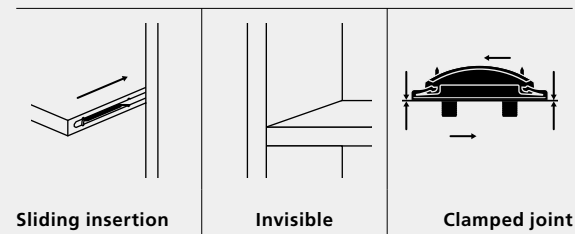

Divario P-18 is a detachable connector for slide-in insertion and is anchored in the form-locking P-System groove within seconds.

The connector is used to slide shelves or partitions into an already assembled cabinet. In the process, the Divario P-18 clamps the workpieces together firmly and ensures perfectly closed joints without visible connectors.

Divario P-18 is used for joining shelves to divisions from 18 mm panel thickness or in butt joints from 12 mm.

Articles



Divario P-18	Art. No.
80 pairs	145550
300 pairs	145560
1000 pairs	145570
2000 pieces, element for P-System groove	145520
2000 pieces, element for drill holes	145540



Divario P-18 Installation tool	Art. No.
For fixing the Divario in the workpiece	125500

www.lamello

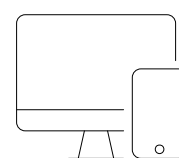

Experience the connector live and receive comprehensive product information!



Function

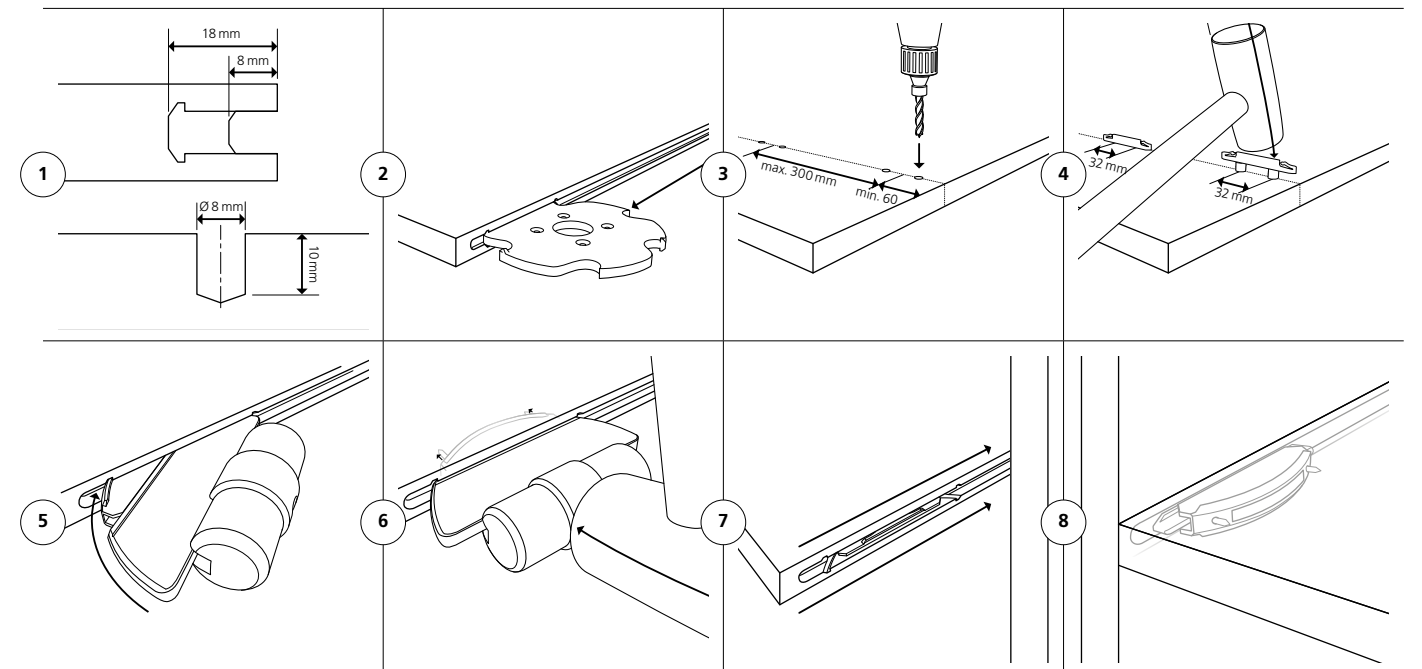

Technical data

Joining methods

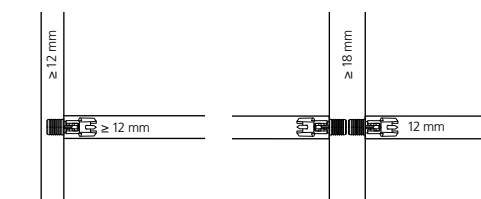

Element with P-System groove	65 × 16 × 9.7 mm
Element with drill holes	Ø 8 × 10 mm, distance 32 mm
Cutter	Ø 100.4 × 7 × Ø 22 mm
Material connector	Fiberglass reinforced plastic
Installation tolerance	Long. ± 1 mm/radial ± 0 mm
Load limits per connector (N) Up to	(mm) 19 22 25 30 MDF 600 ¹ 700 ¹ 800 ¹ 1000 ¹ Particle board 500 ¹ 600 ¹ 700 ¹ 1000 ¹ Beech 1700 ¹ 2000 ¹ 2000 ¹ 2000 ¹ Spruce 800 ¹ 900 ¹ 1300 ¹ 1400 ¹
Tensile strength (N)	All materials 600 ¹
Material range	Particle board, MDF, plywood, softwood, hardwood etc.

See **PAGE 67** for technical specifications | ¹ See comment on load limits on **PAGE 75**

Application examples

Divario P-18

Furniture manufacturing/Interior fitting: Furniture, shelves, open room dividers, wine racks, sideboards, wardrobes, separating walls, showcases, hanging elements etc.



Divario P-18



High performance without cable

LiHD battery pack

Ludwig Bauer, Teamleader Product Management

«With the lightweight, powerful 18 V LiHD 4.0 Ah battery pack, the Zeta P2 cordless is ideally equipped to cut longitudinal grooves for the Divario P-18 – even in solid wood.»



Powerful!
Battery alliance with
over 30 brands

www.cordless-alliance-system.com



LiHD: The world's most powerful battery system in the industry

A unique interplay of:

- Intelligent battery management for long-lasting high capacity
- Patented AIR-COOLED system for short charging times with hot batteries
- High-quality cell structure with 50-percent reduced internal resistance ensures full Zeta power even with a small battery pack

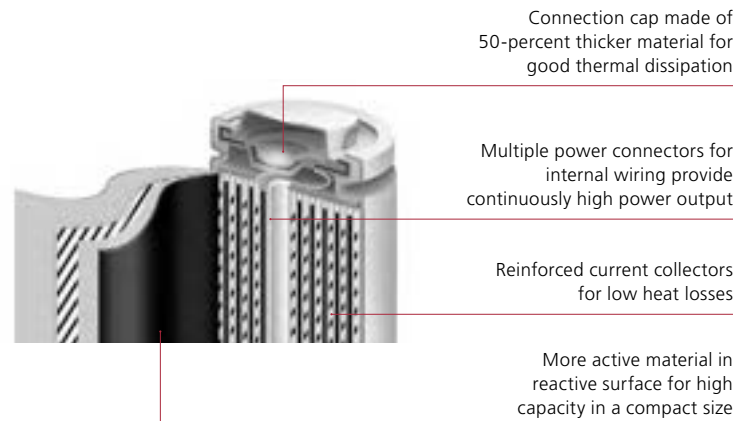

Powerful 18 V LiHD battery pack either as 4.0 Ah or 5.5 Ah

18 V LiHD 4.0 Ah

- Included as standard battery in the set
- Compact, lightweight and powerful
- Suitable for all applications



18 V LiHD 5.5 Ah

- Available as an option for even longer working periods



More flexible in the workshop

The ready-to-hand battery-powered biscuit joiner ensures greater efficiency and flexibility in the workshop.

- No tangling of the cable or the suction hose when machining large workpieces
- Cutting directly on the workpiece reduces the handling of bulky parts. There is also no need to disconnect and plug in the cable

- Quick production of furniture with different angles without complicated programming on the CNC
- Create prototypes without time-consuming machine setup. Unrestricted design freedom thanks to the wide variety of joining elements

- The cordless power tool can be used to easily adapt or add grooves in no time
- Corner connections are quickly and precisely cut directly at the work bench

Large workpieces



Fitted panels



- Easily and flexibly cut grooves in fitted panels on site, even if the furniture has been completely machined on the CNC
- Additional grooves on the longitudinal joint for fillers or pillar cladding are created extremely efficiently after fitting

Exclusive individual pieces



Roof window casing



- For renovation work, the grooves are only cut directly on site after fitting
- Cable-free work facilitates handling overhead and in hard-to-reach niches

Adapting furniture



Terrace floors



- Join components outdoors without access to a power connection
- No walkways between the processing site and the installation site, and no additional handling of the cable reel



Zeta P2 cordless

The powerful P-System biscuit joiner for cordless freedom



Features

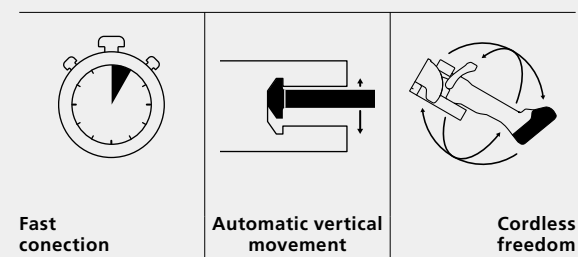

The Zeta P2 cordless is the battery-powered biscuit joiner for even faster joining, suitable for use with P-System connectors. It is used to create the form-locking P-System groove within seconds, and is even more flexible to use due to its cordless freedom. The integrated vertical mechanical drive is automatically triggered at the maximum cutting depth and performs a lateral cutter movement for the P-System groove. Connectors with various functions and different sizes can now be inserted into the form-locking P-System groove without the need for any tools.

Articles



Zeta P2 cordless biscuit joiner, DP (diamond) Art. No.

In systainer, incl. 2 batteries and charger, **101801DESD**
plug type C Euro

In systainer, without batteries, without charger **101800DESD**

In systainer, incl. 2 batteries and charger, **101801GBSD**
plug type G

In systainer, without batteries, without charger **101800GBSD**

For other plug versions please contact your local Lamello specialist



Kit contains

Zeta P2 cordless biscuit joiner, DP, 2 x battery pack 18 V, LiHD 4.0 Ah*, battery charger ASC 55*, P-System drill jig incl. drill, suction stub 36mm, spacer 2 and 4 mm, dust bag, tool set, stop square

** Only included in art. No. 101801DESD/101801GBSD*

www.lamello

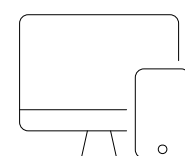

Experience Zeta P2 cordless live and receive comprehensive product information!



Function

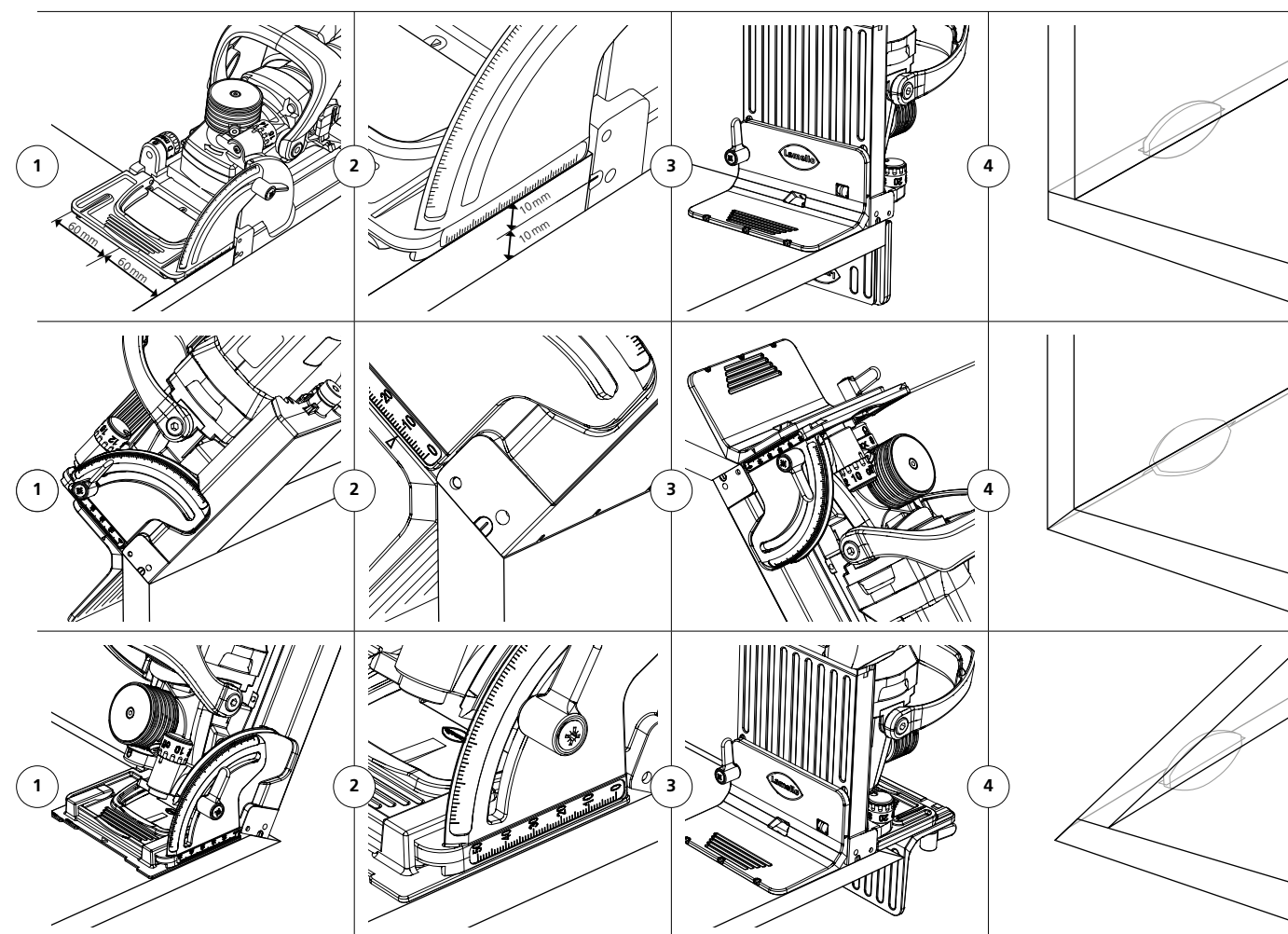

Technical data

Battery voltage	18 V	Groove width	7/10 mm
Speed	9000 min ⁻¹	Groove depth max.	20 mm
P-System Cutter	Ø 100.4 x 7 x 22 mm	Weight	3.7 kg incl. battery

Zeta P2

The machine for the evolving P-System, saving you time daily! Differentiate your products from the standard!



Features

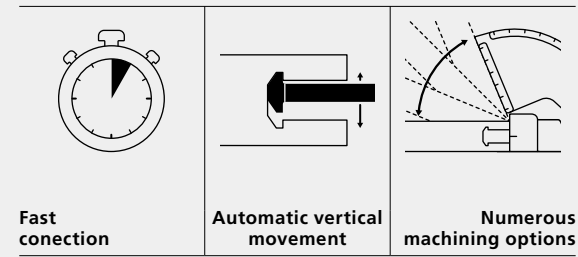

The Zeta P2 is the biscuit joiner for P-System connectors and is used to create the form-locking P-System groove within seconds.

The integrated vertical mechanical drive is automatically triggered at the maximum cutting depth and performs a lateral cutter movement for the P-System groove. Connectors with various functions and different sizes can now be inserted into the form-locking P-System groove. The insertion into the groove is quick and without tools.

Articles



Zeta P2 with P-System

groove cutter HW (carbide)

Art. No.

In systainer³ M, plug type F Schuko **101403DES**

In systainer³ M, plug type G **101403GBS**

In systainer³ M, plug type C Euro **101403CHS**

Zeta P2 with P-System

groove cutter DP (diamond)

Art. No.

In systainer³ M, plug type F Schuko **101403DESD**

In systainer³ M, plug type G **101403GBSD**

In systainer³ M, plug type C Euro **101403CHSD**

For other plug versions please contact your local Lamello specialist



Kit contains

Zeta P2, P-System groove cutter, stop square, suction stub 36 mm, disc for angles, spacer 2 + 4 mm, tools, Clamex P drill jig incl. drill

www.lamello

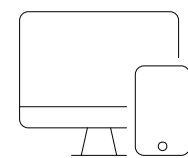

Experience Zeta P2 live and receive comprehensive product information!



Function

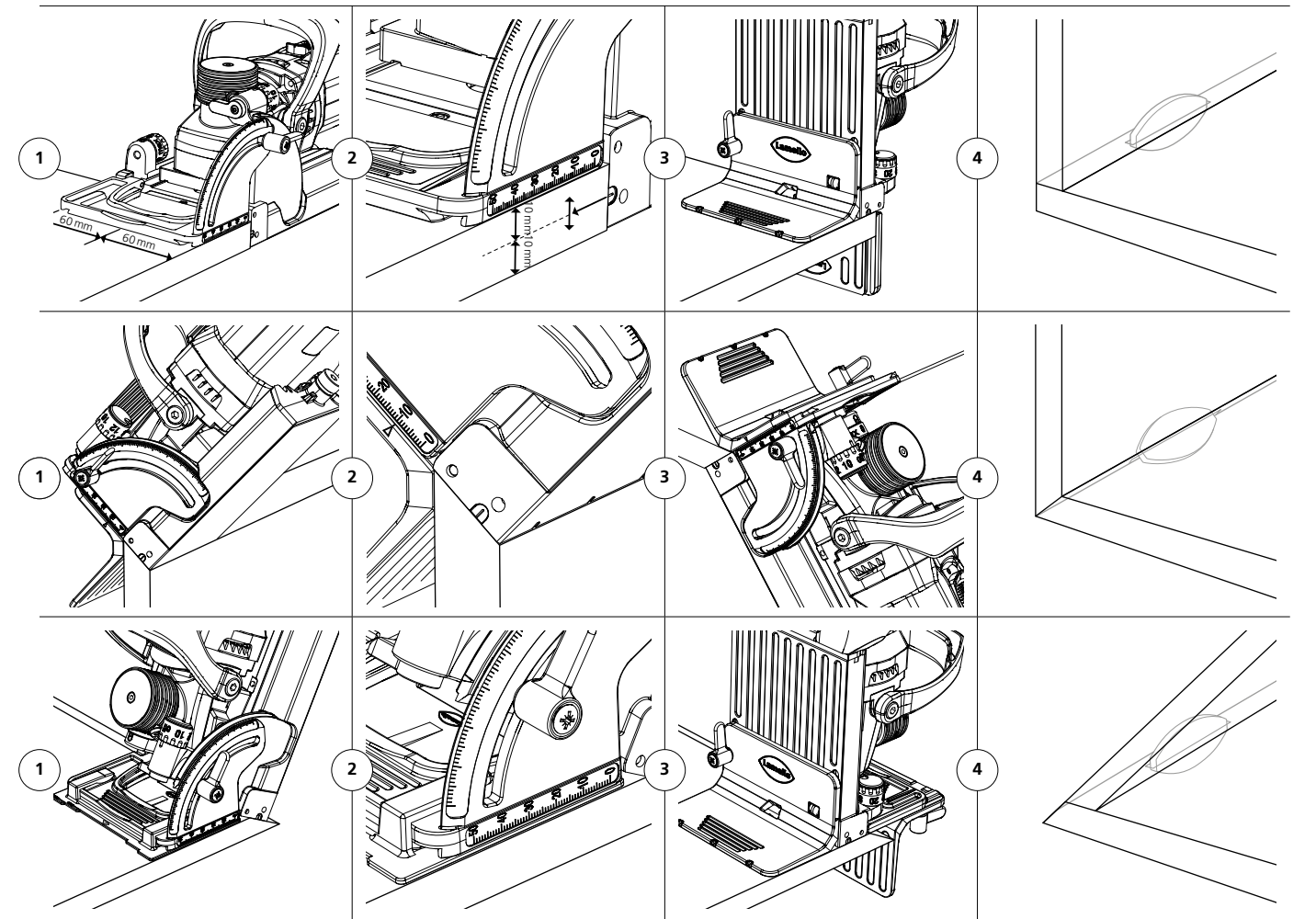

Technical data

Power/Voltage	1 050 W/230 V 800 W/120 V	Teeth	Z3
Speed	9 000 min ⁻¹	Cutting depth max.	20 mm
P-System Cutter	HW: Ø 100.9 × 7 × Ø 22 mm DP: Ø 100.4 × 7 × Ø 22 mm	Weight	3.7 kg

Accessories

Zeta P2 cordless and Zeta P2

Accessories



Stop square for Zeta P2, Top 21, Classic X Art. No. **251044**
For stabilising the biscuit joiner in the vertical position, ideal for obtuse mitre joints



Spacer for Zeta P2, Top 21, Classic X Art. No. **253027**
5 mm, aluminium for 18 mm panels
253023
2 mm, plastic for 16 mm panels
253026
4 mm, plastic for mitres



P-System groove cutter DP (diamond),
Ø 100.4 × 7 × Ø 22 mm Art. No. **132140**
Z3, 4 NL for Zeta P2



P-System groove cutter HW (carbide),
Ø 100.9 × 7 × Ø 22 mm Art. No. **132141**
Z3, 4 NL for Zeta P2



Groove cutter HW (carbide),
Ø 100 × 4 × Ø 22 mm Art. No. **132000**
Z2 + V4 scoring teeth, 4 screw holes, hub
for Zeta P2/Top 21/Classic X



Dust bag Art. No. **257532**
For Zeta P2/Top 21/Classic X

Batteries



Art. No. **313013**
Battery pack 18 V, LiHD 4.0 Ah



Art. No. **313015**
Battery pack 18 V, LiHD 5.5 Ah



Art. No. **123100**
Battery charger ASC 55

Connected in seconds ...

Without waiting time, clamps, or secondary processes,
glued and clamped in 40 seconds

Advantage

... with Clamex P – detachable

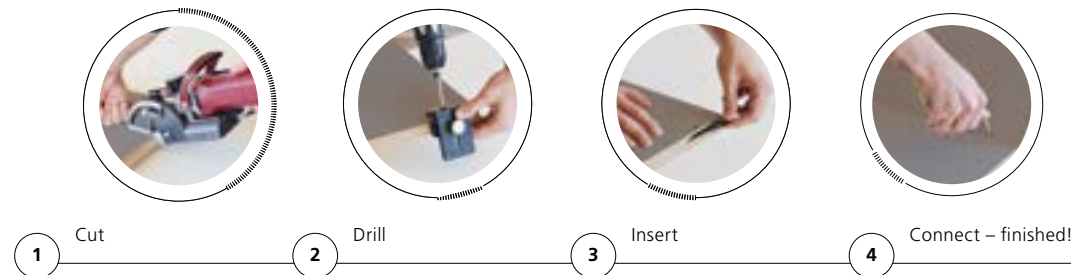

Time for one connector pair

1. Cut	25
2. Drill	15
3. Insert	5
4. Connect – finished!	5

Ready in 50 s

... with Tenso P – glued

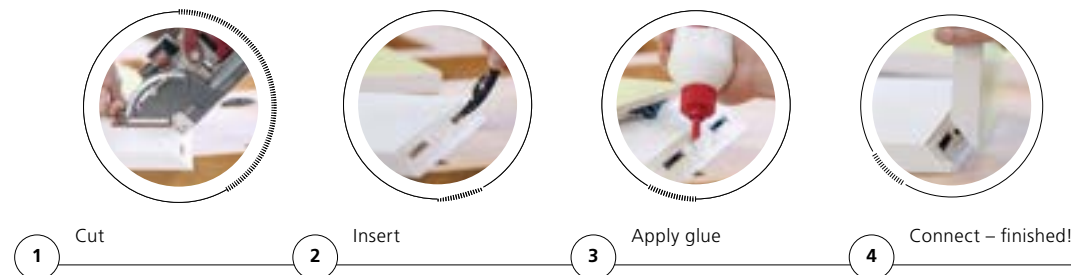

Time for one connector pair

1. Cut	25
2. Insert	5
3. Apply glue	5
4. Connect – finished!	5

Ready in 40 s



Versatile use with many different connecting elements.

With the Zeta P2, you can quickly and easily connect parts with a range of angles and joining situations. Suitable for individual pieces of furniture as well as prototypes and line production.



With P-System groove

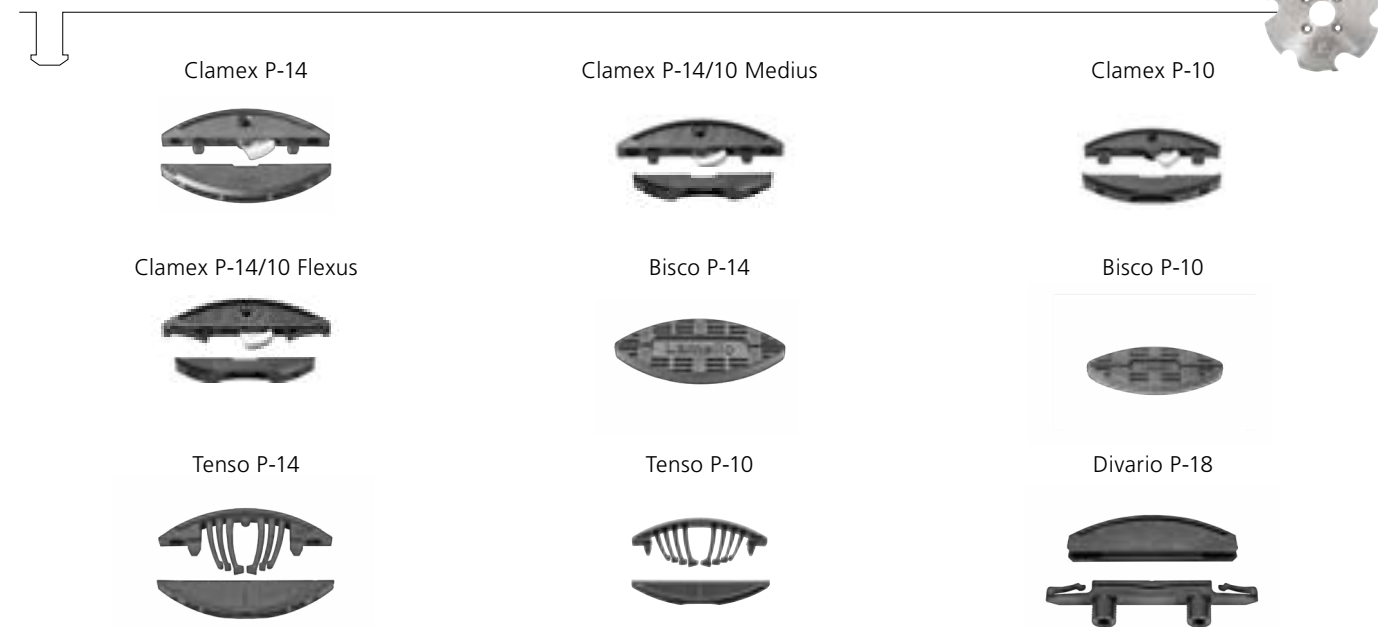

With 4 mm Lamello System groove cutter



With 3 mm Lamello System groove cutter



P-System depth adjustment

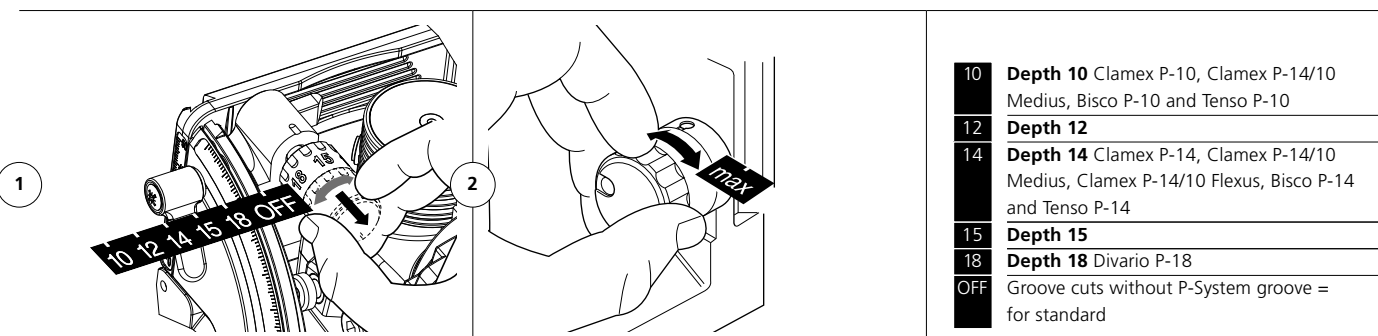

Lamello depth adjustment system

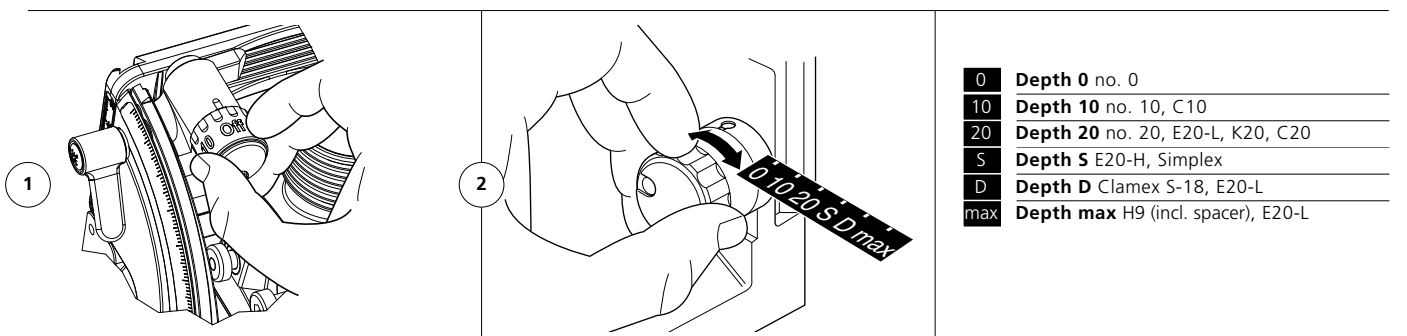

Changing the cutter position

Using spacers

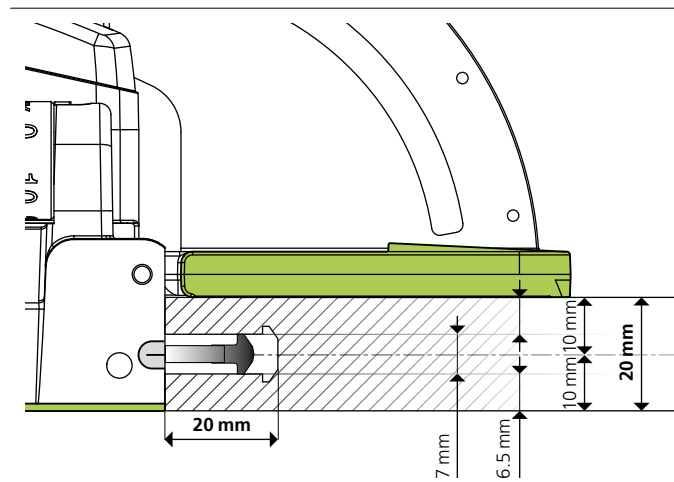

- ➔ The underside of the **base plate** and the **swivelling front** are reference surfaces with which the Zeta P2 is positioned on a work piece.
- ➔ The position of the **cutter** lies precisely in the centre between these two surfaces, so that the distance from the centre of the cutter to the edge will always be 10 mm.
- ➔ This distance can be altered by using a **spacer** clipped to the swivelling front.

Without spacer

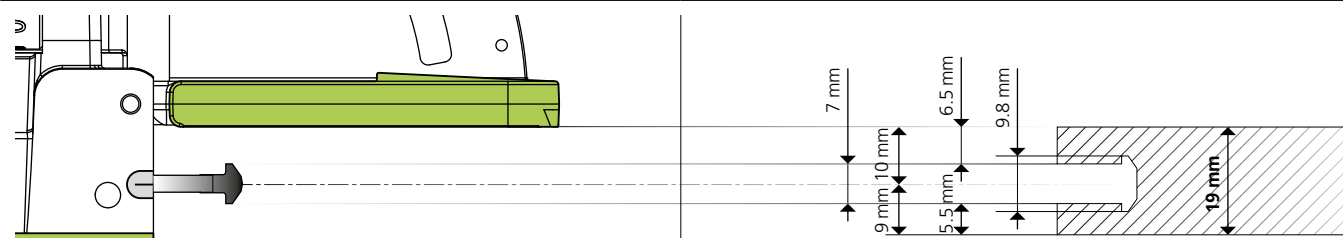

With spacer

With 2 mm spacer used in 16 mm material thickness

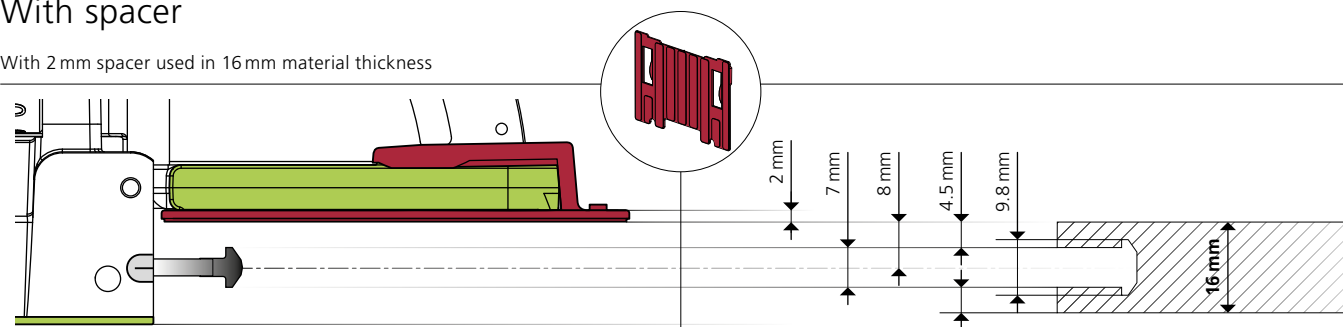

With 4 mm spacer used in 12 mm material thickness

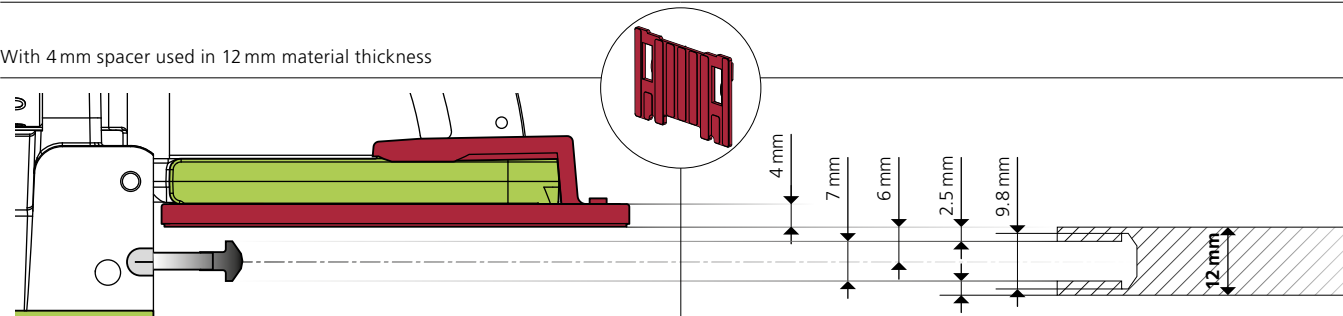

Joints in various angles

P-System grooves on edges cut to an angle



To create **joints in various angles**, at least one of the two workpieces needs to have one of its edges cut to an angle. There are **two possibilities** to cut a groove into an edge: Applying the Zeta P2 either on the outer side or the inner side of the work piece as the reference surface.

A. Positioning the Zeta P2 on the **face** of the workpiece:

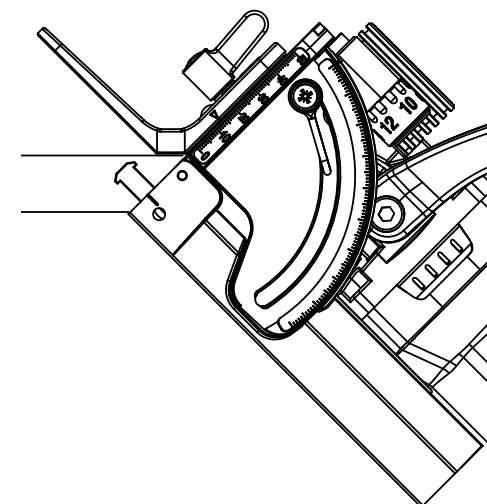

Using this method, the **multifunctional stop square is attached to the swivelling front and fixed at the desired position.**

The machine is then applied on the work piece in such a manner, that the stop square rests on the outer side (green surface) of the workpiece.

Advantages

- Perfectly flush on the visible work piece outer side. Material tolerances cannot lead to misalignment with this method
- Steplessly adjustable stop square, allowing for perfect positioning of the groove in every board thickness
- Thick work pieces with two rows of grooves (see picture above) with varying groove positions to increase strength
- No mistakes due to sliding during cutting because the machine sits very tightly in its position

Only angles 45° oder 67.5° are possible with this method



B. Positioning the Zeta P2 on the **inner side** of the workpiece:

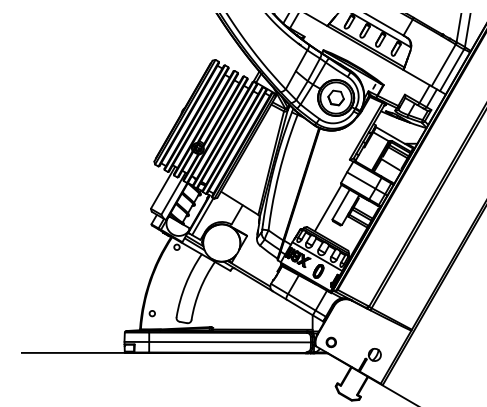

Using this method, the **swivelling front is adjusted to the angle of the workpieces edge and then fixed in that position.**

The machine now lies on the inner side (green surface) of the work piece, due to which material tolerances can show on the outer side of the workpieces.

Advantages

- The groove position is fixed, however, to two more positions are available using the 2 mm or 4 mm spacers
- The advantage of this method is that all angles from 0-180 degrees are possible

Networked production

From planning and design to procurement, programming and machining with CNC.

Our planning and processing partners support you with integrating Lamello connecting elements into your production process, from A to Z.

CAD/ERP/CAM software



CNC machines/Aggregates/CNC tools



Components for the successful integration of Lamello connection systems into your networked production

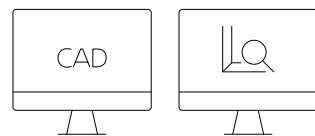

CAD/ERP/Configurator software

- Design and planning software with integrated Lamello connectors
- Also download CAD data:
 - from the Lamello website
 - from iFurn
 - from specialist retailers (ComNorm)

The degree of integration of the data and the parameterised position rules influence planning efficiency.

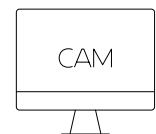

CAM software

- Software for generating CNC programming data
- Post-processor

Data transfer between CAD and CNC, and in particular the control of the macros/component, must be individually coordinated.

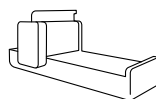

CNC machine

- Machine with 3/4/5-axis

The number of axes and equipment options influence the processing possibilities

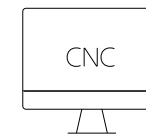

CNC software

- Purchase software for machine/macro/component from the manufacturer or
- Program the machining process yourself

The macro/component determines/affects the processing possibilities

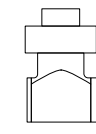

Suitable aggregate

- Aggregate sub-program
- The angle aggregate makes it easier to cut the P-System groove in the surface and the centre of the surface

The right unit can significantly increase efficiency when cutting connectors.

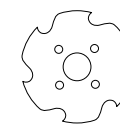

- Purchase tools from Lamello or a P-System tool partner
- You can find the tools recommended by Lamello on **PAGES 62-63**.

The right cutting tool can significantly increase precision and efficiency when cutting the connectors

Service overview

Lamello's planning and machining partners



Machining partners CNC machines/Aggregates/CNC tools

Company	AES	Biesse	Felder	GANNOMAT	HOLZ-HER	Holzfraese	Homag	KOMO	IMA	INFOTEC	Masterwood	SCM, Morbidelli	Vitap	Atemag	Benz Tools	GROTHEFELD	HSD	Leitz	Leuco	Oertli	Utensiltecnica	
Product name	CNC machines AesWOP	CNC machines bSolid NC Hops bCabinet	CNC machines F4Integrate Wood Flash	CNC machines GANNOMAT Editor CNC machines	NC Hops CabinetControl NEO 3D-Master	CNC machines SmartWOP Machine CNC WoodWOP cabinetCreator		CNC machines	CNC machines IMAWOP	CNC machines	CNC machines Masterwork/Master 3D	CNC machines Maestro CNC Xylog Plus	CNC machines Software TPA	Various	Various	Various	Various	Various	Various	Various	Various	Various
Offer / Material management / Ordering	ERP software Interface with procurement Interface with CAD																					
Visualisation / Planning / Construction / Parts list	Interface with ERP Data cloud for CAD data CAD 2D software CAD 3D software Configurator																					
CNC programming data	Interface with CNC CAD/CAM software WOP programming software ISO programming software																					
CNC machining	CNC with consoles CNC vertical/horizontal (compact) CNC nesting Aggregates CNC tools																					

P-System with CNC

Joining methods and requirements for
CNC machines/machining options



CNC machines		With consoles/ vertical or horizontal					With nesting technology					
Number of axes		3			4	5	3			5		
			Machining option	Machining option			Machining option		Machining option			
Joining methods	Machining											
	Access drill hole											
	Profile groove in the edge											
	Profile groove on the surface (close to the edge)											
	Profile groove on the surface (centre of the surface)*											
	Access drill hole 45°											
	Access drill hole 45°											
	Access drill hole 22 – 108°											
	Access drill hole 22 – 108°											

Additional explanations for the requirements of the CNC machines/machining options



Detailed information on machining	Detailed information on machining	Possible setup of aggregates and tools	Comments	
			Integrated CNC Z-axis with drill (5/6 mm) or with collet chuck for clamping Ø 10 mm and drill 131556	P-System CNC drill bit on PAGE 62
			Saw blade clamp Ø 40/DTK 52 mm and cutter 132143 or with collet chuck and cutter arbor	You can find dimensions for cutters and clamping Ø and lengths of cutter arbors on PAGE 62/63
			Angle aggregate – One to four spindle angle aggregates – Floating trimming unit for P-System – Corner notching aggregate – Aggregate for door locks	A unit overview can be found on the Lamello website: www.lamello.com under planning and machining partners
			Manually adjustable swivelling aggregates Information: Several tool changes required for angle cuts, drilling and P-System grooves	Note: The cutting depth in the centre of the surface may be restricted depending on the model. Tip: For a mitre, the drill hole could be made with the manual drill
			Automatically adjustable swivelling aggregates with automatic tool changer (FLEX5+C/5-MOTION PLUS/Flex5+C, from year of manufacture 2015) – Tool holder WFC 40-25 clamping Ø 10 mm for drill – Drill shaft Ø 10 mm, tool protrusion max. 50 mm – Tool holder WFC 40-25 with flange and cutter 132143	Note: In the centre of the surface, the profile groove depth is limited to 10 mm
			Shrink chuck for clamping Ø 12 x 40 mm and shaft tool 131342 or collet chuck for clamping Ø 12 x 40 mm and shaft tool 131342	P-System CNC shaft tool cutter on PAGE 63 .

* More information on **PAGES 62–63**

The information concerns technical options regarding how the applications could be implemented. These must be adapted to your company facilities and coordinated with the planning and machining partners.

Possible combination of CNC machines with Zeta P2

More regarding the machining on **PAGE 61**

--	--	--	--

P-System equipment options

For CNC machines for particularly efficient machining

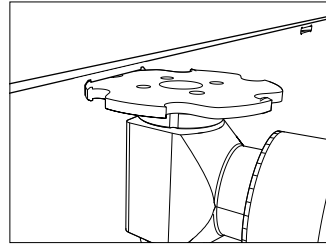
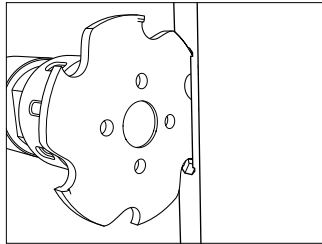

Vertical and horizontal CNC machining centres «CNC compact class»



HOMAG

DRILLTEQ V-500
25-spindle +
1x aggregate (VKNR 1549)
1x tool set (VKNR 9763)

1 · 2 · 3



**EVOLUTION 7405
Connect**

1 · 2 · 3



BIESSE

Brema Eko 2.1
1x aggregate
2x P-System CNC
groove cutters
1x P-System CNC cutter arbor
1x drill Ø 6 mm

1 · 2 · 3



BIESSE

Brema Eko 2.2
1x aggregate for 90°
1x aggregate 45° for 2x 45°
2x P-System CNC
groove cutters
1x P-System CNC cutter arbor
1x drill Ø 6 mm

1 · 2 · 3 · 4



Project TF 100/TF 100 2.0
1x aggregate
2x P-System CNC
groove cutters
1x P-System CNC cutter arbor
1x drill Ø 6 mm

1 · 2 · 3



cx 210
1x aggregate
2x P-System CNC
groove cutters
1x P-System CNC cutter arbor
1x drill Ø 6 mm

1 · 2 · 3



Nextec 7707
1x tool set

1 · 2 · 3



Vitap K2 2.0
1x aggregate
2x P-System CNC
groove cutters
1x P-System CNC cutter arbor
1x drill Ø 6 mm

1 · 2 · 3

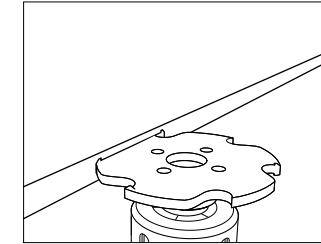
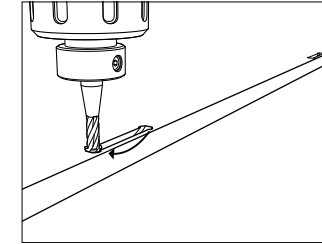

FORMAT

Creator 950
1x P-System CNC
groove cutter in HSK63F
1x P-System CNC shaft tool
cutter* in HSK63F
1x drill Ø 6 mm

*optional for P-System CNC
shaft tool cutter:
1x aggregate for 90°
1x P-System CNC groove cutter

1 · 2 · 3



GANNOMat

**ProTec + P-System
add-on package**
Editor with
Lamello P-System macro
1x P-System CNC
groove cutter in HSK63F
1x P-System CNC cutter arbor
1x P-System CNC shaft tool
cutter
1x drill Ø 6 mm

1 · 2 · 3



HOMAG

DRILLTEQ V-200
woodWOP «Lamello P-System»
component
1x P-System tool set

1 · 2 · 3

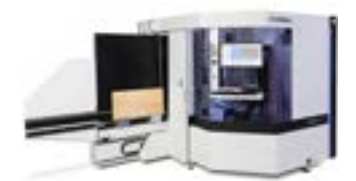

HOMAG

DRILLTEQ V-310
for 180° + 90° joints:
woodWOP component
«Lamello P-System»
1x P-System tool set

additionally for
45° joints:
2x aggregate 45°
1x tool set for 45°

1 · 2 · 3 · 4

Connectivity

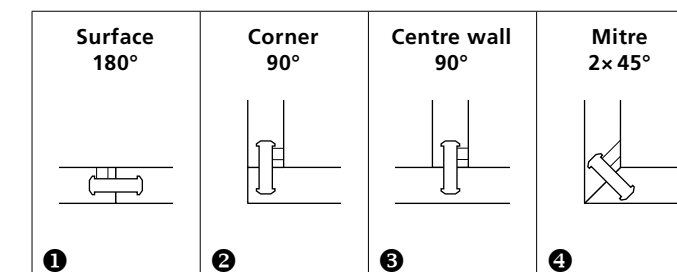

www.lamello

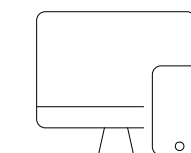

Experience CNC live and
receive comprehensive
product information!



Ideas for standardising

The machining on a CNC machine

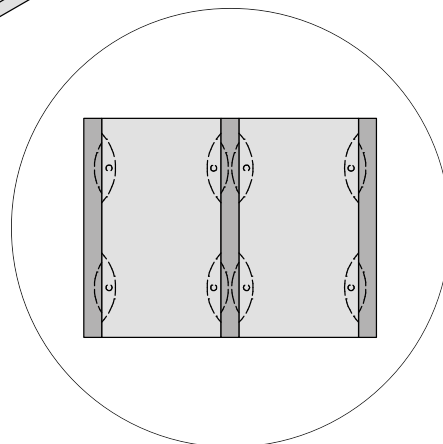
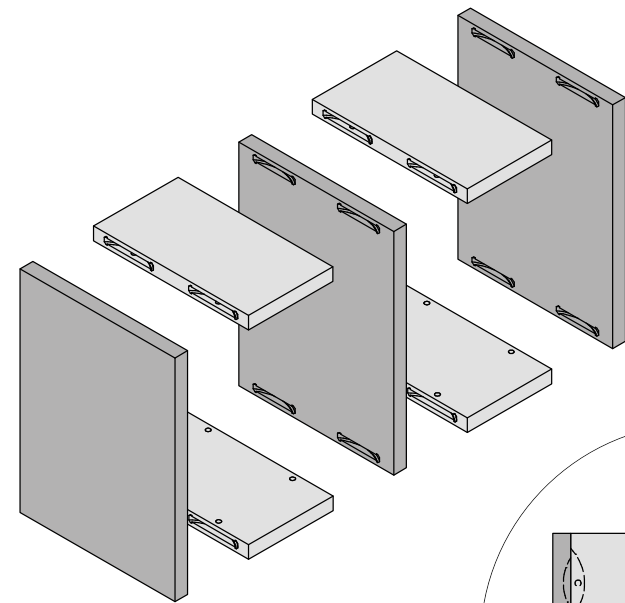

Clamex P-14 CNC with lever, Clamex P-14 with lever and Clamex P-14/10 Flexus with lever are compatible with all Clamex P elements without lever.
This allows for a standardised construction method.

Depth 14 mm for all P-System grooves
in the panel edge (with the access hole)

	Art. No.
2000 pieces element with lever	145388

	Art. No.
2000 pieces element with lever	145338

	Art. No.
2000 pieces element with lever	145318

Depth 10 mm for all P-System grooves
in the surface

	Art. No.
2000 pieces element without lever	145358

	Art. No.
2000 pieces element without lever	145369

Possible combination of CNC machines with Zeta P2

Precise drilling on a CNC machine; use these drill holes to position the Zeta P2 to cut the P-System grooves.
This application is especially ideal if the CNC machine is a nesting machine and or no aggregate is available.
This method combines the precision and efficiency of a CNC machine and uses the simple and fast machining of a P-System groove with a Zeta P2.

Positioning drill holes for the Zeta P2

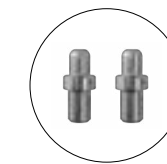
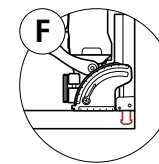

Positioning pin CNC for Zeta P2,

2 pieces	Art. No.
Ø 5 mm	251048
Ø 8 mm	251066

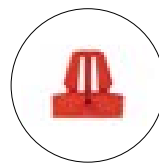
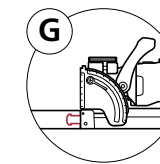

Positioning clip CNC

for Zeta P2	Art. No.
Ø 6 mm	251067
for positioning in the Clamex P access hole (6 mm)	

Machining steps

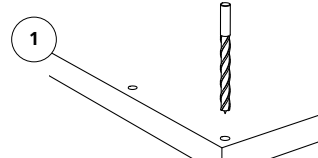
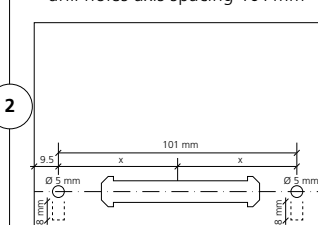
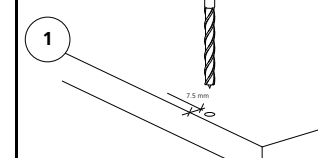
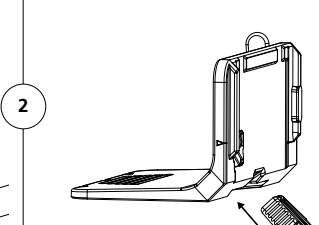
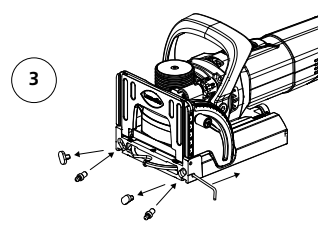
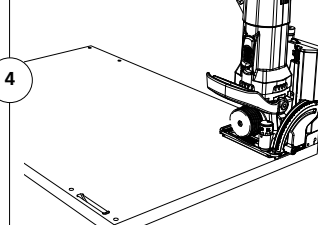
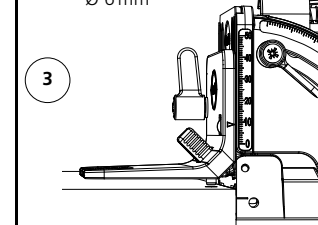
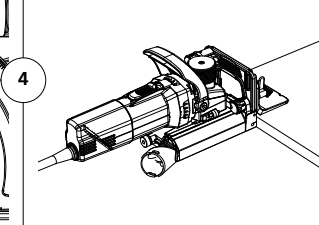
<p>1. Drill the positioning holes with the CNC, Ø 5 mm/Ø 8 mm</p> 	<p>2. Hole pattern of the positioning drill holes axis spacing 101 mm</p> 	<p>1. Drill the positioning hole with the CNC, Ø 6 mm</p> 	<p>2. Insert the positioning clip</p> 
<p>3. Insert the positioning pins in the Zeta P2</p> 	<p>4. Position the machine in the drill holes</p> 	<p>3. Insert the positioning clip in the drill hole Ø 6 mm</p> 	<p>4. Cut the groove with the positioned machine</p> 

CNC tools

For the P-System



P-System CNC tools



P-System CNC drill bit Art. No. **131556**
6 mm, solid carbide, for mitres,
L = 100/35 mm, shaft = Ø 10 mm



**P-System groove cutter CNC DP (diamond),
Ø 100.4 x 7 mm** Art. No. **132142**
Ø 100.4 x 7 x Ø 30 mm, Z3, NL 4 x Ø 6.6 x Ø 48 mm
suitable for all P-System CNC cutter arbor listed
on the right
Ø 100.4 x 7 x Ø 30 mm, Z3, NL 4 x Ø 6.6 x Ø 48 mm **132149**
LH for Weeke BHX 200 / DRILLTEQ V-500
(left hand rotation)



Art. No. **132145**
Ø 100.4 x 7 x Ø 30 mm, Z6, NL 4 x Ø 6.6 x Ø 48 mm
suitable for all P-System CNC cutter arbor listed
on the right



Art. No. **132143**
Ø 100.4 x 7 x Ø 40 mm, Z3, NL 4 x Ø 5.5 x Ø 52 mm
E.g. for angle aggregates and FLEX5+C/
5-MOTION PLUS



Art. No. **132144**
Ø 100.4 x 7 x Ø 16 mm, Z3, NL 4 x Ø 5.5 x Ø 28 mm
E.g. for corner notching aggregate



Art. No. **132148**
Ø 100.4 x 7 x Ø 35 mm, Z3, NL 4 x Ø 5.5 x Ø 50 mm
e.g. for Brema Eko 2.1, Masterwood Project TF 100,
Format4 D-Jet
Ø 100.4 x 7 x Ø 35 mm, Z3, NL 4 x Ø 5.5 x Ø 50 mm **132180**
LL e.g. for Format4 Nesting profit H08
(left hand rotation)



**CNC cutter arbors for P-System groove
cutter, Ø 30, NL 4 x M4 x Ø 48 mm** Art. No. **132150**
Shaft Ø 20 x 50 mm, L = 102 mm



Art. No. **132151**
Shaft Ø 25 x 60 mm, L = 102 mm



Art. No. **132152**
Shaft Ø 16 x 50 mm, L = 85 mm



Art. No. **132153**
Shaft Ø 16 x 55 mm, L = 68 mm



Art. No. **132154**
Shaft Ø 16 x 50 mm, L = 85 mm, with clamping
surface (2°- angle) e.g. for aggregate for door locks



Art. No. **132155**
Shaft Ø 20 x 50 mm, L = 85 mm,
with clamping surface (2°- angle)
e.g. for aggregate for door locks

132159
M6 x 16 mm Torx countersunk bolt, 4 pieces,
suitable for cutter arbors
271919
Screwdriver with cross-grip, Torx T20 x 100 mm



P-System CNC shaft tool cutter Art. No. **131342**
HW solid (carbide), shaft Ø 12 x 40 mm, L = 80 mm

One tool with 2 functions

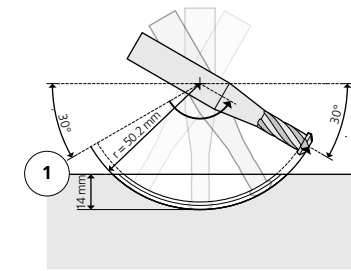

**P-System CNC
shaft tool cutter
with 5-axis**

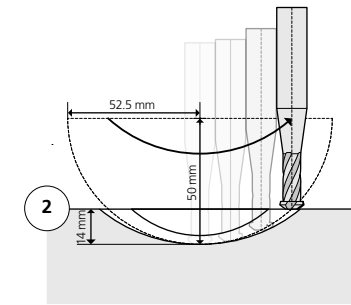

**P-System CNC
shaft tool cutter
with 3-axis**

**Lamello recommends making all profile
grooves with a disc cutter, primarily for
reasons of precision, service life, machining
time and thus economic efficiency.**

A P-System CNC shaft tool cutter or contour cutter should
only be used for the machining of surfaces if no angle
aggregate is available.

Technical information

Overview of connectors + grooves (scale 1:1)

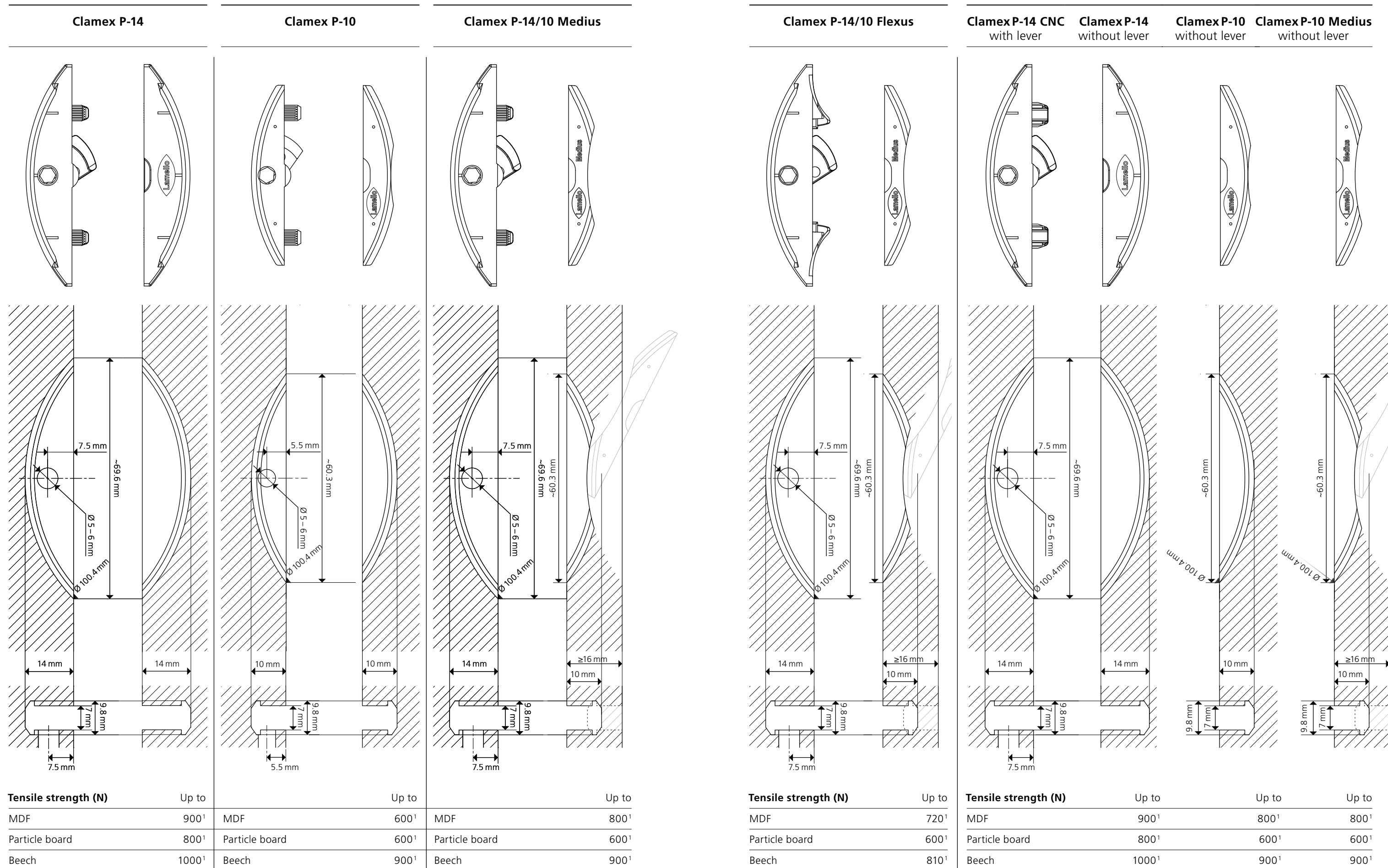

Technical information

Overview of connectors + grooves (scale 1:1)

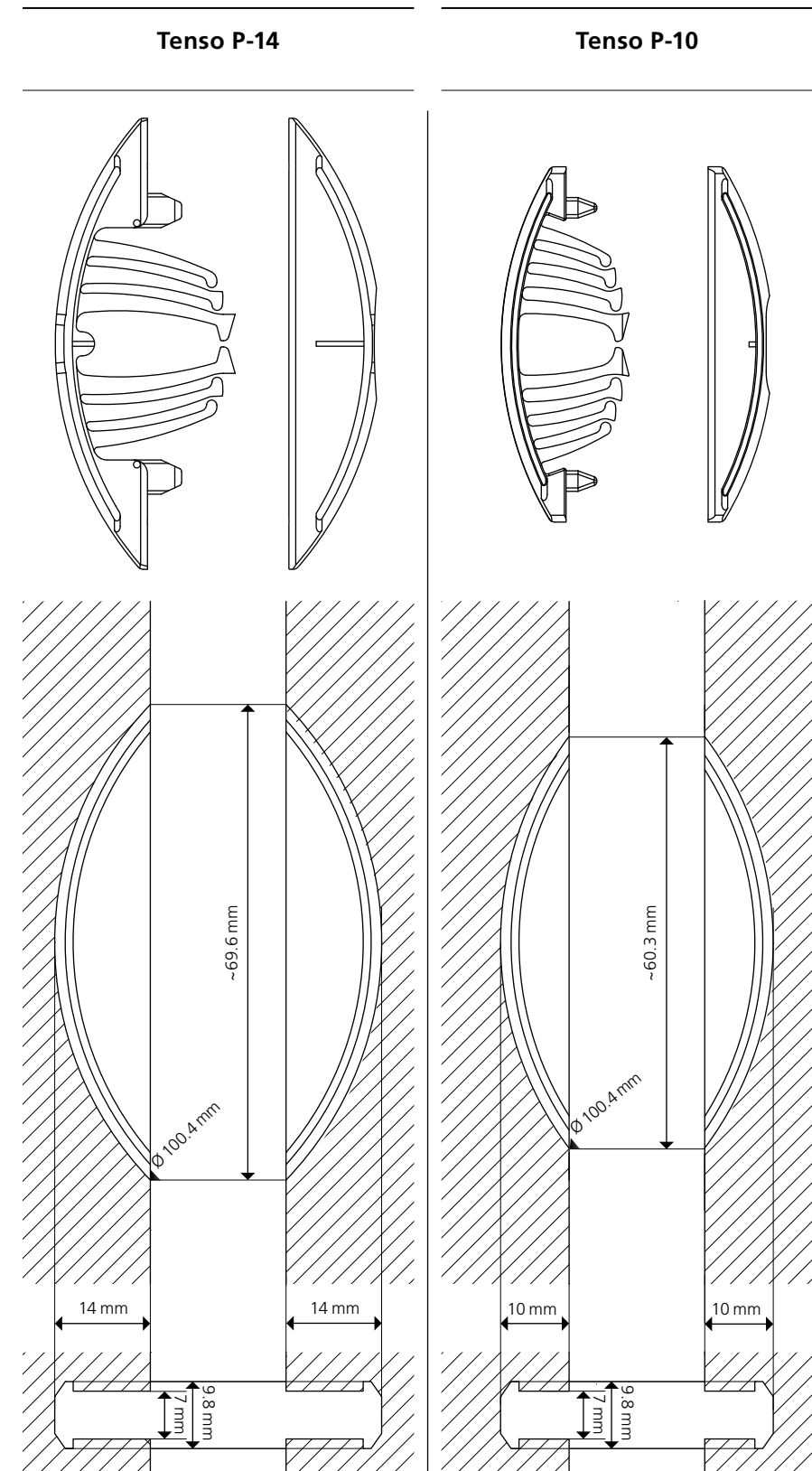
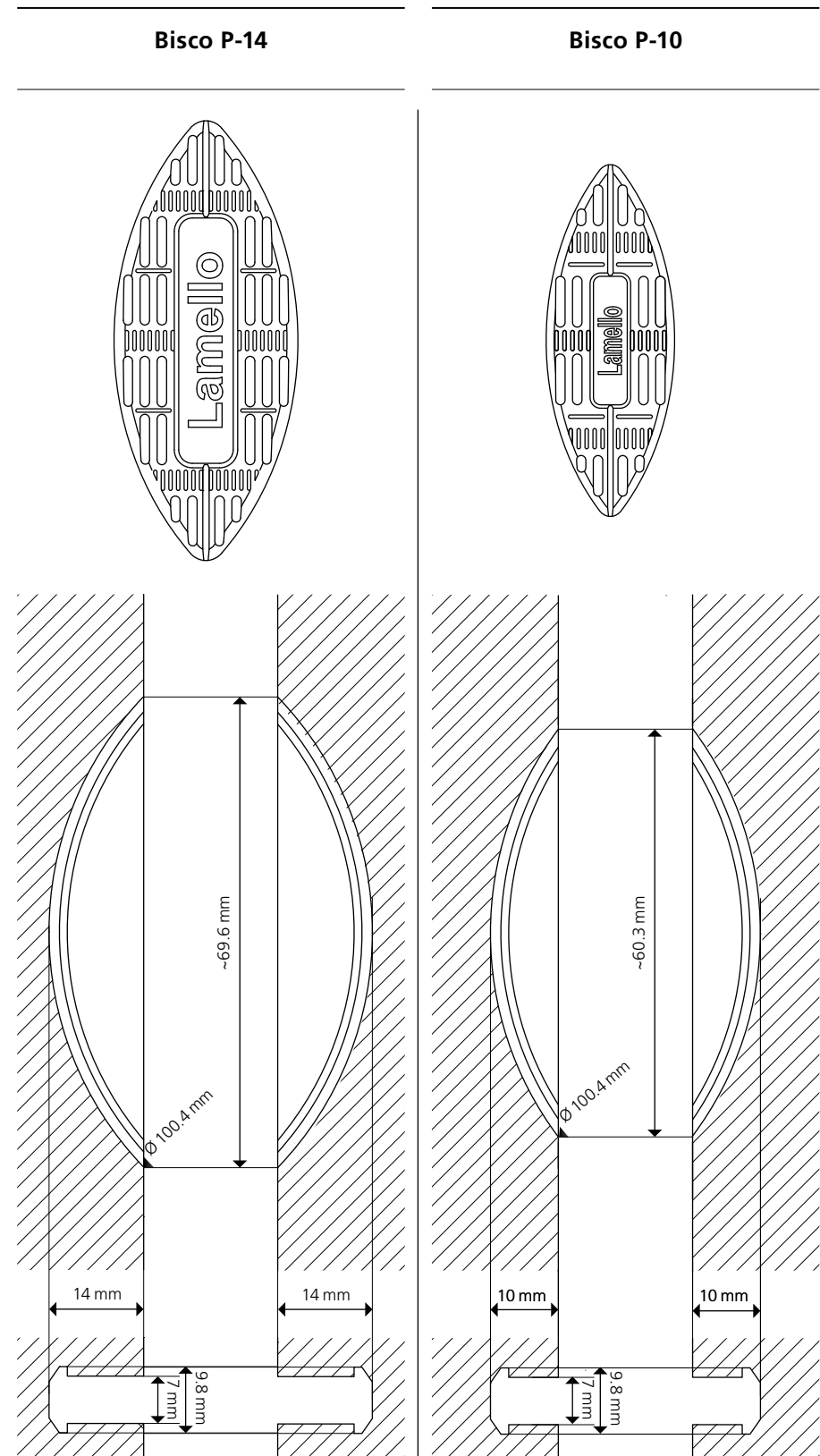

Tensile strength (N)

Depending on the adhesive

Depending on the adhesive

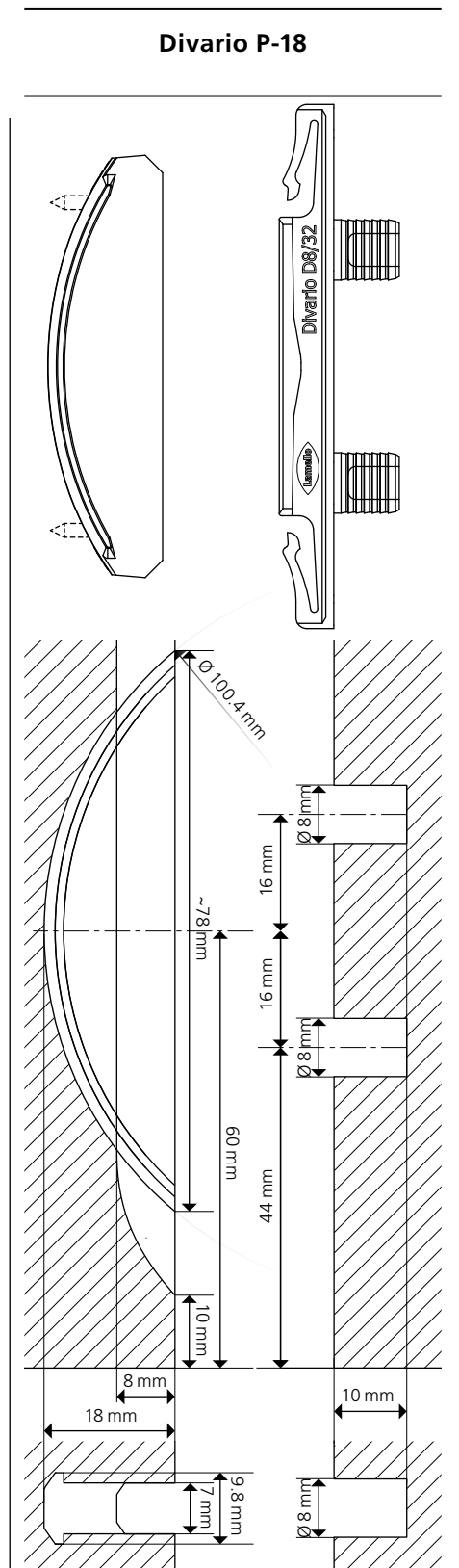

Load limits per connector (N)*

(mm)	19	22	25	30
MDF	600 ¹	700 ¹	800 ¹	1000 ¹
Particle board	500 ¹	600 ¹	700 ¹	1000 ¹
Beech	1700 ¹	2000 ¹	2000 ¹	2000 ¹
Spruce	800 ¹	900 ¹	1300 ¹	1400 ¹

Tensile strength (N)

All materials 600¹

Accessories / Spare Parts

P-System

P-System



P-System connector assortment

professional

Art. No.

Scope of delivery: 120 pairs Clamex P-14, **145323**
30 pairs Clamex P-14/10 Flexus, 30 pairs Clamex P-10,
120 pairs Tenso P-14 incl. preload clip, 30 pairs Tenso P-10
incl. preload clip, 20 pieces Bisco P-14, 20 pieces Bisco P-10,
80 pairs Divario P-18, Divario installation tool/drill/
marking gauge, Clamex P installation tool, Tenso P-14/10
preload tool, Sortainer T-loc



P-System connector assortment

basic

Art. No.

Scope of delivery: 80 pairs Clamex P-14, **145314**
80 pairs Tenso P-14 incl. preload clip,
30 pairs Clamex P14/10 Flexus, 30 pairs Clamex P-14/10
Medius, 20 pieces Bisco P-14, Tenso P-14/10 preload tool,
Systainer II T-Loc incl. compartment dividers

Clamex P



Clamex P assembly tool

Art. No.

For all angles, fast and flexible, hex 4 x 30 mm,
length 290 mm

251993



Allen key

Art. No.

4 mm, 75 x 55 mm

271945

4 mm, 120 x 50 mm

271945A



Cover cap, 100 pieces, 90°

Art. No.

RAL 9010 pure white



335280

RAL 9011 graphite black



335281

RAL 1014 ivory, pine



335282

RAL 1011 brown beige, beech



335283

RAL 8007 fawn brown



335284

RAL 8017 chocolate brown



335289

RAL 9002 grey white



335285

RAL 7035 light grey



335286

RAL 7040 window grey



335287

RAL 7031 blue grey



335288

RAL 7022 umbra grey



335298

Cover cap, 500 pieces, 90°

Art. No.

RAL 9010 pure white



335362

RAL 9011 graphite black



335363

RAL 1014 ivory, pine



335364

RAL 1011 brown beige, beech



335365



Cover cap, 100 pieces, 45°

Art. No.

RAL 9010 pure white



335380

RAL 9011 graphite black



335381

RAL 1014 ivory, pine



335382

RAL 1011 brown beige, beech



335383

RAL 8017 chocolate brown



335384

RAL 7035 light grey



335386

RAL 7022 umbra grey



335388



Clamex P drill jig

Art. No.

Incl. drill, from 22.5° for all

125344

Clamex P connectors (P-10, P-14)

Angle for drill jig

255250

Element insert for size P-10

255251

Element insert for size P-14

255252



Clamex P drill jig long

Art. No.

Drill jig for thick workpieces 100 mm,
(P-14), incl. drill

125345



Drill

Art. No.

Spiral drill Ø 6 mm with centering point,
for Clamex P drill jig

131506

Spiral drill Ø 6 mm with centering point,
for Clamex P drill jig long

131508

Depth adjuster for drill, 6 mm diameter

255243

Accessories / Spare Parts

P-System



Combination CNC and Zeta P2



Positioning pin CNC for Zeta P2*,

2 pieces

Art. No.

Ø 5 mm

251048

Ø 8 mm

251066



Positioning clip CNC for Zeta P2*

Art. No.

Ø 6 mm

251067

for positioning in the Clamex P access hole (6 mm)

Tenso P



Tenso P-14/10 preload tool

Art. No.

Tool to pre-load the Tenso P

145400



P-System 4 mm depth

adjuster attachment for P-8

Art. No.

For offset installation on dividing panels

145439

16 mm with Tenso P-10

Divario P



Divario P-18 Marking jig metal with marking points

Art. No.

Marking jig incl. drill with centering point and

125510

rotating depth collar for the precise drilling of

Divario drill holes by hand



Divario P-18 Marking jig plastic, to mark with a pencil

Art. No.

Marking jig to mark the Divario holes

125511

with a pencil



Divario P-18 Installation tool

Art. No.

Divario P-18 Installation tool for fixing

125500

the Divario in the workpiece



Divario P-18 Starter set

Art. No.

In systainer3 M137, scope of delivery:

145552

Divario P-18, 80 pairs, drill, marking jig in metal

and installation tool

Zeta P2



Stop square for

Zeta P2, Top 21, Classic X

Art. No.

For stabilising the biscuit joiner in the

251044

vertical position, ideal for obtuse mitre joints



Spacer for Zeta P2, Top 21, Classic X

Art. No.

5 mm, aluminium for 18 mm panels

253027

2 mm, plastic for 16 mm panels

253023

4 mm, plastic for mitres

253026



P-System groove cutter DP (diamond),

Ø 100.4 x 7 x Ø 22 mm

Art. No.

Z3, 4 NL for Zeta P2

132140



P-System groove cutter HW (carbide),

Ø 100.9 x 7 x Ø 22 mm

Art. No.

Z3, 4 NL for Zeta P2

132141



Dust bag

Art. No.

For Zeta P2/Top 21/Classic X

257532

Batteries



Art. No.

Battery pack 18 V, LiHD 4.0 Ah

313013



Art. No.

Battery pack 18 V, LiHD 5.5 Ah

313015



Art. No.

Battery charger ASC 55

123100DE

We are here for you!

Support in person

Do you have any questions concerning our products or a certain application? Would you like to learn more about the process benefits for your business? Our qualified employees and sales partners will be happy to help you quickly and competently, whether by telephone, online or during a personal support on site.

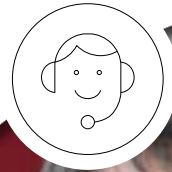

Latest news

Stay up-to-date and sign up for our Lamello News and e-newsletter. Become part of the Lamello community on social media and be inspired, or visit our stand at one of the numerous trade fairs. We are always happy to hear from you.



Our services

Quality is one of the cornerstones of our business, and so our products are designed to last. If a repair is necessary, we can offer you uncomplicated service through our certified Lamello service partners and a spare parts warranty of at least 10 years.



Support in your planning

With the connector search and the P-System configurator on our website, you can quickly find the right connector for your design and requirements. With CAD data for our connectors, tips and tricks, as well as videos about the wide range of applications, we can guide and support you in your planning on our website and on the Lamello YouTube channel.

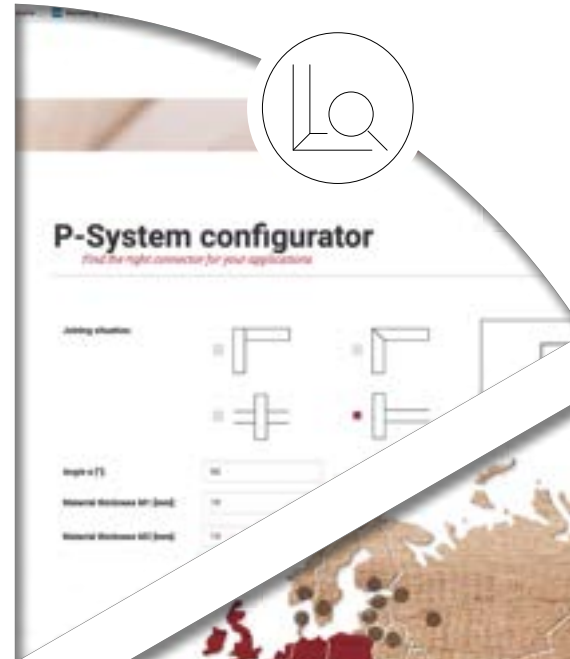
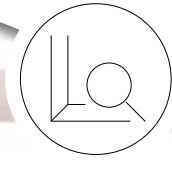

Qualified sales partners

Our professional and committed sales partners provide you with qualified advice, always keeping you informed about new products. This way, you can see the benefits of our products first hand.







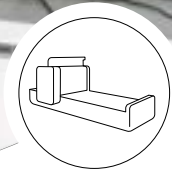





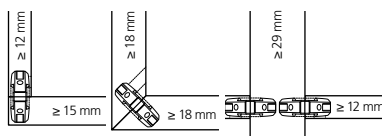

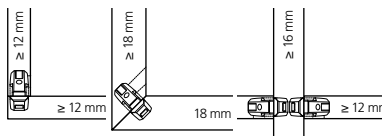

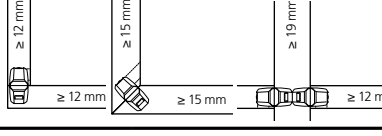
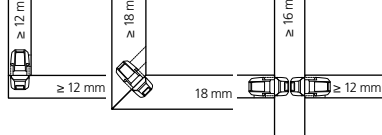
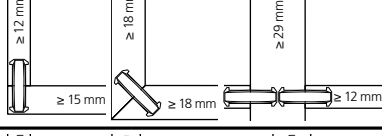
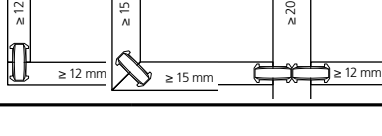

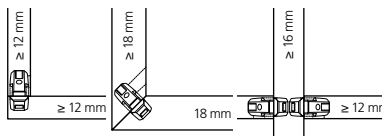

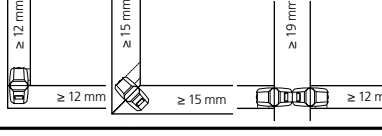
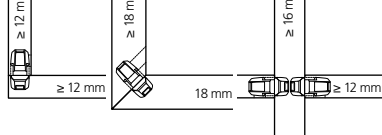
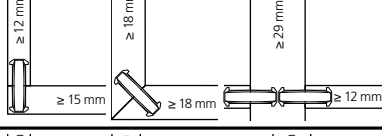
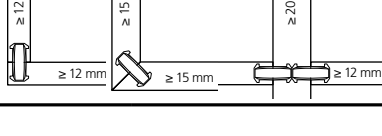
Competent planning and machining partners

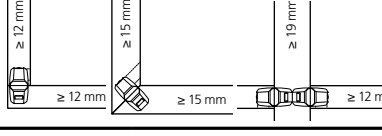

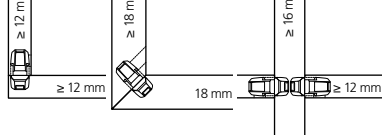
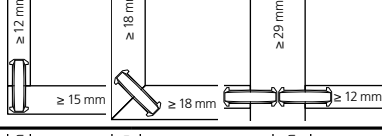
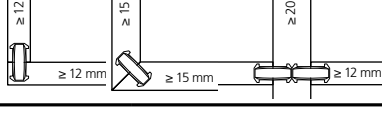

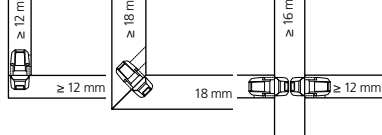

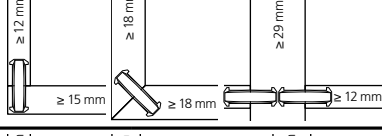
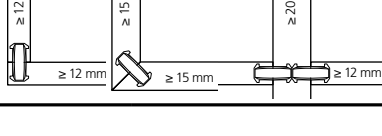
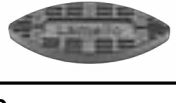
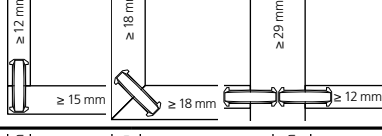

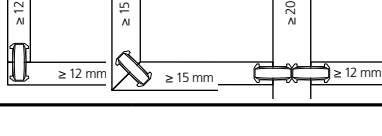
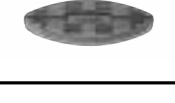
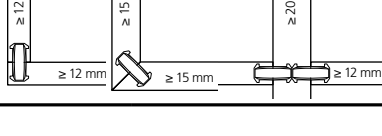
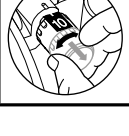

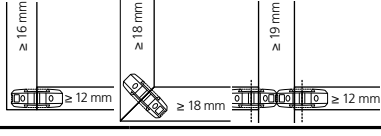
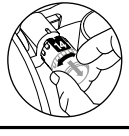
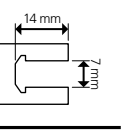
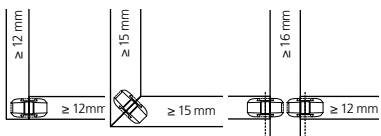
From planning and design to the right tool to machine with the CNC machine: more than 40 industry-leading partner companies support the efficient use and integration of our products into your production.

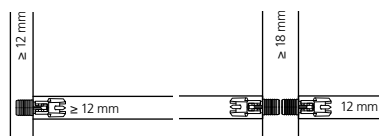

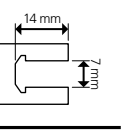
Overview of connectors

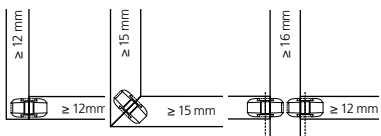
P-System

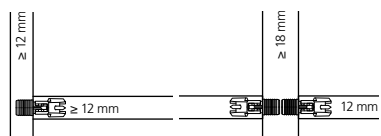
Clamex P Detachable		Clamex P-14	Pairs	Art. No.	Clamex P-14/10 Medius		Clamex P-10	Clamex P-14/10 Flexus	Bisco P-14	Bisco P-10
	80	145334								
	300	145346								
	1000	145356								
	80	145370								
	300	145371								
	1000	145357								
	80	145372								
	300	145373								
	1000	145374								
	80	145315								
	300	145316								
	1000	145317								
	80	145301								
	300	145302								
	1000	145303								
	80	145304								
	300	145305								

Tenso P Glueing		Tenso P-14	Pieces	Art. No.	Tenso P-14 preload clip		Tenso P-10	Divario P Sliding insertion	Divario P-18
	80	145415							
	300	145425							
	1000	145435							
	300	145426							
	1000	145436							
	80	145418							
	80	145418							
	300	145428							
	1000	145438							
	80	145550							
	300	145560							
	1000	145570							

Disclaimer regarding load limits

Wherever we list information on material strength or loads for our products, they are empirical values of load limits, based on specifically defined test conditions similar to DIN 68501:2016-11. Specific characteristics, in particular to the effect that the products will reach the listed loads in the actual used case, are not thereby guaranteed. Rather, it is the responsibility of the respective user to check and ensure the suitability of the products for each specific used case. Since actual load limits substantially depend on circumstances unrelated to the products themselves, e.g. the properties of the carrier materials used, the assembly or the installation environment, any advice provided by us in the form of a product recommendation with regard to a specific suitability is always non-binding and does not release the user from his or her own examination. **To the maximum extent possible under the law, all warranties, express or implied are DISCLAIMED. This includes, but is not limited to, any warranty of fitness for a particular purpose or merchantability. We undertake no responsibility that the goods except as may be included in any contract, and we assume no responsibility that the goods will be fit for any particular purpose, except as may be provided in any contract.**

Subject to modifications and amendments

© Lamello AG. The content of this brochure is protected by copyright and cannot be used for any other purpose without the written consent of Lamello AG.

