

Variable speed pulleys

Type 11.104

Dimensions

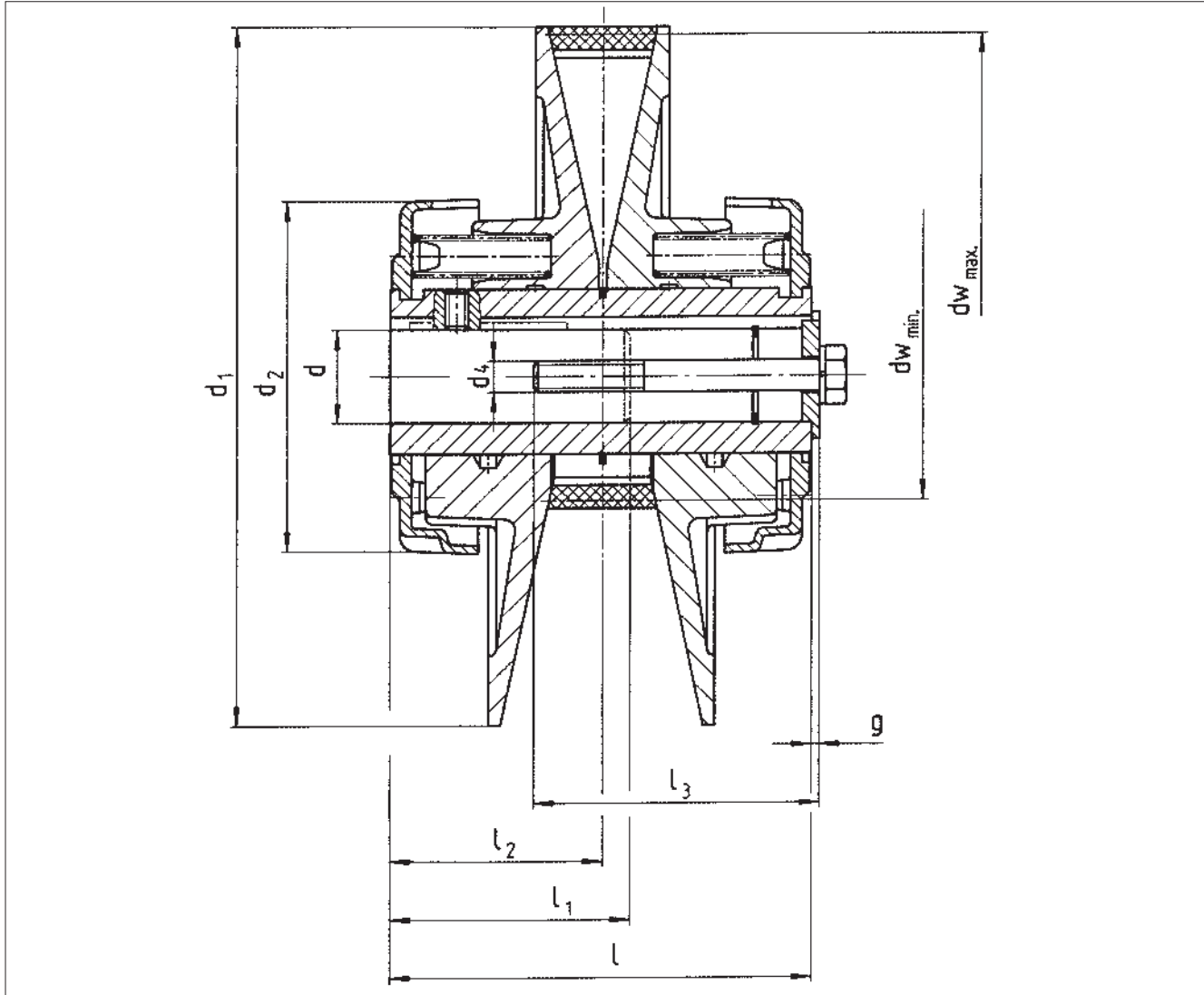

6

Type	Belt size	d ^{H7} 1)		d _w		d ₁	d ₂	Clamping screw ²⁾		g	l	l ₁ min.	l ₂	J [kg m ²]	m [kg]
		min.	Stand	min.	max.			Bore	d ₄ x l ₃						
11.104.05.6.1	22	11	14/19	47	117	120	68	d < 14 d > 14	M 6x 55 M 6x 50	1.5	72	30	36	0.00062	0.77
11.104.10.6.1	28	14	19/24	56	151	155	80	d < 19 d > 19	M 6x 70 M 8x 65	2	94	35	47	0.0022	1.4
11.104.20.6.1	28	19	24/28	64	176	180	90	d < 24 d > 24	M 8x 75 M 10x 70	2	108	40	54	0.0038	2
11.104.30.6.1	37	24	28	72	215	220	104	d < 24 d > 24	M 8x 100 M 10x 95	2	130	50	65	0.0093	3.2

1) Keyway to DIN 6885 part 1

2) Either with clamping screw or threaded pin

Dimensions in [mm]