

POWERNET®

Out Work! Out Play!

VOLLEYBALL TRAINING STATION

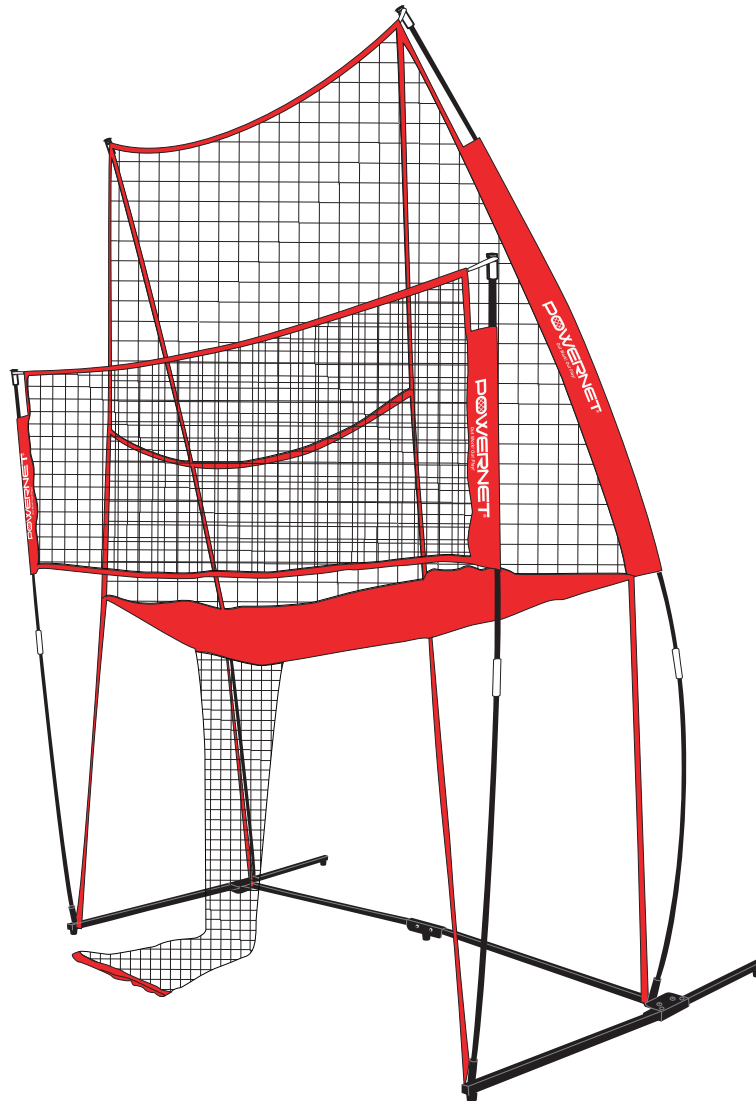

Model V001

WARNING

- Read all instructions before using.
- Use caution during assembly and disassembly. Failure to do so may result in injury.
- Use caution around sliding / moving parts to avoid pinching.
- Store equipment after use. Do not leave outdoors.

FOR VIDEO INSTRUCTIONS VISIT:  **POWERNET**  **TrainingNets.com**

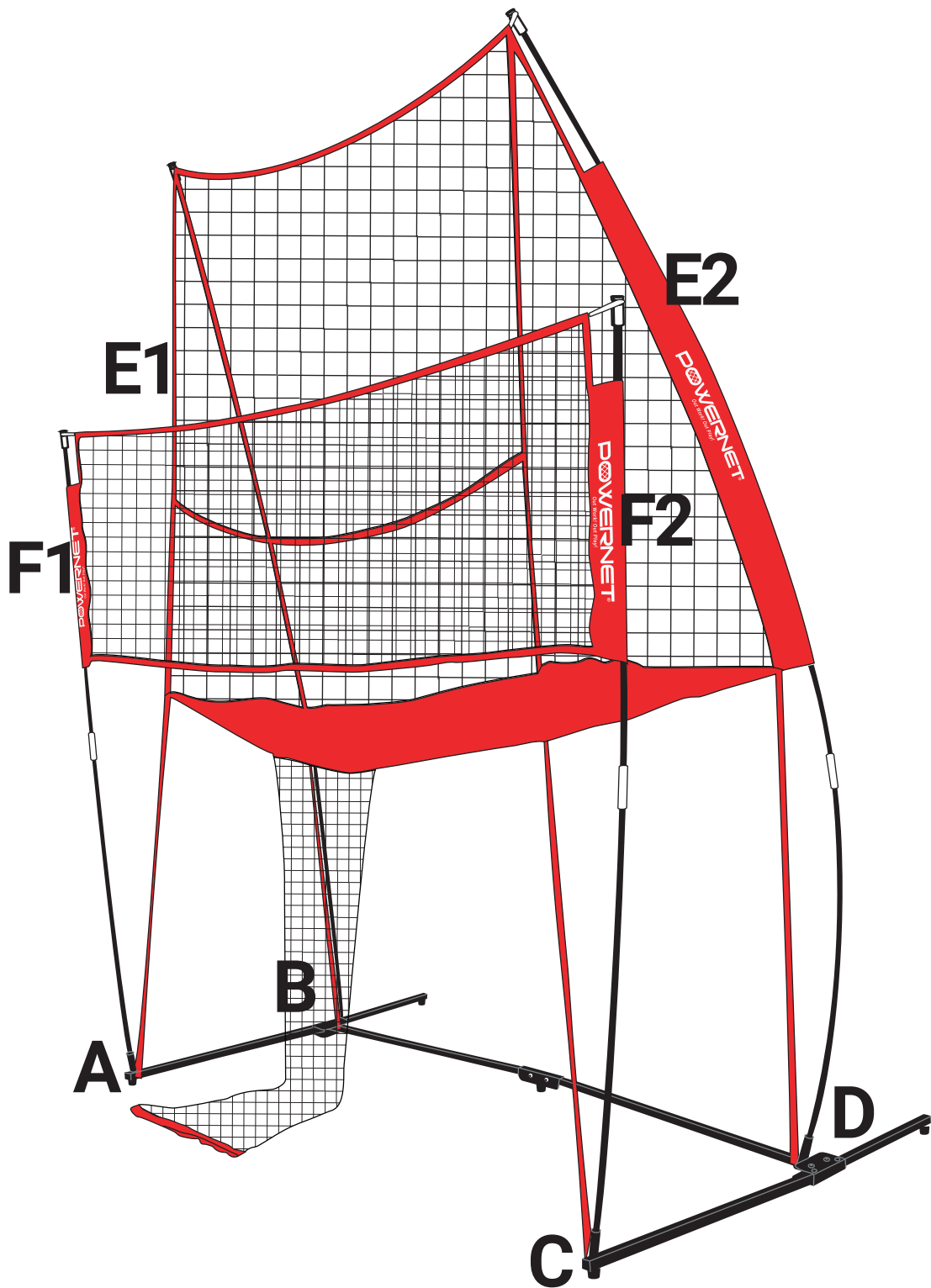

SETUP LOCATIONS

- A. FRONT LEFT SIDE OF FRAME
- B. BACK LEFT SIDE OF FRAME
- C. FRONT RIGHT SIDE OF FRAME
- D. BACK RIGHT SIDE OF FRAME

- E1. LEFT LARGE NET SLEEVE
- E2. RIGHT LARGE NET SLEEVE
- F1. LEFT SMALL NET SLEEVE
- F2. RIGHT SMALL NET SLEEVE

PARTS LIST

(2) UPPER FRONT POLE



(2) UPPER BACK POLE



(6) LOWER POLE

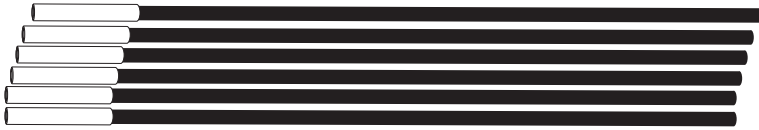

(1) BASE FRAME

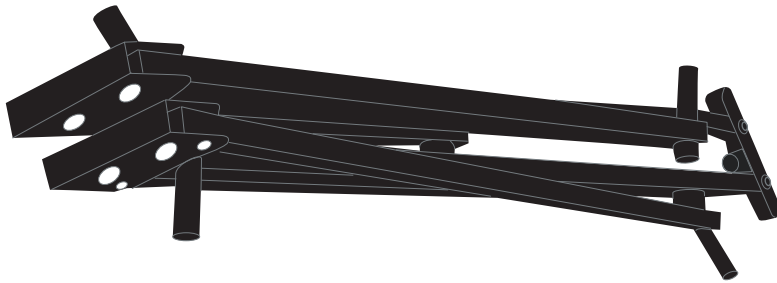

(1) LARGE NET

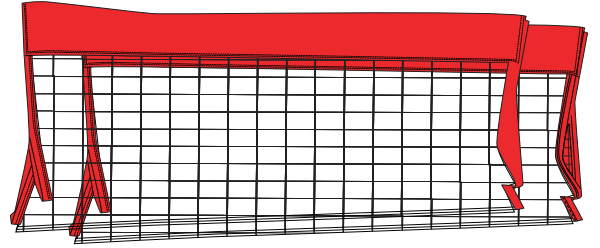

(1) SMALL NET

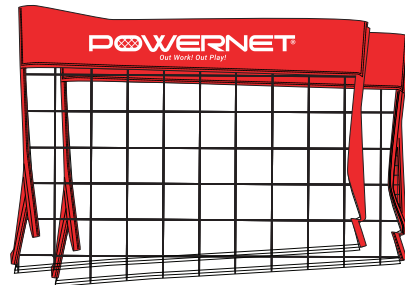

1 Unfold the **Base Frame** to flatten out on the ground.

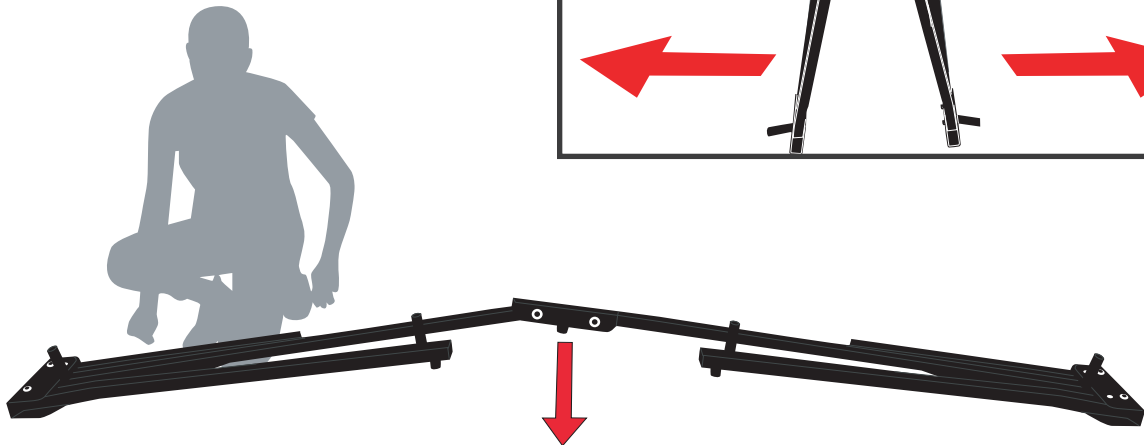
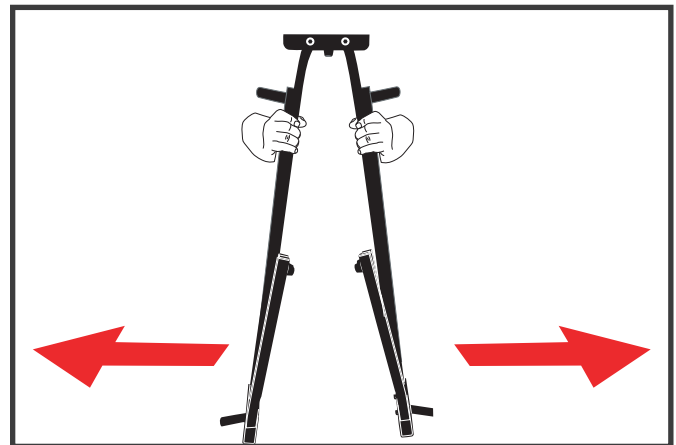

2 Open **Base Frame** legs until the buttons snap into place. Repeat on opposite side.

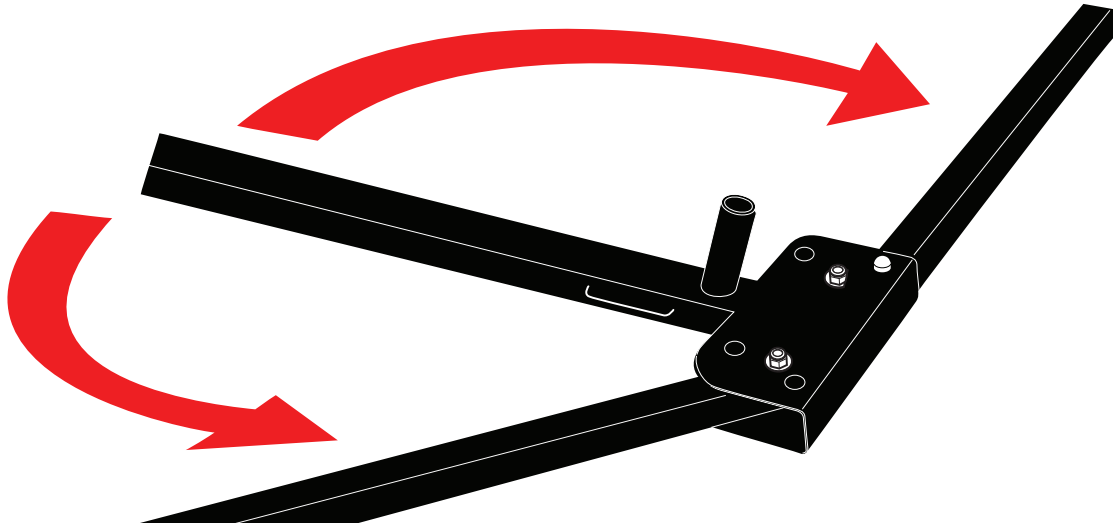

3 Insert a **Lower Pole** into pole holder on the **Base Frame**. Repeat on opposite side. (Locations B and D)

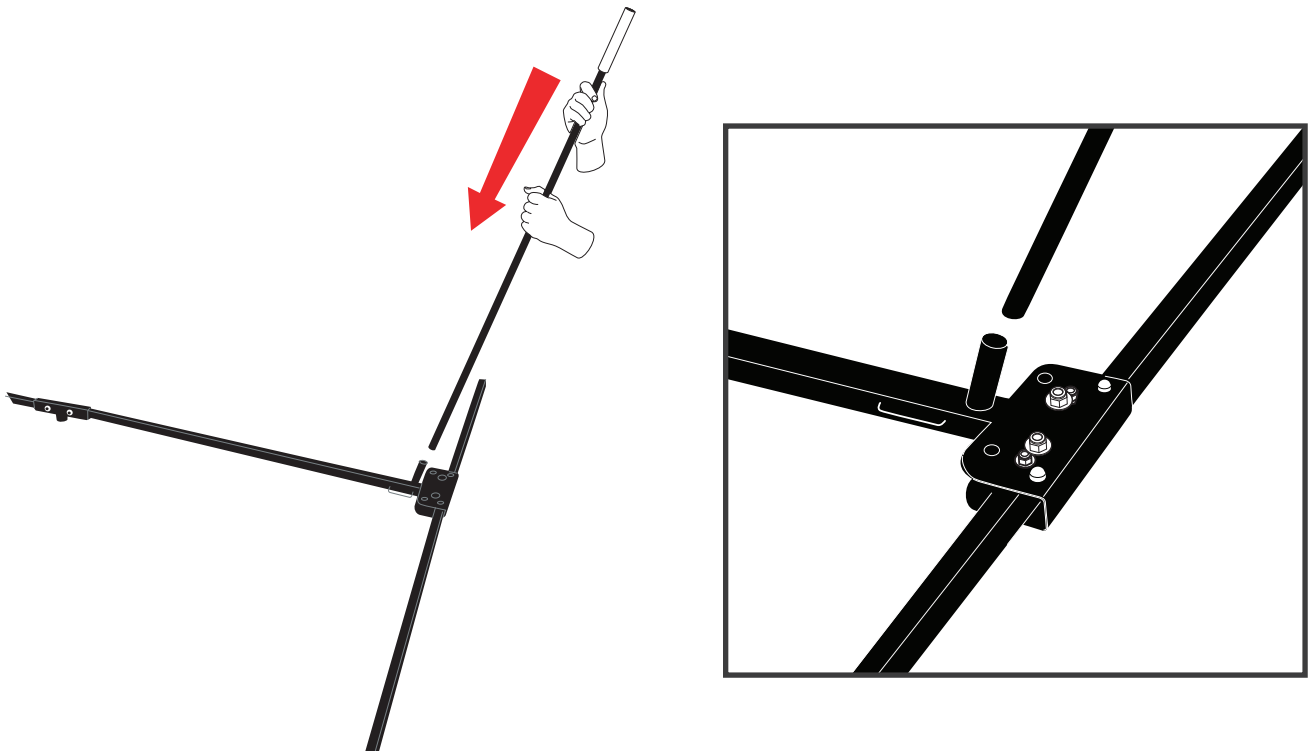

4a

Slide an **Upper Back Pole** through **Large Net** sleeve. (Either **E1** or **E2**)

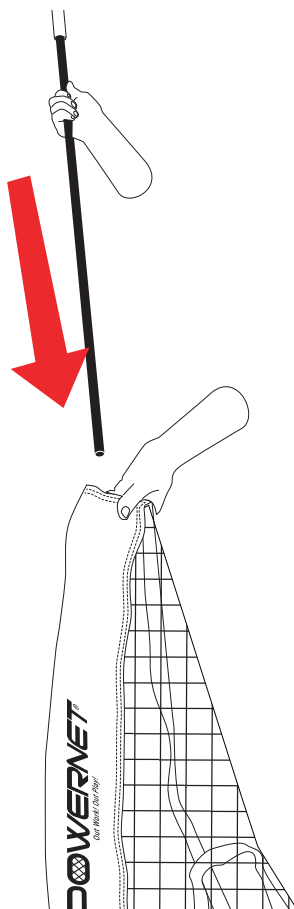

4b

Wrap the white loop located on **Large Net** around the silver notch located at the top of **Upper Back Pole**.

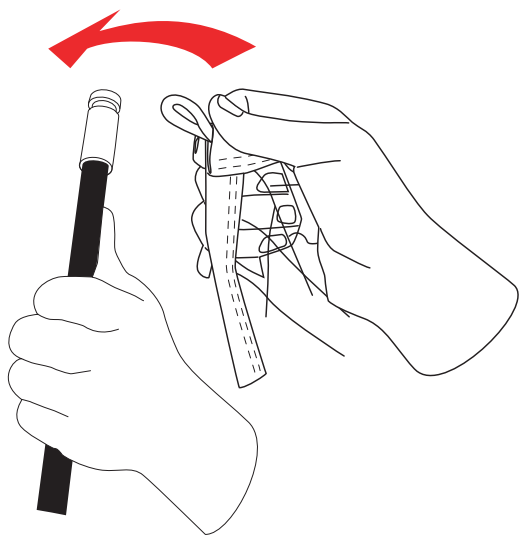

4c

Now, insert the **Upper Back Pole** (with the **Large Net** still attached) into a **Lower Pole**. Then, insert the two connected poles into the **Lower Pole** already located in the **Base Frame** pole holder. Repeat steps 4a-4c on opposite side.

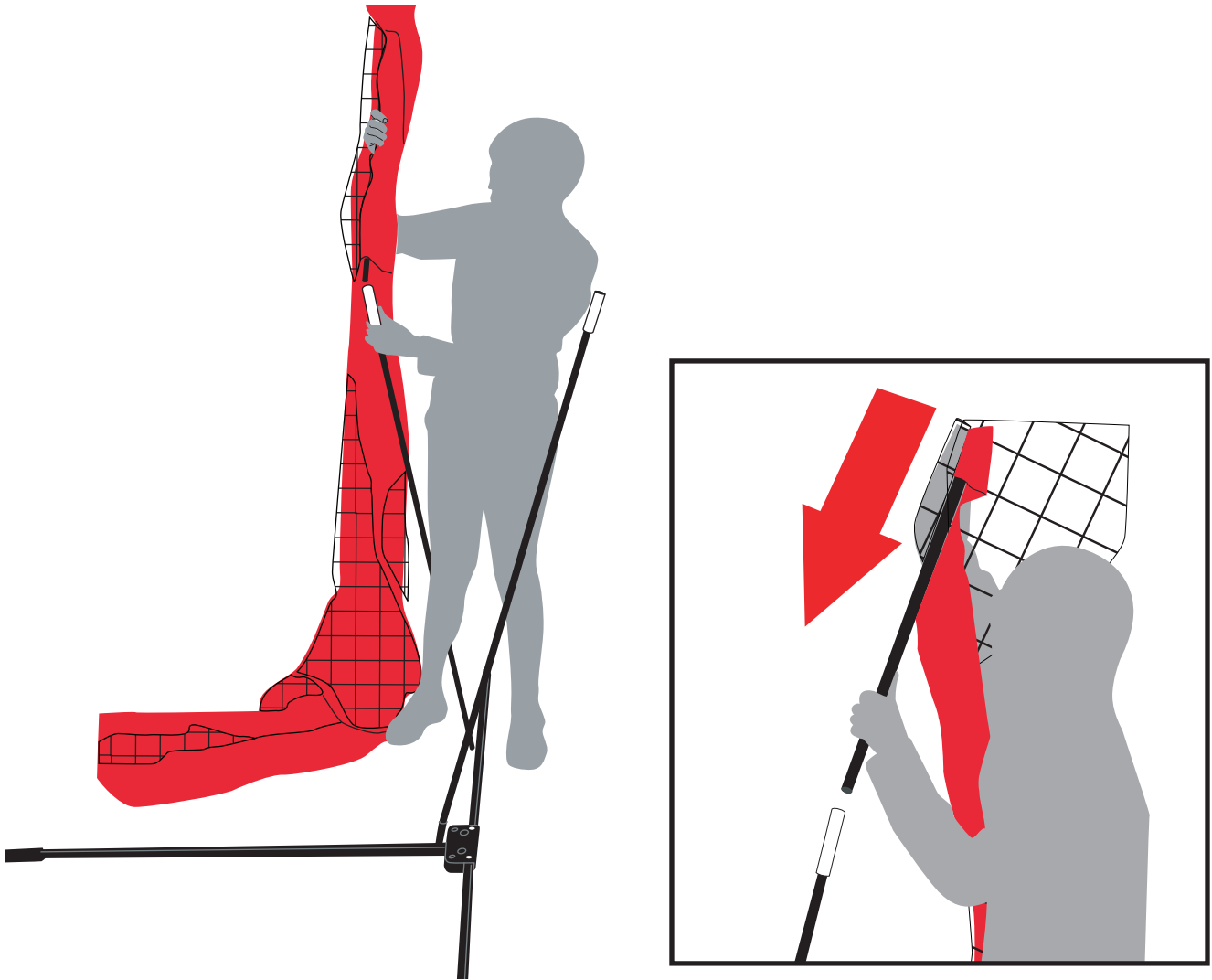

NOTE: After completing step 4, your net should look like this:

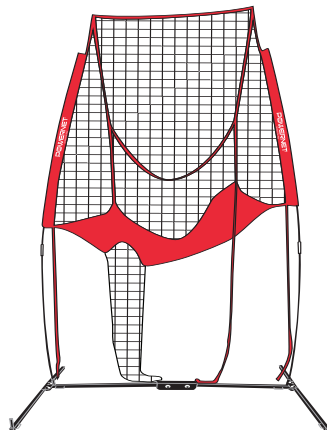

5

Fasten the four red securing straps on the **Net** to **A, B, C,** and **D** on the **Base Frame**.

Base Side Leg

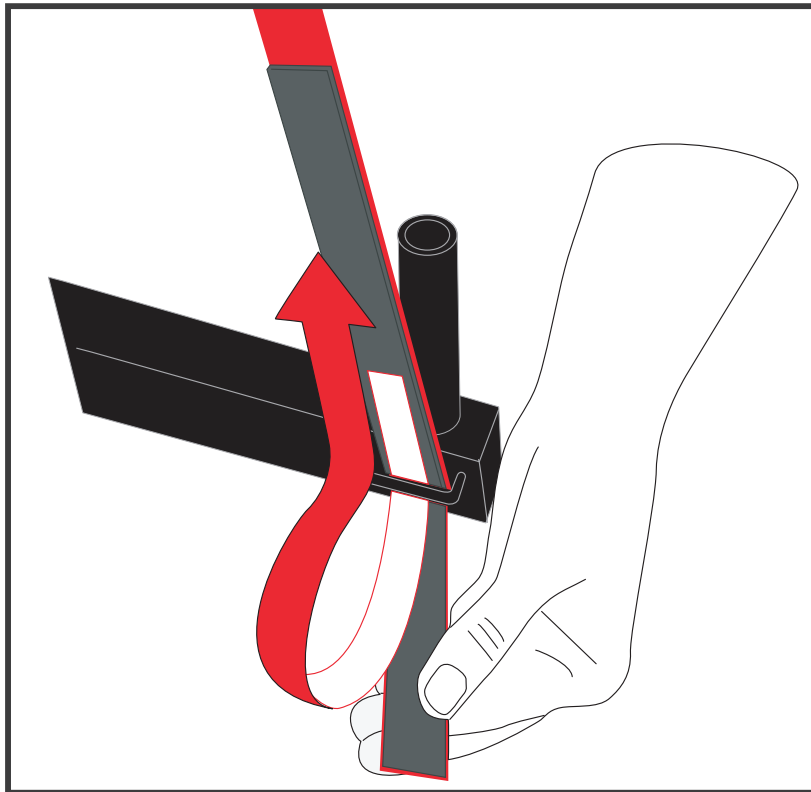

Base Middle Bar

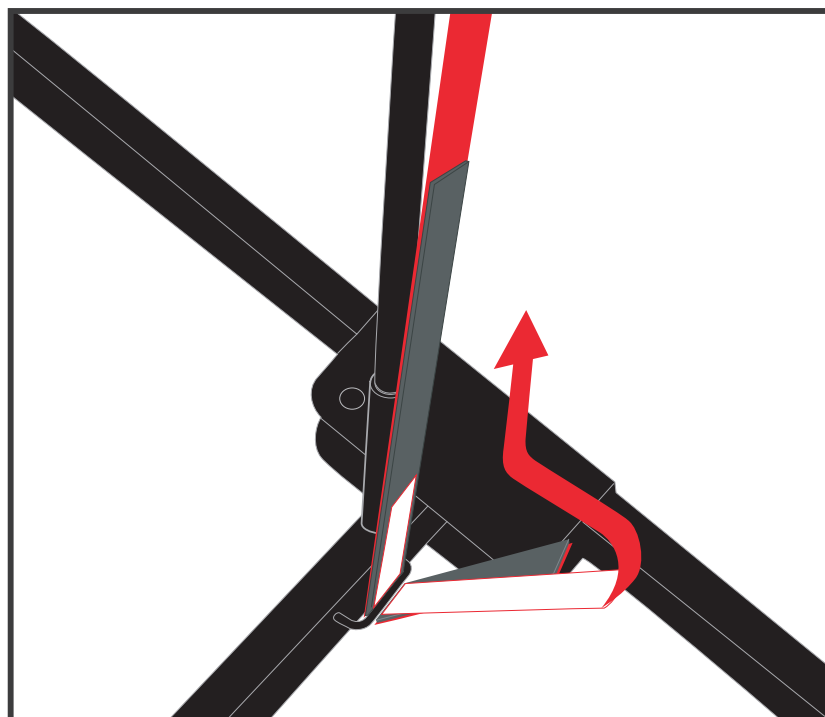

6

Insert a **Lower Pole** into each pole holder located at **A** and **C**.

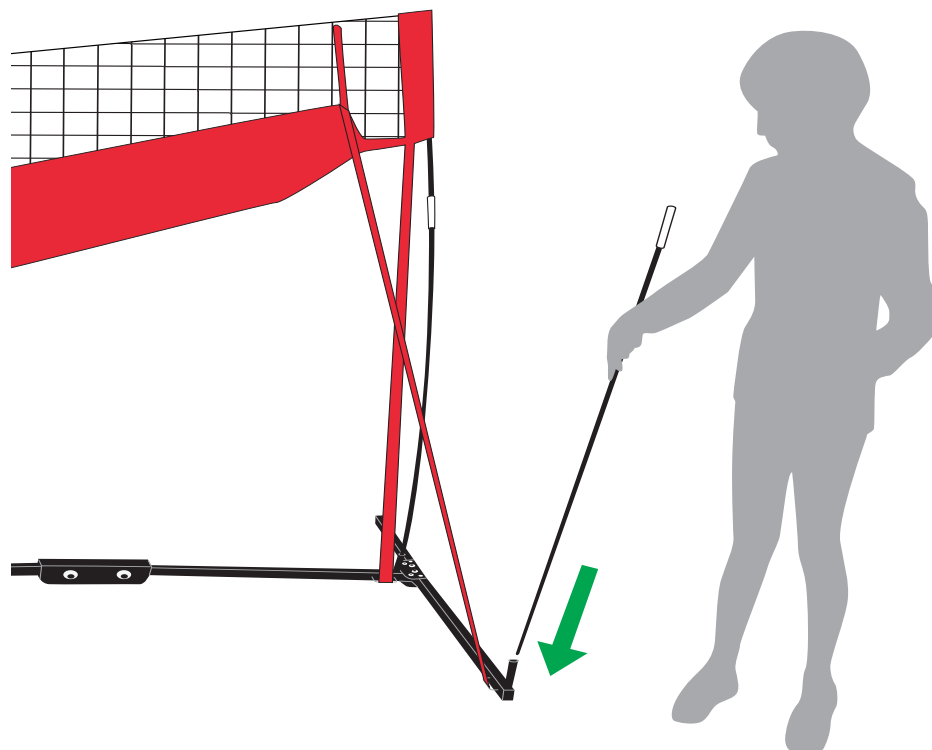

7a

Slide **Front Upper Pole** through sleeve **F1** or **F2** on the **Small Net**.

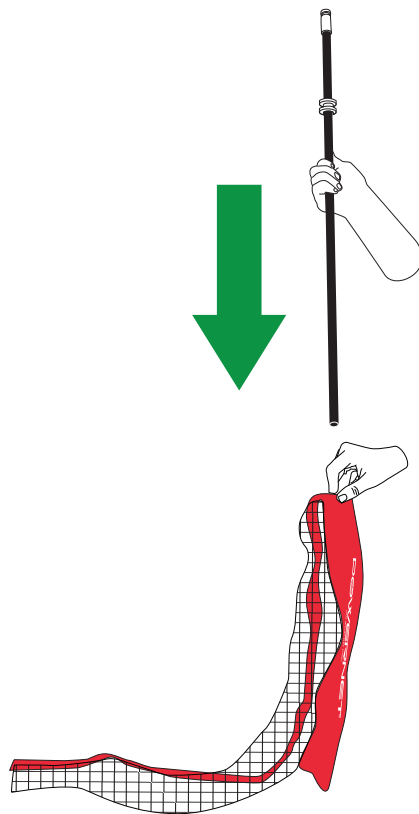

7b

Wrap the white loop located on **Small Net** around either silver notch (depending on desired height) located on **Front Upper Pole**:

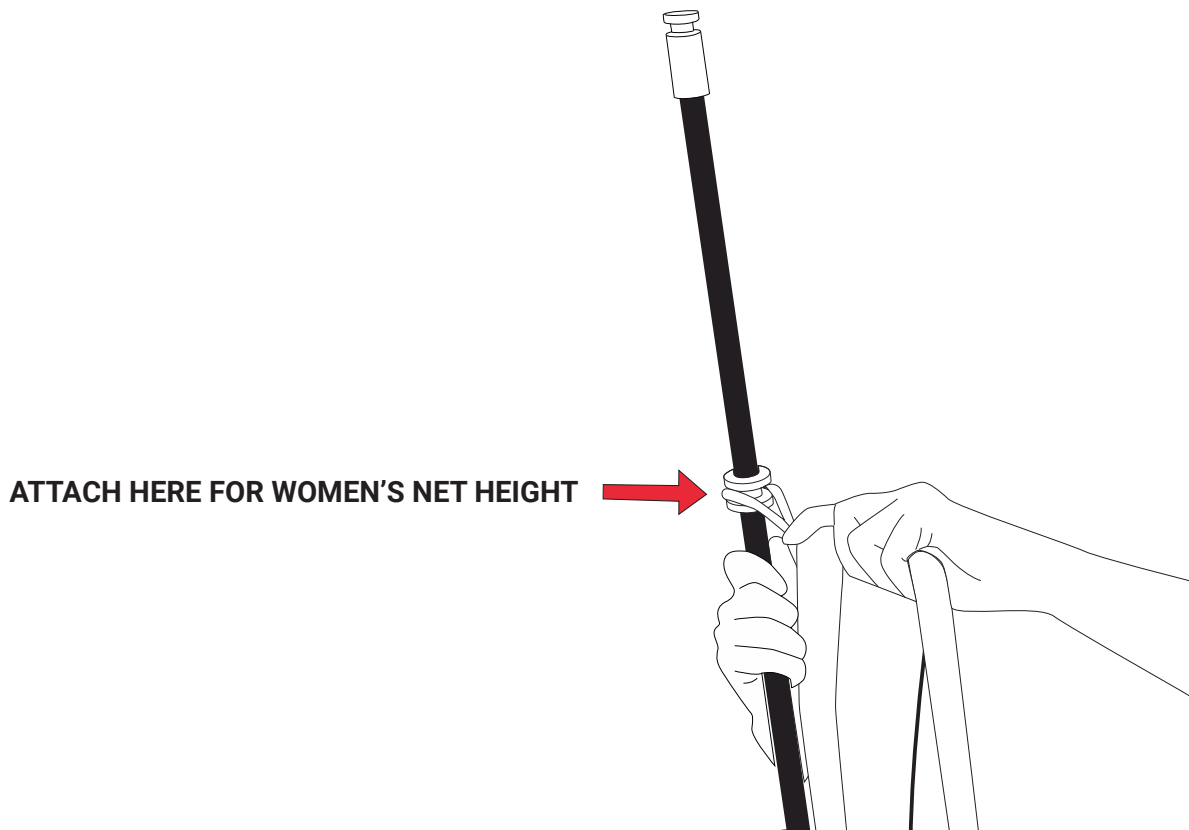
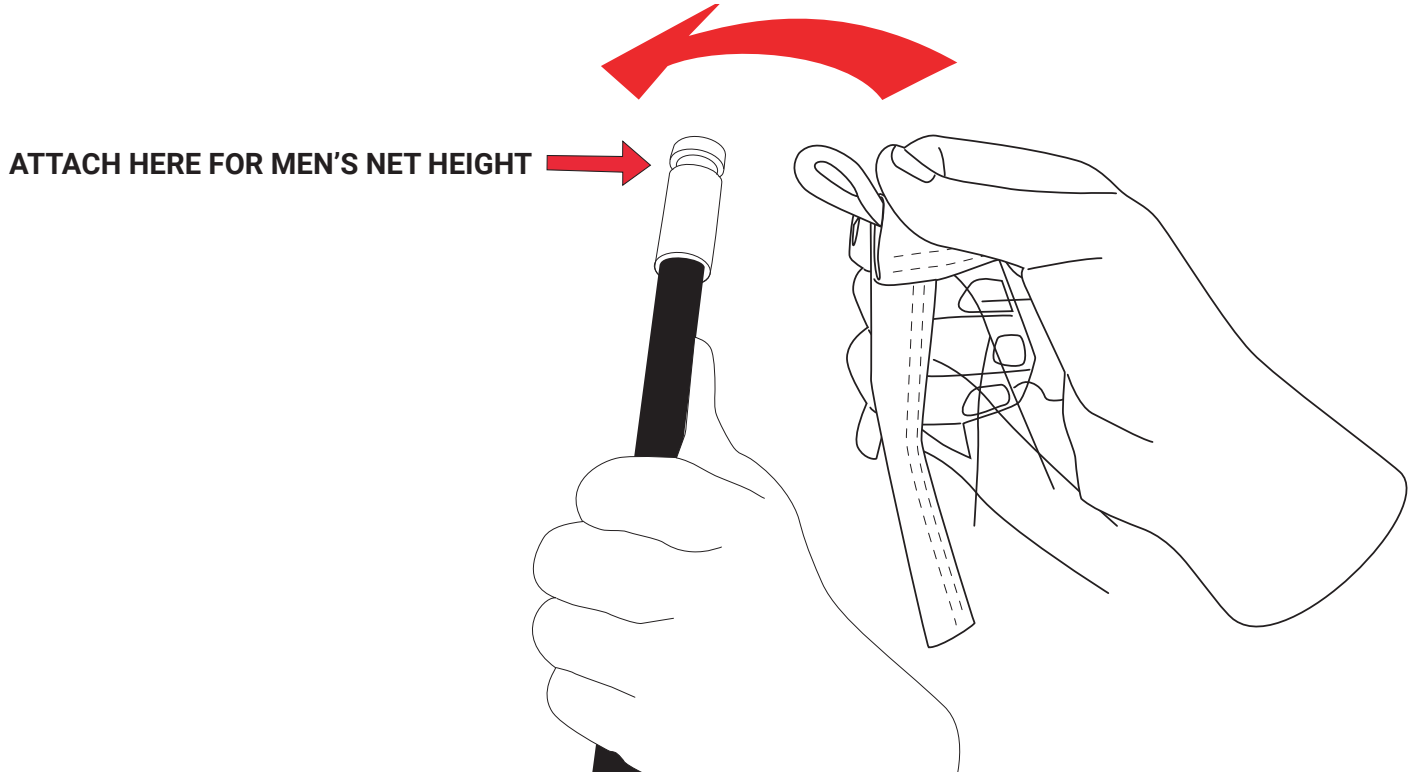

7c

Lift and insert the **Upper Front Pole** (with the **Small Net** still attached) into the **Lower Pole**. Repeat steps 7a-7c on the opposite side.

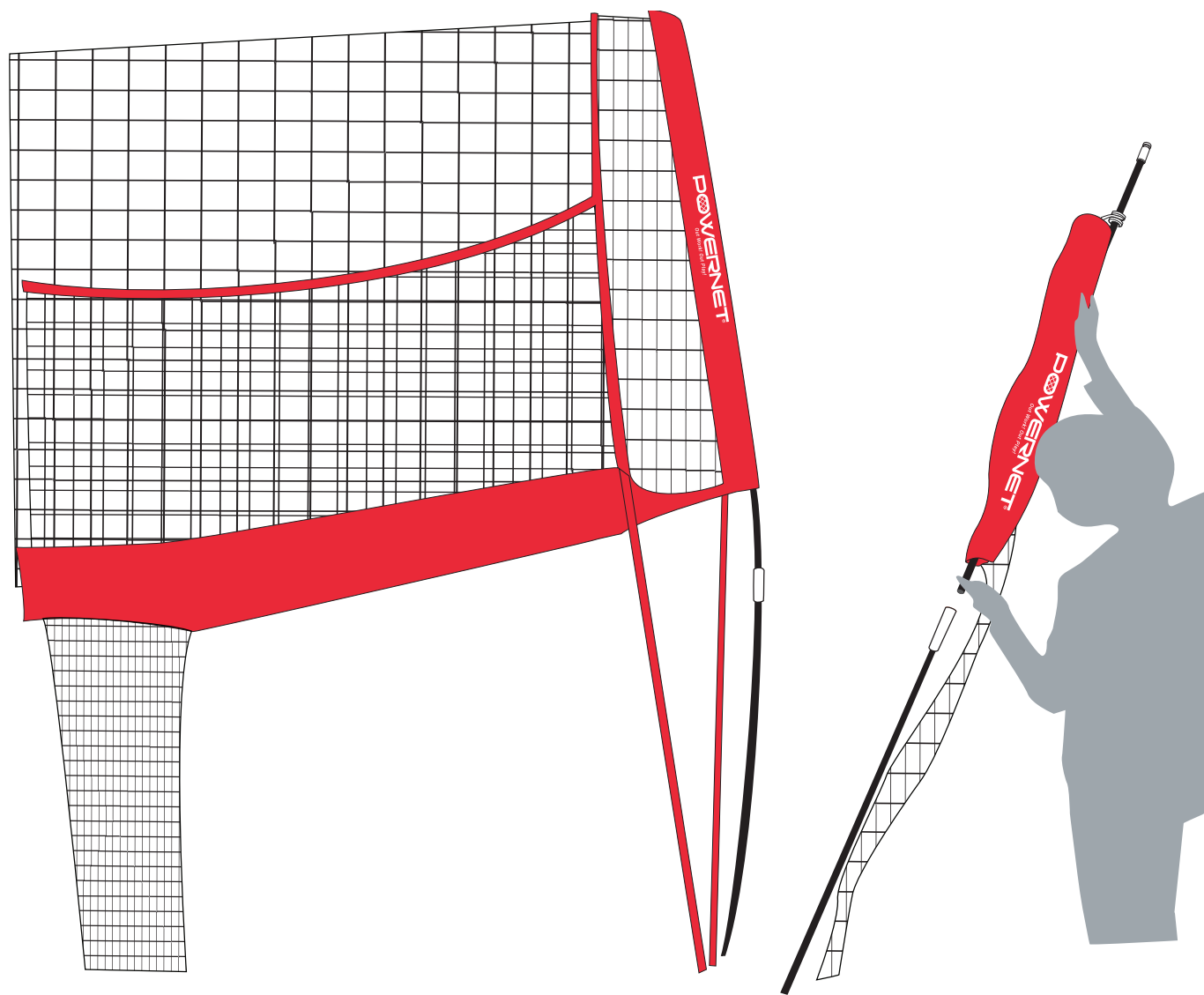

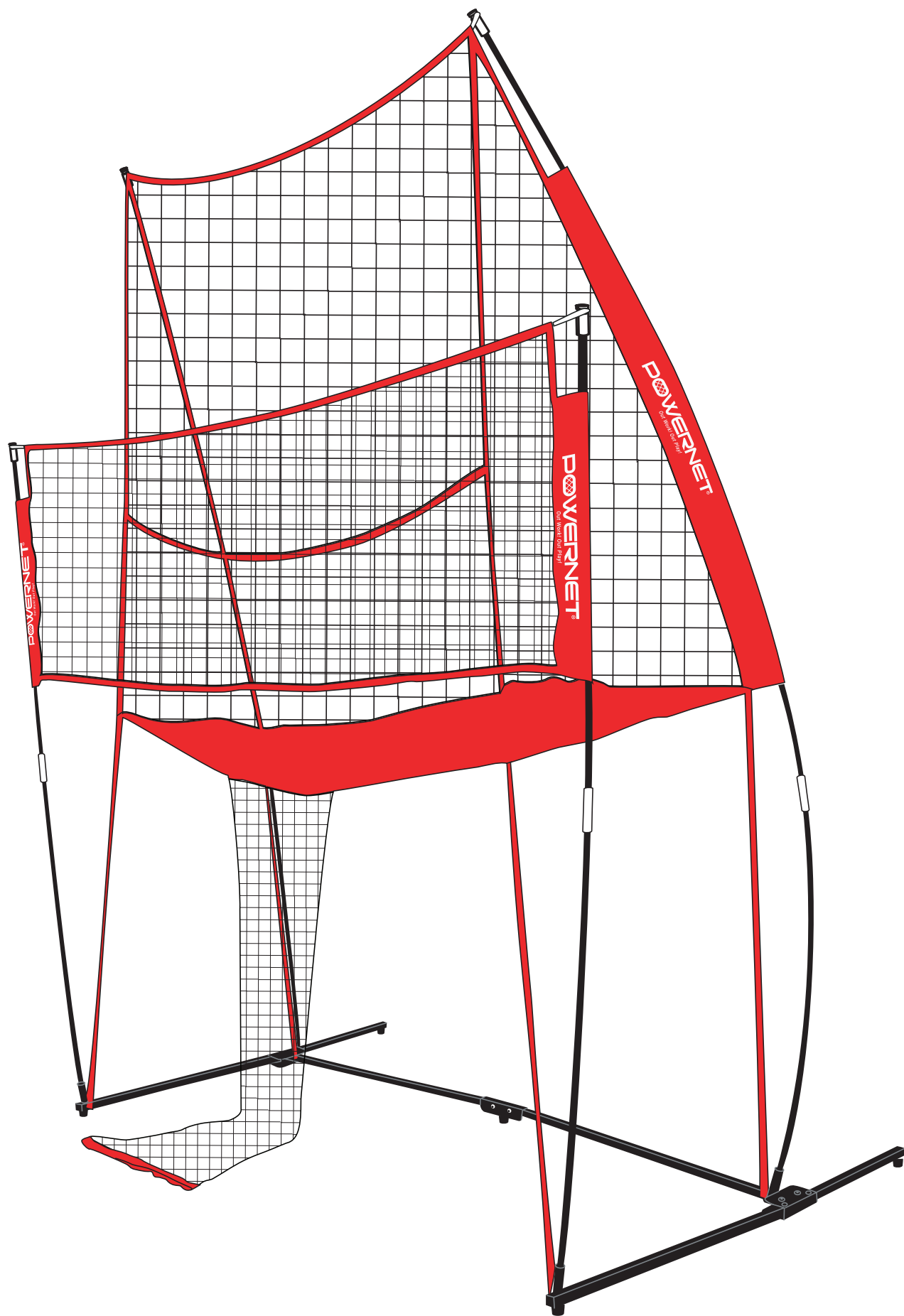

POWERNET®

Out Work! Out Play!

OUR VISION

Building confidence through sports is a far-reaching achievement that takes time and repetition.

Winners aren't built overnight. Individuals who challenge themselves to excel in sports walk away with something even greater than the game; pride, confidence and self-respect. This places them in a position to experience sustained success in all areas. Our driving force is to get PowerNet gear in the hands of the player. We trust in the process of training and hard work as we know it leads to success on and off the field. Our hope is to play a role in building winners in sports and in life.

**PLAY LIKE
THE PROS.**

**GERMAN
MARQUEZ**

**CARLI
LLOYD**

**JARED
WALSH**

**CHECK OUT MORE
POWERNET GEAR**
TrainingNets.com



VOLLEYBALL
SETTER

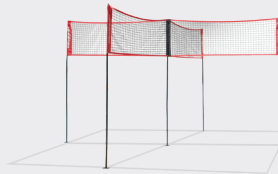

4-WAY VOLLEYBALL
NET



VOLLEYBALL
WARM-UP NET

FOR VIDEO INSTRUCTIONS VISIT:



POWERNET

www.PowerNetInc.net | 909.203.5495