

# POWERNET®

*Out Work! Out Play!*

## 7X7 FT TRIPLE THREAT NET

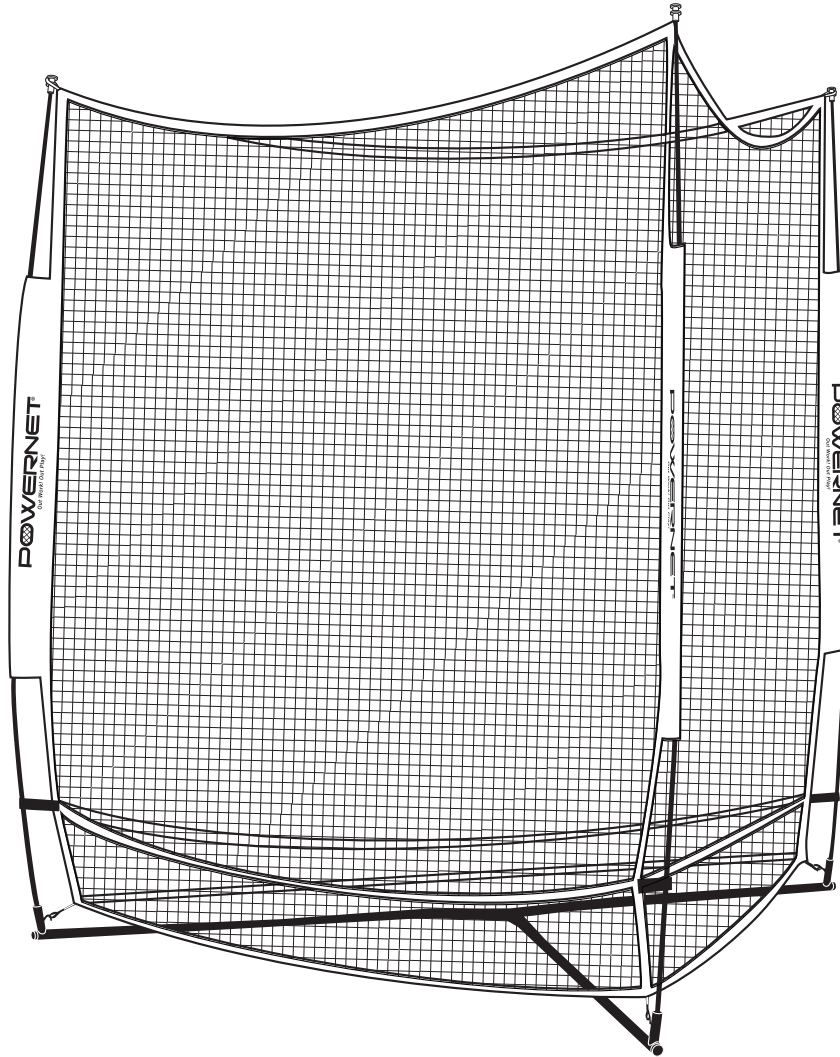

**Model 1124**

### **⚠ WARNING**

- Read all instructions before using.
- Poles are under tension. Use caution during assembly and disassembly. Failure to do so may result in injury.
- Use caution around sliding / moving parts to avoid pinching.
- Store equipment after use. Do not leave outdoors.

FOR VIDEO INSTRUCTIONS VISIT:  **POWERNET**  **TrainingNets.com**

## PARTS LIST

NET

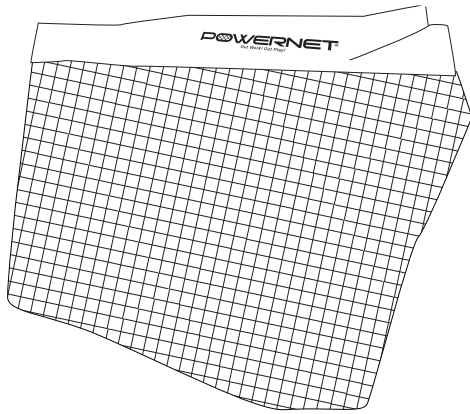

MIDDLE CONNECTOR

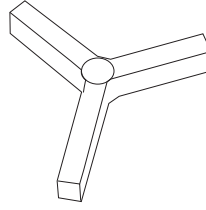

CARRY BAG



LEG (x3)

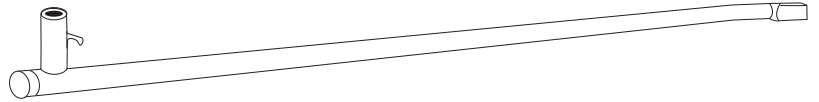

UPPER POLE (x3)



SCREW TOP (x3)  
(on upper pole)

SANDBAGS (x3)

LOWER POLE (x3)



**1**

Place **Middle Connector** (with the buttons facing **DOWN**) where you want the center of the **Net**.

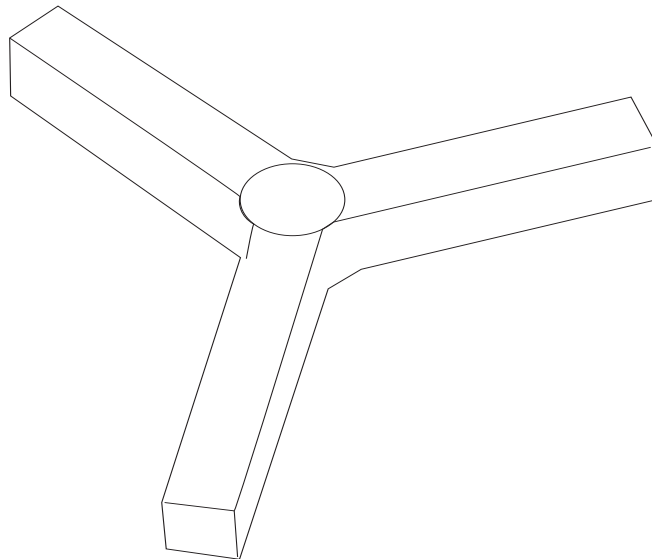

**2**

Connect a **Leg** to a **Middle Connector** side. Repeat on each remaining side.

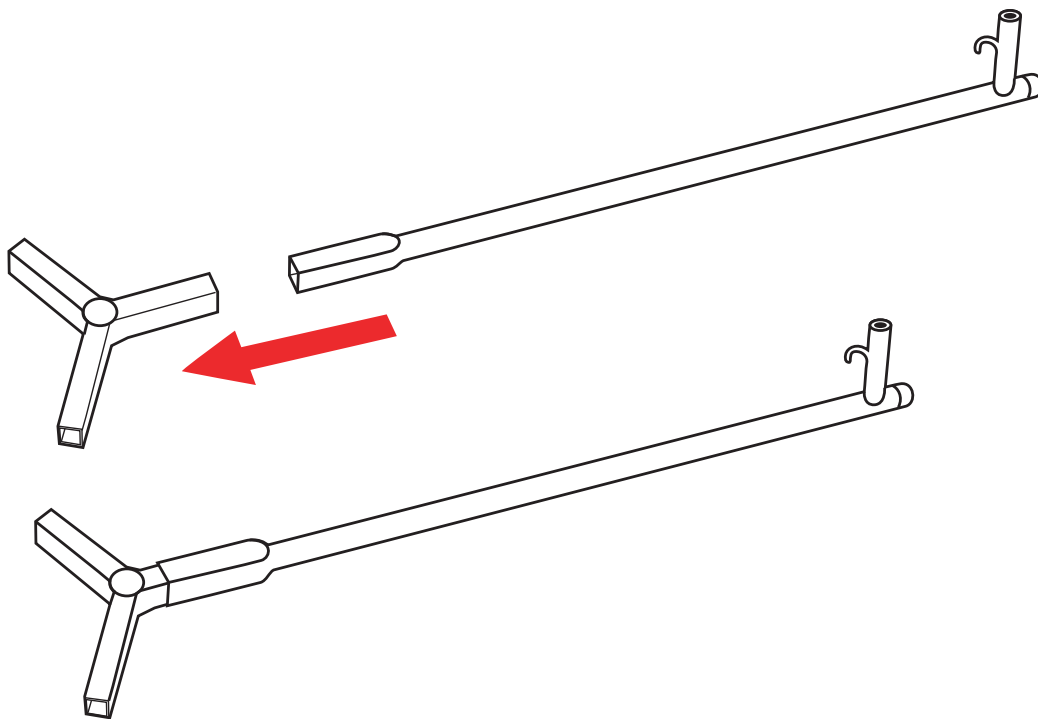

**Note:** Once each **Leg** is connected, frame should appear as shown here:

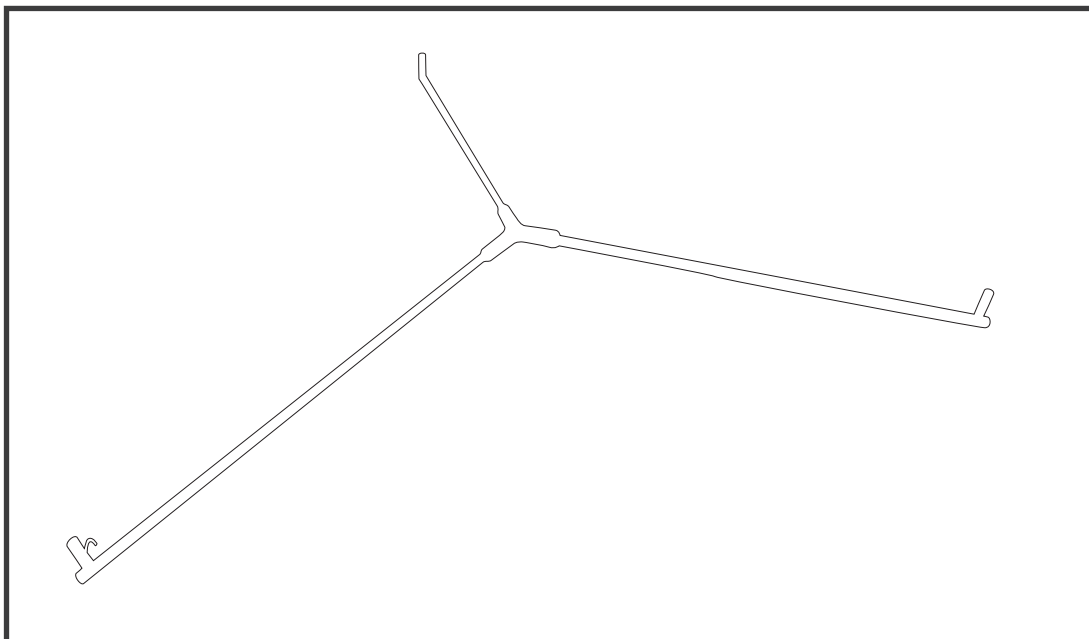

**3a** Remove the screw top from the **Upper Pole**.  
Then, insert an **Upper Pole** into a **Lower Pole**.

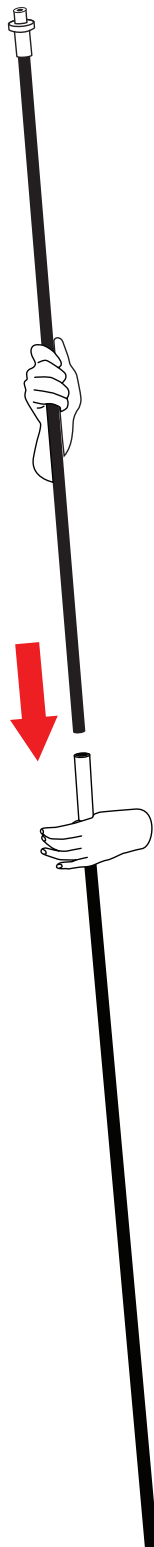
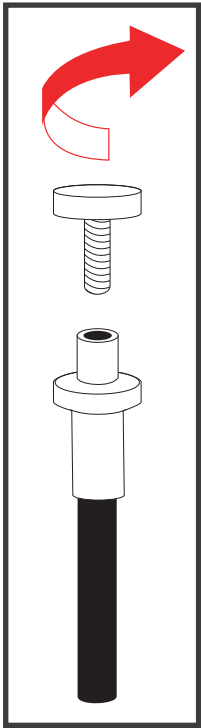

**3b** Slide connected **Upper and Lower Poles**

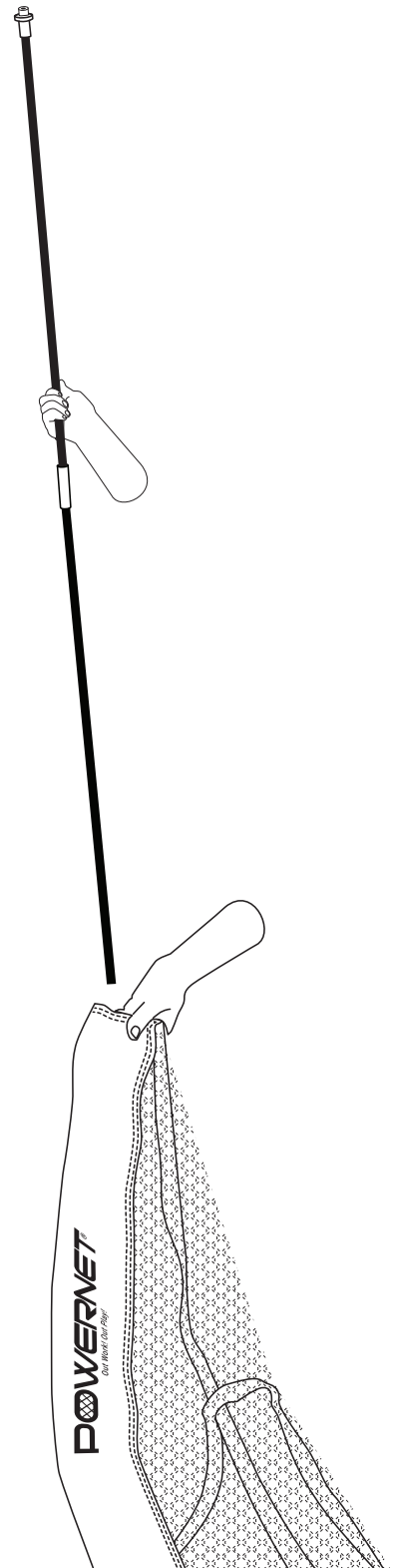

**3c** Slide the connected **Upper** and **Lower Poles** through the black loop at the bottom of the **Net** and into the pole holder located on the **Leg**.

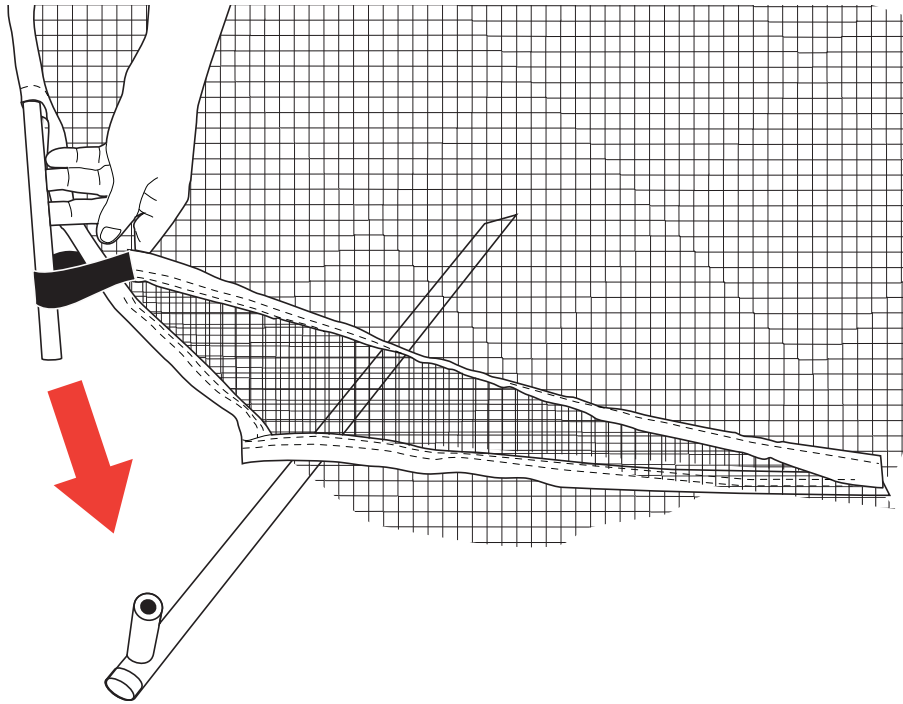

**3d** Pull **Upper Pole** inward and hook white loop on the **Net** around the silver notch.

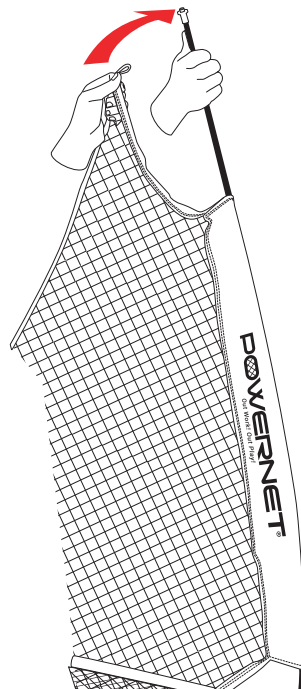

**3e**

Secure a **Screw Top** to an **Upper Pole** by screwing in tightly. Repeat steps 3a-3e on remaining two sides.

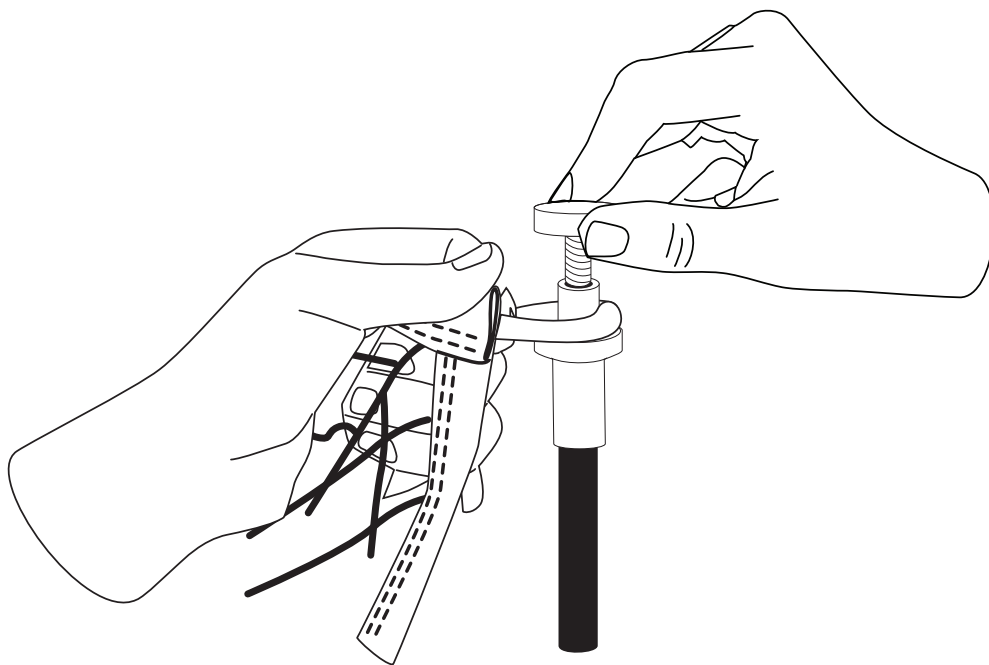

**4**

Locate lower black bungee on bottom corner of **Net** and loop onto small hook on base **Leg**. Repeat on remaining 2 sides.

You may fill and attach the included sandbags here if additional weight is desired.

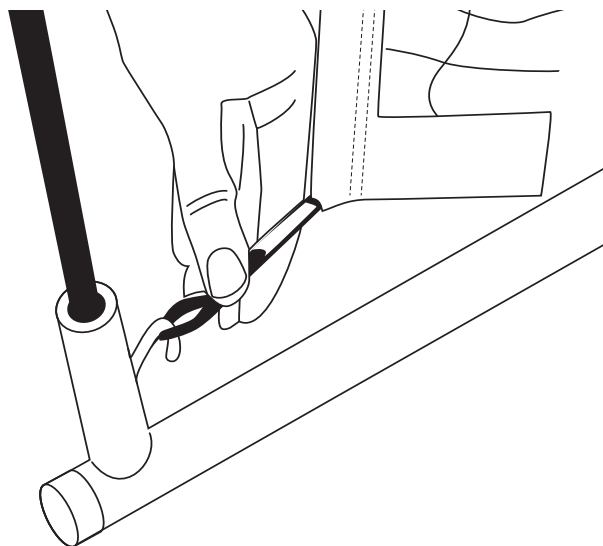

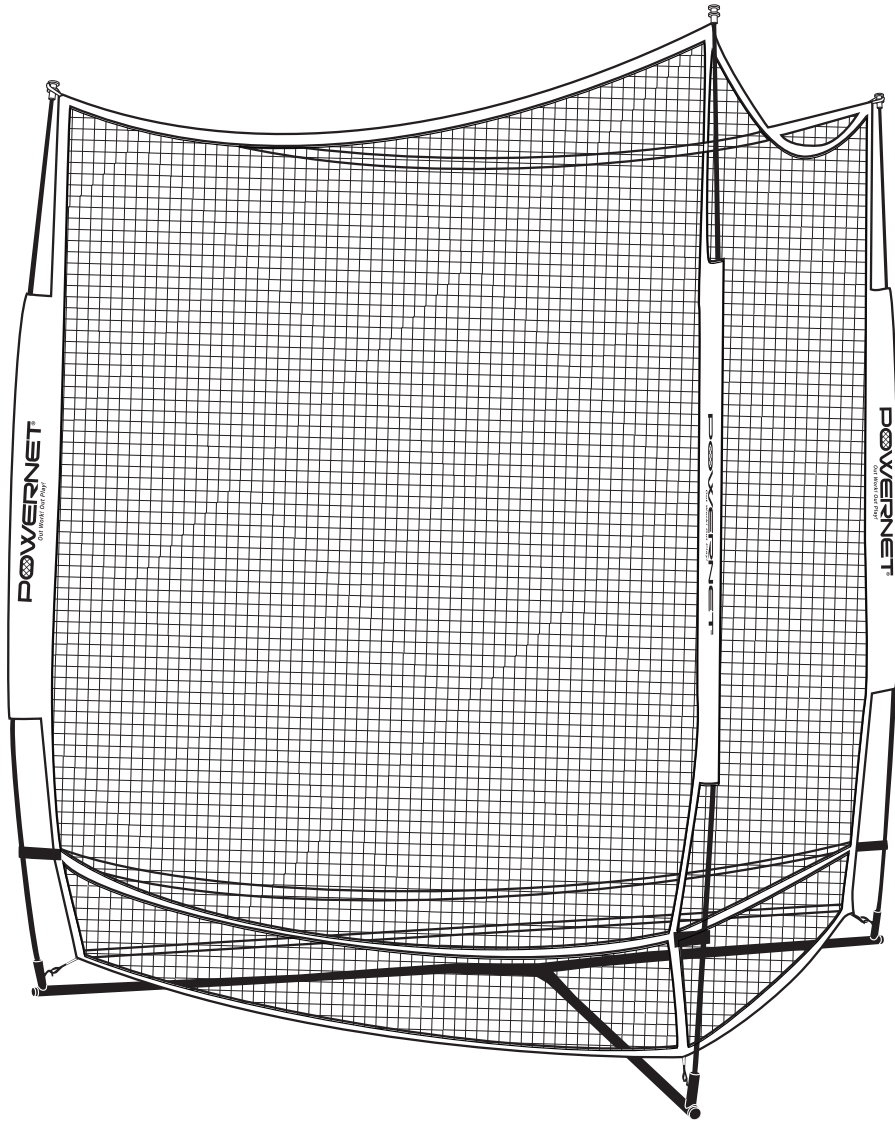

# POWERNET®

*Out Work! Out Play!*

## OUR VISION

Building confidence through sports is a far-reaching achievement that takes time and repetition.

Winners aren't built overnight. Individuals who challenge themselves to excel in sports walk away with something even greater than the game; pride, confidence and self-respect. This places them in a position to experience sustained success in all areas. Our driving force is to get PowerNet gear in the hands of the player. We trust in the process of training and hard work as we know it leads to success on and off the field. Our hope is to play a role in building winners in sports and in life.

**CHECK OUT MORE  
POWERNET GEAR**  
*[TrainingNets.com](http://TrainingNets.com)*



7x7 Ft PRACTICE NET

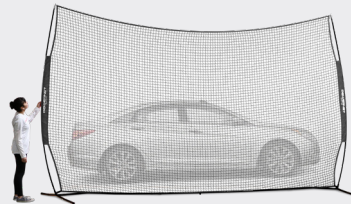

16x10 Ft BARRIER



BATTING TEE

FOR VIDEO INSTRUCTIONS VISIT:



**POWERNET**

[www.PowerNetInc.net](http://www.PowerNetInc.net) | 909.203.5495