

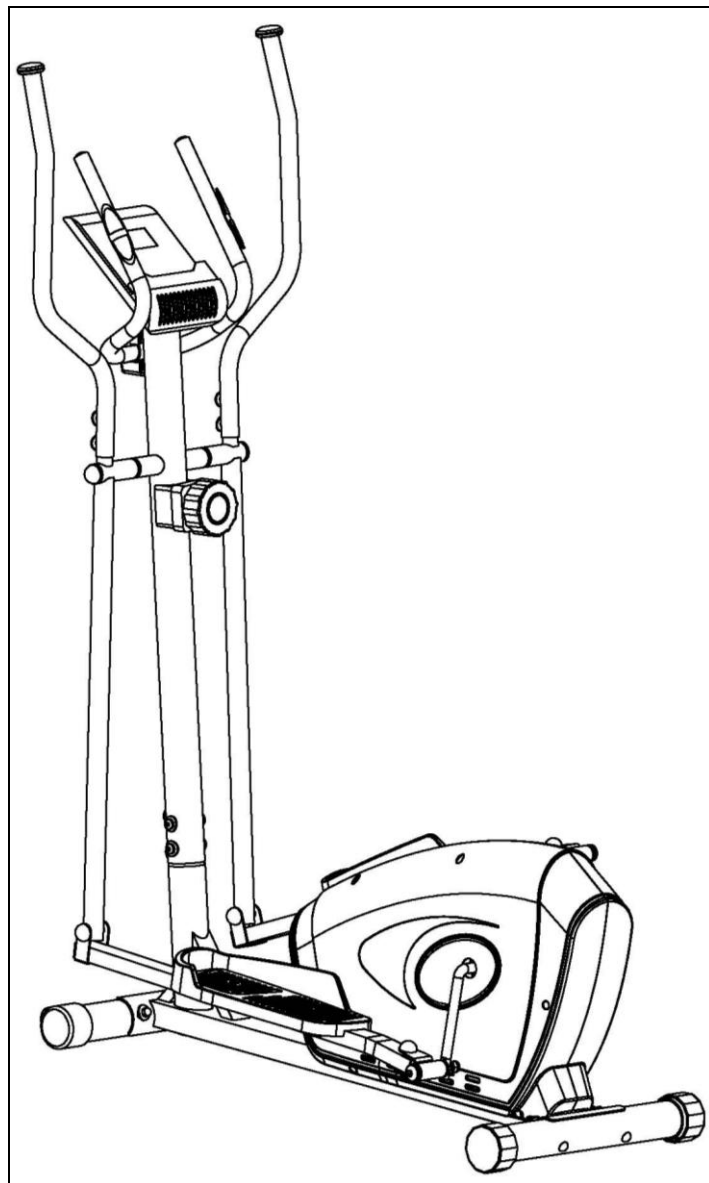

MAGNETIC ELLIPTICAL TRAINER

SF-E3607

USER MANUAL



IMPORTANT! Please retain owner's manual for maintenance and adjustment instructions. Your satisfaction is very important to us, **PLEASE DO NOT RETURN UNTIL YOU HAVE CONTACTED US:** support@sunnyhealthfitness.com or 1- 877 - 90SUNNY (877-907-8669).



WWW.SUNNYHEALTHFITNESS.COM

IMPORTANT SAFETY INFORMATION

We thank you for choosing our product. To ensure your safety and health, please use this equipment correctly. It is important to read this entire manual before assembling and using the equipment. Safe and effective use can only be achieved if the equipment is assembled, maintained and used properly. It is your responsibility to ensure that all users of the equipment are informed of all warnings and precautions.

1. Before starting any exercise program, you should consult your physician to determine if you have any medical or physical conditions that could put your health and safety at risk, or prevent you from using the equipment properly. Your physician's advice is essential if you are taking medication that affects your heart rate, blood pressure or cholesterol level.
2. Be aware of your body's signals. Incorrect or excessive exercise can damage your health. Stop exercising if you experience any of the following symptoms: pain, tightness in your chest, irregular heartbeat, shortness of breath, lightheadedness, dizziness or feelings of nausea. If you do experience any of these conditions, you should consult your physician before continuing with your exercise program.
3. Keep children and pets away from the equipment. The equipment is designed for adult use only.
4. Use the equipment on a solid, flat level surface with a protective cover for your floor or carpet. To ensure safety, the equipment should have at least 2 feet (60 CM) of free space all around it.
5. Ensure that all nuts and bolts are securely tightened before using the equipment. The safety of the equipment can only be maintained if it is regularly examined for damage and/or wear and tear.
6. Always use the equipment as indicated. If you find any defective components while assembling or checking the equipment, or if you hear any unusual noises coming from the equipment during exercise, discontinue use of the equipment immediately and do not use until the problem has been rectified.
7. Wear suitable clothing while using the equipment. Avoid wearing loose clothing that may become entangled in the equipment.
8. Do not place fingers or objects into the moving parts of the equipment.
9. The maximum weight capacity of this unit is 220 pounds (100 KG).
10. The equipment is not suitable for therapeutic use.
11. To avoid bodily injury and/or damage to the product or property, proper lifting and moving is required.
12. Your product is intended for use in cool, dry conditions. You should avoid storage in extreme cold, hot or damp areas as this may lead to corrosion and other related problems.
13. This equipment is designed for indoor and home use only, it is not intended for commercial use!

EXPLODED DIAGRAM

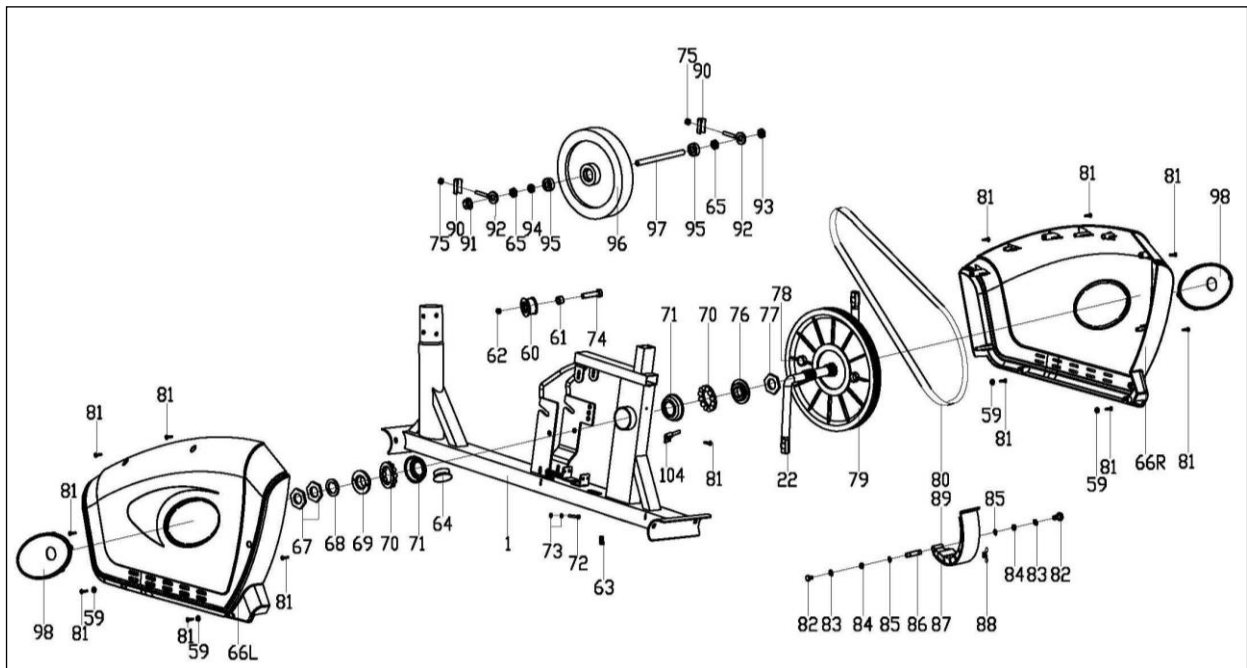
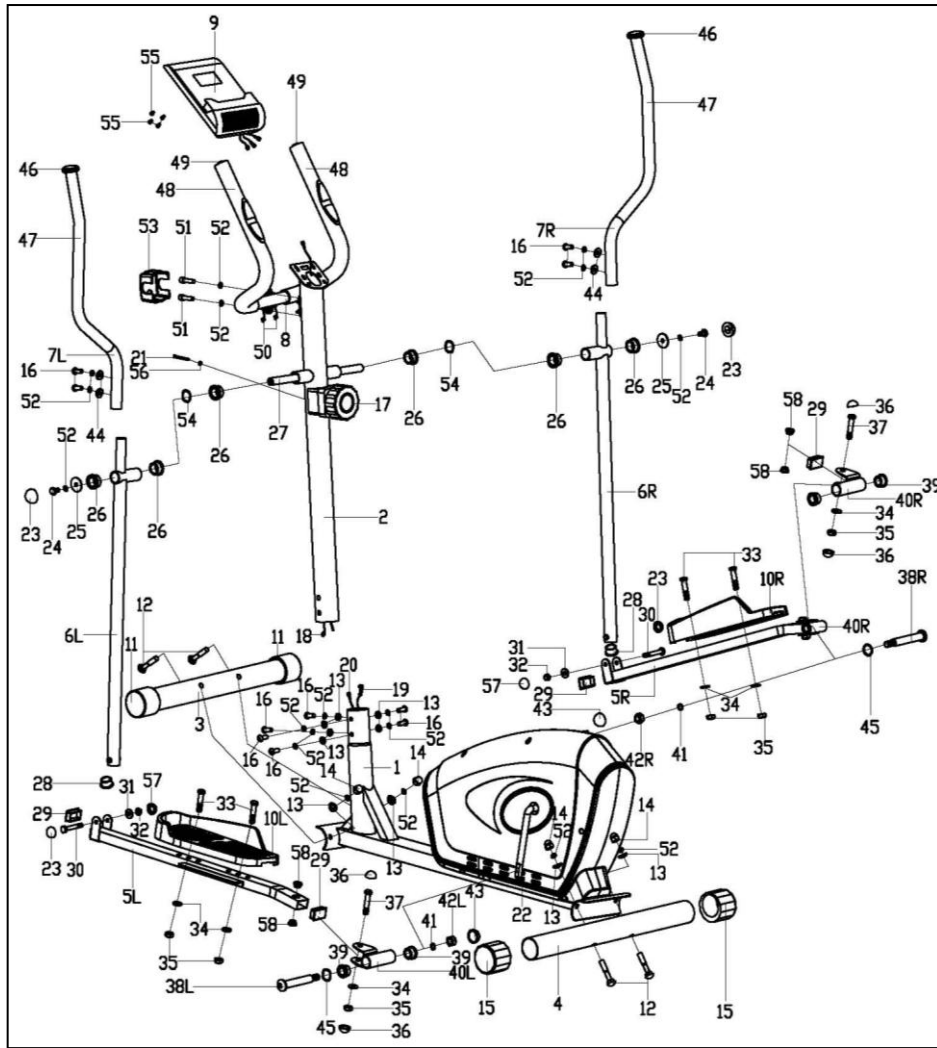

PARTS LIST

No.	Description	Spec.	Qty.
1	Main Frame		1
2	Handlebar Post		1
3	Front Stabilizer		1
4	Rear Stabilizer		1
5L/R	Pedal Support		1 pr.
6L/R	Swing Tube		1 pr.
7L/R	Handlebar		1 pr.
8	Handlebar		1
9	Computer		1
10L/R	Pedal		1 pr.
11	Front End Cap		2
12	Carriage Bolt	M8x76	4
13	Arc Washer	Φ20xΦ8.5xR30	10
14	Acorn Nut	M8	4
15	Rear End Cap		2
16	Inner Hex Bolt	M8x16	10
17	Tension Controller		1
18	Extension Wire		1
19	Tension Cable		1
20	Sensor Wire		1
21	Cross Pan Head Screw	M5x55	1
22	Crank		1
23	Cap	S14	4
24	Hex Bolt	M8x20	2
25	Flat Washer	Φ8.2xΦ32x2	2
26	Bushing	Φ32x2.5	6
27	Shaft		1
28	Round Cap	Φ32x1.5	2
29	Square Cap	□40x25x1.5	4
30	Hex Bolt	M8x55	2
31	Flat Washer	d8x1.5	2
32	Nylon Nut	M8	2
33	Hex Bolt	M10x45	4
34	Flat Washer	d10x1.5	6
35	Nylon Nut	M10	6
36	Cap	S17	4
37	Hex Bolt	M10x50	2
38L/R	Hinge Bolt	Φ16x69.5	1 pr.
39	Bushing	Φ24x20xΦ16.1	4
40L/R	Connecting Joint		1 pr.
41	Spring Washer	Φ13xB2	2
42L/R	Nylon Nut	B0.5x20	1 pr.
43	Cap	S19	2
44	Arc Washer	Φ20xd8.5xR12.5	4
45	Wave Washer	D17x0.3	2
46	End Cap		2
47	Handlebar Grip		2
48	Foam Grip		2

No.	Description	Spec.	Qty.
49	Round Cap	Φ25x1.5	2
50	Pulse Wire		2
51	Inner Hex Bolt	M8x30	2
52	Spring Washer	D8	18
53	Clamp Cover		1
54	Wave Washer	Φ20xΦ28x0.3	2
55	Cross Pan Head Screw	M4x12	4
56	Arc Washer		1
57	Cap	S13	2
58	Bushing	Φ14x10xΦ10.1	4
59	Flat Washer	D5x1	4
60	Idler		1
61	Spacer		1
62	Nylon Nut	M10	1
63	Spring		1
64	Round Cap		1
65	Conical Thin Nut	M10x1	2
66L/R	Belt Cover		1 pr.
67	Nut		2
68	Washer		1
69	Two Slot Nut		1
70	Ball Bearing		2
71	Central Bowl		2
72	Hex Bolt		1
73	Hex Screw	M5	2
74	Hex Bolt	M10x40	1
75	Hex Screw	M6	2
76	Three Slot Nut		1
77	Big Washer		1
78	Round Magnet		1
79	Belt Pulley		1
80	Belt		1
81	Cross Pan Head Screw	ST4.2x18	13
82	Hex Bolt		2
83	Spring Washer		2
84	Washer		2
85	Axle Spring Washer		2
86	Magnetic Board Axle		1
87	Square Magnet		8
88	Spring		1
89	Magnetic Board		1
90	Adjusting Belt U Mat		2
91	Flange Nut	M10x1	1
92	Adjusting Belt Bolt		2
93	Hex Thin Nut	M10x1	1
94	Conical Spacer		1
95	Bearing	6000Z	2
96	Flywheel		1

97	Flywheel Axle		1
98	Crank Cover		2
99	Spanner	S=10,13,14,15,17	1
100	Wrench	S=6	1

101	Wrench	S=8	1
102	Spanner	S=17,19	1
103	Spanner	S=13,14	1
104	Sensor Bracket		1



















Ordering Replacement Parts (U.S. and Canadian Customers only)

Please provide the following information in order for us to accurately identify the part(s) needed:

- ✓ The model number (found on cover of manual)
- ✓ The product name (found on cover of manual)
- ✓ The part number found on the “EXPLODED DIAGRAM” and “PARTS LIST” (found near the front of the manual)

Please contact us at support@sunnyhealthfitness.com or 1- 877 - 90SUNNY (877-907-8669).

HARDWARE PACKAGE

	————— #12 M8x76 4PCS		————— #13 $\Phi 20 \times \Phi 8.5 \times R30$ 4PCS
	————— #52 D8 4PCS		————— #14 M8 4PCS
	————— #33 M10x45 4PCS		————— #34 d10x1.5 4PCS
	————— #35 M10 4PCS		————— #30 M8x55 2PCS
	————— #31 d8x1.5 2PCS		————— #32 M8 2PCS
	————— #38 $\Phi 16 \times 69.5$ 2PCS		————— #41 $\Phi 13 \times B2$ 2PCS
	————— #42 B0.5*20 2PCS		————— #45 D17x0.3 2PCS
	————— #99 S=10,13,14,15,17 1PC		————— #100 S=6 1PC
	————— #101 S=8 1PC		————— #102 S=17,19 1PC
	————— #103 S=13,14 1PC		

ASSEMBLY INSTRUCTIONS

We value your experience using Sunny Health and Fitness products. For assistance with parts or troubleshooting, please contact us at support@sunnyhealthfitness.com or 1-877-90SUNNY (877-907-8669).

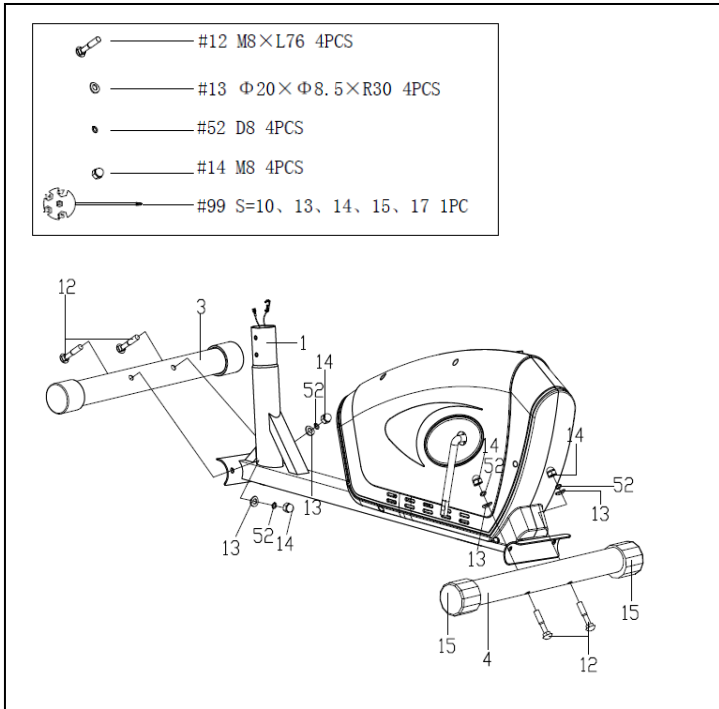

STEP 1:

Attach the **Front & Rear Stabilizers (No. 3 & 4)** to the **Main Frame (No. 1)** with 4 **Carriage Bolts (No. 12)**, 4 **Spring Washers (No. 52)**, 4 **Arc Washers (No. 13)** and 4 **Acorn Nuts (No. 14)**. Tighten and secure with **Spanner (No. 99)**.

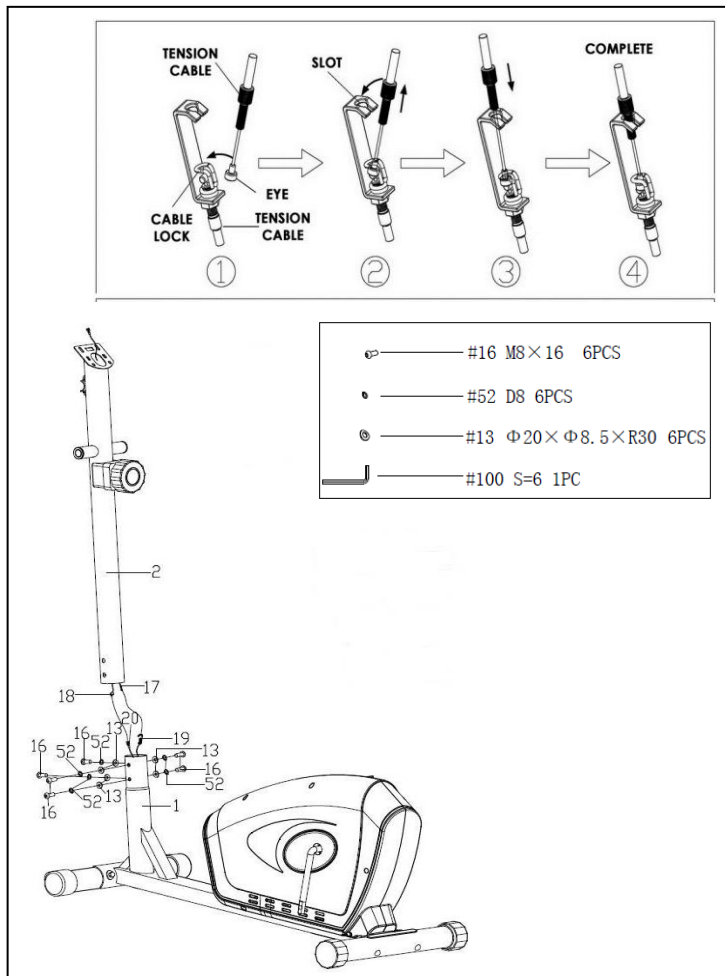

STEP 2:

Check the **Tension Controller (No. 17)** is at Level 8 (highest resistance) to ensure the cable is the longest. Connect **Extension Wire (No. 18)** to **Sensor Wire (No. 20)** then connect the cable of **Tension Controller (No. 17)** to the hook of the **Tension Cable (No. 19)** as shown in Figure A.

1. Insert eye of upper tension cable into the cable lock.
2. Pull the tension cable so that you can insert the cable into the gap at the top of the metal bracket.
3. Lower the tension cable so that it sits on the metal bracket.

Remove pre-assembled 6 **Inner Hex Bolts (No. 16)**, 6 **Spring Washers (No. 52)** and 6 **Arc Washers (No. 13)** from **Main Frame (No. 1)**, then attach the **Handlebar Post (No. 2)** to the **Main Frame (No. 1)** with 6 **Inner Hex Bolts (No. 16)**, 6 **Spring Washers (No. 52)** and 6 **Arc Washers (No. 13)** that were removed. Tighten and secure with **Wrench (No. 100)**.

NOTE: Do not completely tighten the bolts yet.

We value your experience using Sunny Health and Fitness products. For assistance with parts or troubleshooting, please contact us at support@sunnyhealthfitness.com or 1-877-90SUNNY (877-907-8669).

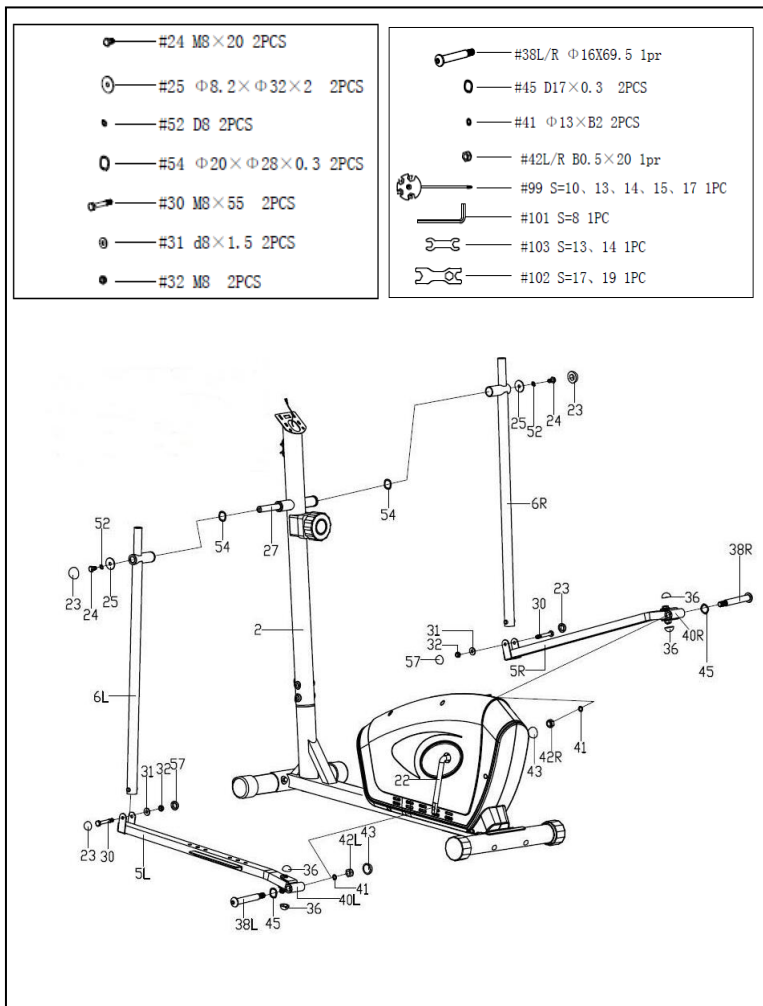

STEP 3:

Remove pre-assembled 2 **Hex Bolts (No. 24)**, 2 **Spring Washers (No. 52)**, 2 **Flat Washers (No. 25)** and 2 **Wave Washers (No. 54)** from the **Shaft (No. 27)**.

Insert the **Shaft (No. 27)** into the **Handlebar Post (No. 2)** then insert **Wave Washer (No. 54)** and attach the **Left Swing Tube (No. 6L)** to the left side of **Shaft (No. 27)**. Next, put the other end with **Flat Washer (No. 25)**, **Spring Washer (No. 52)** and **Hex Bolt (No. 24)** that were removed onto **Shaft (No. 27)** to fix the other end. Tighten and secure with **Spanner (No. 99)** and **Spanner (No. 103)**.

NOTE: Do not completely tighten the bolts yet.

CAUTION:

Hinge Bolt (No. 38) is label L or R. **Left Nylon Nut (No. 42L)** is black on the inside and **Right Nylon Nut (No. 42R)** is white on the inside.

Attach the **Left Pedal Support (No. 5L)** to the **Left Crank (No. 22)** with **Left Hinge Bolt (No. 38L)**, **Wave Washer (No. 45)**, **Spring Washer (No. 41)** and **Left Nylon Nut (No. 42L)**. Tighten and secure with **Wrench (No. 101)** and **Spanner (No. 102)**. Please note that you must turn the **Left Hinge Bolt (No. 38L)** counter-clockwise to tighten, and screw the **Left Nylon Nut (No. 42L)** clockwise onto the threaded end of the **Connecting Joint (No. 40L)**.

NOTE: Do not tighten the bolts yet.

Attach the **Left Swing Tube (No. 6L)** to the **Left Pedal Support (No. 5L)** with **Hex Bolt (No. 30)**, **Flat Washer (No. 31)** and **Nylon Nut (No. 32)** with **Spanner (No. 99)** and **Spanner (No. 103)**. Tighten **Hex Bolt (No. 24)**, **Hex Bolt (No. 30)** and **Left Nylon Nut (No. 42L)** using **Spanner (No. 99)** and **Spanner (No. 103)** and cover the bolts with **Caps (No. 23 & 57 & 43 & 36)**.

Repeat the steps above to assemble the right side, but please note that you must turn the **Right Hinge Bolt (No. 38R)** clockwise to tighten, and screw the **Right Nylon Nut (No. 42R)** counter-clockwise onto the threaded end of the **Connecting Joint (No. 40R)**.

Tighten all the **Inner Hex Bolts (No. 16)** on the **Handlebar Post (No. 2)** for step 2 using **Wrench (No. 100)**.

We value your experience using Sunny Health and Fitness products. For assistance with parts or troubleshooting, please contact us at support@sunnyhealthfitness.com or 1-877-90SUNNY (877-907-8669).

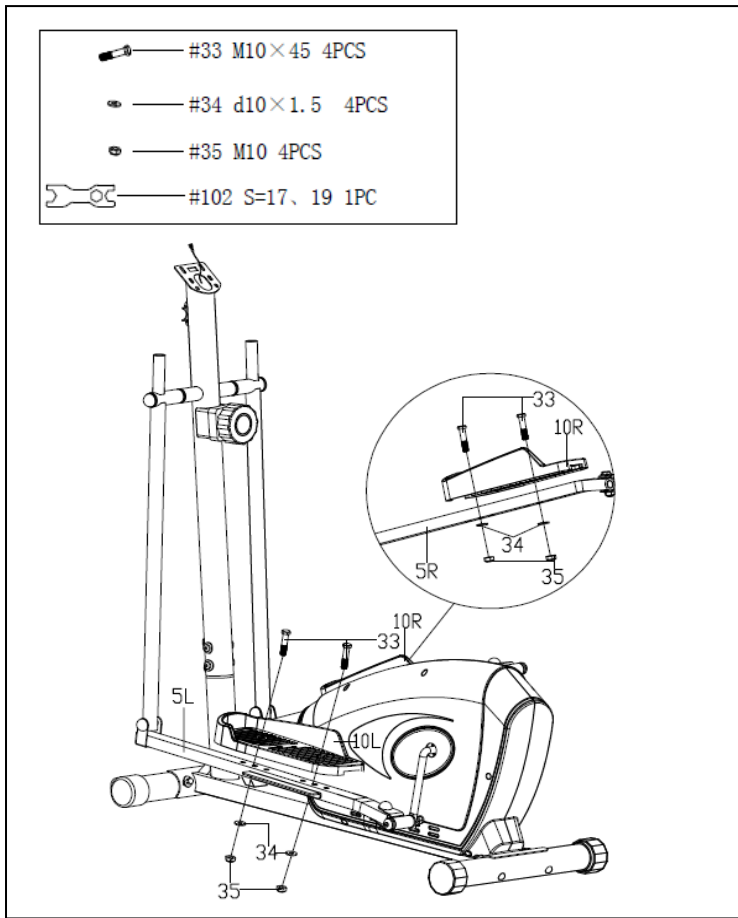

STEP 4:

Attach the 2 **Pedals (10L/R)** to the corresponding 2 **Pedal Supports (No. 5L/R)** with 4 **Hex Bolts (No. 33)**, 4 **Flat Washers (No. 34)** and 4 **Nylon Nuts (No. 35)** using **Spanner (No. 102)**.

NOTE: There are 3 positions on the **Pedal Support (No. 5L/R)**, numbered 1, 2, and 3, that you can install the **Pedals (No. 10R/L)**. Adjust the pedal position to suit your comfort level. Make sure both **Left and Right Pedals (No. 10 L/R)** are set at the same position numbers.

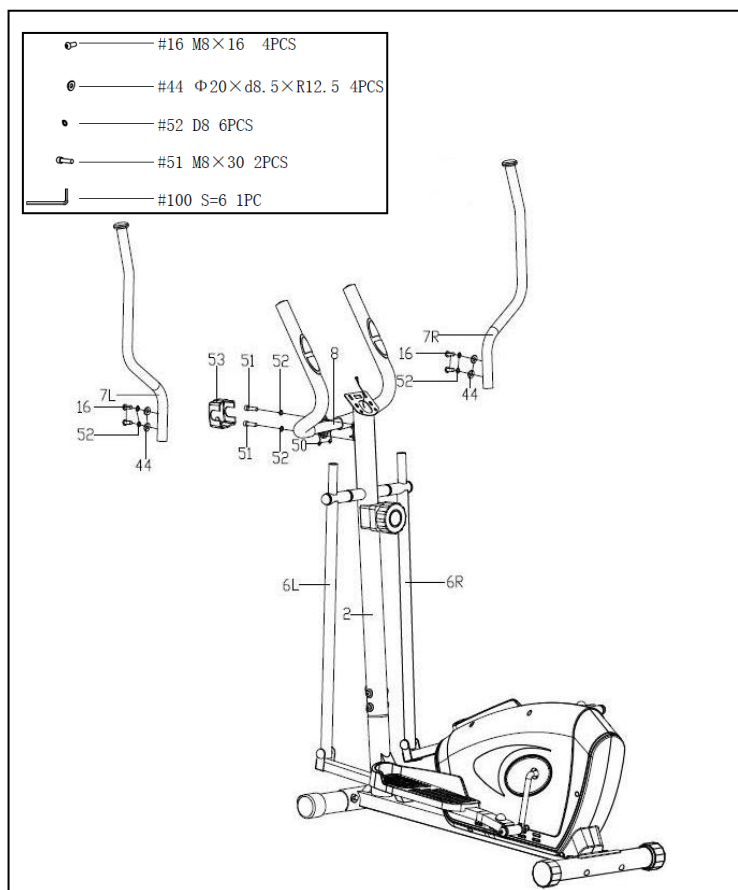

STEP 5:

Insert the **Pulse Wire (No. 50)** through the hole of **Handlebar Post (No. 2)** then pull it out from the hole of computer bracket at the top of the **Handlebar Post (No. 2)**.

Remove pre-assembled 2 **Inner Hex Bolts (No. 51)** and 2 **Spring Washers (No. 52)** from the **Handlebar (No. 8)** first. Attach **Handlebar (No. 8)** onto the **Handlebar Post (No. 2)** with 2 **Inner Hex Bolts (No. 51)** and 2 **Spring Washers (No. 52)** that were removed using **Wrench (No. 100)**. Lastly, put on the **Clamp Cover (No. 53)**.

Remove pre-assembled 4 **Inner Hex Bolts (No. 16)**, 4 **Spring Washers (No. 52)** and 4 **Arc Washers (No. 44)** from the **Swing Tubes (No. 6L/R)**. Attach the 2 **Handlebars (No. 7L/R)** to the corresponding **Swing Tubes (No. 6L/R)** and secure them with 4 **Inner Hex Bolts (No. 16)**, 4 **Spring Washers (No. 52)** and 4 **Arc Washers (No. 44)** using **Wrench (No. 100)**.

We value your experience using Sunny Health and Fitness products. For assistance with parts or troubleshooting, please contact us at support@sunnyhealthfitness.com or 1-877-90SUNNY (877-907-8669).

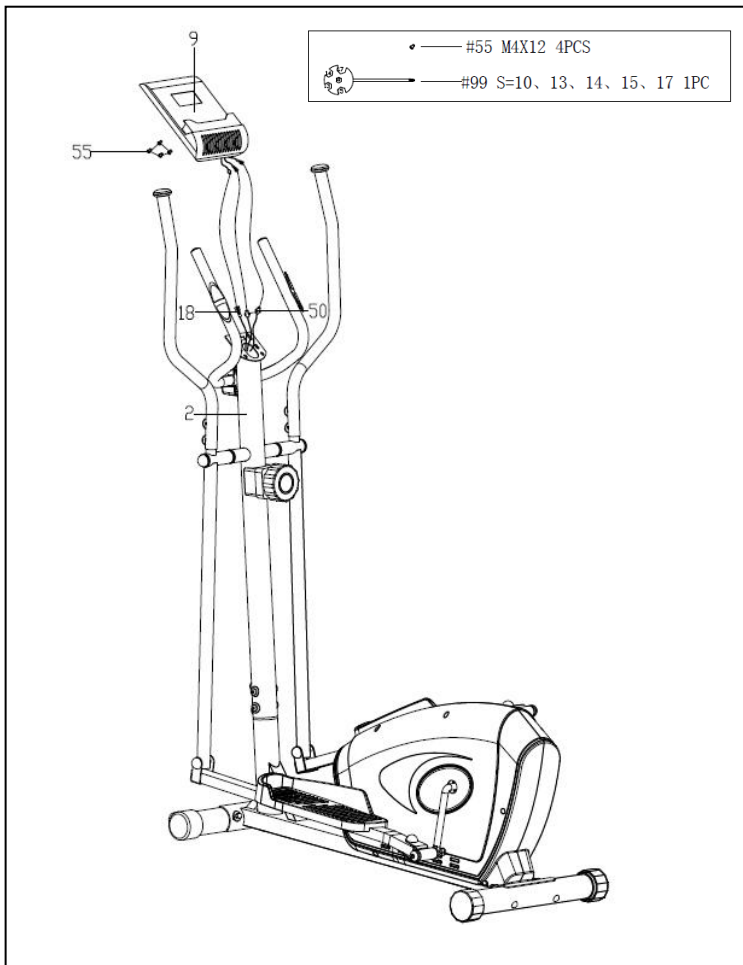

STEP 6:

Remove pre-assembled 4 **Cross Pan Head Screws (No. 55)** from the back of the **Computer (No. 9)**. Connect **Extension Wire (No. 18)** and 2 **Pulse Wires (No. 50)** to the relevant wires of the **Computer (No. 9)**. Attach the **Computer (No. 9)** to the computer bracket of **Handlebar Post (No. 2)** with 4 **Cross Pan Head Screws (No. 55)** using **Spanner (No. 99)**.

Now, make sure you completely tighten all the bolts and screws from the previous steps.

The assembly is complete!

ADJUSTMENTS & USAGE GUIDE

1. If you find there is no difference between tension level 1 to level 8, check the connection of the tension cable. See Diagram below.

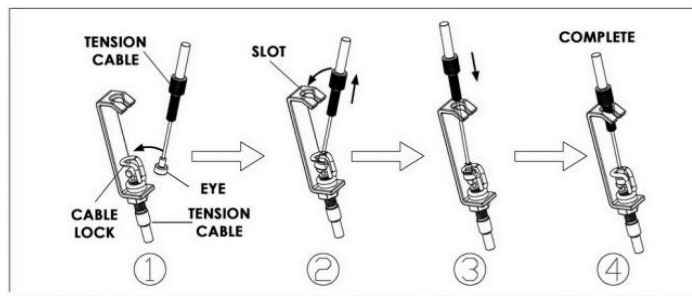

2. If the computer does not show numbers correctly, check the batteries. If the computer does not count the speed and time, check the connections of **Extension Wire (No. 18)** to the **Computer (No. 9)** and **Extension Wire (No. 18)** to **Sensor Wire (No. 20)**.
3. If you have difficulty putting **Hinge Bolts (No. 38L/R)** into the **Crank (No. 22)**, try moving the **Crank (No. 22)** to a different angle. Keep in mind the **Left Hinge Bolt (No. 38L)** has reverse threading and must be installed by turning counter-clockwise.
4. If you hear any noise when using the machine, please check if **Hinge Bolts (No. 38L/R)**, **Hex Bolt (No. 30)**, **Hex Bolt (No. 24)** and **Connecting Joint (No. 40)** are loose. You may remove these parts and add some lubricant oil to eliminate all noise possibilities, remember to tighten all the parts securely.
5. When you first use the machine, if you hear any unusual noises from the inside of the **Belt Cover (No. 66L/R)**, please loosen the screws on the chain cover about two rotations, then push the **Belt Cover (No. 66L/R)** up a little bit; finally, fasten the screws you loosened before. See the following diagram. (During shipping, the **Belt Cover (No. 66L/R)** can be dislocated, and the **Flywheel (No. 96)** may rub on the **Belt Cover (No. 66L/R)**).

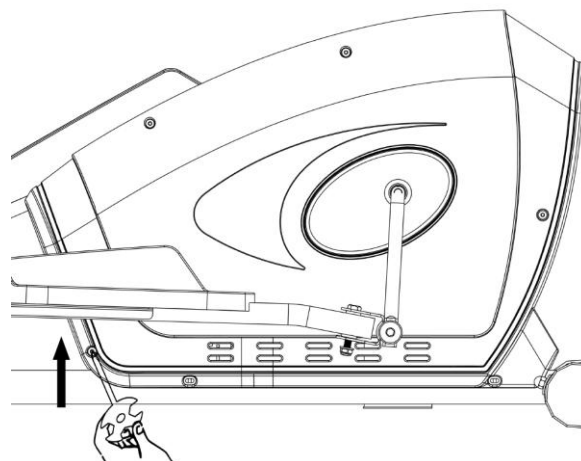

6. If it is very hard to pedal on the higher tension levels, or you hear rubbing noises, please remove the **Belt Cover (No. 66L/R)**, and adjust the screw seen in the following diagram. You will need to lower the position of the screw by turning counter-clockwise; this will keep the **Magnetic Board (No. 89)** from contacting the magnetic flywheel. Before re-installing the **Belt Cover (No. 66L/R)**, test the tension level 8 to ensure the magnets do not touch the flywheel.

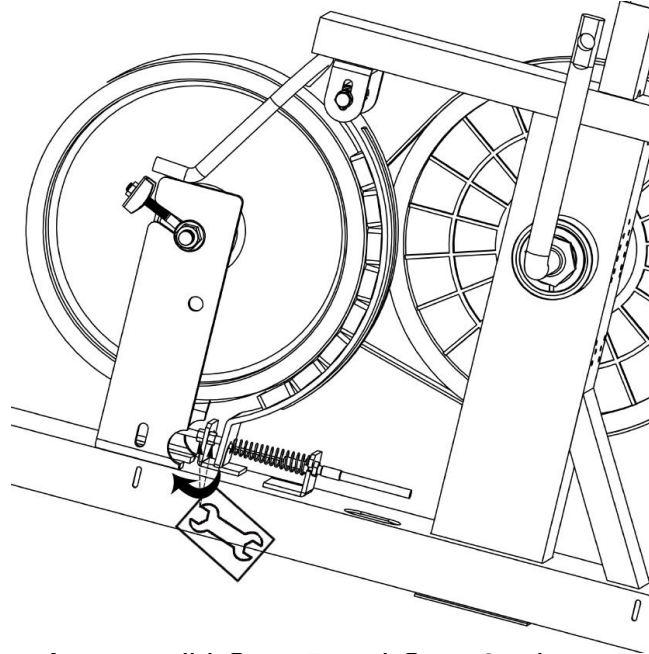

7. If you still hear noises after you did Step 5 and Step 6, please remove the **Belt Cover (No. 66L/R)**; loosen the screws for the **Flywheel (No. 96)** about a half of a rotation. See the following diagram.

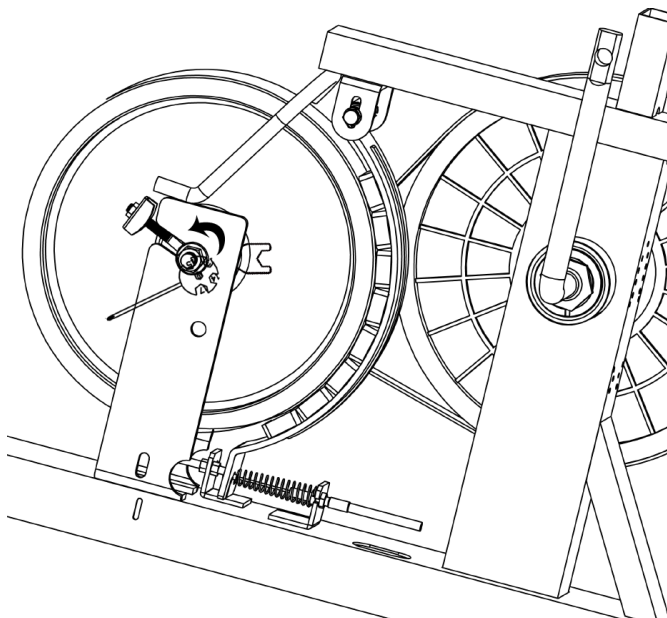

8. If you feel the machine is uneven, please adjust the **Rear End Cap (No. 15)** on **Real Stabilizer (No. 4)** by turning it. If the machine is wobbly when you use it, please consider adding an exercise mat under it.

BATTERY INSTALLATION & REPLACEMENT

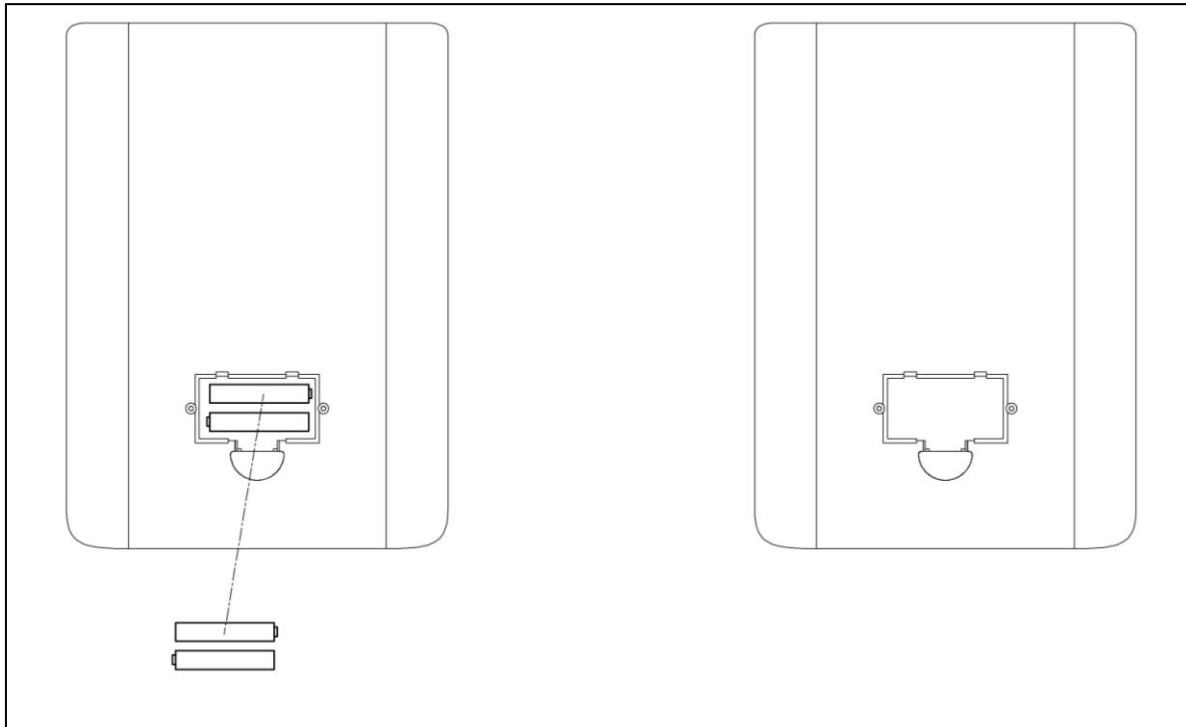

BATTERY INSTALLATION:

The computer uses 2 AA batteries. Open the battery cover from the back of the computer, then put 2 batteries into the battery compartment. Make sure the (+) and (-) ends of the batteries are in the correct position. Put the battery cover back.

BATTERY REPLACEMENT:

If there is a problem with the display, try changing the batteries first. Open the battery cover, remove the old batteries and replace with new batteries. Make sure the (+) and (-) ends of the batteries are in the correct position. Put the battery cover back.

When changing batteries, always replace both with new batteries. Do not mix old and new batteries.

EXERCISE COMPUTER

SPECIFICATIONS:

TIME.....	00:00-99:59 MIN:SEC
SPEED.....	0.0-999.9 MPH
DISTANCE.....	0.00-99.99 MILES
CALORIES.....	0.0-999.9 KCAL
ODOMETER.....	0.0-9999 MILES
PULSE.....	40-240 BPM

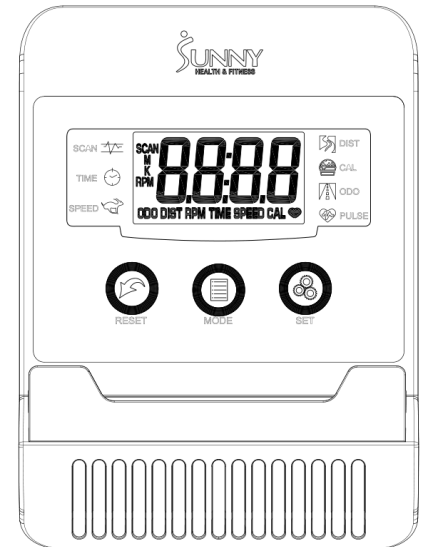

FUNCTION KEY:

MODE: Press to select function.

RESET: Press to reset the value back to zero.

SET: Press to preset the desired countdown of TIME, DISTANCE, or CALORIES.

OPERATION PROCEDURES:

1. AUTO ON/OFF:

If the elliptical is put into motion or the **MODE** button is pressed, the computer will turn on. After 4 minutes of inactivity, the computer will turn off.

2. RESET:

The computer can be reset by pressing and holding the **MODE** button for three seconds. Removing the batteries will also reset the computer and change all function values back to zero.

3. MODE:

To select the LOCK MODE setting press the **MODE** key when the pointer on the function you wish to select begins to blink (once locked only the selected function will be displayed).

4. FUNCTIONS:

TIME: Counts the total time of an exercise session from start to finish.

SPEED: Displays the current speed.

DISTANCE: Counts the total distance of an exercise session from start to finish.

CALORIES: Counts the total amount of calories burned during an exercise session from start to finish.

ODOMETER: Counts the total distance traveled from all workout sessions.

PULSE: Displays the user's current heart rate in beats per minute.

Place the palms of your hands on both of the pulse sensors, the computer will display your current heart beat rate on the computer. (This value is not intended for medical use)

SCAN: Automatically displays all functions repeatedly.

Battery: The computer uses 2 AA batteries, which are packed with the computer box. Dispose the batteries according to the laws and regulations of your local region. Some batteries may be recycled. When disposing or recycling, do not mix battery types.

CONNECT WITH US

FOR FITNESS
ARTICLES, VIDEOS
& WORKOUTS



@SUNNYHEALTHANDFITNESS



@SUNNYHEALTHFITNESS



@SUNNYHEALTHFIT



/SUNNYHEALTHFITNESS



/SUNNYHEALTHANDFITNESS

WWW.SUNNYHEALTHFITNESS.COM