

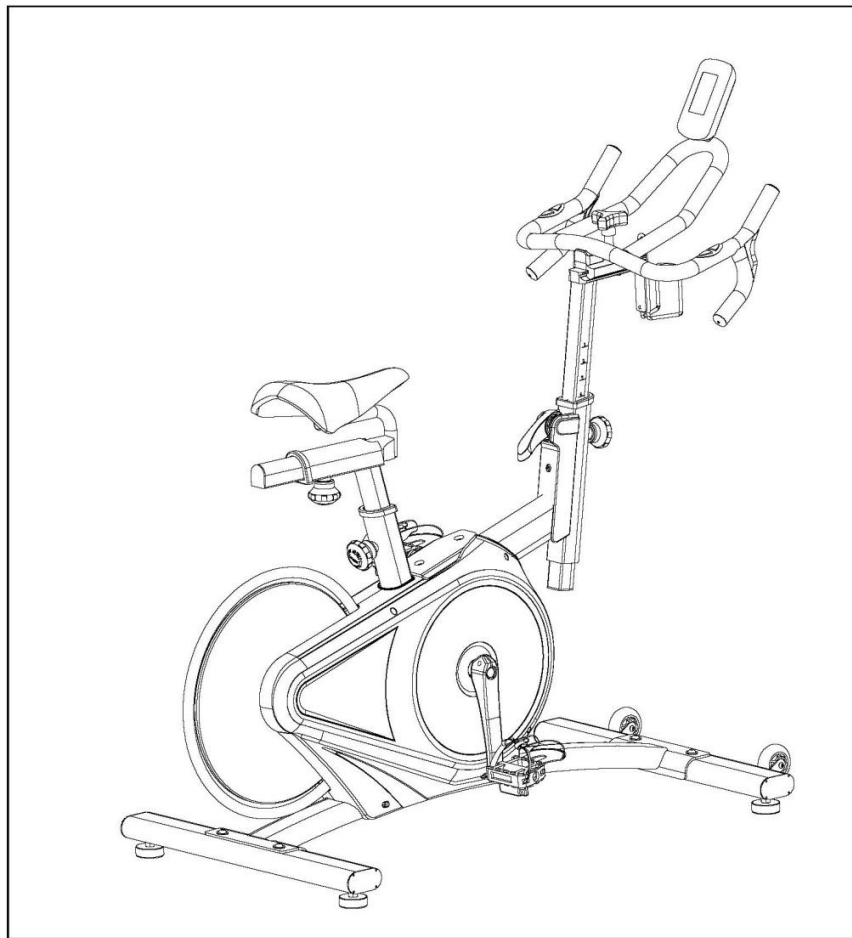

BELT DRIVE MAGNETIC INDOOR CYCLING BIKE

SF-B1709

USER MANUAL



IMPORTANT! Please retain owner's manual for maintenance and adjustment instructions. Your satisfaction is very important to us, **PLEASE DO NOT RETURN UNTIL YOU HAVE CONTACTED US:** support@sunnyhealthfitness.com or 1-877-90SUNNY (877-907-8669).



WWW.SUNNYHEALTHFITNESS.COM

IMPORTANT SAFETY INFORMATION







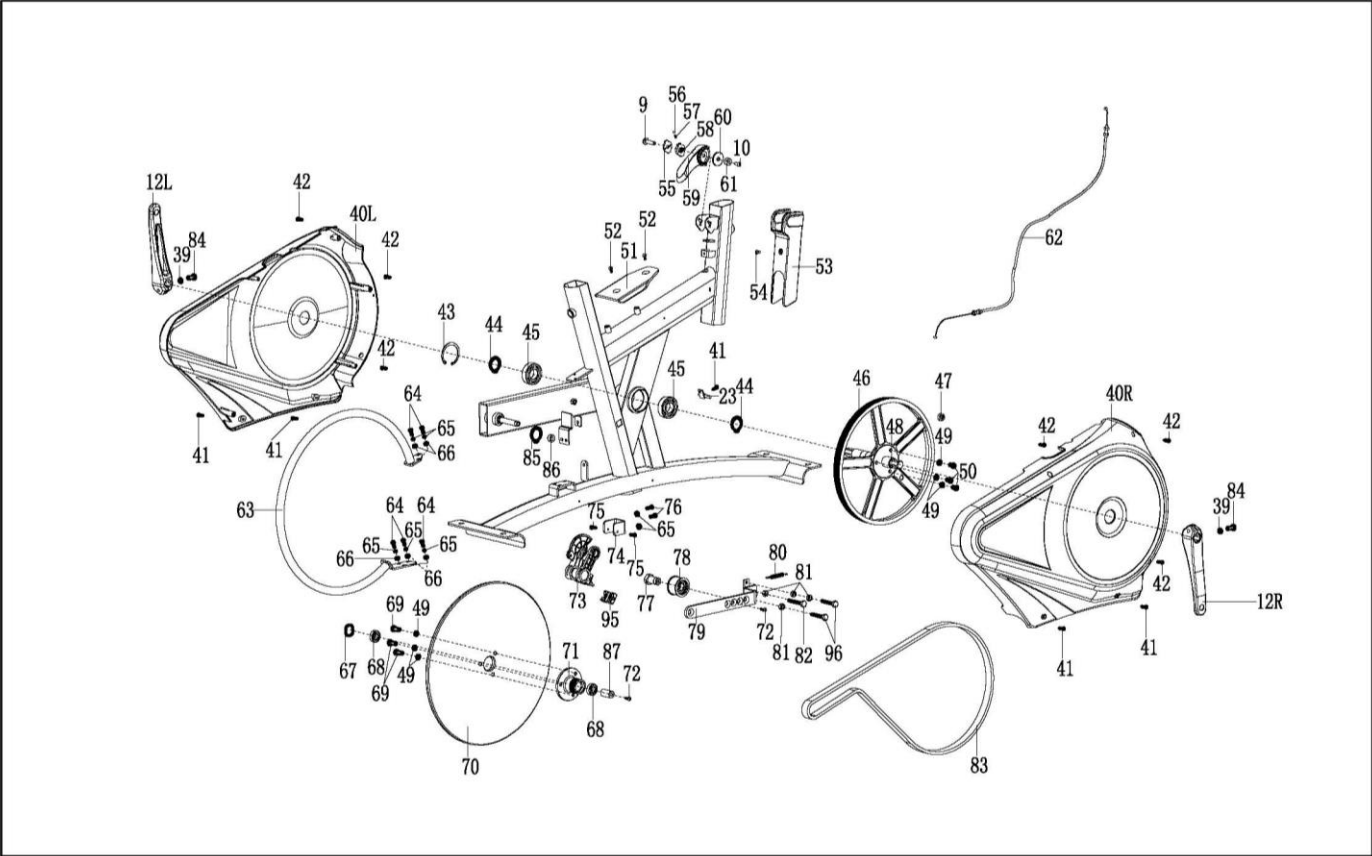





We thank you for choosing our product. To ensure your safety and health, please use this equipment correctly. It is important to read this entire manual before assembling and using the equipment. Safe and effective use can only be achieved if the equipment is assembled, maintained and used properly. It is your responsibility to ensure that all users of the equipment are informed of all warnings and precautions.

1. Before starting any exercise program, you should consult your physician to determine if you have any medical or physical conditions that could put your health and safety at risk, or prevent you from using the equipment properly. Your physician's advice is essential if you are taking medication that affects your heart rate, blood pressure or cholesterol level.
2. Be aware of your body's signals. Incorrect or excessive exercise can damage your health. Stop exercising if you experience any of the following symptoms: pain, tightness in your chest, irregular heartbeat, shortness of breath, lightheadedness, dizziness or feelings of nausea. If you do experience any of these conditions, you should consult your physician before continuing with your exercise program.
3. Keep children and pets away from the equipment. The equipment is designed for adult use only.
4. Use the equipment on a solid, flat level surface with a protective cover for your floor or carpet. To ensure safety, the equipment should have at least 2 feet (60 CM) of free space all around it.
5. Ensure that all nuts and bolts are securely tightened before using the equipment. The safety of the equipment can only be maintained if it is regularly examined for damage and/or wear and tear.
6. Always use the equipment as indicated. If you find any defective components while assembling or checking the equipment, or if you hear any unusual noises coming from the equipment during exercise, discontinue use of the equipment immediately and do not use until the problem has been rectified.
7. Wear suitable clothing while using the equipment. Avoid wearing loose clothing that may become entangled in the equipment.
8. Do not place fingers or objects into the moving parts of the equipment.
9. The maximum weight capacity of this unit is 300 pounds (135 KG).
10. The equipment is not suitable for therapeutic use.
11. To avoid bodily injury and/or damage to the product or property, proper lifting and moving is required.
12. Your product is intended for use in cool, dry conditions. You should avoid storage in extreme cold, hot or damp areas as this may lead to corrosion and other related problems.
13. This equipment is designed for indoor and home use only, it is not intended for commercial use!

EXPLODED DIAGRAM 2

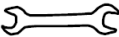

HARDWARE PACKAGE

	#6 M10 2PCS		#5 2PCS
	#13 M16X1.5X18 3PCS		#29 M5X12 2PCS
	#28 17.2XΦ22 1PC		#86 S5 1PC
	#87 S6 1PC		#94 S4 1PC
	#89 S13,15 1PC		#88 S17,19 1PC
	#93 D8XΦ20*2 1PC		
	#26 1PC		

PARTS LIST

No.	Description	Spec.	Qty.
1	Main Frame		1
2	Front Stabilizer		1
3	Rear Stabilizer		1
4	Handlebar Post		1
5	Adjusting Pad		4
6	Hex Nut	M10	4
7	Flat Washer	d10XΦ20X2	4
8	Hexagon Socket Head Screw	M10X25	4
9	Hexagon Socket Head Screw	M8X30	3
10	Hexagon Socket Head Screw	M6X12	3
11	Transportation Wheel		2
12L/R	Crank		1 pr.
13	Spring Knob	M16*1.5*18	3
14	Sleeve		3
15L/R	Refer to #97L/R		-
16	Brake Handle		1
17	D Shape Plug		1
18	Seat Post		1
19	D Shape Plug		1
20	Seat Horizontal Tube		1
21	Seat		1
22	Handlebar		1
23	Sensor Wire		1
24	Extension Wire 1		1
25	Pulse Wire		1
26	Triangle Knob		1
27	Sliding Block		1
28	Bolt	17.2XΦ22	1
29	Hexagon Socket Cap Screw	M5X12	2
30	Bracket		1
31	Cross Head Screw	M5X8	2
32	Flat Washer	Φ5XΦ10X1	2

No.	Description	Spec.	Qty.
33	Bottle Holder		1
34	Meter		1
35	Shipping Tube		2
36	Hexagon Socket Cap Screw	M8X16	2
37	Extension Wire 2		1
38	Hexagon Socket Cap Screw	M6X10	1
39	Flat Washer	Φ8XΦ12X1	2
40L/R	Belt Cover		1 pr.
41	Cross Head Self Tapping Screw		5
42	Screw		6
43	Closing Ring	d52	1
44	Axle Ring	d25	2
45	Bearing		2
46	Belt Pulley		1
47	Round Magnet		1
48	Center Axle		1
49	Spring Washer	D8	6
50	Hexagon Socket Head Screw	M8X12	3
51	Foot Plate		1
52	Inner Hexagon Countersunk Head Screw	M8X12	2
53	Brake Cover		1
54	Screw	M5X10	1
55	Stop Block		1
56	Ball		1
57	Compressed Spring		1
58	Stop Block		1
59	Brake Handle		1
60	Block		1
61	Spacer		1
62	Tension Wire		1
63	Steel Ring		1
64	Hex Bolt	M6X16	5

65	Spring Washer	D6	7
66	Washer	D6XΦ12X1.2	5
67	Wave Washer	D12XΦ18X0.3	1
68	Bearing		2
69	Hexagon Socket Head Screw	M8X20	3
70	Flywheel		1
71	Sleeve		1
72	Inner Hexagon Countersunk Head Screw	M8X25	2
73	Brake Block		1
74	U Shape Block		1
75	Cross Countersunk Head Screw	M6X16	2
76	Hex Bolt	M6X12	2
77	Axle		1
78	Idler Wheel		1
79	Supporting Board		1
80	Spring		1
81	Hex Screw	M8	3

82	Hex Bolt	M8X50	1
83	Belt		1
84	Bolt	M8X18	4
85	Stop Ring	D12	1
86	Allen Wrench	S5	1
87	Allen Wrench	S6	1
88	Wrench	S=17-19	1
89	Wrench	S=13-15	1
90	Spacer		1
91	Flywheel Spacer		1
92	Square Plug		4
93	Washer	D8XΦ20X2	1
94	Allen Wrench	S4	1
95	Rubber Cushion		1
96	Hex Bolt	M8X40	2
97L/R	Pedal		1 pr.
98L/R	Nylon Nut	9/16	1 pr.

Ordering Replacement Parts (U.S. and Canadian Customers only)

Please provide the following information in order for us to accurately identify the part(s) needed:

- ✓ The model number (found on cover of manual)
- ✓ The product name (found on cover of manual)
- ✓ The part number found on the “EXPLODED DIAGRAM” and “PARTS LIST” (found near the front of the manual)

Please contact us at support@sunnyhealthfitness.com or 1- 877 – 90SUNNY (877-907-8669).

ASSEMBLY INSTRUCTIONS

We value your experience using Sunny Health and Fitness products. For assistance with parts or troubleshooting, please contact us at support@sunnyhealthfitness.com or 1-877-90SUNNY (877-907-8669).

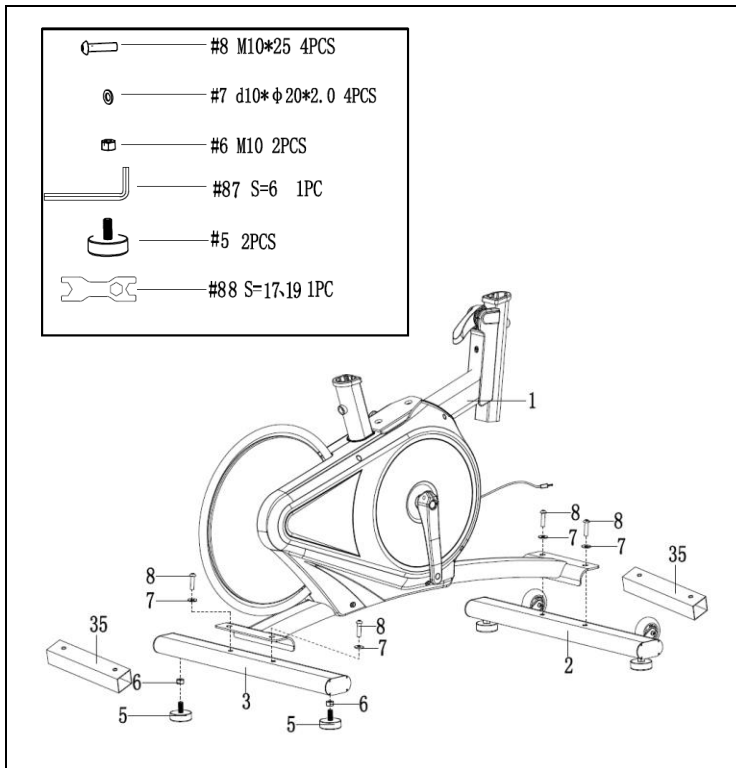

STEP 1:

Attach 2 **Adjusting Pads (No. 5)** and 2 **Hex Nuts (No. 6)** to the **Rear Stabilizer (No. 3)** by using **Wrench (No. 88)**.

Unscrew the preassembled 4 **Hexagon Socket Head Screws (No. 8)** with **Allen Wrench (No. 87)**. Then remove the 4 **Flat Washers (No. 7)** and 2 **Shipping Tubes (No. 35)** from the **Main Frame (No. 1)**.

Attach the **Front & Rear Stabilizer (No. 2 & No. 3)** to the **Main Frame (No. 1)** using 4 **Hexagon Socket Head Screws (No. 8)**, 4 **Flat Washers (No. 7)** that were just removed. Tighten and secure with the **Allen Wrench (No. 87)**.

NOTE: You can discard the **Shipping Tubes (No. 35)** or save them for future packaging or transportation.

STEP 2:

IMPORTANT! Read instructions carefully. Failure to follow instructions may cause permanent damage to your bike.

Remove the **Left & Right Nylon Nuts (No. 98L/R)** located on the **Pedals (No. 97L/R)**. The **Right Nylon Nut (No. 98R)** is white on the inside. The **Left Nylon Nut (No. 98L)** is blue on the inside.

Screw the **Left Pedal (No. 97L)** **COUNTER-CLOCKWISE** into the **Left Crank (No. 12L)** by using the **Wrench (No. 89)**. Once it is properly screwed into the place, use the **Wrench (No. 89)** to hold the bolt of the pedal and screw the **Left Nylon Nut (No. 98L)** **CLOCKWISE** to the thread end of the **Left Pedal (No. 97L)** securely with **Wrench(No. 88)**.

Screw the **Right Pedal (No. 97R)** **CLOCKWISE** into the **Right Crank (No. 12R)** by using the **Wrench (No. 89)**. Once properly screwed into the place, use the **Wrench (No. 89)** to hold the bolt of the pedal and screw the **Right Nylon Nut (No. 98R)** **COUNTER-CLOCKWISE** to the thread end of the **Right Pedal (No. 97R)** securely

6 with **Wrench (No. 88)**.

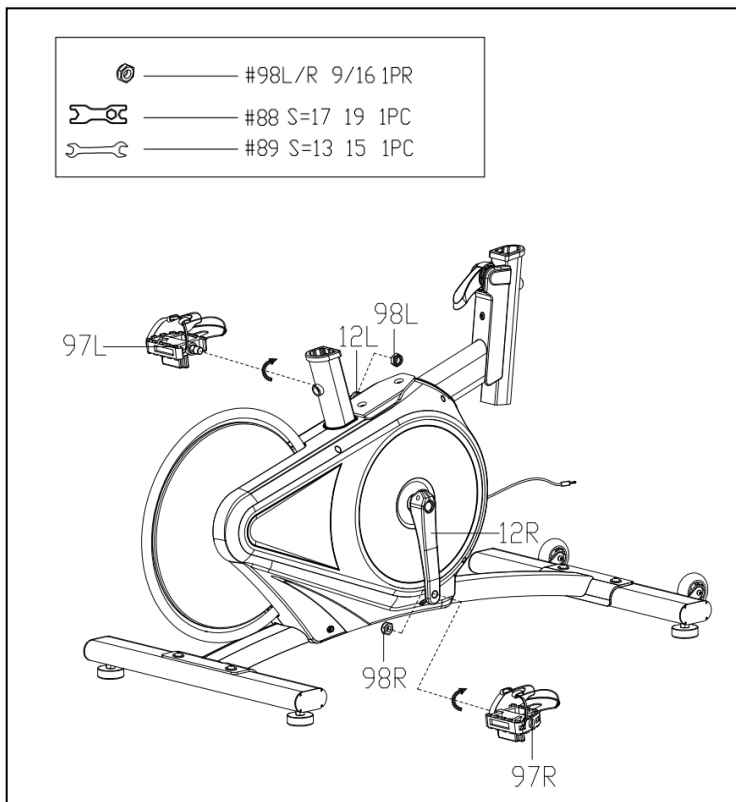

We value your experience using Sunny Health and Fitness products. For assistance with parts or troubleshooting, please contact us at support@sunnyhealthfitness.com or 1-877-90SUNNY (877-907-8669).

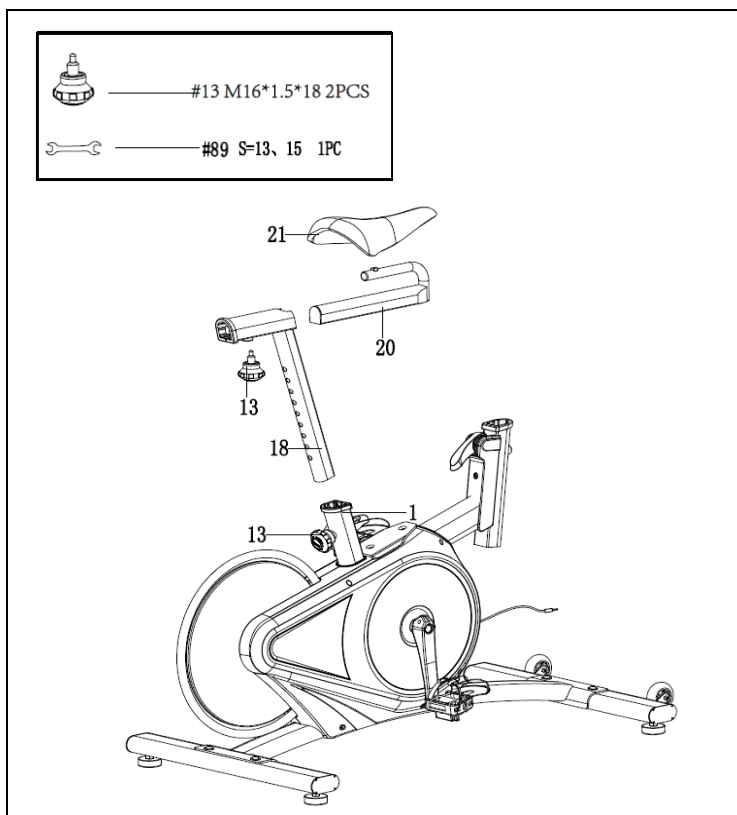

STEP 3:

Insert the **Seat Post (No. 18)** into the **Main Frame (No. 1)**. Set **Seat Post (No. 18)** at desired height. Insert **Spring Knob (No. 13)** and tighten to secure.

Insert the **Seat Horizontal Tube (No. 20)** into the **Seat Post (No. 18)**. Set **Seat Horizontal Tube (No. 20)** at desired position. Insert **Spring Knob (No. 13)** and tighten to secure.

ASSEMBLING THE SEAT

1. Use **Wrench (No. 89)** to loosen the 2 nuts (B & C) on the **Seat (No. 21)**. The round side of the seat clamp (A) should be horizontal and on the bottom. If it is not on the bottom, turn the seat clamp (A), so the round side is on the bottom. If the seat clamp (A) does not fit on the **Seat Horizontal Tube (No. 20)**, loosen the 2 nuts (B & C) some more. (Figure 1)

2. Slide the **Seat (No. 21)** onto the **Seat Horizontal Tube (No. 20)**. The points on the front edge of the seat clamp (A) will go into the indentations (D) on the **Seat Horizontal Tube (No. 20)**, and the V-shaped stopper at the end of the seat clamp (A) will be in contact with the back edge of the **Seat Horizontal Tube (No. 20)**. (Figure 2)

3. Use **Wrench (No. 89)** to tighten the 2 nuts (B & C) on the **Seat (No. 21)**. Adjust the **Seat (No. 21)** so that it is leveled and not tilted forward or backward. Continue tightening the 2 nuts (B & C).

4. Use your hand to try to move the **Seat (No. 21)** forward, backward, and side to side to test if it is secured. If the **Seat (No. 21)** moves, tighten the nuts (B & C) until the **Seat (No. 21)** does not move. (Figure 3)

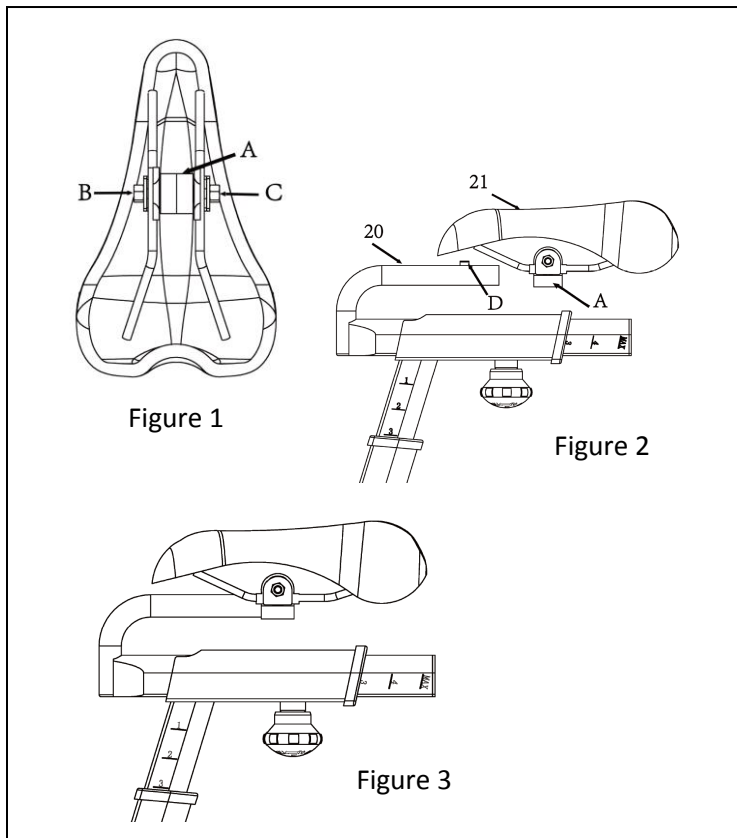

We value your experience using Sunny Health and Fitness products. For assistance with parts or troubleshooting, please contact us at support@sunnyhealthfitness.com or 1-877-90SUNNY (877-907-8669).

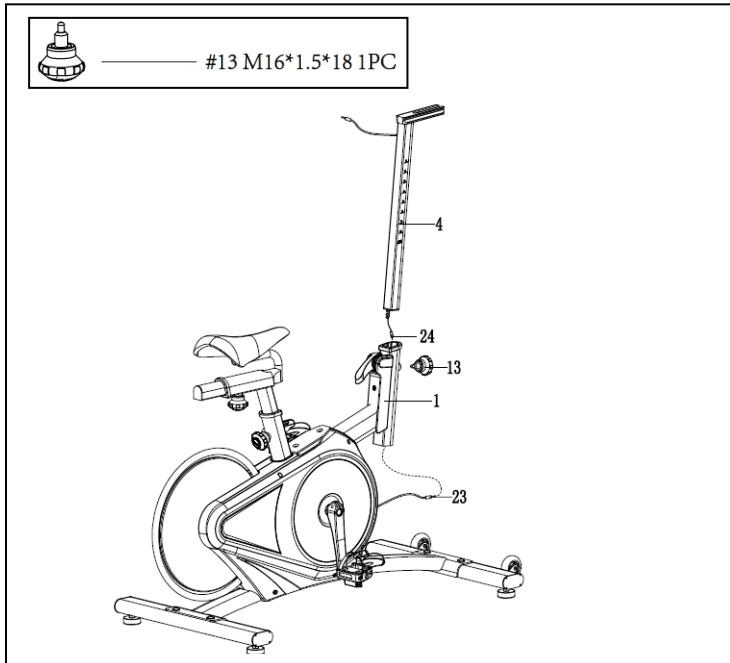

STEP 4:

Thread **Extension Wire 1 (No. 24)** into **Main Frame (No. 1)**. Insert **Handlebar Post (No. 4)** into **Main Frame (No. 1)** and set at suitable height. Then insert **Spring Knob (No. 13)** and tighten to secure. Finally connect **Extension Wire 1 (No. 24)** to **Sensor Wire (No. 23)**.

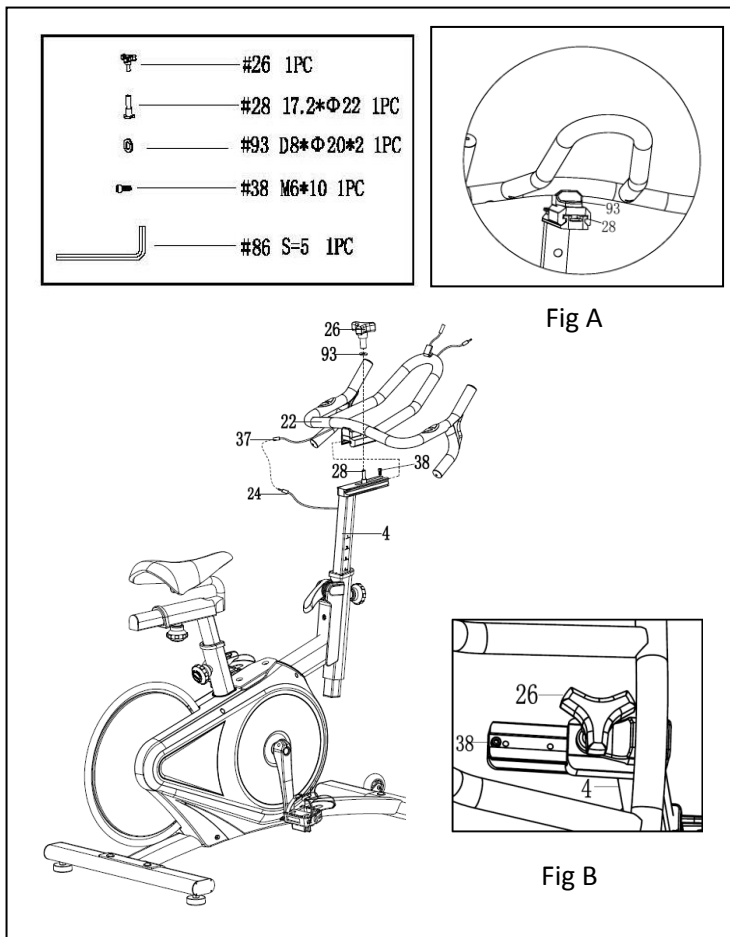

STEP 5:

Remove **Hexagon Socket Cap Screw (No. 38)** from **Handlebar Post (No. 4)** using **Allen Wrench (No. 86)**. Unscrew preassembled **Bolt (No. 28)** and **Washer (No. 93)** from **Triangle Knob (No. 26)**. Place **Handlebar (No. 22)** on **Handlebar Post (No. 4)**. Do not slide all the way on yet.

Insert **Bolt (No. 28)** into the hole in the **Handlebar (No. 22)** from the bottom. Hold **Bolt (No. 28)** on the threaded end to keep it in place while you slide the **Handlebar (No. 22)** onto the **Handlebar Post (No. 4)**. Make sure the head of **Bolt (No. 28)** fits into the groove in the **Handlebar Post (No. 4)** (See Fig A). Now slide the **Handlebar (No. 22)** all the way in.

Put **Washer (No. 93)** and **Triangle Knob (No. 26)** on **Bolt (No. 28)**. Then turn the **Triangle Knob (No. 26)** to tighten. Put **Hexagon Socket Cap Screw (No. 38)** into the hole in the **Handlebar Post (No. 4)** (See Fig B), and tighten using **Allen Wrench (No. 86)**.

Finally connect the **Extension Wire 1 (No. 24)** and **Extension Wire 2 (No. 37)**.

We value your experience using Sunny Health and Fitness products. For assistance with parts or troubleshooting, please contact us at support@sunnyhealthfitness.com or 1-877-90SUNNY (877-907-8669).

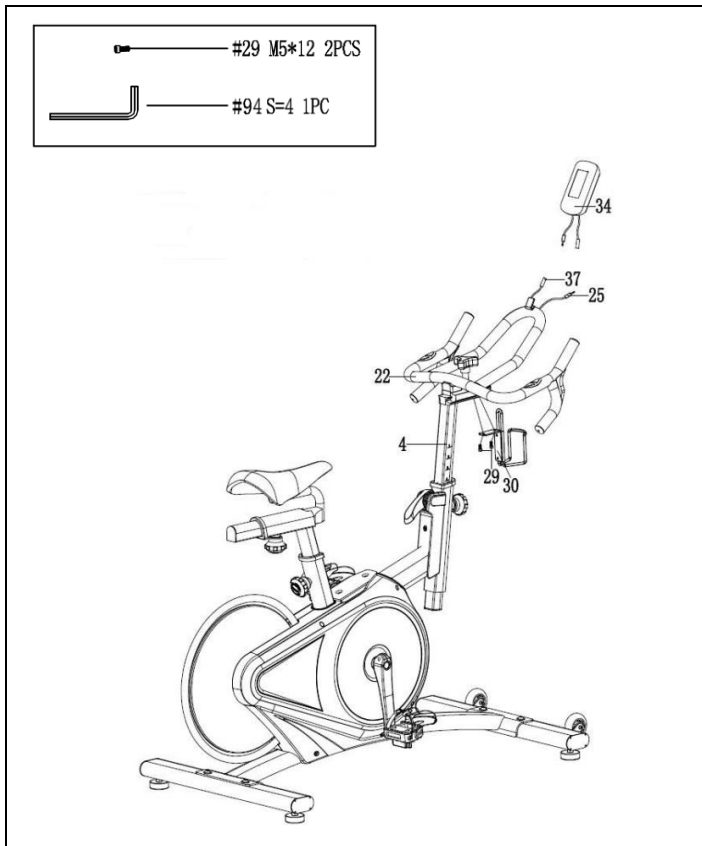

STEP 6:

Attach the **Bracket (No. 30)** to the **Handlebar Post (No. 4)** with 2 **Hexagon Socket Cap Screws (No. 29)** using **Allen Wrench (No. 94)**.

Connect the **Extension Wire 2 (No. 37)** and **Pulse Wire (No. 25)** with wires from the **Meter (No. 34)**, then attach the **Meter (No. 34)** to the **Handlebar (No. 22)**.

Assembly is complete!

SPD TECHNICAL SERVICE INSTRUCTIONS

Caution!

Before use, read these instructions carefully.

- Practice engaging and disengaging from the pedals several times in a stationary position before riding.
- Before using, lubricate the concave area of the clip.
- Keep the cleat and pedal clean to ensure proper usage.
- Before using, adjust the retention force of the pedal to suit your needs.

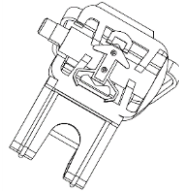

Note:

1. After tightening the cleat, practice engaging and releasing one shoe at a time.
2. Check your pedals each time before you ride the bike.
3. When the pedal starts to wear on the axle, it will not function properly. We recommend you replace the entire pedal.

USE

Engaging

Press the cleat into the pedal.

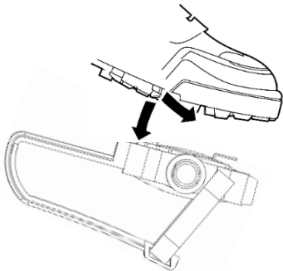

Disengaging

Remove by twisting your heel to the outside.

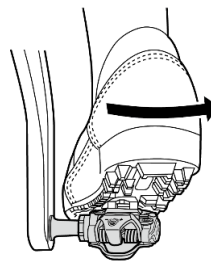

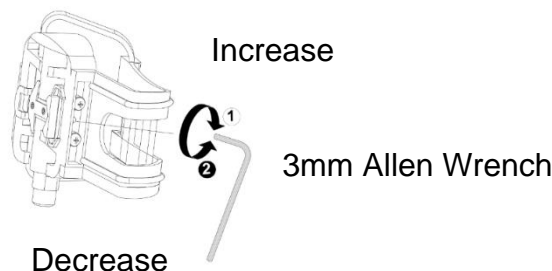

ADJUSTING THE SPRING TENSION OF THE BINDING

The tension of the spring is adjusted for each pedal (top & bottom) with the adjustment bolt in the rear using a 3mm Allen Wrench. Turn the bolt in a *clockwise* direction to increase retention force. Turn the bolt in a *counter-clockwise* direction to decrease retention force.

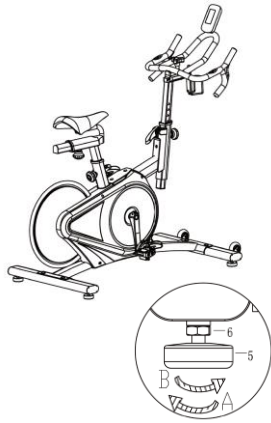

ADJUSTMENTS GUIDE



 #88 S=17.19 IPC

ADJUSTING THE BALANCE

In order to achieve a smooth and comfortable ride, you must ensure that the stability of the bike is secured. If you notice that the bike is unbalanced during use, you should adjust the foot levelers located beneath the front and rear stabilizers. To do so, use the **Wrench (No. 88)** to loosen **Hex Nut (No. 6)** by turning it *clockwise* (direction A). With the screw loosened, rotate **Adjusting Pad (No. 5)** until it sits level with the surface that the bike is on. When you have finished adjusting the **Adjusting Pad (No. 5)**, use the **Wrench (No. 88)** to re-tighten the **Hex Nut (No. 6)** by turning it *counter-clockwise* (direction B). If required, repeat this process to adjust the remaining feet.

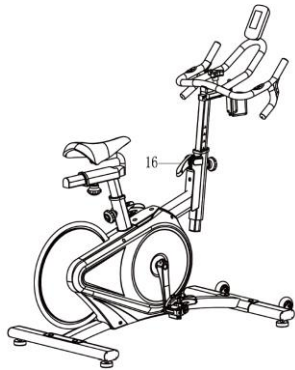

ADJUSTING THE RESISTANCE

Adjust the resistance of the bike using the **Brake Handle (No. 16)**. Increase the level of resistance by pressing the **Brake Handle (No. 16)** downward, decrease the level of resistance by pressing the **Brake Handle (No. 16)** upward. Push down on the **Brake Handle (No. 16)** for emergency brake.

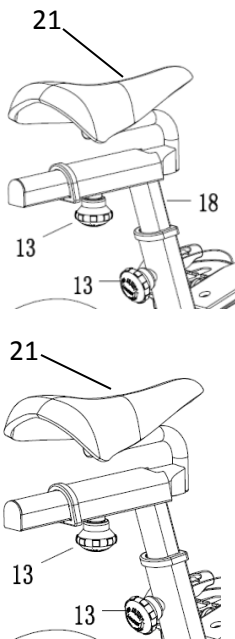

ADJUSTING THE SEAT

An appropriate seat height helps to ensure your exercise efficiency and reduce the risk of injury. Adjusting the seat forward or backward can help you work out different body muscle groups.

With one pedal in the upward position, place your foot in the toe clip and get on the bike. If your leg is bent too much, you should move the seat up. If your foot cannot touch the pedal or your leg is too straight, you should move the seat down. Dismount the bike before adjusting the seat.

Loosen the [seat adjustment] **Spring Knob (No. 13)** to raise or lower **Seat Post (No. 18)** to the desired position. Make sure **Spring Knob (No. 13)** secures into the desired hole.

Loosen **Spring Knob (No. 13)** to move the **Seat (No. 21)** forward or backward to the desired position. Once the position is located, firmly secure **Spring Knob (No. 13)** by turning *clockwise*.

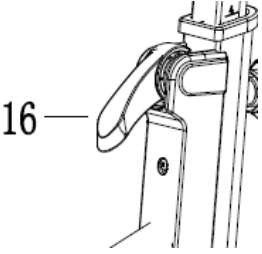
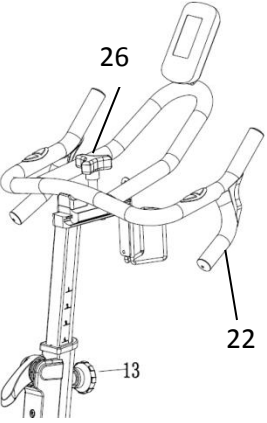
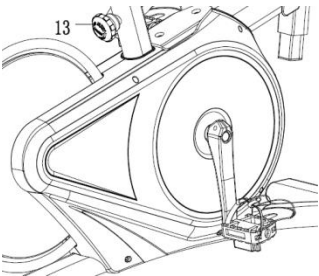
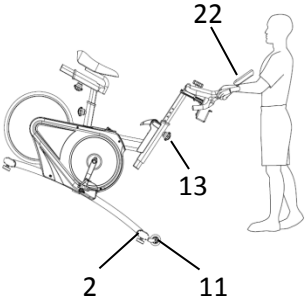
	<p>DISMOUNTING THE BIKE</p> <p>WARNING! Do not dismount the bike or remove your feet from the pedals until the pedals have stopped completely. You can stop the flywheel at any time by pushing down on Brake Handle (No. 16).</p>
	<p>ADJUSTING THE HANDLEBAR</p> <p>Loosen the [handlebar adjustment] Spring Knob (No. 13) to raise or lower the Handlebar (No. 22) to the desired position. Make sure the Spring Knob (No. 13) settles into the desired hole and secure it firmly by turning <i>clockwise</i>.</p> <p>Loosen Triangle Knob (No. 26) to move the Handlebar (No. 22) forward or backward to desired position. Tighten the Triangle Knob (No. 26) to secure.</p>
	<p>ADJUSTING THE PEDAL STRAP</p> <p>Place the ball of each foot in the toe clips so the front of your shoe fits snugly in the toe clip cage. Rotate one foot to within arm's reach and pull the strap until the top clip cage fits your shoe snugly. Insert the strap back into the hoop of the toe clip. Repeat this for the other foot.</p>
	<p>MOVING THE BIKE</p> <p>To move the bike, first ensure that the Handlebar (No. 22) is properly secured. If the Handlebar (No. 22) is loose, tighten the Spring Knob (No. 13) to secure it. Next, stand at the front of the bike so that you're directly in front of the Handlebar (No. 22). Firmly grasp and hold each side of the Handlebar (No. 22), place one foot on the front stabilizer and tilt the bike towards you until the Transportation Wheels (No. 11) on the Front Stabilizer (No. 2) touch the ground. With the Transportation Wheels (No. 11) on the ground, you can transport the bike to the desired location with ease.</p>

MAINTENANCE INSTRUCTIONS

This is general information for daily, weekly and monthly maintenance to be performed on your bike.

<p>DAILY MAINTENANCE</p> <p>After each exercise session, wipe down all the equipment: seat, frame, and handlebars. Pay special attention to the seat post, handlebar post and belt/chain guard. Sweat is very corrosive and may cause problems that require parts replacement later.</p> <ol style="list-style-type: none"> 1. Get on the bike and engage the drive train. 2. Pay attention to any vibrations felt through the pedals. If you feel any vibrations, you may need to tighten the pedals, bottom bracket, or adjust the drive belt/chain tension. 3. Use a wrench to tighten the pedals until they are secure. 	<p>MONTHLY MAINTENANCE</p> <ol style="list-style-type: none"> 1. Check all hardware is secure, such as: water bottle holder, flywheel nuts, belt/chain guard bolts, brake caliper lock nuts and brake caliper tension rod nuts. 2. Inspect the brake tension rod for signs of wear such as missing threads. Clean and lubricate the brake tension rod. 3. Clean and lubricate the seat post, handlebar post and seat slider. Remove any buildup of foreign material.
<p>WEEKLY MAINTENANCE</p> <ol style="list-style-type: none"> 1. Inspect moving parts and tighten the hardware. 2. Inspect pull pin frame fittings, making sure the fittings are snug. Loose frame fittings may strip out threads over time and cause extensive damage. 3. Clean and lubricate pop pin assemblies. Pull on the pin and spray a small amount of lubricant onto the shaft. 4. Tighten the seat hardware, to make sure the seat is level and centered. 5. Brush and treat the resistance pads. Remove any foreign material that may have collected on the pads. Spray the pads with silicone lubricant. This helps to reduce noise from friction between the pads and the flywheel. 6. Visually inspect the bottom bracket, toe clips and toe straps. If any of them are loose or disconnected, attach and tighten. 	<p>LEATHER BRAKE PAD CARE (If Applicable)</p> <ol style="list-style-type: none"> 1. Perform this maintenance when the brake pad is first installed and for the life of the brake pad. Following these simple guidelines can increase the life of your brake pads. 2. Some brake pad assemblies are pre-lubricated. Squeeze the brake pad. If lubricant is released, then the pad has been pre-lubricated. 3. If the brake pad is dry, then coat the brake pad with 3-n-1 oil. Brush the leather with a clean, wire bristle brush, and then apply the oil. The oil should be allowed to soak in to the pad. Repeat 4-5 times until the pad is saturated, but not dripping with oil. When the pad is saturated, it will no longer absorb oil. 4. Inspect the brake pad weekly and lubricate if needed. The pad should not have a glazed appearance. If the pad appears glazed, then brush it with wire brush and apply lubricant as needed. If any of the sponge padding is showing through the leather pad, the brake pad should be replaced.

BATTERY INSTALLATION & REPLACEMENT

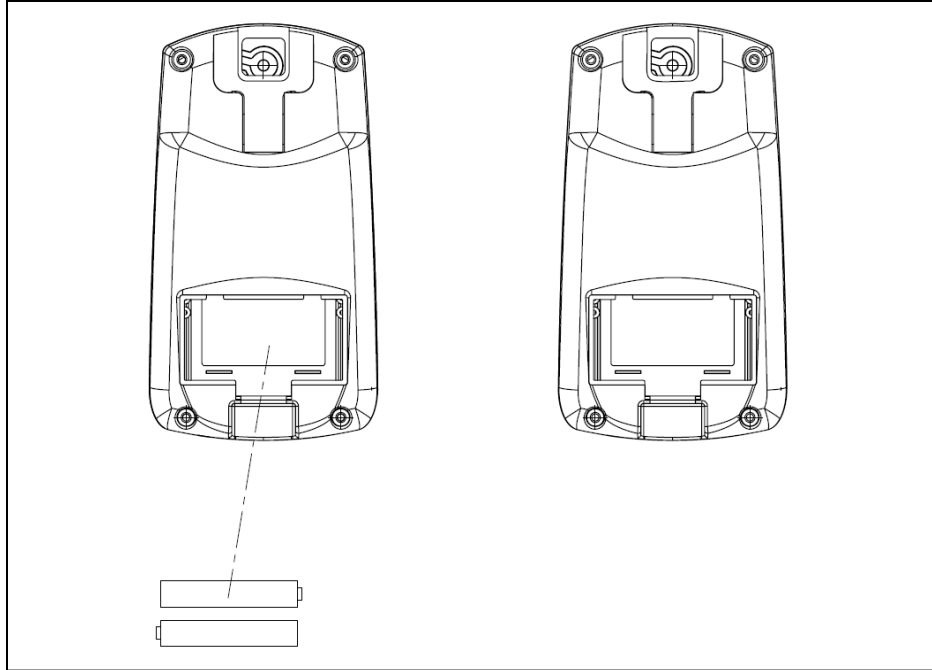

BATTERY INSTALLATION

The meter uses 2 AAA batteries. Open the battery cover from the back of meter, then put 2 batteries into the battery compartment. Make sure the (+) and (-) ends of the batteries are in the correct position. Put the battery cover back.

BATTERY REPLACEMENT

If there is a problem with the display, try changing the batteries first. Open the battery cover, remove the old batteries, and replace with new batteries. Make sure the (+) and (-) ends of the batteries are in the correct position. Put the battery cover back. When changing batteries, always replace both with new batteries. Do not mix old and new batteries.

EXERCISE METER

FUNCTION BUTTONS

MODE:

Press to select the function displayed or enter value during setting mode.

Press and hold for 2 seconds to enter the RACE MODE interface during stop mode.

SET:

To set up the target value of TARGET, TIME, DIST, CAL.

Press the button and hold for 2 seconds to speed up the increment during stop mode.

RESET:

Press the button to reset function value during setting mode.

Press the button and hold for 2 seconds to reset all value to zero.

(When the user replaces the batteries, all values will reset to zero.)

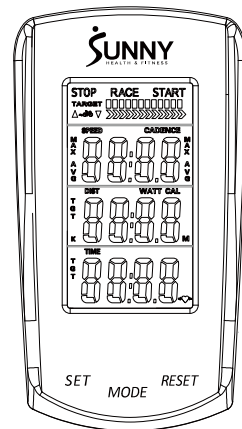

FUNCTIONS:

SPEED: Displays the speed from 0 to 99.9 KPH or MPH.

AVG SPEED: Displays the average speed only in STOP mode.

MAX SPEED: Displays the maximum speed only in STOP mode.

CADENCE (RPM): Displays the frequency per minute from 0 to 999.

AVG CADENCE (AVG RPM): Displays the average cadence (RPM) in STOP mode.

MAX CADENCE (MAX RPM): Displays the maximum cadence (RPM) in STOP mode.

DISTANCE (DIST): Accumulates total distance from 0.0 to 999.9 KM or Miles. User can preset TARGET DISTANCE by pressing MODE & SET.

TARGET DISTANCE (TGT DIST): Users can preset the Distance in the TARGET mode.

CALORIES (CAL): Accumulate total Calories from 0.0 to 9999. User can preset target calories.

RACE: Exercise in the TARGET MODE.

TIME: Accumulates total time from 00:00 to 99:59. User can preset target Time.

TARGET TIME: Users can preset the Time in the TARGET MODE.

PULSE: Display the current pulse rate.

MILES OR KILOMETERS SETTING:

The default setting is miles. Press and hold SET and MODE together for 2 seconds to change to kilometers.

SET TARGET VALUES:

1. Press SET to select a target value. CADENCE will start to flash.
2. Press and hold SET and the value will increase continuously.
3. Press MODE to enter.
4. TIME will flash.
5. Press SET to select a value.
6. Press MODE to enter.
7. Repeat to select values for DIST and CAL.

TARGET

1. TARGET: the preset CADENCE.
2. In STOP mode, press SET button to enter the TARGET setting in stop mode. Press SET to increase the CADENCE five at a time. The setting change is 15 →20→110→115→120→15→20→.....→115→120→ 15 →20→
3. The setting range of 15 -120 (Preset value is 60 CADENCES which equals six bars).
4. Each bar equals 10 CADENCE. Total is 12 bars.



← TARGET CADENCE
← CURRENT CADENCE

When Current CADENCE is less than Target CADENCE, the up arrow next to the bicycle will be displayed.



Each arrow equals 10 CADENCES (1-10 CADENCES displays one arrow, 11-20 displays two). The maximum arrows displayed is 12.



This down arrow next to the bicycle icon will be displayed when the current CADENCE is more than the TARGET CADENCE. The bicycle icon will be displayed during exercise mode.

RACE MODE:

Press and hold MODE for 2 seconds to enter RACE mode.

In RACE MODE, only TIME and DIST can be set.

Default values for 10 minutes / 4 (KM or Miles).

Total is 10 bars.



PULSE:

To measure the pulse, press MODE until meter is on the PULSE function. Hold the hand pulse sensors for at least 5 seconds to measure your pulse. This value is for reference only. It cannot be used as the basis for medical treatment.

BATTERY: This meter uses two AAA batteries. If the display appears incorrectly or becomes difficult to read, please install new batteries. Always change both batteries at the same time. Do not mix battery types and do not mix old and new batteries. Dispose of batteries according to your state and regional guidelines.

CONNECT WITH US

FOR FITNESS
ARTICLES, VIDEOS
& WORKOUTS



@SUNNYHEALTHANDFITNESS



@SUNNYHEALTHFITNESS



@SUNNYHEALTHFIT



/SUNNYHEALTHFITNESS



/SUNNYHEALTHANDFITNESS

WWW.SUNNYHEALTHFITNESS.COM