

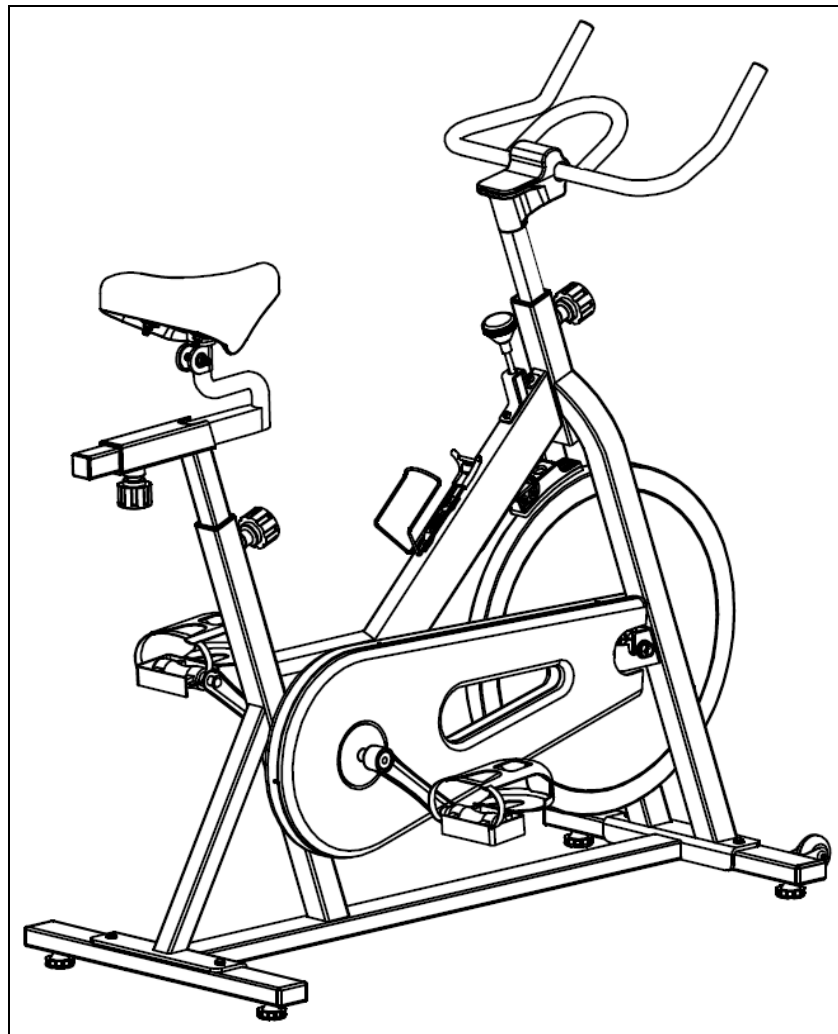

# INDOOR CYCLING BIKE

## SF-B1001S

### USER MANUAL



**IMPORTANT!** Please retain owner's manual for maintenance and adjustment instructions. Your satisfaction is very important to us, **PLEASE DO NOT RETURN UNTIL YOU HAVE CONTACTED US:** [support@sunnyhealthfitness.com](mailto:support@sunnyhealthfitness.com) or 1-877-90SUNNY (877-907-8669).



# **IMPORTANT SAFETY INFORMATION**

We thank you for choosing our product. To ensure your safety and health, please use this equipment correctly. It is important to read this entire manual before assembling and using the equipment. Safe and effective use can only be achieved if the equipment is assembled, maintained and used properly. It is your responsibility to ensure that all users of the equipment are informed of all warnings and precautions.

1. Before starting any exercise program, you should consult your physician to determine if you have any medical or physical conditions that could put your health and safety at risk or prevent you from using the equipment properly. Your physician's advice is essential if you are taking medication that affects your heart rate, blood pressure or cholesterol level.
2. Be aware of your body's signals. Incorrect or excessive exercise can damage your health. Stop exercising if you experience any of the following symptoms: pain, tightness in your chest, irregular heartbeat, shortness of breath, lightheadedness, dizziness or feelings of nausea. If you do experience any of these conditions, you should consult your physician before continuing with your exercise program.
3. Keep children and pets away from the equipment. The equipment is designed for adult use only.
4. Use the equipment on a solid, flat level surface with a protective cover for your floor or carpet. To ensure safety, the equipment should have at least 4 feet (1.2 M) of free space all around it.
5. Ensure that all nuts and bolts are securely tightened before using the equipment. The safety of the equipment can only be maintained if it is regularly examined for damage and/or wear and tear.
6. Always use the equipment as indicated. If you find any defective components while assembling or checking the equipment, or if you hear any unusual noises coming from the equipment during exercise, discontinue use of the equipment immediately and do not use until the problem has been rectified.
7. Wear suitable clothing while using the equipment. Avoid wearing loose clothing that may become entangled in the equipment.
8. Do not place fingers or objects into the moving parts of the equipment.
9. The maximum weight capacity of this unit is 220 pounds (100 KG).
10. The equipment is not suitable for therapeutic use.
11. To avoid bodily injury and/or damage to the product or property, proper lifting and moving is required.
12. Your product is intended for use in cool, dry conditions. You should avoid storage in extreme cold, hot or damp areas as this may lead to corrosion and other related problems.
13. This equipment is designed for indoor and home use only, it is not intended for commercial use!

# EXPLODED DIAGRAM

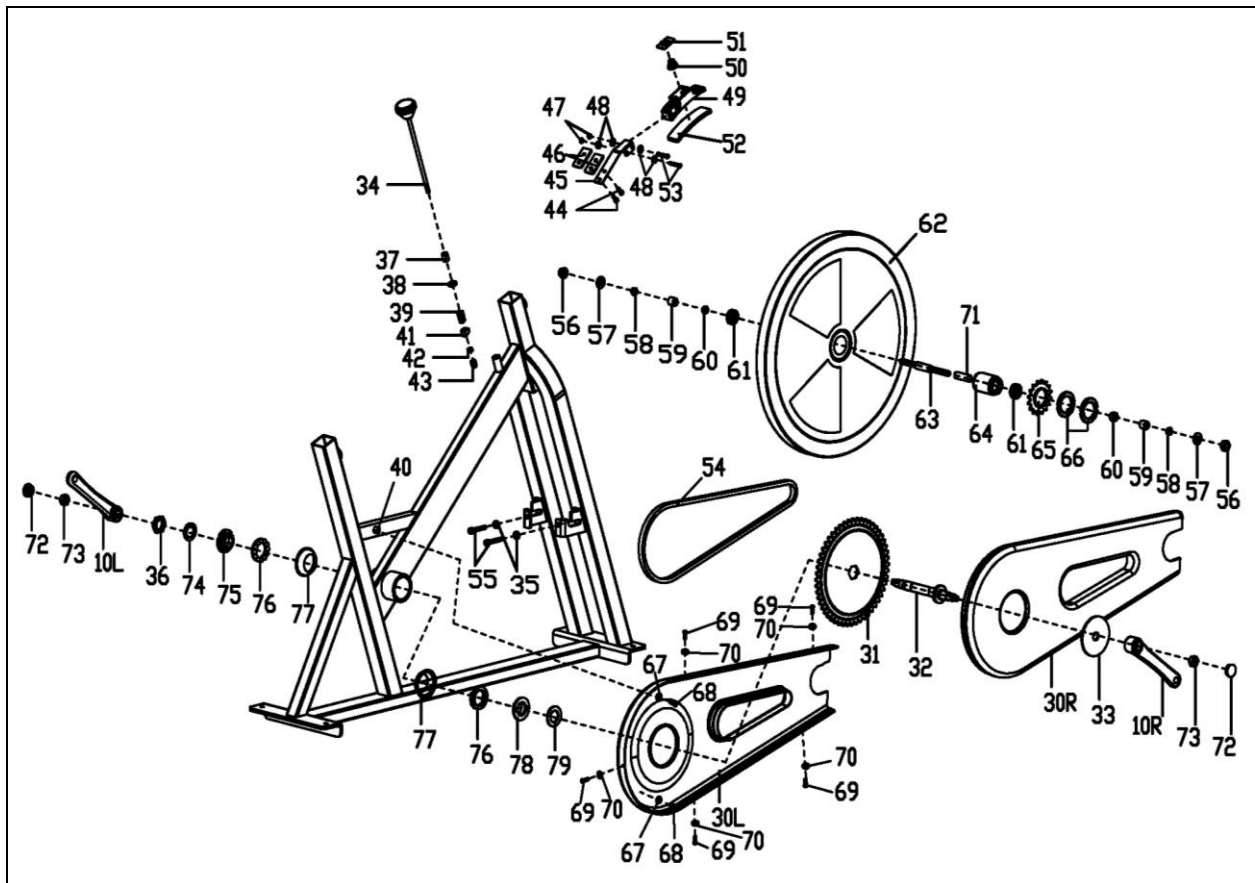
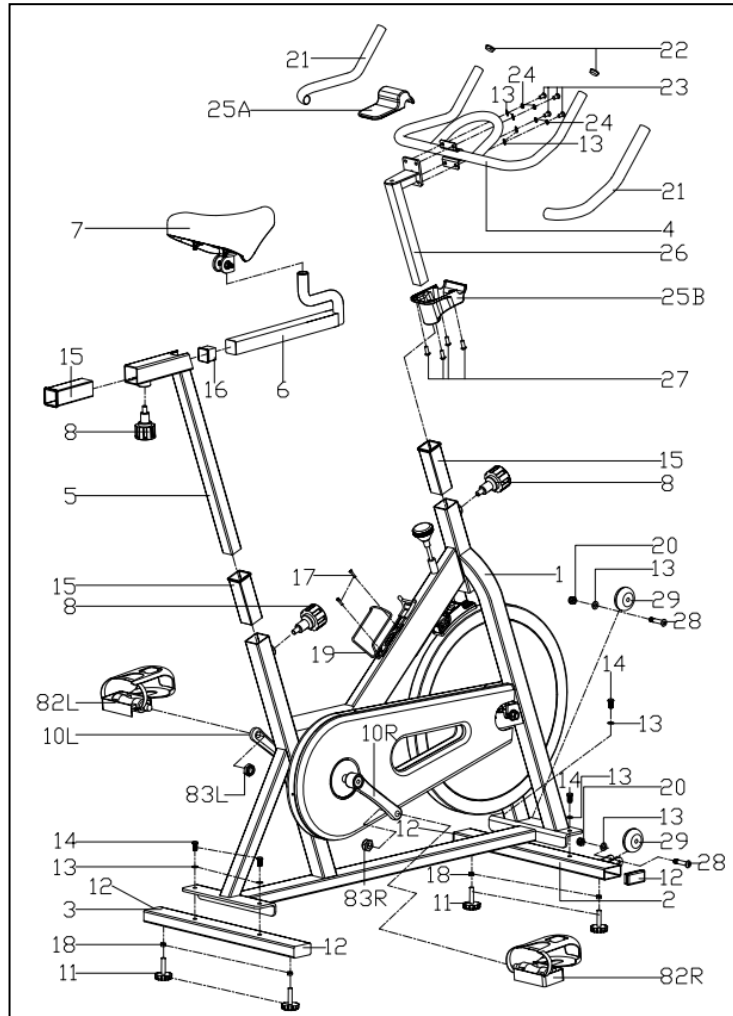

# PARTS LIST

No.	Description	Spec.	Qty.
1	Main Frame		1
2	Front Stabilizer		1
3	Rear Stabilizer		1
4	Handlebar		1
5	Seat Post		1
6	Seat Slider		1
7	Seat		1
8	Pop-Pin Knob		3
9L/R	Refer to #82L/R		-
10L/R	Crank		1 pr.
11	Foot Leveler		4
12	Square Cap		4
13	Flat Washer	Φ8X1.5XΦ16	10
14	Allen Bolt	M8X20XΦ15	4
15	Plastic Bushing		3
16	Square Cap		1
17	Phillips Tapping Screw	M5XL12	2
18	Hex Nut	M10	4
19	Water Bottle Holder		1
20	Nylon Nut	M8	2
21	Foam Grip		2
22	Cap		2
23	Allen Bolt	M8X16XΦ15	4
24	Spring Washer	D8	4
25 A/B	Handlebar Cover		1 pr.
26	Handlebar Post		1
27	Phillips Screw	ST4X8	4
28	Allen Bolt	M8X40XL12	2
29	Roller		2
30L/R	Chain Cover		1pr.
31	Chain Plate		1
32	Center Axle		1

No.	Description	Spec.	Qty.
33	Protective Cover		1
34	Brake Knob		1
35	Hex Nut	M8	2
36	Hex Nut		1
37	Spacer	Φ12XΦ9X15	1
38	Square Nut	M8	1
39	Spring		1
40	Mat Cover		1
41	Block		1
42	Hex Nut	M6	1
43	Nylon Nut	M6	1
44	Phillips Tapping Screw	M5X15	2
45	Spring Clamp		1
46	Rubber Pad		2
47	Nylon Nut	M5	2
48	Flat Washer	D5	4
49	Fixed Bracket		1
50	Conical Spring		1
51	Brake Block		1
52	Wool Felt		1
53	Phillips Screw	M5X30	2
54	Chain		1
55	Phillips Tapping Screw	M8X45	2
56	Cap Nut	M12	2
57	Flat Washer	Φ25XΦ13X2	2
58	Hex Thin Nut	M12X1	2
59	Spacer	Φ18XΦ12.2X 9	2
60	Conical Thin Nut	M12X1	2
61	Bearing		2
62	Flywheel		1
63	Flywheel Axle		1
64	Wheel Inner Sleeve		1

65	Small Chain Wheel		1
66	Nut		2
67	Flat Washer	Φ5.5X1.0XΦ12	2
68	Cross Pan Head Tapping Screw	ST4.2X25	2
69	Cross Pan Head Tapping Screw	ST5X10	5
70	Flat Washer	Φ5.5X0.5XΦ10	5
71	Long Spacer	Φ16XΦ12X41	1
72	Crank Cover		2
73	Flange Nut	M10X1.25	2
74	Stop Washer		1

75	Two-Slot Nut		1
76	Ball Bearing		2
77	Centre Bowl		2
78	Three Slot Nut		1
79	Big Flat Washer		1
80	Allen Wrench	S6	1
81	Spanner	S10,13, 14, 15,17	1
82L/R	Pedal		1 pr.
83L/R	Nylon Nut	9/16"*20	1 pr.
84	Spanner	S8,14,22	1



### Ordering Replacement Parts (U.S. and Canadian Customers only)

Please provide the following information in order for us to accurately identify the part(s) needed:

- ✓ The model number (found on cover of manual)
- ✓ The product name (found on cover of manual)
- ✓ The part number found on the "EXPLODED DIAGRAM" and "PARTS LIST" (found near the front of the manual)

Please contact us at [support@sunnyhealthfitness.com](mailto:support@sunnyhealthfitness.com) or 1- 877 - 90SUNNY (877-907-8669).

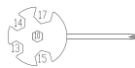
## HARDWARE PACKAGE

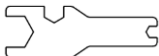
 <p>———— # 80 Allen Wrench S6 1PC</p>	 <p>———— # 81 Spanner S10, 13, 14, 15, 17 1PC</p>
 <p>———— # 8 Pop-Pin Knob 2PCS</p>	 <p>———— # 84 Spanner S8, 14, 22 1PC</p>

# ASSEMBLY INSTRUCTIONS

We value your experience using Sunny Health and Fitness products. For assistance with parts or troubleshooting, please contact us at [support@sunnyhealthfitness.com](mailto:support@sunnyhealthfitness.com) or 1-877-90SUNNY (877-907-8669).

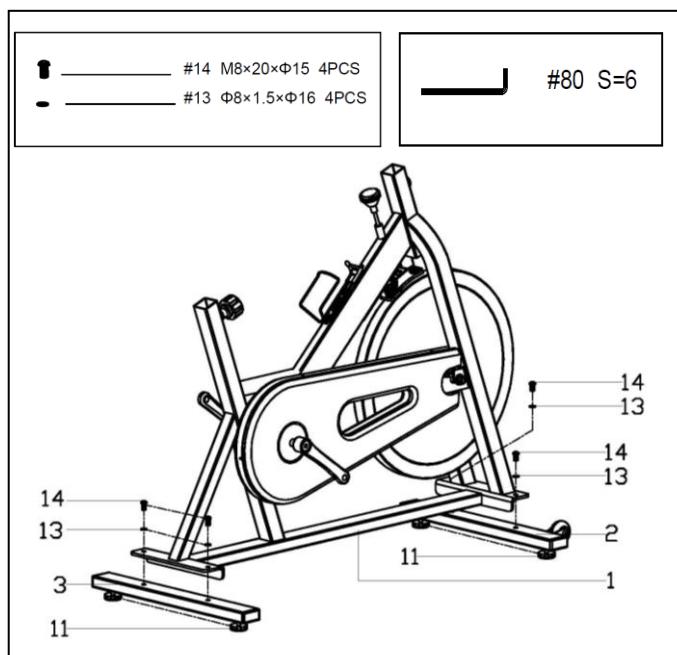

## STEP 1:

Remove the preassembled 4 **Allen Bolts (No. 14)** and 4 **Flat Washers (No. 13)** from the **Front Stabilizer (No. 2)** and **Rear Stabilizer (No. 3)**.

Attach the **Front Stabilizer (No. 2)** and **Rear Stabilizer (No. 3)** to the **Main Frame (No. 1)** with 4 **Allen Bolts (No. 14)** and 4 **Flat Washers (No. 13)**. Tighten and secure with **Allen Wrench (No. 80)**. Make sure the **Foot Levelers (No. 11)** are on the bottom and the transportation wheels facing up at the front of the bike.

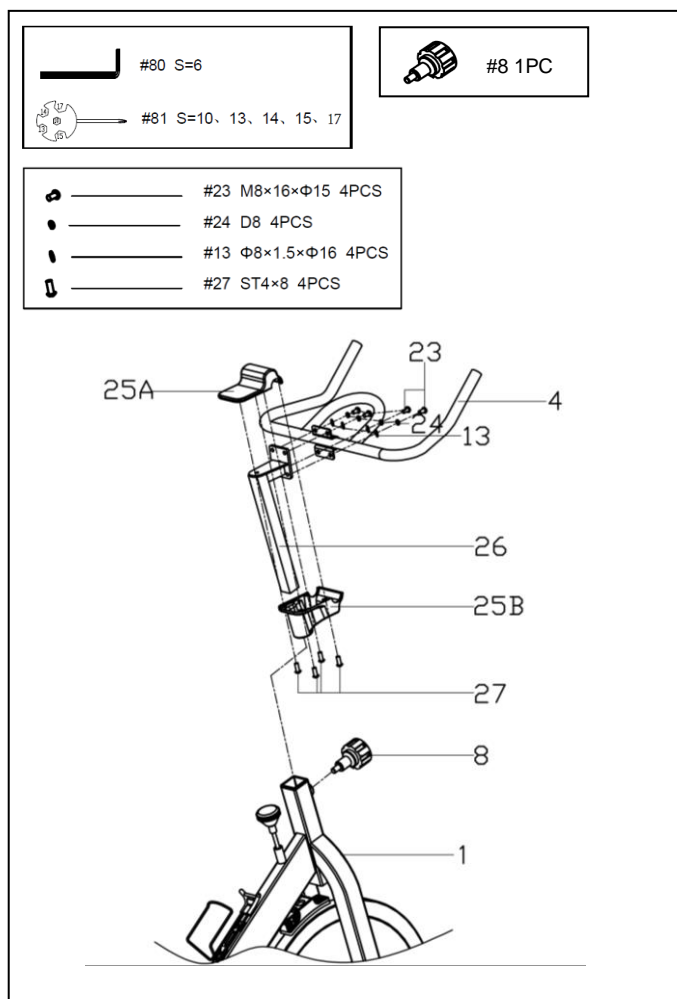

## STEP 2:

Remove the preassembled 4 **Allen Bolts (No. 23)**, 4 **Flat Washers (No. 13)** and 4 **Spring Washers (No. 24)** from **Handlebar Post (No. 26)**. Attach the **Handlebar (No. 4)** to the **Handlebar Post (No. 26)** using 4 **Allen Bolts (No. 23)**, 4 **Flat Washers (No. 13)** and 4 **Spring Washers (No. 24)**. Tighten and secure with **Allen Wrench (No. 80)**.

Remove the preassembled 4 **Phillips Screws (No. 27)** from **Top Handlebar Cover (No. 25A)**. Insert **Handlebar Post (No. 26)** through **Lower Handlebar Cover (No. 25B)**. Slide the **Lower Handlebar Cover (No. 25B)** to the top of the **Handlebar Post (No. 26)**.

Use 4 **Phillips Screws (No. 27)** to attach the **Top Handlebar Cover (No. 25A)** to the **Lower Handlebar Cover (No. 25B)** so the **Handlebar (No. 4)** and **Handlebar Post (No. 26)** are in between the **Handlebar Covers (No. 25A & No. 25B)**.

Insert the handlebar assembly into the **Main Frame (No. 1)** and secure with **Pop-Pin Knob (No. 8)**. Make sure the pin settles into the desired hole.

We value your experience using Sunny Health and Fitness products. For assistance with parts or troubleshooting, please contact us at [support@sunnyhealthfitness.com](mailto:support@sunnyhealthfitness.com) or 1-877-90SUNNY (877-907-8669).

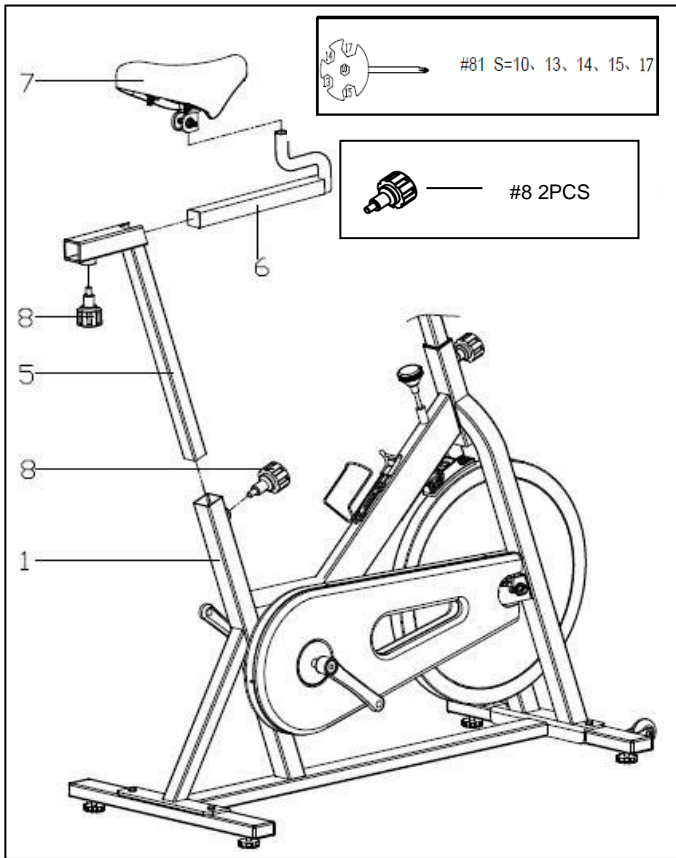

### STEP 3:

Lock the **Seat (No. 7)** onto the **Seat Slider (No. 6)** tightly. Tighten and secure with **Spanner (No. 81)**. Adjust the **Seat (No. 7)** to the desired position by sliding it on **Seat Slider (No. 6)** then lock the **Seat Slider (No. 6)** on the **Seat Post (No. 5)** with **Pop-Pin Knob (No. 8)**.

Loosen the pre-assembled **Pop-Pin Knob (No. 8)** on the rear upright tube of **Main frame (No. 1)**, then insert the **Seat Post (No. 5)** to the rear upright tube of **Main Frame (No. 1)**. Adjust the height and secure with the **Pop-Pin Knob (No. 8)**.

**Note:** Both the fore/aft and up/down adjustments of the **Seat (No. 7)** need to be secured with **Pop-Pin Knob (No. 8)**. Ensure the **Seat (No. 7)** is locked onto the **Seat Slider (No. 6)** before adjusting the height.

We value your experience using Sunny Health and Fitness products. For assistance with parts or troubleshooting, please contact us at [support@sunnyhealthfitness.com](mailto:support@sunnyhealthfitness.com) or 1-877-90SUNNY (877-907-8669).

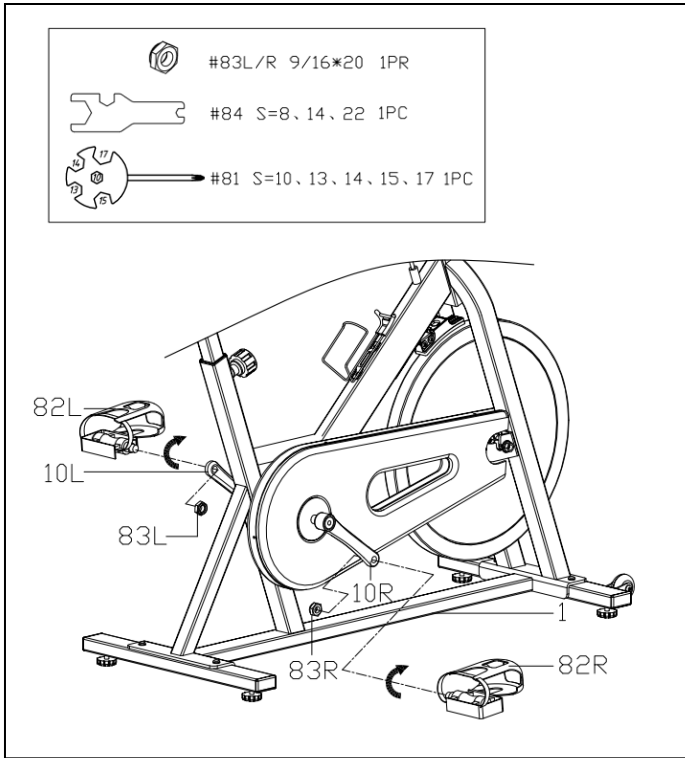

#### STEP 4:

**IMPORTANT! Read instructions carefully, failure to do so may cause permanent damage to your bike.**

Remove the **Left & Right Nylon Nuts (No. 83L/R)** located on the **Pedals (No. 82L/R)**. The **Right Nylon Nut (No. 83R)** is white on the inside. The **Left Nylon Nut (No. 83L)** is blue on the inside.

Screw the **Left Pedal (No. 82L)** **COUNTER-CLOCKWISE** into the **Left Crank (No. 10L)** by using the **Spanner (No. 81)**. Once it is properly screwed into the place, use the **Spanner (No. 81)** to hold the bolt of the pedal and screw the **Left Nylon Nut (No. 83L)** **CLOCKWISE** to the thread end of the **Left Pedal (No. 82L)** securely with **Spanner (No. 84)**.

Screw the **Right Pedal (No. 82R)** **CLOCKWISE** into the **Right Crank (No. 10R)** by using the **Spanner (No. 81)**. Once properly screwed into the place, use the **Spanner (No. 81)** to hold the bolt of the pedal and screw the **Right Nylon Nut (No. 83R)** **COUNTER-CLOCKWISE** to the thread end of the **Right Pedal (No. 82R)** securely with **Spanner (No. 84)**.

Assembly is complete!



# ADJUSTMENTS & USAGE GUIDE

<p>#81 S=10, 13, 14, 15, 17</p>	<h3>ADJUSTING THE BALANCE</h3> <p>In order to achieve a smooth and comfortable ride, you must ensure that the stability of the bike is secured. If you notice that the bike is unbalanced during use, you should adjust the foot levelers located beneath the front and rear stabilizers. To do so, use <b>Spanner (No. 81)</b> to loosen <b>Hex Nut (No. 18)</b> by turning it <i>clockwise</i> (direction A). With the nut loosened, rotate <b>Foot Levelers (No. 11)</b> until it sits level with the surface that the bike is on. When you have finished adjusting the foot leveler, use <b>Spanner (No. 81)</b> to re-tighten the <b>Hex Nut (No. 18)</b> by turning it <i>counter-clockwise</i> (direction B). If required, repeat this process to adjust the remaining <b>Foot Levelers (No. 11)</b>.</p>
	<h3>ADJUSTING THE TENSION &amp; EMERGENCY STOP</h3> <p>Adjust the resistance of the bike using the <b>Brake Knob (No. 34)</b>. Increase the level of resistance by turning the brake knob to the RIGHT (clockwise), decrease the level of resistance by turning the brake knob to the LEFT (counter-clockwise). Push down on the <b>Brake Knob (No. 34)</b> for emergency brake.</p>
	<h3>ADJUSTING THE SEAT</h3> <p>An appropriate seat height helps to ensure your exercise efficiency and reduce the risk of injury. Adjusting the seat forward or backward can help you work out different body muscle groups.</p> <p>With one pedal in the upward position, place your foot in the toe clip and get on the bike. If your leg is bent too much, you should move the seat up. If your foot cannot touch the pedal or your leg is too straight, you should move the seat down. Dismount the bike.</p> <p>Loosen the [seat adjustment] <b>Pop-Pin Knob (No. 8)</b> to raise or lower <b>Seat Post (No. 5)</b> to the desired position. Make sure <b>Pop-Pin Knob (No. 8)</b> secures into the desired hole.</p> <p>Loosen <b>Pop-Pin Knob (No. 8)</b> to move the seat forward or backward to the desired position. Once the position is located, firmly secure <b>Pop-Pin Knob (No. 8)</b> by turning <i>clockwise</i>.</p>

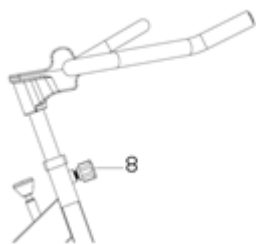

### ADJUSTING THE HANDLEBAR

Loosen the [handlebar adjustment] **Pop-Pin Knob (No. 8)** to raise or lower the handlebar to the desired position. Make sure the **Pop-Pin Knob (No. 8)** settles into the desired hole and secure it firmly by turning *clockwise*.

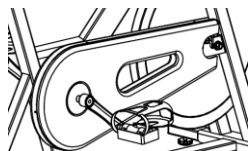

### ADJUSTING THE PEDAL STRAP

Place the ball of each foot in the toe clips so the front of your shoe fits snugly in the toe clip cage. Rotate one foot to within arm's reach and pull the strap until the top clip cage fits your shoe snugly. Insert the strap back into the hoop of the toe clip. Repeat this for the other foot.

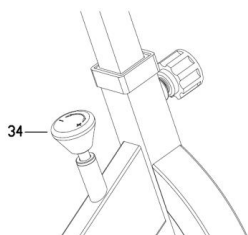

### DISMOUNTING THE BIKE

Stop the flywheel at any time by pushing down on **Brake Knob (No. 34)**. When the pedals have stopped moving, loosen the pedal straps. Then you can dismount the bike.

**WARNING!** Do not dismount the bike or remove your feet from the pedals until the pedals have stopped completely.

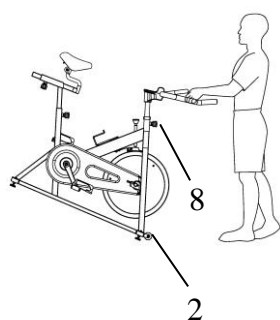

### MOVING THE BIKE

To move the bike, first ensure that the handlebar is properly secured. If the handlebar is loose, tighten the **Pop-Pin Knob (No. 8)** to secure it. Next, stand at the front of the bike so that you're directly in front of the handlebar. Firmly grasp and hold each side of the handlebar, place one foot on the **Front Stabilizer (No. 2)** and tilt the bike towards you until the transportation wheels on the **Front Stabilizer (No. 2)** touch the ground. With the wheels on the ground, you can transport the bike to the desired location with ease.

# **MAINTENANCE INSTRUCTIONS**

This is general information for daily, weekly and monthly maintenance to be performed on your bike.

<p><b>DAILY MAINTENANCE</b></p> <p>After each exercise session, wipe down all the equipment: seat, frame, and handlebars. Pay special attention to the seat post, handlebar post, and belt/chain guard. Sweat is very corrosive and may cause problems that require parts replacement later.</p> <ol style="list-style-type: none"> <li>1. Get on the bike and engage the drive train.</li> <li>2. Pay attention to any vibrations felt through the pedals. If you feel any vibrations, you may need to tighten the pedals, bottom bracket, or adjust the drive belt/chain tension.</li> <li>3. Use a wrench to tighten the pedals until they are secure.</li> </ol>	<p><b>MONTHLY MAINTENANCE</b></p> <ol style="list-style-type: none"> <li>1. Check all hardware is secure, such as: water bottle holder, flywheel nuts, belt/chain guard bolts, brake caliper lock nuts, and brake caliper tension rod nuts.</li> <li>2. Inspect the brake tension rod for signs of wear such as missing threads. Clean and lubricate the brake tension rod.</li> <li>3. Clean and lubricate the seat post, handlebar post and seat slider. Remove any buildup of foreign material.</li> </ol>
<p><b>WEEKLY MAINTENANCE</b></p> <ol style="list-style-type: none"> <li>1. Inspect moving parts and tighten the hardware.</li> <li>2. Inspect pull pin frame fittings, making sure the fittings are snug. Loose frame fittings may strip out threads over time and cause extensive damage.</li> <li>3. Clean and lubricate pop pin assemblies. Pull on the pin and spray a small amount of lubricant onto the shaft.</li> <li>4. Tighten the seat hardware, to make sure the seat is level and centered.</li> <li>5. Brush and treat the resistance pads. Remove any foreign material that may have collected on the pads. Spray the pads with silicone lubricant. This helps to reduce noise from friction between the pads and the flywheel.</li> <li>6. Visually inspect the bottom bracket, toe clips and toe straps. If any of them are loose or disconnected, attach and tighten.</li> </ol>	<p><b>LEATHER BRAKE PAD CARE (If Applicable)</b></p> <ol style="list-style-type: none"> <li>1. Perform this maintenance when the brake pad is first installed and for the life of the brake pad. Following these simple guidelines can increase the life of your brake pads.</li> <li>2. Some brake pad assemblies are pre-lubricated. Squeeze the brake pad. If lubricant is released, then the pad has been pre-lubricated.</li> <li>3. If the brake pad is dry, then coat the brake pad with 3-n-1 oil. Brush the leather with a clean, wire bristle brush, and then apply the oil. The oil should be allowed to soak in to the pad. Repeat 4-5 times until the pad is saturated, but not dripping with oil. When the pad is saturated, it will no longer absorb oil.</li> <li>4. Inspect the brake pad weekly and lubricate if needed. The pad should not have a glazed appearance. If the pad appears glazed, then brush it with wire brush and apply lubricant as needed. If any of the sponge padding is showing through the leather pad, the brake pad should be replaced.</li> </ol>

# CONNECT WITH US

FOR FITNESS  
ARTICLES, VIDEOS  
& WORKOUTS



@SUNNYHEALTHANDFITNESS



@SUNNYHEALTHFITNESS



@SUNNYHEALTHFIT



/SUNNYHEALTHFITNESS



/SUNNYHEALTHANDFITNESS

WWW.SUNNYHEALTHFITNESS.COM