

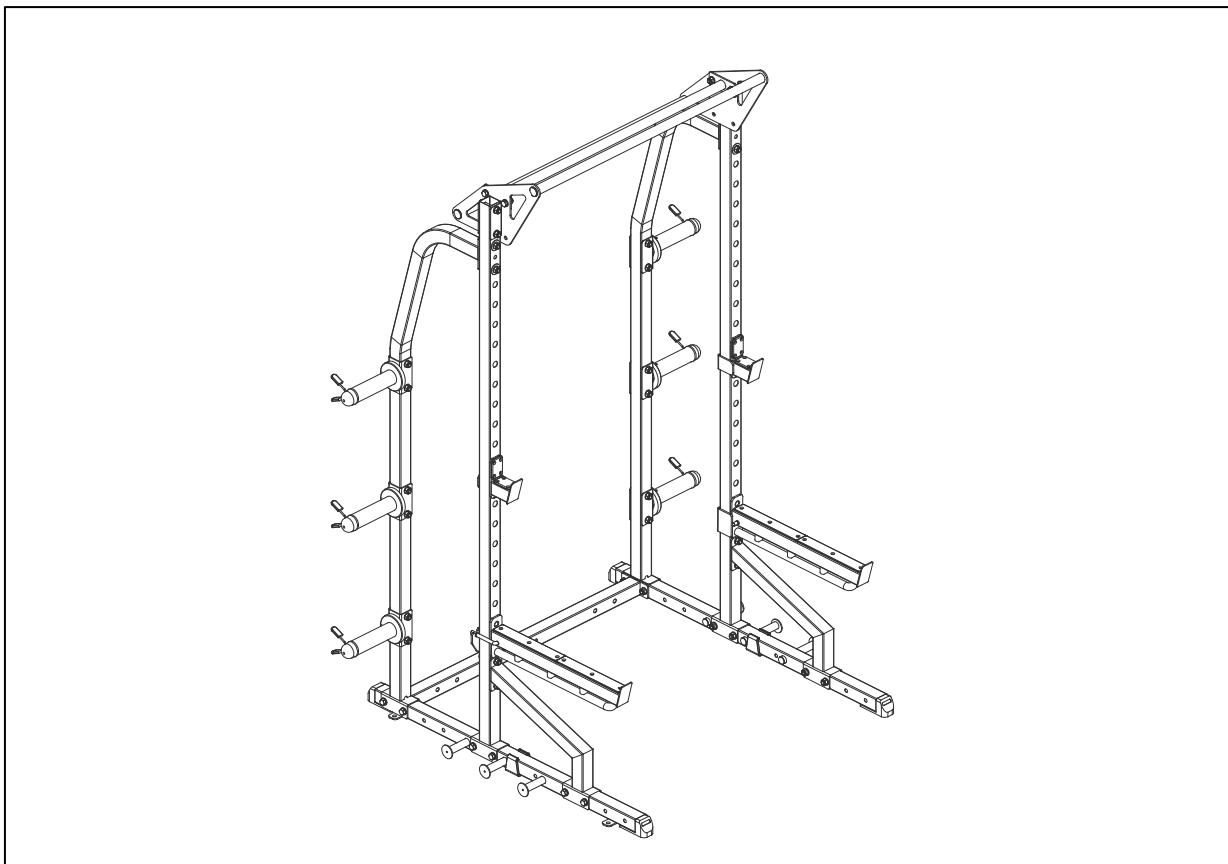

# POWER ZONE HALF RACK STRENGTH CAGE SF-XF9933 USER MANUAL



**IMPORTANT!** Please retain owner's manual for maintenance and adjustment instructions. Your satisfaction is very important to us, **PLEASE DO NOT RETURN UNTIL YOU HAVE CONTACTED US:** [support@sunnyhealthfitness.com](mailto:support@sunnyhealthfitness.com) or 1- 877 - 90SUNNY (877-907-8669).



WWW.SUNNYHEALTHFITNESS.COM

# **IMPORTANT SAFETY INFORMATION**

We thank you for choosing our product. To ensure your safety and health, please use this equipment correctly. It is important to read this entire manual before assembling and using the equipment. Safe and effective use can only be achieved if the equipment is assembled, maintained, and used properly. It is your responsibility to ensure that all users of the equipment are informed of all warnings and precautions.

1. Before starting any exercise program, you should consult your physician to determine if you have any medical or physical conditions that could put your health and safety at risk or prevent you from using the equipment properly. Your physician's advice is essential if you are taking medication that affects your heart rate, blood pressure, or cholesterol level.
2. Be aware of your body's signals. Incorrect or excessive exercise can damage your health. Stop exercising if you experience any of the following symptoms: pain, tightness in your chest, irregular heartbeat, shortness of breath, lightheadedness, dizziness, or feelings of nausea. If you do experience any of these conditions, you should consult your physician before continuing with your exercise program.
3. Keep children and pets away from the equipment. The equipment is designed for adult use only.
4. Use the equipment on a solid, flat level surface with a protective cover for your floor or carpet. To ensure safety, the equipment should have at least 4 feet (120 CM) of free space all around it.
5. Ensure that all nuts and bolts are securely tightened before using the equipment. The safety of the equipment can only be maintained if it is regularly examined for damage and/or wear and tear.
6. Always use the equipment as indicated. If you find any defective components while assembling or checking the equipment, or if you hear any unusual noises coming from the equipment during exercise, discontinue use of the equipment immediately and do not use until the problem has been rectified.
7. Wear suitable clothing while using the equipment. Avoid wearing loose clothing that may become entangled in the equipment.
8. Do not place fingers or objects into the moving parts of the equipment.
9. The maximum weight capacity of this unit is 1000 LBS (455KG).
10. The equipment is not suitable for therapeutic use.
11. To avoid bodily injury and/or damage to the product or property, proper lifting and moving are required.
12. Your product is intended for use in cool and dry conditions. You should avoid storage in extreme cold, hot or damp areas as this may lead to corrosion and other related problems.
13. This equipment is designed for indoor and home use only; it is not intended for commercial use.

# EXPLODED DIAGRAM

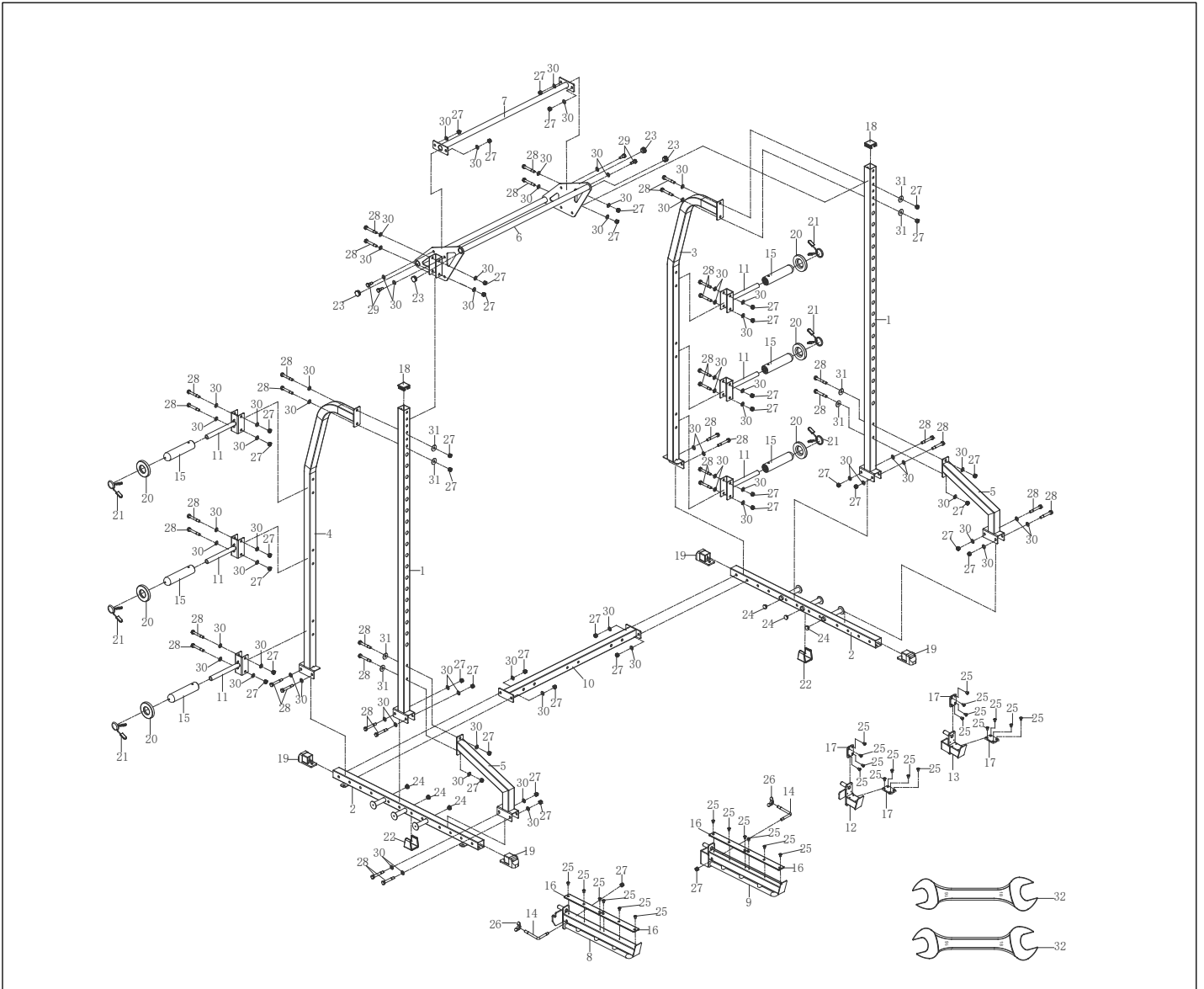

# HARDWARE PACKAGE

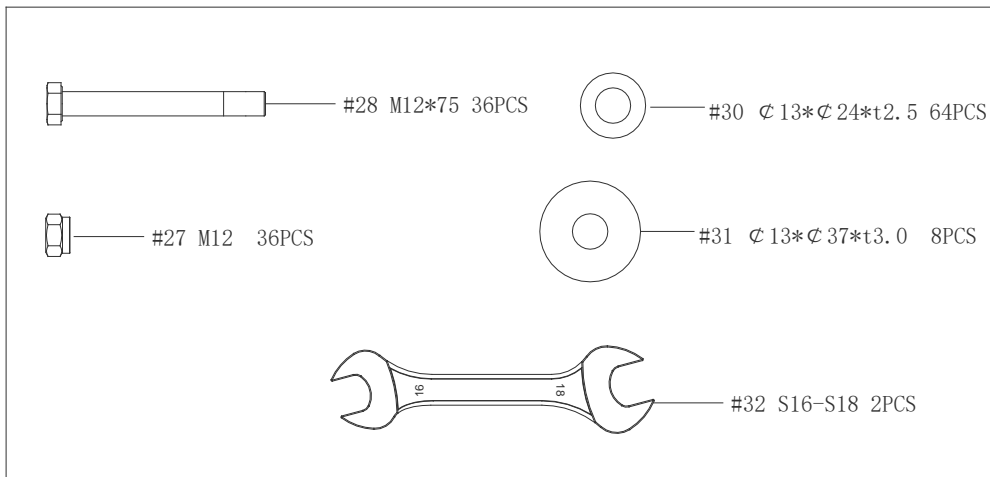

# PARTS LIST

No.	Description	Spec.	Qty.
1	Upright Post		2
2	Stabilizer		2
3	Left Support Frame		1
4	Right Support Frame		1
5	Hog Frame		2
6	Pull Up Bar		1
7	Horizontal Bar		1
8	Right Safety Bar		1
9	Left Safety Bar		1
10	Bottom Connecting Frame		1
11	Counterweight Rod		6
12	Right Hook		1
13	Left Hook		1
14	Limit Pin		2
15	Barbell Support Rod	∅ 100*∅ 48*200	6
16	Rubber Padding	290*45*t5.0	4

No.	Description	Spec.	Qty.
17	Rubber Padding	50*50*t2.0	4
18	Square End Cap	50*50*t5.0	2
19	End Cap	115*50	4
20	Crash Pad	∅ 80*∅ 50*16	6
21	Spring Clip	∅ 48	6
22	U Shape Foot Strap	50*50*t5.0	2
23	Round End Cap	∅ 32*t1.5	4
24	Round End Cap	∅ 25	6
25	Cross Recessed Countersunk Head Screw	M6*10	28
26	Butterfly Nut	M12	2
27	Hex Lock Nut	M12	42
28	Hexagon Bolt	M12*75	36
29	Hexagon Bolt	M12*30	4
30	Flat Washer	∅ 13*∅ 24*t2.5	72
31	Flat Big Washer	∅ 13*∅ 37*t3.0	8
32	Open End Wrench	S16-S18	2

## Ordering Replacement Parts (U.S. and Canadian Customers only)

Please provide the following information in order for us to accurately identify the part(s) needed:

- ✓ The model number (found on cover of manual)
- ✓ The product name (found on cover of manual)
- ✓ The part number found on the “EXPLODED DIAGRAM” and “PARTS LIST” (found near the front of the manual)

Please contact us at [support@sunnyhealthfitness.com](mailto:support@sunnyhealthfitness.com) or 1- 877- 90SUNNY (877-907-8669)

# ASSEMBLY INSTRUCTIONS

We value your experience using Sunny Health and Fitness products. For assistance with parts or troubleshooting, please contact us at [support@sunnyhealthfitness.com](mailto:support@sunnyhealthfitness.com) or 1-877-90SUNNY (877-907-8669).

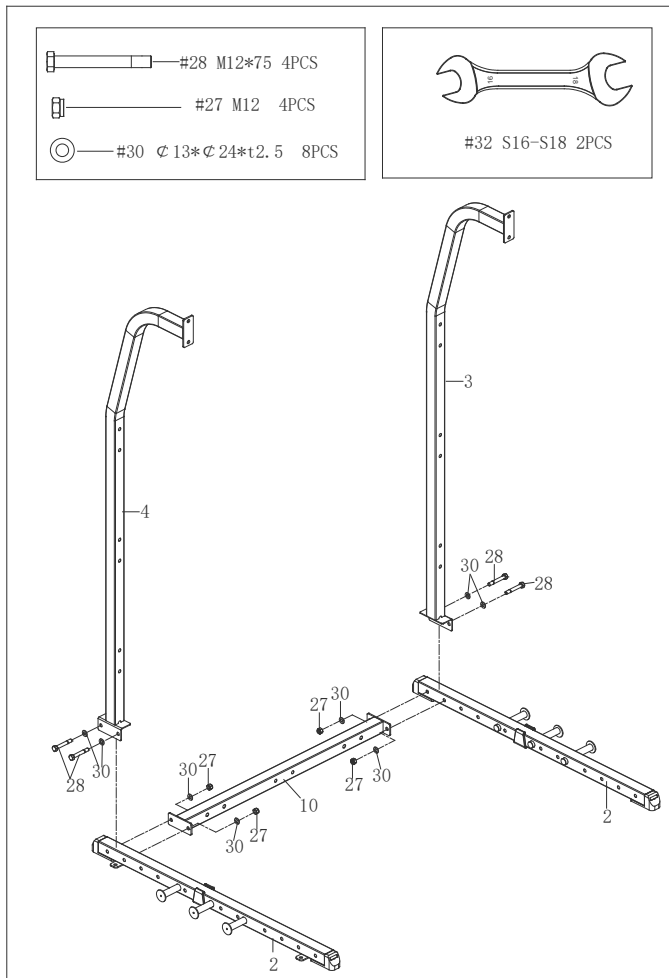

## STEP 1:

Attach **Right & Left Support Frames (No. 4 & No. 3)** and **2 Stabilizers (No. 2)** onto **Bottom Connecting Frame (No. 10)** using **4 Hexagon Bolts (No. 28)**, **4 Hex Lock Nuts (No. 27)**, and **8 Flat Washers (No. 30)**. Secure with **2 Open End Wrenches (No.32)**. Do not tighten the **4 Hex Lock Nuts (No. 27)** during this step.

We value your experience using Sunny Health and Fitness products. For assistance with parts or troubleshooting, please contact us at [support@sunnyhealthfitness.com](mailto:support@sunnyhealthfitness.com) or 1-877-90SUNNY (877-907-8669).

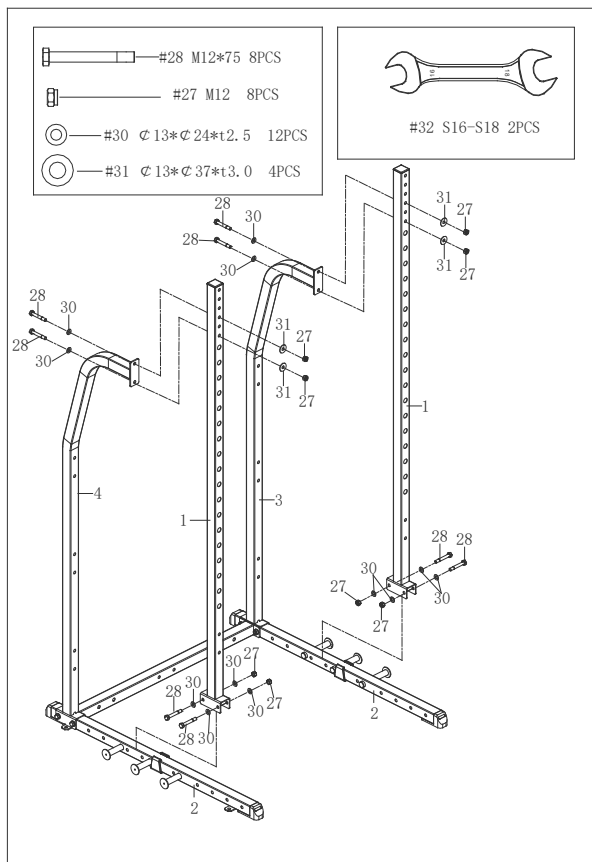

### STEP 2:

Attach 2 **Upright Posts (No. 1)** onto 2 **Stabilizers (No. 2)** using 4 **Hexagon Bolts (No. 28)**, 4 **Hex Lock Nuts (No. 27)** and 8 **Flat Washers (No. 30)**, Secure with 2 **Open End Wrenches (No.32)**. Do not tighten the 4 **Hex Lock Nuts (No. 27)** during this step.

The digits engraved on the 2 **Upright Posts (No. 1)** should be faced forward. (see figure A).

Attach 2 **Upright Posts** onto **Left Support Frame (No. 3)** and **Right Support Frame (No. 4)** using 4 **Hexagon Bolts (No. 28)**, 4 **Hex Lock Nuts (No. 27)**, 4 **Flat Washers (No. 30)** and 4 **Flat Big Washers (No. 31)**. Secure with 2 **Open End Wrenches (No.32)**. Do not tighten the 4 **Hex Lock Nuts (No. 27)** during this step.

We value your experience using Sunny Health and Fitness products. For assistance with parts or troubleshooting, please contact us at [support@sunnyhealthfitness.com](mailto:support@sunnyhealthfitness.com) or 1-877-90SUNNY (877-907-8669).

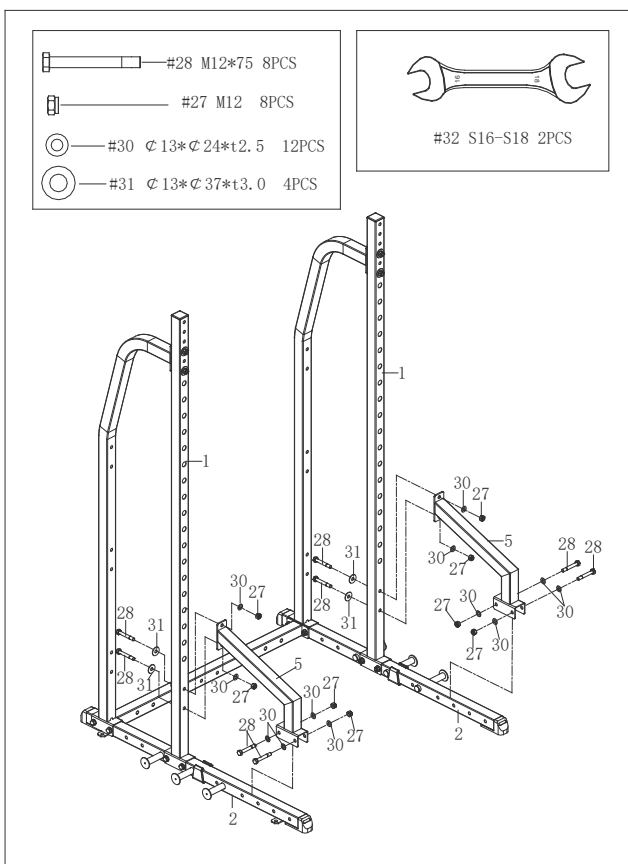

### STEP 3:

Attach 2 **Hog Frames (No. 5)** onto 2 **Stabilizers (No. 2)** using 4 **Hexagon Bolts (No. 28)**, 4 **Hex Lock Nuts (No. 27)** and 8 **Flat Washers (No. 30)**. Secure with 2 **Open End Wrenches (No. 32)**. Do not tighten the 4 **Hex Lock Nuts (No. 27)** during this step.

Attach 2 **Hog Frames (No. 5)** onto 2 **Upright Posts (No. 1)** using 4 **Hexagon Bolts (No. 28)**, 4 **Hex Lock Nuts (No. 27)**, 4 **Flat Washers (No. 30)** and 4 **Flat Big Washers (No. 31)**. Secure with 2 **Open End Wrenches (No. 32)**. Do not tighten the 4 **Hex Lock Nuts (No. 27)** during this step.

We value your experience using Sunny Health and Fitness products. For assistance with parts or troubleshooting, please contact us at [support@sunnyhealthfitness.com](mailto:support@sunnyhealthfitness.com) or 1-877-90SUNNY (877-907-8669).

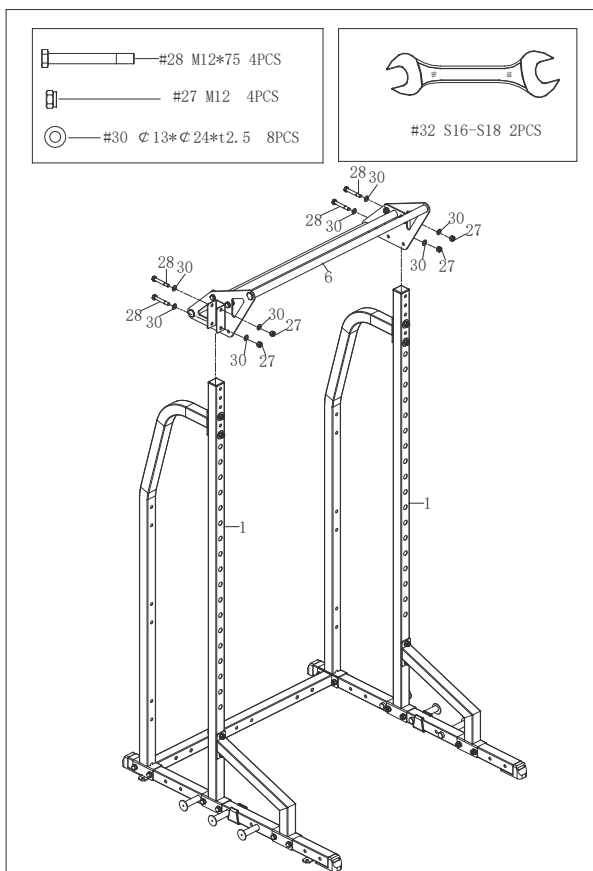

#### STEP 4:

Attach **Pull Up Bar (No. 6)** onto 2 **Upright Posts (No. 1)** using 4 **Hexagon Bolts (No. 28)**, 4 **Hex Lock Nuts (No. 27)** and 8 **Flat Washers (No. 30)**. Tighten and secure with 2 **Open End Wrenches (No. 32)**.



We value your experience using Sunny Health and Fitness products. For assistance with parts or troubleshooting, please contact us at [support@sunnyhealthfitness.com](mailto:support@sunnyhealthfitness.com) or 1-877-90SUNNY (877-907-8669).

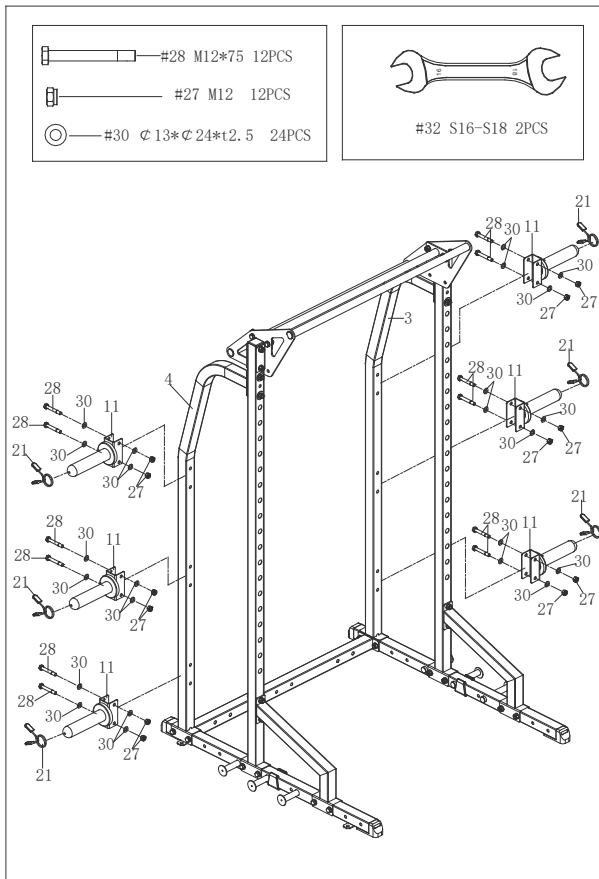

### STEP 5:

Insert 6 Counterweight Rods (No. 11) onto Left Support Frame (No. 3) and Right Support Frame (No. 4) using 12 Hexagon Bolts (No. 28), 12 Hex Lock Nuts (No. 27) and 24 Flat Washers (No. 30). Tighten and secure with 2 Open End Wrenches (No. 32).

We value your experience using Sunny Health and Fitness products. For assistance with parts or troubleshooting, please contact us at [support@sunnyhealthfitness.com](mailto:support@sunnyhealthfitness.com) or 1-877-90SUNNY (877-907-8669).

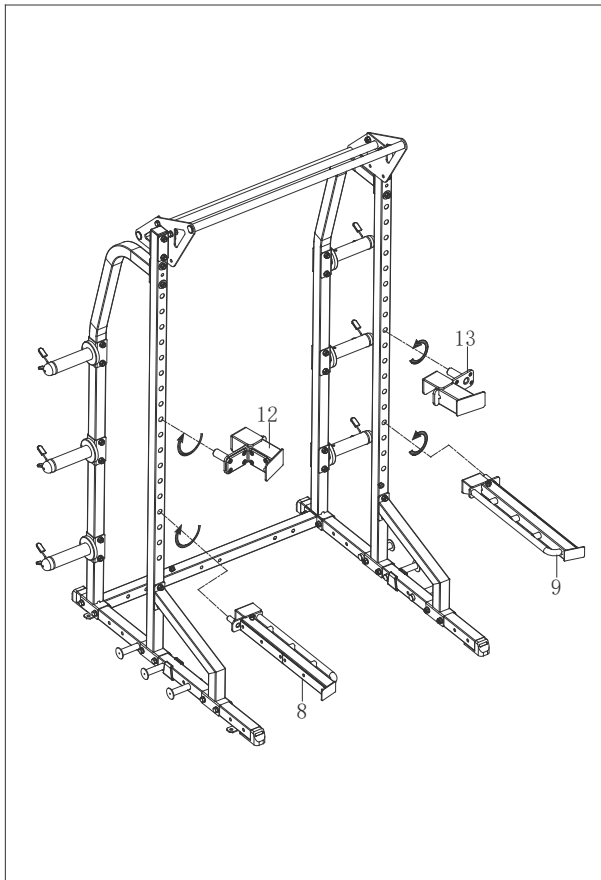

**STEP 6:**

Insert **Right Safety Bar (No. 8)** into **Upright Post (No. 1)** on the right. Turn the **Right Safety Bar (No. 8)** as the arrow showed on the left picture to tighten.

Insert **Left Safety Bar (No. 9)** into **Upright Post (No. 1)** on the left. Turn the **Left Safety Bar (No. 9)** as the arrow showed on the left picture to tighten.

Insert **Right Hook (No. 12)** into **Upright Post (No. 1)** on the right. Turn the **Right Hook (No. 12)** as the arrow showed on the picture to tighten.

Insert **Left Hook (No. 13)** into **Upright Post (No. 1)** on the left. Turn the **Left Hook (No. 13)** as the arrow showed on the left picture to tighten.

We value your experience using Sunny Health and Fitness products. For assistance with parts or troubleshooting, please contact us at [support@sunnyhealthfitness.com](mailto:support@sunnyhealthfitness.com) or 1-877-90SUNNY (877-907-8669).

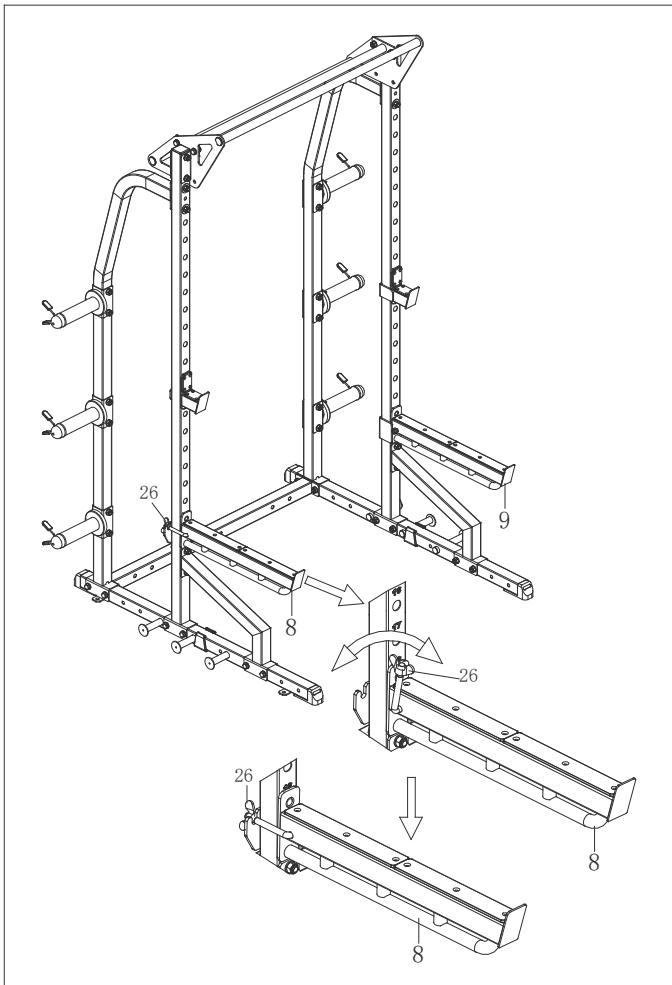

### STEP 7:

Turn the safety hooks on the **Left & Right Safety Bars (No. 9 & No. 8)** clockwise, then tighten the 2 **Butterfly Nuts (No. 26)** to avoid the safety tubes disconnecting from the posts while in use.

When adjusting the height of **Left & Right Safety Bars (No. 9 & No. 8)**, loosen the 2 **Butterfly Nuts (No. 26)**, then turn the safety hooks counter-clockwise.

We value your experience using Sunny Health and Fitness products. For assistance with parts or troubleshooting, please contact us at [support@sunnyhealthfitness.com](mailto:support@sunnyhealthfitness.com) or 1-877-90SUNNY (877-907-8669).

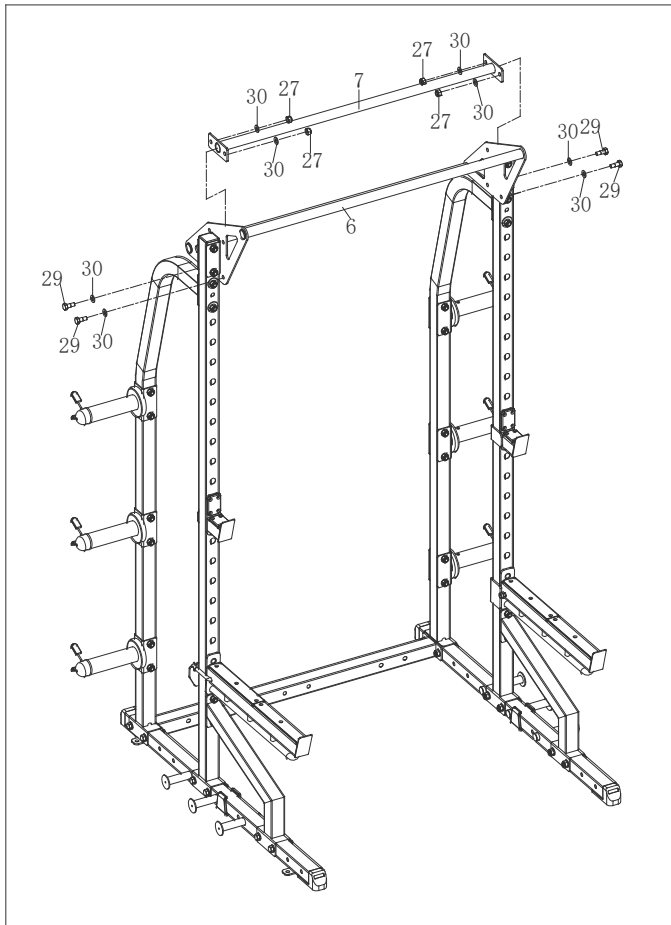

## STEP 8

According to the needs, attach the hole position of **Horizontal Bar (No. 7)** into **Pull Up Bar (No. 6)** secure with 4 **Hexagon Bolts (No. 29)**, 4 **Hex Lock Nuts (No. 27)** and 8 **Flat Washers (No. 30)**.

We value your experience using Sunny Health and Fitness products. For assistance with parts or troubleshooting, please contact us at [support@sunnyhealthfitness.com](mailto:support@sunnyhealthfitness.com) or 1-877-90SUNNY (877-907-8669).

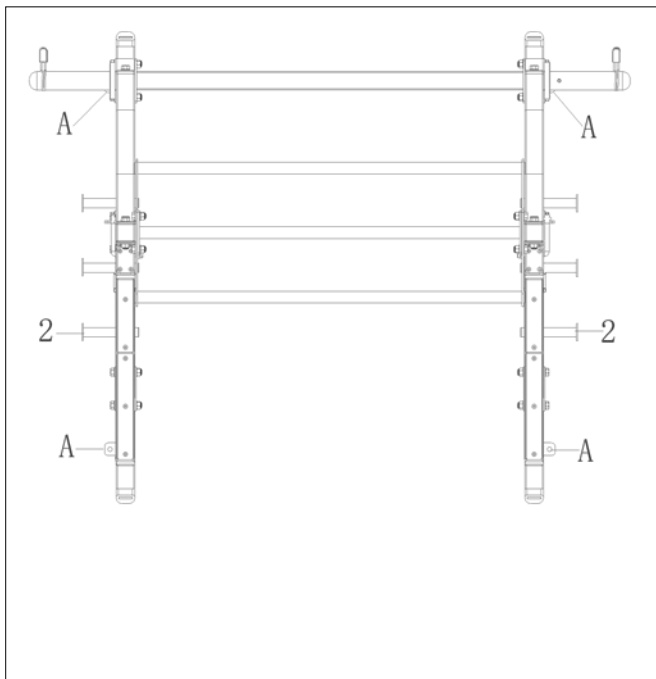

### STEP 9:

**WARNING:** Please ensure sufficient weights are on the power zone half rack strength cage and the power zone half rack strength cage is bolted to the ground before using the resistance bands.

**\*NOTE:** **Φ13 Wood Screws** and **Expansion Bolts** are not included.

If the ground is made of wood material, secure the 4 **Connecting Pieces (No. A)** on **Right & Left Stabilizers (No. 2)** to the ground using 4 **Φ13 Wood Screws** to bolt the power zone half rack strength cage.

If the ground is cement ground, please mark the holes on the 4 **Connecting Pieces (No. A)**, then remove the power zone half rack strength cage, drill the holes and install 4 **Expansion Bolts** into the ground. Move the power zone half rack strength cage back, align the holes with 4 **Connecting Pieces (No. A)** to the 4 **Expansion Bolts** and tighten them to bolt the power zone half rack strength cage.

*The assembly is complete!*

# **MAINTENANCE INSTRUCTIONS**

## **DAILY MAINTENANCE**

Inspect and tighten all parts regularly. (Nuts, Bolts, Rubber Pads, Steel Brackets, etc.)

Replace any worn or torn parts immediately.

Check and ensure the bench is levelled at all time.

Check and tighten all adjustment pins/knobs regularly.

## **WEEKLY MAINTENANCE**

Use damp cloth on plastic parts only, use dry cloth on metal frames.

Inspect the metal frame structure of the equipment.

Version: 1.1

# CONNECT WITH US

FOR FITNESS  
ARTICLES, VIDEOS  
& WORKOUTS



@SUNNYHEALTHANDFITNESS



@SUNNYHEALTHFITNESS



@SUNNYHEALTHFIT



/SUNNYHEALTHFITNESS



/SUNNYHEALTHANDFITNESS

WWW.SUNNYHEALTHFITNESS.COM