



# MULTI-WEIGHT STORAGE

## RACK STAND

SF-XF921036

USER MANUAL

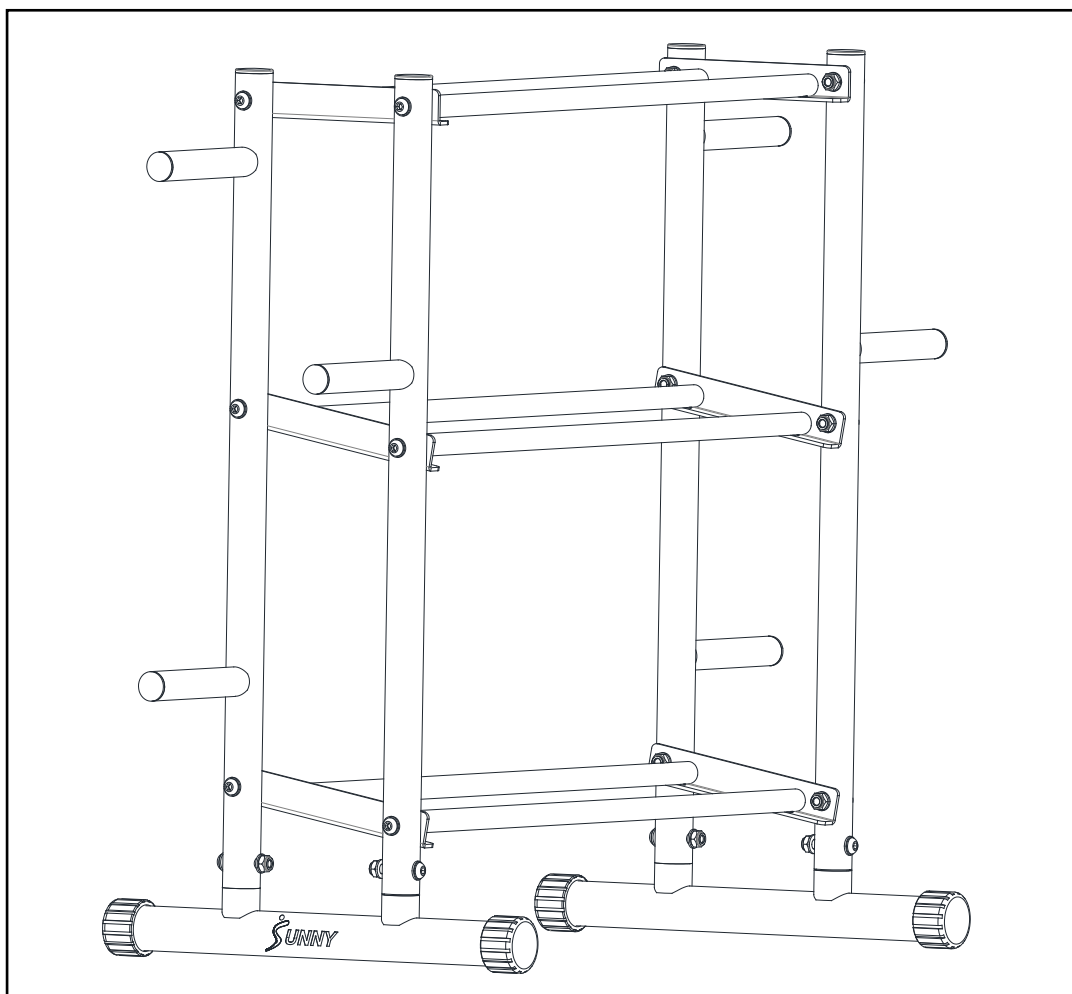

**IMPORTANT!** Please retain owner's manual for maintenance and adjustment instructions. Your satisfaction is very important to us, **PLEASE DO NOT RETURN UNTIL YOU HAVE CONTACTED US:** [support@sunnyhealthfitness.com](mailto:support@sunnyhealthfitness.com) or 1- 877 - 90SUNNY (877-907-8669).



WWW.SUNNYHEALTHFITNESS.COM

# **IMPORTANT SAFETY INFORMATION**





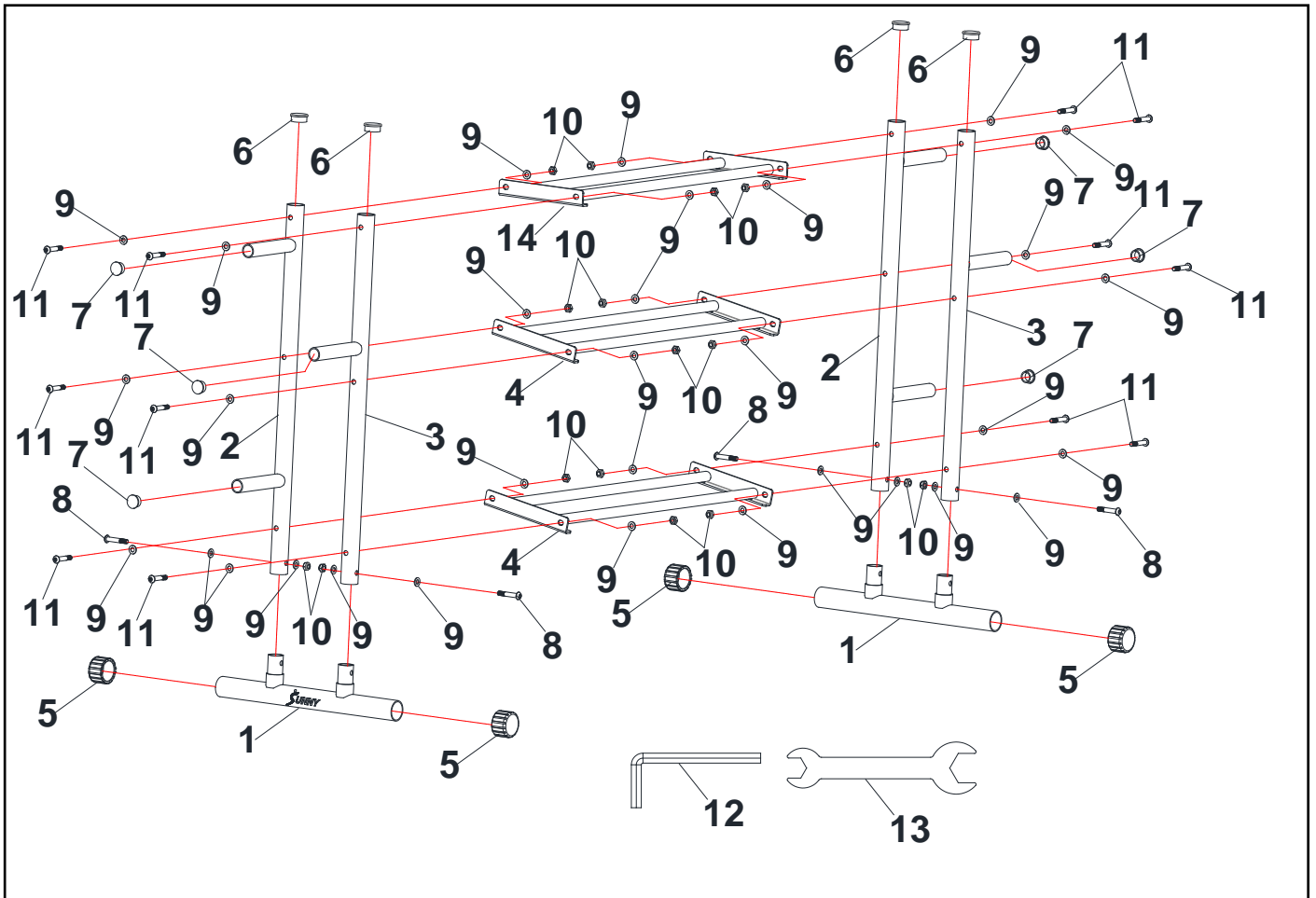

We thank you for choosing our product. To ensure your safety and health, please use this equipment correctly. It is important to read this entire manual before assembling and using the equipment. Safe and effective use can only be achieved if the equipment is assembled, maintained, and used properly. It is your responsibility to ensure that all users of the equipment are informed of all warnings and precautions.

1. Before starting any exercise program, you should consult your physician to determine if you have any medical or physical conditions that could put your health and safety at risk or prevent you from using the equipment properly. Your physician's advice is essential if you are taking medication that affects your heart rate, blood pressure, or cholesterol level.
2. Be aware of your body's signals. Incorrect or excessive exercise can damage your health. Stop exercising if you experience any of the following symptoms: pain, tightness in your chest, irregular heartbeat, shortness of breath, lightheadedness, dizziness, or feelings of nausea. If you do experience any of these conditions, you should consult your physician before continuing with your exercise program.
3. Keep children and pets away from the equipment. The equipment is designed for adult use only.
4. Use the equipment on a solid, flat level surface with a protective cover for your floor or carpet. To ensure safety, the equipment should have at least 2 feet (60 CM) of free space all around it.
5. Ensure that all nuts and bolts are securely tightened before using the equipment. The safety of the equipment can only be maintained if it is regularly examined for damage and/or wear and tear.
6. Always use the equipment as indicated. If you find any defective components while assembling or checking the equipment, or if you hear any unusual noises coming from the equipment during exercise, discontinue use of the equipment immediately and do not use until the problem has been rectified.
7. Wear suitable clothing while using the equipment. Avoid wearing loose clothing that may become entangled in the equipment.
8. Do not place fingers or objects into the moving parts of the equipment.
9. The maximum weight capacity of this unit is 835 pounds (380KG).
10. The equipment is not suitable for therapeutic use.
11. To avoid bodily injury and/or damage to the product or property, proper lifting and moving are required.
12. Your product is intended for use in cool and dry conditions. You should avoid storage in extreme cold, hot or damp areas as this may lead to corrosion and other related problems.
13. This equipment is designed for indoor and home use only; it is not intended for commercial use.

# EXPLODED DIAGRAM

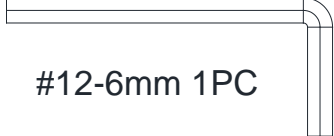

# HARDWARE PACKAGE

	#8-M8*45mm 4PCS		#13- #13-17mm 1PC
	#10-M8 16PCS		
	#11-M8*48mm 12PCS		#12-6mm 1PC
	#9- $\phi$ 16* $\phi$ 8.5*1.5mm 32PCS		

## **PARTS LIST**

No.	Description	Spec.	Qty.
1	Base Frame		2
2	Rear Upright Frame		2
3	Front Upright Frame		2
4	Black Support Frame		2
5	Round End Cap	φ 38	4
6	Round End Cap	φ 32*2.0	4
7	Round End Cap	φ 25*3.0	6

No.	Description	Spec.	Qty.
8	Hex Socket Head Bolt	M8*45mm	4
9	Flat Washer	φ 16* φ 8.5*1.5mm	32
10	Nylon Nut	M8	16
11	Hex Socket Head Bolt	M8*48mm	12
12	Allen Wrench	6mm	1
13	Wrench	#13-17	1
14	Red Support Frame		1

### **Ordering Replacement Parts (U.S. and Canadian Customers only)**

Please provide the following information in order for us to accurately identify the part(s) needed:

- ✓ The model number (found on cover of manual)
- ✓ The product name (found on cover of manual)
- ✓ The part number found on the “EXPLODED DIAGRAM” and “PARTS LIST” (found near the front of the manual)

Please contact us at [support@sunnyhealthfitness.com](mailto:support@sunnyhealthfitness.com) or 1- 877 - 90SUNNY (877-907-8669).

# ASSEMBLY INSTRUCTIONS

We value your experience using Sunny Health and Fitness products. For assistance with parts or troubleshooting, please contact us at [support@sunnyhealthfitness.com](mailto:support@sunnyhealthfitness.com) or 1-877-90SUNNY (877-907-8669).

## STEP 1:

Attach 2 **Rear Upright Frames (No. 2)** and 2 **Front Upright Frames (No. 3)** to 2 **Base Frames (No. 1)** respectively using 4 **Hex Socket Head Bolts (No. 8)**, 8 **Flat Washers (No. 9)** and 4 **Nylon Nuts (No. 10)**. Tighten and secure with 1 **Wrench (No. 13)** and 1 **Allen Wrench (No. 12)**.

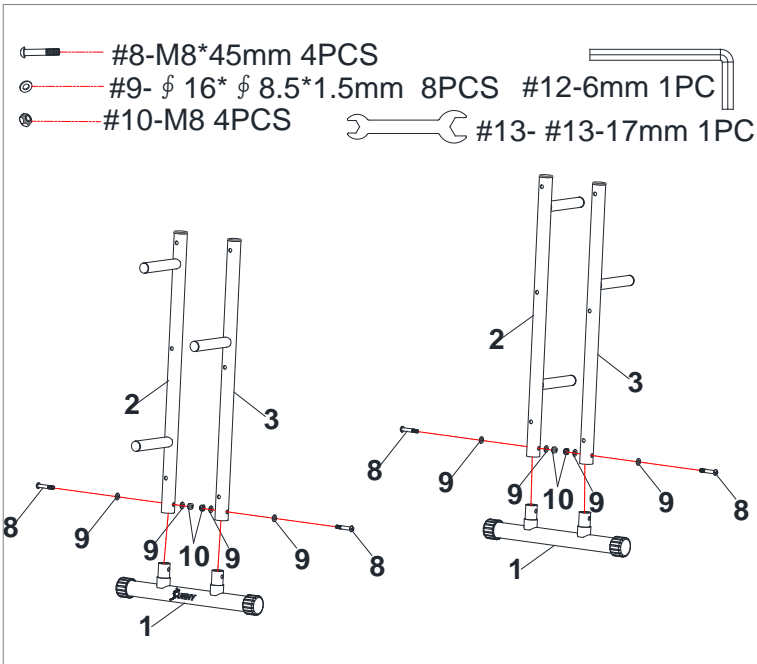

## STEP 2:

Attach 2 **Black Support Frames (No. 4)** and 1 **Red Support Frame (No. 14)** to 2 **Rear Upright Frames (No. 2)** and 2 **Front Upright Frames (No. 3)** using 12 **Hex Socket Head Bolts (No. 11)**, 24 **Flat Washers (No. 9)** and 12 **Nylon Nuts (No. 10)**. Tighten and secure with 1 **Wrench (No. 13)** and 1 **Allen Wrench (No. 12)**.

**NOTE:** The **Red Support Frame (No. 14)** should be on top

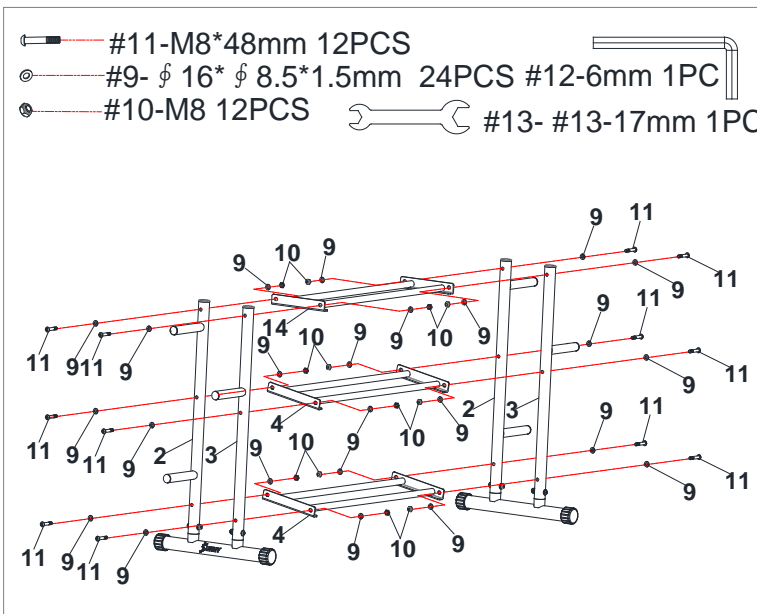

*The assembly is complete!*

# **MAINTENANCE INSTRUCTIONS**

## **DAILY MAINTENANCE**

Inspect and tighten all parts regularly. (Nuts, Bolts, Rubber Pads, Steel Brackets, etc.)

Replace any worn or torn parts immediately.

Check and ensure the equipment is levelled at all time.

Check and tighten all adjustment pins/knobs regularly.

## **WEEKLY MAINTENANCE**

Use damp cloth on plastic parts only, use dry cloth on metal frames.

Inspect the metal frame structure of the equipment.

# CONNECT WITH US

FOR FITNESS ARTICLES, VIDEOS & WORKOUTS



@SUNNYHEALTHANDFITNESS



@SUNNYHEALTHFITNESS



@SUNNYHEALTHFIT



/SUNNYHEALTHFITNESS



/SUNNYHEALTHANDFITNESS

WWW.SUNNYHEALTHFITNESS.COM