

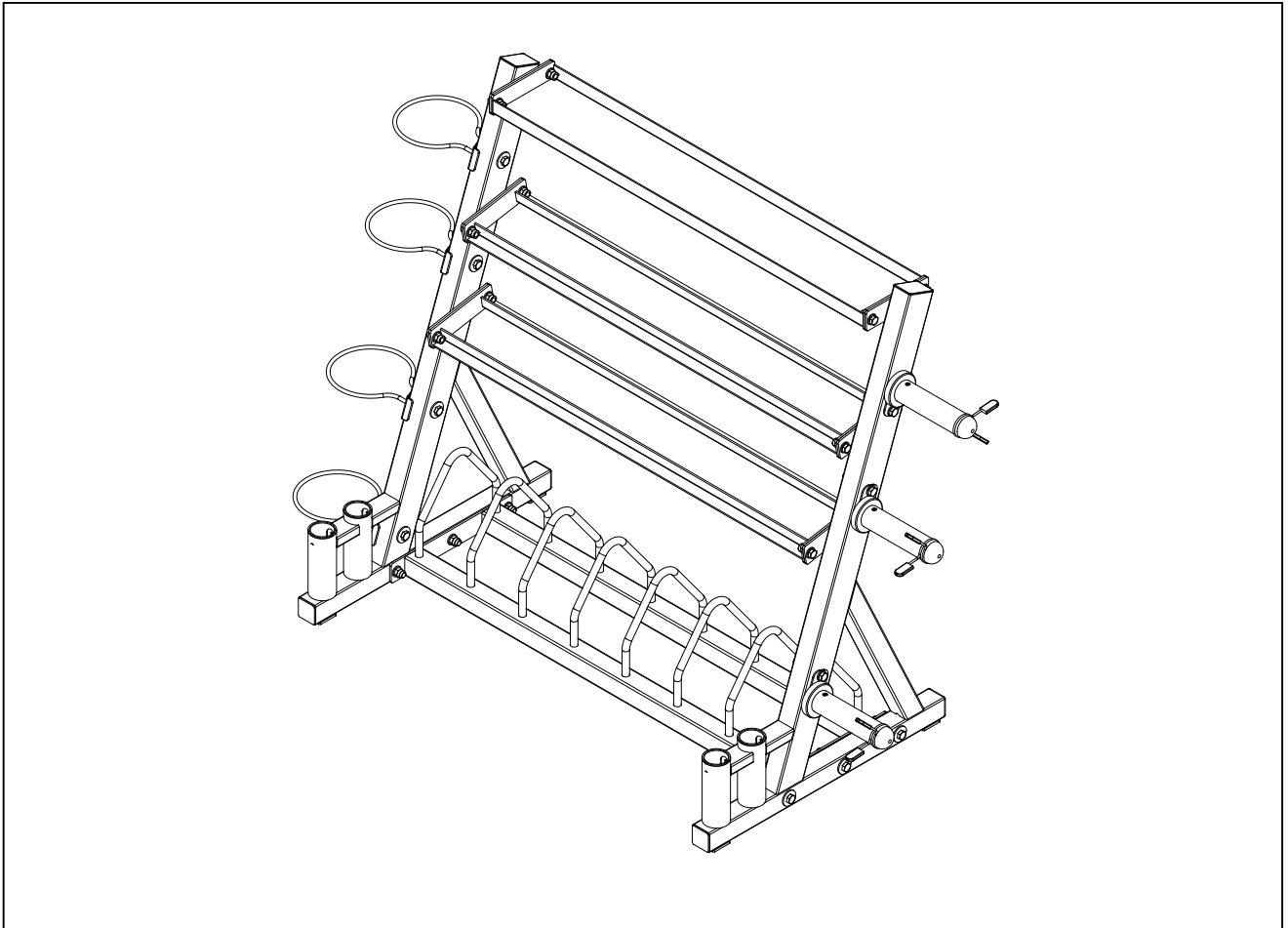

# MULTIFUNCTION WEIGHT & DUMBBELL RACK SF-XF920025 USER MANUAL



**IMPORTANT!** Please retain owner's manual for maintenance and adjustment instructions. Your satisfaction is very important to us, **PLEASE DO NOT RETURN UNTIL YOU HAVE CONTACTED US:** [support@sunnyhealthfitness.com](mailto:support@sunnyhealthfitness.com) or 1- 877 - 90SUNNY (877-907-8669).



WWW.SUNNYHEALTHFITNESS.COM

# **IMPORTANT SAFETY INFORMATION**

We thank you for choosing our product. To ensure your safety and health, please use this equipment correctly. It is important to read this entire manual before assembling and using the equipment. Safe and effective use can only be achieved if the equipment is assembled, maintained, and used properly. It is your responsibility to ensure that all users of the equipment are informed of all warnings and precautions.

1. Before starting any exercise program, you should consult your physician to determine if you have any medical or physical conditions that could put your health and safety at risk or prevent you from using the equipment properly. Your physician's advice is essential if you are taking medication that affects your heart rate, blood pressure, or cholesterol level.
2. Be aware of your body's signals. Incorrect or excessive exercise can damage your health. Stop exercising if you experience any of the following symptoms: pain, tightness in your chest, irregular heartbeat, shortness of breath, lightheadedness, dizziness, or feelings of nausea. If you do experience any of these conditions, you should consult your physician before continuing with your exercise program.
3. Keep children and pets away from the equipment. The equipment is designed for adult use only.
4. Use the equipment on a solid, flat level surface with a protective cover for your floor or carpet. To ensure safety, the equipment should have at least 2 feet (60 CM) of free space all around it.
5. Ensure that all nuts and bolts are securely tightened before using the equipment. The safety of the equipment can only be maintained if it is regularly examined for damage and/or wear and tear.
6. Always use the equipment as indicated. If you find any defective components while assembling or checking the equipment, or if you hear any unusual noises coming from the equipment during exercise, discontinue use of the equipment immediately and do not use until the problem has been rectified.
7. Wear suitable clothing while using the equipment. Avoid wearing loose clothing that may become entangled in the equipment.
8. Do not place fingers or objects into the moving parts of the equipment.
9. The maximum weight capacity of this stand is 2645 pounds (1200 KG). The equipment is not suitable for therapeutic use.
10. To avoid bodily injury and/or damage to the product or property, proper lifting and moving are required.
11. Your product is intended for use in cool and dry conditions. You should avoid storage in extreme cold, hot or damp areas as this may lead to corrosion and other related problems.
12. This equipment is designed for indoor and home use only; it is not intended for commercial use.

# EXPLODED DIAGRAM

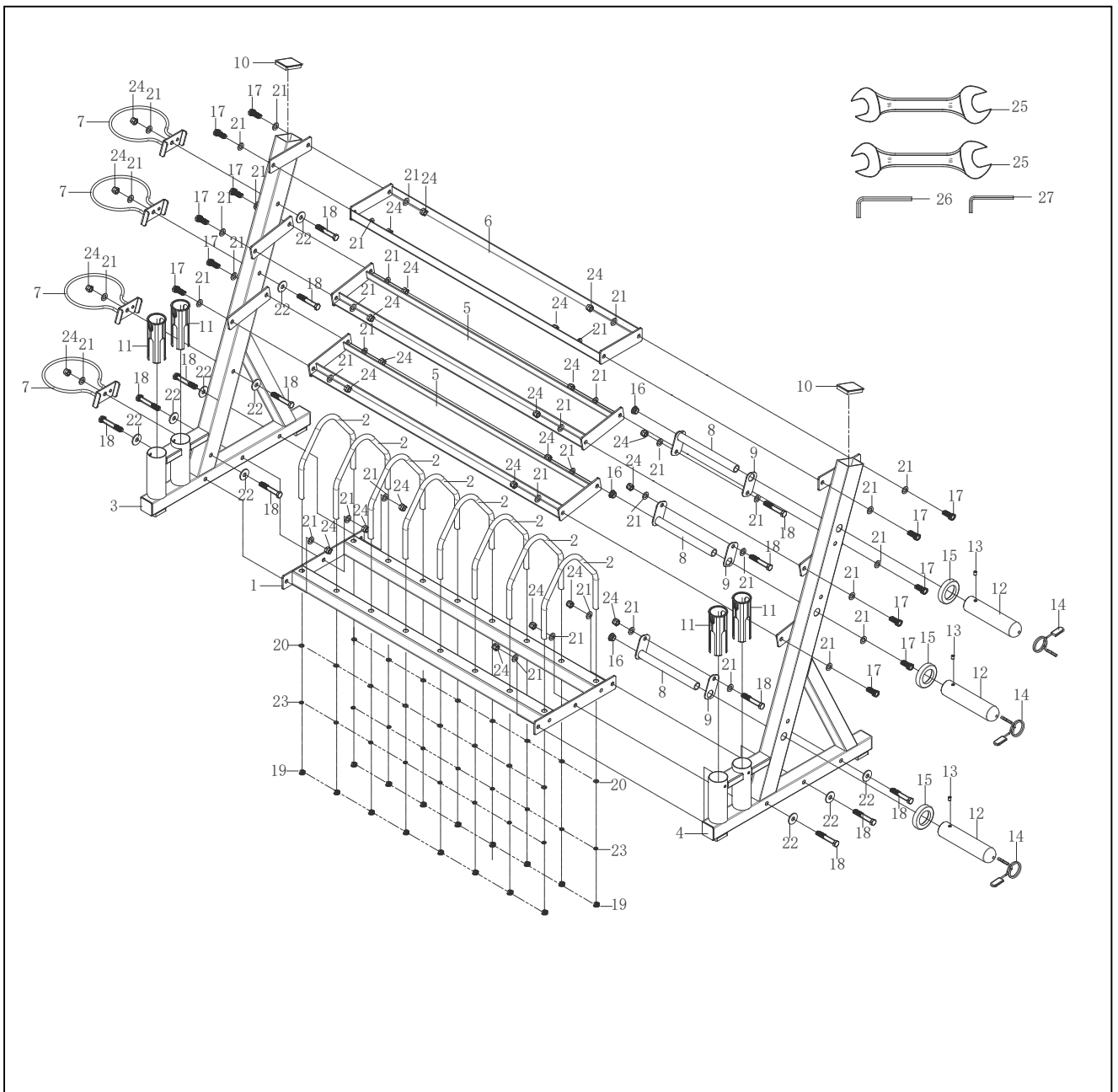

# PARTS LIST

NO.	Description	Spec	Qty.
1	Lower Connecting Frame		1
2	Fixed Frame		8
3	Right Shelf		1
4	Left Shelf		1
5	Middle Frame		2
6	Upper Connecting Frame		1
7	Ball Rack		4
8	Counterweight Hanging Rod		3
9	Fixed Piece	82*45*3.0	3
10	Rectangular Pipe Plug	75*50*2.0	2
11	Hollow Sleeve	∅ 60*t1.5* ∅ 50*152	4
12	Barbell Support Bar	∅ 100* ∅ 50*200	3
13	Screw	M8*8	3
14	Spring Clip	∅ 50	3

NO.	Description	Spec	Qty.
15	Cushion	∅ 80* ∅ 50*16	3
16	Round Inner Pipe Plug	∅ 25	3
17	Hex Bolt	M12*30	12
18	Hex Bolt	M12*75	13
19	Hex Bolt	M8*20	16
20	Flat Washer	∅ 8.4* ∅ 16*1.6	16
21	Flat Washer	∅ 13* ∅ 24*2.0	40
22	Big Flat Washer	∅ 13* ∅ 37*2.0	10
23	Spring Washer	∅ 8.1* ∅ 12.3*2.1	16
24	Lock Nut	M12	25
25	Open-End Wrench	S16-S18	2
26	Allen Wrench	5mm	1
27	Allen Wrench	4mm	1

# HARDWARE PACKAGE

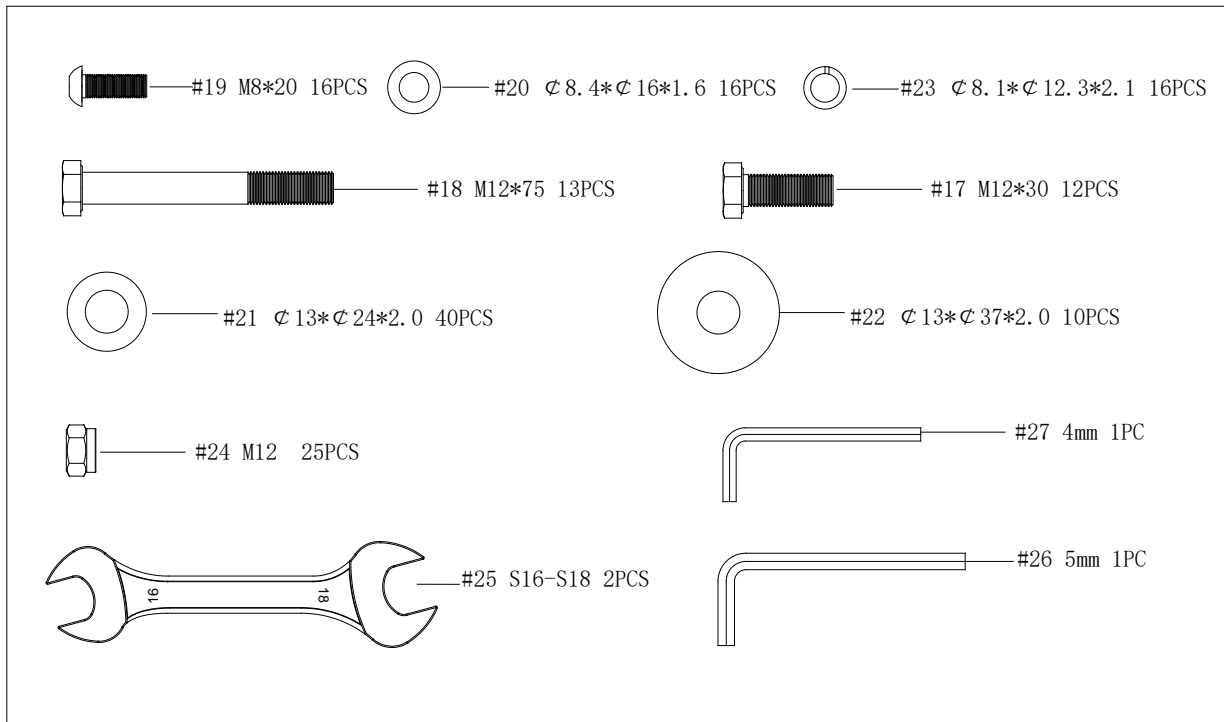

## Ordering Replacement Parts (U.S. and Canadian Customers only)

Please provide the following information in order for us to accurately identify the part(s) needed:

- ✓ The model number (found on cover of manual)
- ✓ The product name (found on cover of manual)
- ✓ The part number found on the “EXPLODED DIAGRAM” and “PARTS LIST” (found near the front of the manual)

Please contact us at [support@sunnyhealthfitness.com](mailto:support@sunnyhealthfitness.com) or 1-877-90SUNNY (877-907-8669).

# ASSEMBLY INSTRUCTIONS

We value your experience using Sunny Health and Fitness products. For assistance with parts or troubleshooting, please contact us at [support@sunnyhealthfitness.com](mailto:support@sunnyhealthfitness.com) or 1-877-90SUNNY (877-907-8669).

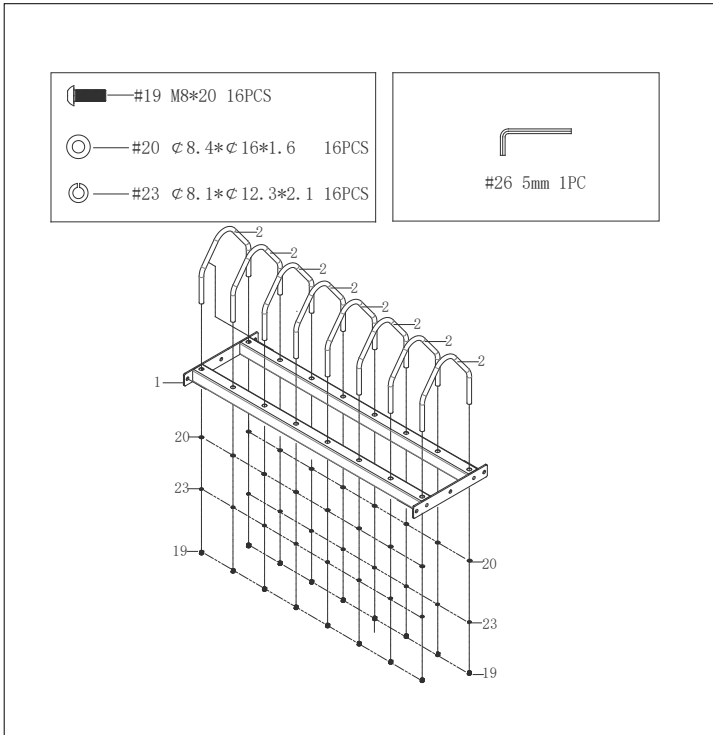

## STEP 1:

Attach 8 **Fixed Frame (No. 2)** onto the **Lower Connecting Frame (No. 1)**, using 16 **Flat Washers (No. 20)**, 16 **Spring Washers (No. 23)**, and 16 **Hex Bolts (No. 19)**. Tighten and secure with **Allen Wrench (No. 26)**.

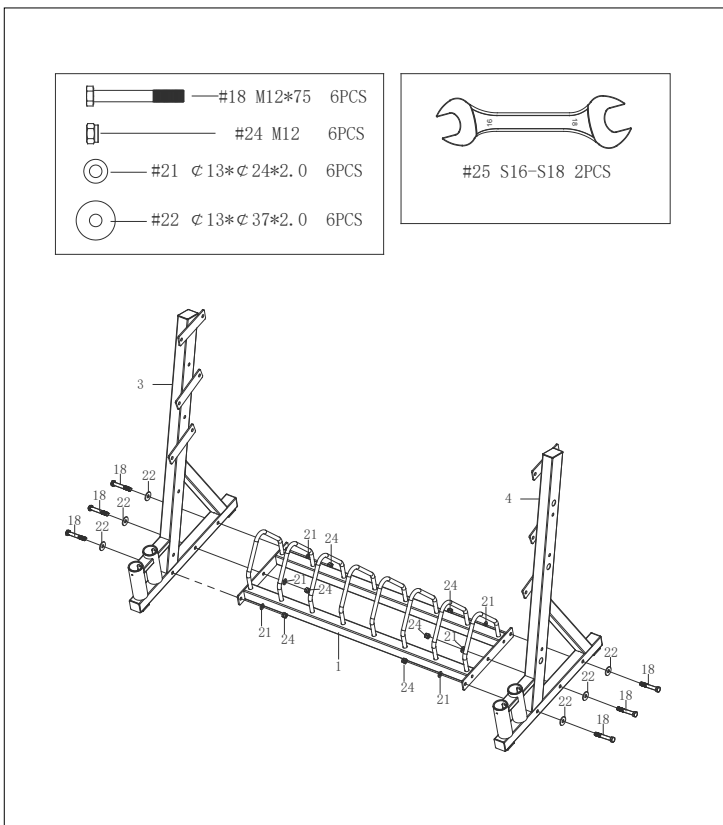

## STEP 2:

Attach the **Left Shelf (No. 4)** onto the left side of the **Lower Connecting Frame (No. 1)**, using 3 **Big Flat Washers (No. 22)**, 3 **Hex Bolts (No. 18)**, 3 **Flat Washers (No. 21)** and 3 **Lock Nuts (No. 24)**. Secure with 2 **Open-End Wrenches (No. 25)**. Do not tighten the **Hex Bolts (No. 18)** during this step.

Attach the **Right Shelf (No. 3)** onto the right side of the **Lower Connecting Frame (No. 1)**, using 3 **Big Flat Washers (No. 22)**, 3 **Hex Bolts (No. 18)**, 3 **Flat Washers (No. 21)** and 3 **Lock Nuts (No. 24)**. Secure with 2 **Open-End Wrenches (No. 25)**. Do not tighten the **Hex Bolts (No. 18)** during this step.

We value your experience using Sunny Health and Fitness products. For assistance with parts or troubleshooting, please contact us at [support@sunnyhealthfitness.com](mailto:support@sunnyhealthfitness.com) or 1-877-90SUNNY (877-907-8669).

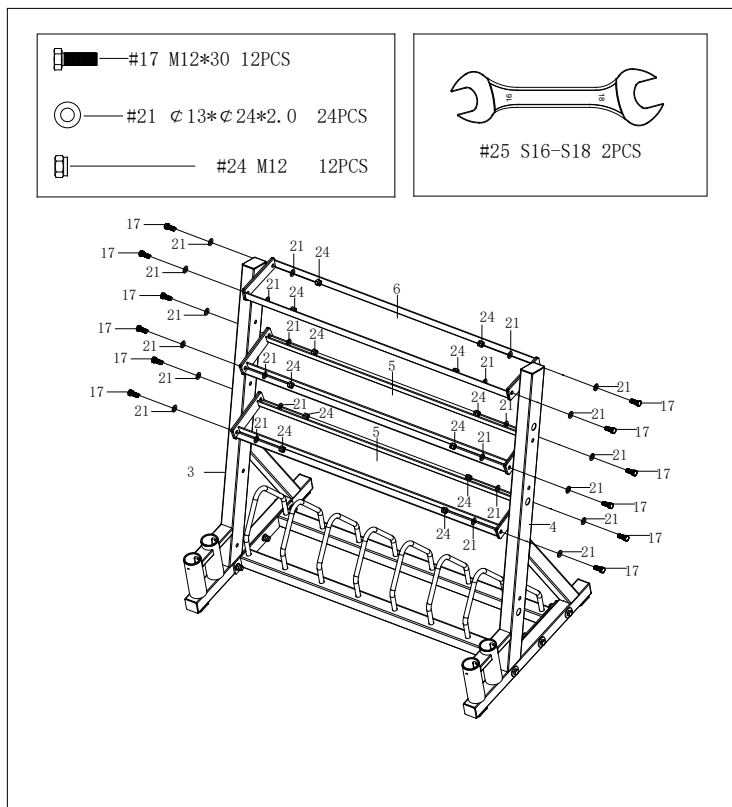

### STEP 3:

Attach the 2 connecting plates of the **Middle Frame (No. 5)** onto the connecting plates of the **Left Shelf (No. 4)** and **Right Shelf (No. 3)**, using 16 **Flat Washers (No. 21)**, 8 **Lock Nuts (No. 24)** and 8 **Hex Bolts (No. 17)**. Secure with 2 **Open-End Wrenches (No. 25)**. Do not tighten the **Hex Bolts (No. 17)** during this step.

Attach the connecting plates of the **Upper Connecting Frame (No. 6)** onto connecting plates of the **Left Shelf (No. 4)** and **Right Shelf (No. 3)**, using 8 **Flat Washers (No. 21)** and 4 **Lock Nuts (No. 24)** 4 **Hex Bolts (No. 17)**. Secure with 2 **Open-End Wrenches (No. 25)**. Then you can tighten all the **Hex Bolts (No. 17)** during this step.

Now you can tighten all the **Hex Bolts (No. 18)** from **STEP 2**.

We value your experience using Sunny Health and Fitness products. For assistance with parts or troubleshooting, please contact us at [support@sunnyhealthfitness.com](mailto:support@sunnyhealthfitness.com) or 1-877-90SUNNY (877-907-8669).

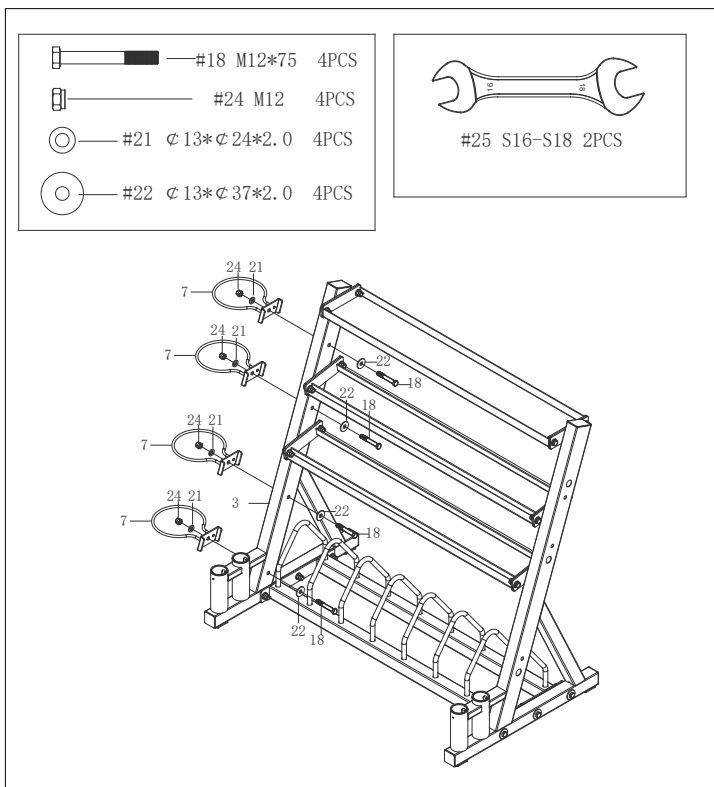

**STEP 4:**

Attach the 4 **Ball Racks (No. 7)** onto the **Left Shelf (No. 4)**, using 4 **Flat Washers (No. 21)**, 4 **Big Flat Washers (No. 22)**, 4 **Lock Nuts (No. 24)** and 4 **Hex Bolts (No. 18)**. Tighten and secure with 2 **Open-End Wrenches (No. 25)**.

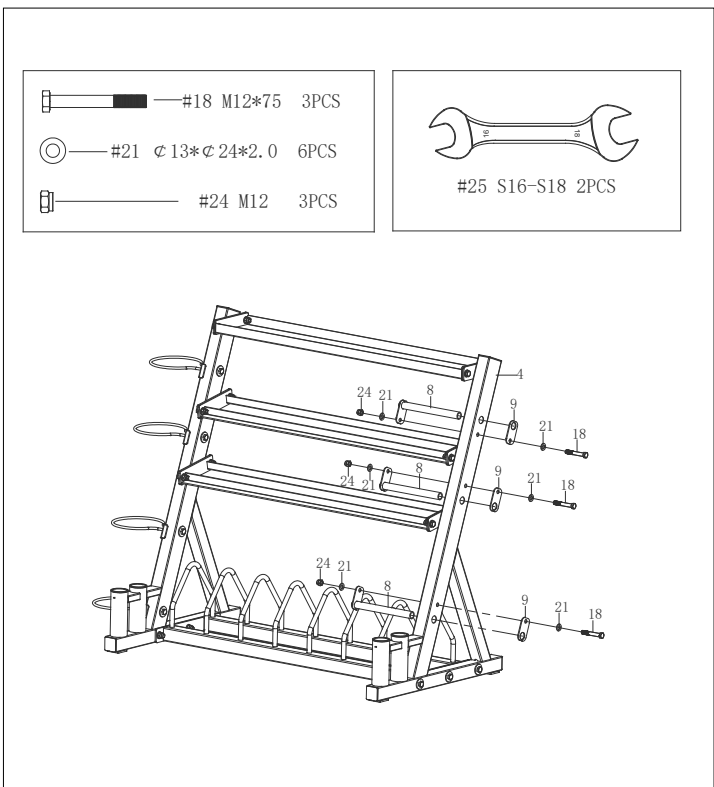

**STEP 5:**

Attach the 3 **Counterweight Hanging Rod (No. 8)** and 3 **Fixed Pieces (No. 9)** onto the **Right Shelf (No. 3)**, using 6 **Flat Washers (No. 21)**, 3 **Lock Nuts (No. 24)**, and 3 **Hex Bolts (No. 18)**. Tighten and secure with 2 **Open-End Wrenches (No. 25)**.



We value your experience using Sunny Health and Fitness products. For assistance with parts or troubleshooting, please contact us at [support@sunnyhealthfitness.com](mailto:support@sunnyhealthfitness.com) or 1-877-90SUNNY (877-907-8669).

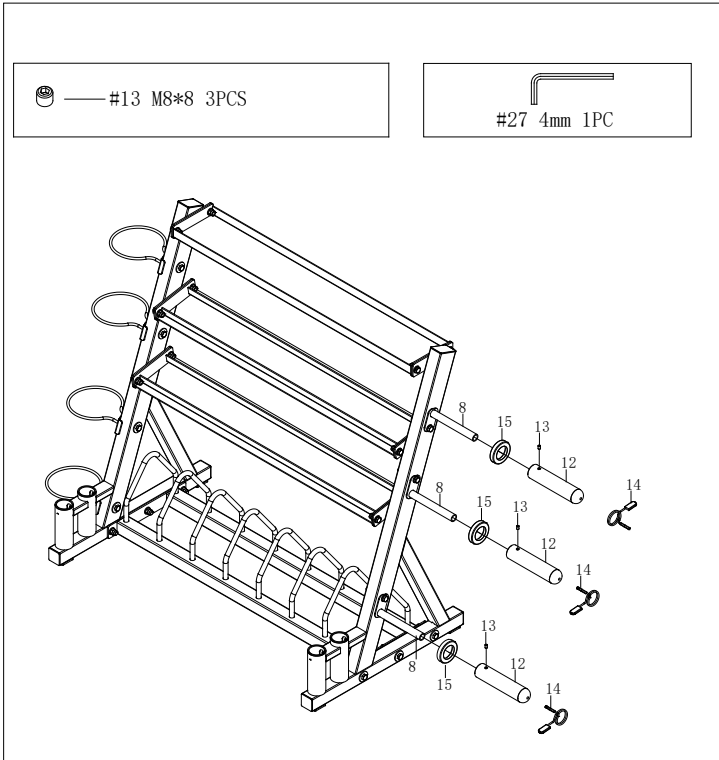

### STEP 6:

Attach the 3 **Cushions (No. 15)** and 3 **Barbell Support Bars (No. 12)** onto 3 **Counterweight Hanging Rods (No. 8)**, using 3 **Screws (No. 13)** to fix and lock 3 **Barbell Support Bars (No. 12)**, then install 3 **Spring Clips (No. 14)** into 3 **Barbell Support Bars (No. 12)**.

# **MAINTENANCE INSTRUCTIONS**

## DAILY MAINTENANCE

Inspect and tighten all parts regularly. (Nuts, Bolts, Rubber Pads, Steel Brackets, etc.)

Replace any worn or torn parts immediately.

Check and ensure the equipment is leveled at all time.

Check and tighten all adjustment pins/knobs regularly.

## WEEKLY MAINTENANCE

Use damp cloth on plastic parts only, use dry cloth on metal frames.

Inspect the metal frame structure of the equipment.

Version 1.1

# CONNECT WITH US

FOR FITNESS  
ARTICLES, VIDEOS  
& WORKOUTS



@SUNNYHEALTHANDFITNESS



@SUNNYHEALTHFITNESS



@SUNNYHEALTHFIT



/SUNNYHEALTHFITNESS



/SUNNYHEALTHANDFITNESS

[WWW.SUNNYHEALTHFITNESS.COM](http://WWW.SUNNYHEALTHFITNESS.COM)