

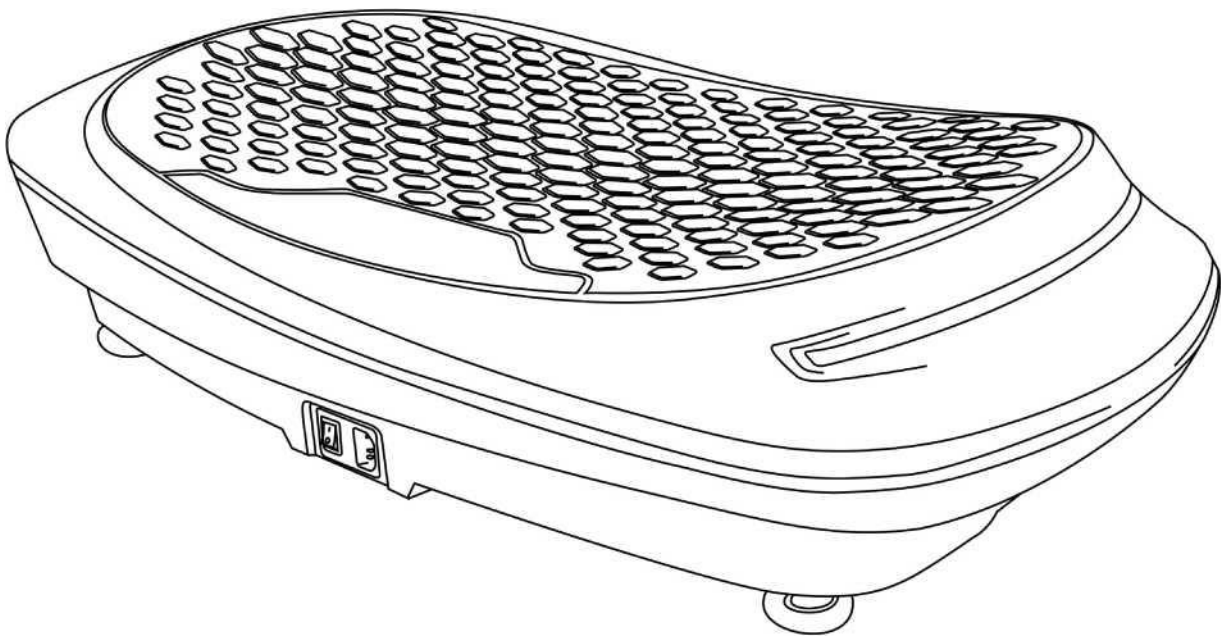

FITBOARD 4D VIBRATION PLATFORM EXERCISE MACHINE

SF-VP822058
USER MANUAL



IMPORTANT! Please retain owner's manual for maintenance and adjustment instructions. Your satisfaction is very important to us, **PLEASE DO NOT RETURN UNTIL YOU HAVE CONTACTED US:** support@sunnyhealthfitness.com or 1-877-90SUNNY (877-907-8669).



WWW.SUNNYHEALTHFITNESS.COM

IMPORTANT SAFETY INFORMATION

We thank you for choosing our product. To ensure your safety and health, please use this equipment correctly. It is important to read this entire manual before assembling and using the equipment. Safe and effective use can only be achieved if the equipment is assembled, maintained, and used properly. It is your responsibility to ensure that all users of the equipment are informed of all warnings and precautions. To reduce the risk of burns, fires, electric shock or personal injury, please read all instructions carefully before operating this product and keep this manual for future reference.

1. Before starting any exercise program, you should consult your physician to determine if you have any medical or physical conditions that could put your health and safety at risk or prevent you from using the equipment properly. Your physician's advice is essential if you are taking medication that affects your heart rate, blood pressure, or cholesterol level.
2. Be aware of your body's signals. Incorrect or excessive exercise can damage your health. Stop exercising if you experience any of the following symptoms: pain, tightness in your chest, irregular heartbeat, shortness of breath, lightheadedness, dizziness, or feelings of nausea. If you do experience any of these conditions, you should consult your physician before continuing with your exercise program.
3. Keep children and pets away from the equipment. The equipment is designed for adult use only.
4. Use the equipment on a solid, flat level surface with a protective cover for your floor or carpet. To ensure safety, the equipment should have at least 2 feet (60 CM) of free space all around it.
5. Ensure that all nuts and bolts are securely tightened before using the equipment. The safety of the equipment can only be maintained if it is regularly examined for damage and/or wear and tear.
6. Always use the equipment as indicated. If you find any defective components while assembling or checking the equipment, or if you hear any unusual noises coming from the equipment during exercise, discontinue use of the equipment immediately and do not use until the problem has been rectified.
7. Wear suitable clothing while using the equipment. Avoid wearing loose clothing that may become entangled in the equipment.
8. Do not place fingers or objects into the moving parts of the equipment.
9. The maximum weight capacity of this unit is 265 pounds (120 KG).
10. The equipment is not suitable for therapeutic use.
11. To avoid bodily injury and/or damage to the product or property, proper lifting and moving are required.
12. Your product is intended for use in cool and dry conditions. You should avoid storage in extreme cold, hot or damp areas as this may lead to corrosion and other related problems.
13. This equipment is designed for indoor and home use only; it is not intended for commercial use.

EXPLODED DIAGRAM 1

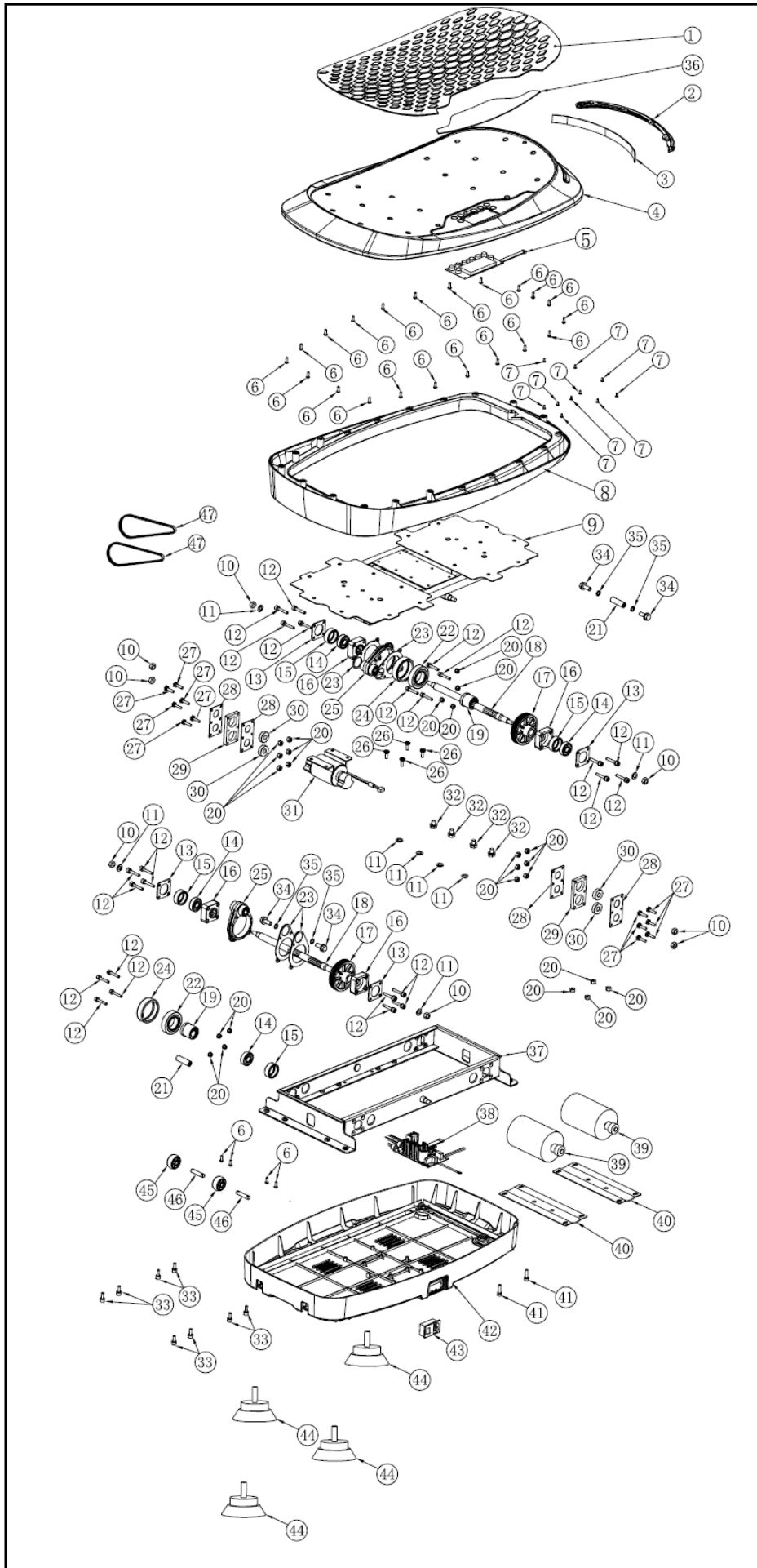

EXPLODED DIAGRAM 2

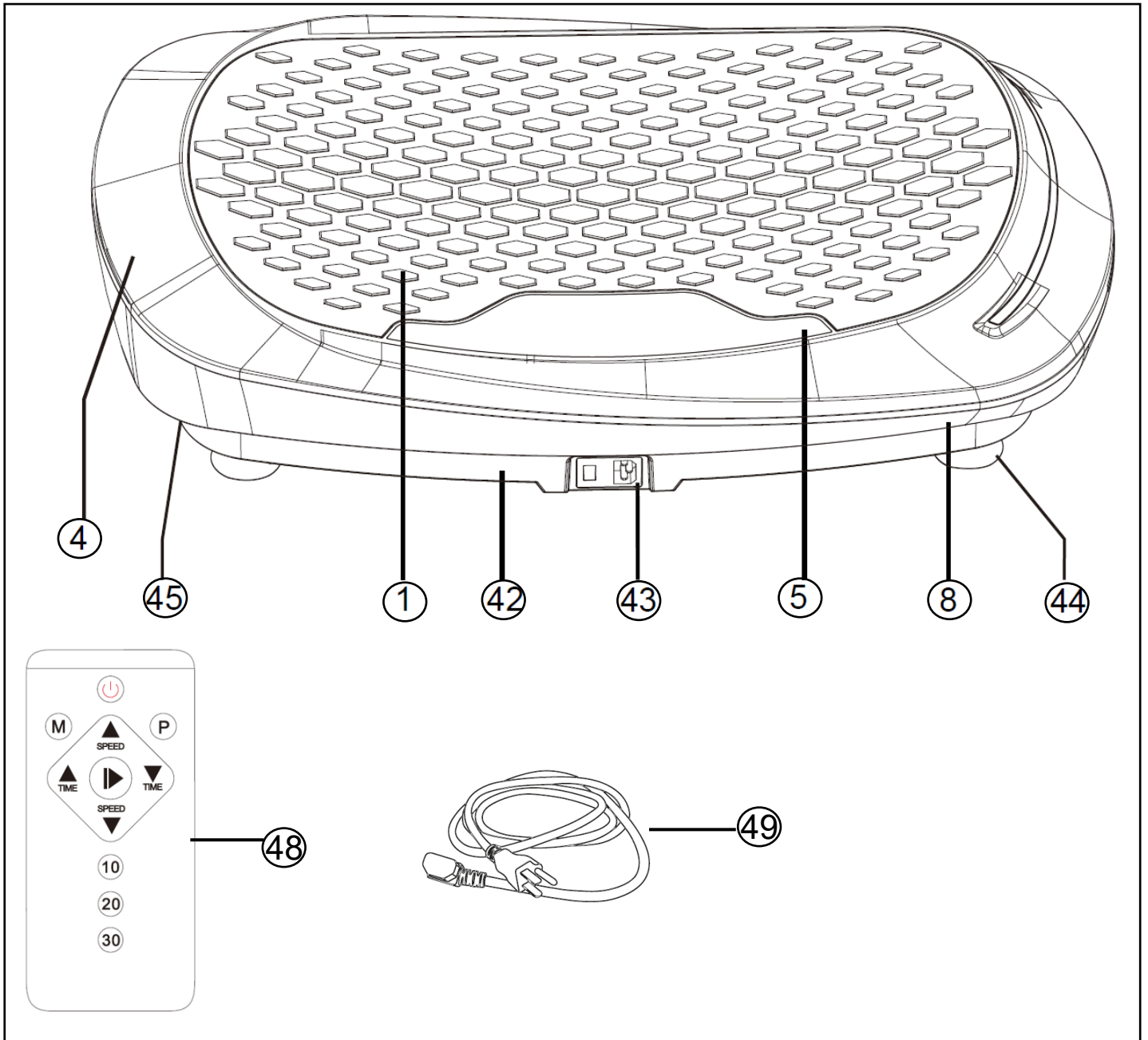

PARTS LIST

No.	Description	Spec.	Qty.	No.	Description	Spec.	Qty.
1	Stepping Rubber	631.7*354.3*3.7	1	26	Hexagon 3 in 1 Screw	M5*14	4
2	Light Cover	308.5*69.5*26.5	1	27	Hexagon Screw	M5*20	12
3	Light Strip	330*10	1	28	8 Type Connecting Gasket 2	75*40*1.5	4
4	Upper Cover	780*439.7*94	1	29	8 Type Connecting Rod 2	75*40*8	2
5	Upper Control Panel	130*65*21	1	30	Deep Groove Ball Bearing	6000	4
6	Cross Large Flat Head Self-Tapping Screw	ST4.0*16	25	31	53 Motor	90V 2600RPM	1
7	Cross Recessed Round Head Tapping Screw	ST3.0*8	10	32	Hexagon Screw	M8*12	4
8	Middle Cover	779.9*439.9*85.6	1	33	Hexagon Socket Head Screw	M5*14	8
9	Stepping Board	609.8*326*76.5	1	34	Hexagon Flange Screw	M8*20	4
10	Lock Nut	M8	8	35	Spring Washer	Φ8	4
11	Flat Washer	Φ16*Φ8*2.0	8	36	Acrylic Board	338*70*1	1
12	Hexagon Socket Head Bolt	M5*30	24	37	Bottom Frame	576*295*63	1
13	Bearing Base Cover	43*43*2.0	4	38	Base Control Panel	115*68*33	1
14	Deep Groove Ball Bearing	6201	4	39	Motor	90V 2700RPM	2
15	Bearing Shell	Φ35*13.5	4	40	Motor Frame	220*75*5	2
16	Bearing Base	43.5*43.5*19	4	41	Hexagon Socket Head Cap Screw	M6*20	2
17	Pulley	Φ75*Φ15*32	2	42	Bottom Shell	669.7*388.7*71	1
18	Long Axle	Φ15*279.6*M8	2	43	Switch	50*31*23	1
19	Eccentric Block	Φ32.3*Φ15*30	2	44	Foot Pad	Φ53*32*M6	4
20	Flange Lock Nut	M5	24	45	Transportation Wheel	Φ8.3*39	2
21	Pin	40.5*12*M8	2	46	Wheel Axle		2
22	Deep Groove Ball Bearing	6006	2	47	Belt		2
23	8 Type Connecting Gasket	92*65*2.0	4	48	Remote Control	102*47*10	1
24	Bearing Cover	Φ58.1*16	2	49	Power Cord	1.5m	1
25	8 Type Connecting Rod	94.9*41.7	2				

Ordering Replacement Parts (U.S. and Canadian Customers only)

Please provide the following information in order for us to accurately identify the part(s) needed:

- ✓ The model number (found on cover of manual)
- ✓ The product name (found on cover of manual)
- ✓ The part number found on the “EXPLODED DIAGRAM” and “PARTS LIST” (found near the front of the manual)

Please contact us at support@sunnyhealthfitness.com or 1-877-90SUNNY (877-907-8669).

ASSEMBLY CONTENTS

WHEN OPENING THE CARTON, THE FOLLOWING PARTS CAN BE FOUND:

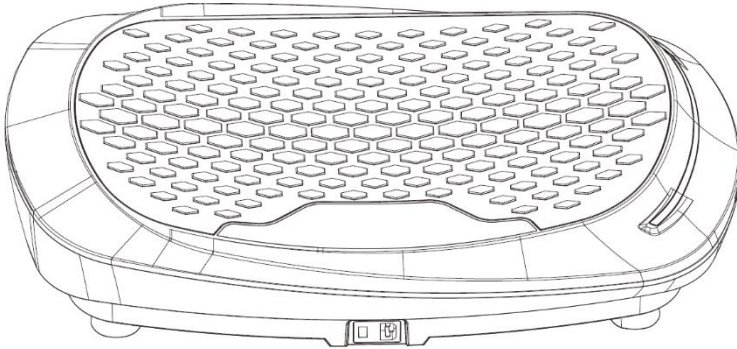

Main Product

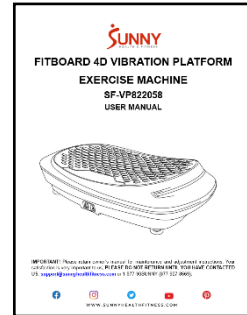

Manual

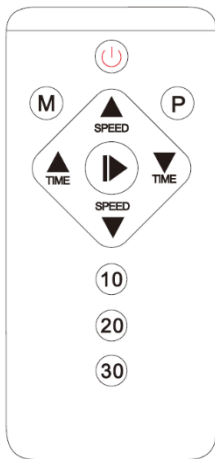

Remote Control



Button Cell Battery



Thank You Card

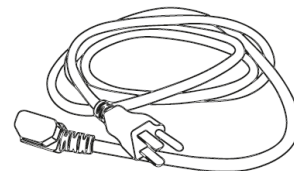

Power Cord

IMPORTANT ELECTRICAL INFORMATION

IMPORTANT NOTE: This machine requires a power source of **110 Volts** in order to properly operate. For your safety, as well as the safety of others, please verify that the power source is correct before powering the machine. Any power supply source above or below this level could cause significant damage to the machine and/or user.

GROUNDING METHODS:

This machine must be grounded. Should the machine malfunction or breakdown, grounding provides a path of least resistance for electric current to reduce the risk of electric shock. This machine is equipped with a plug that has an equipment-grounding conductor and a grounding plug. The plug must be plugged into an appropriate outlet that is properly installed and grounded in accordance with all local codes and ordinances.

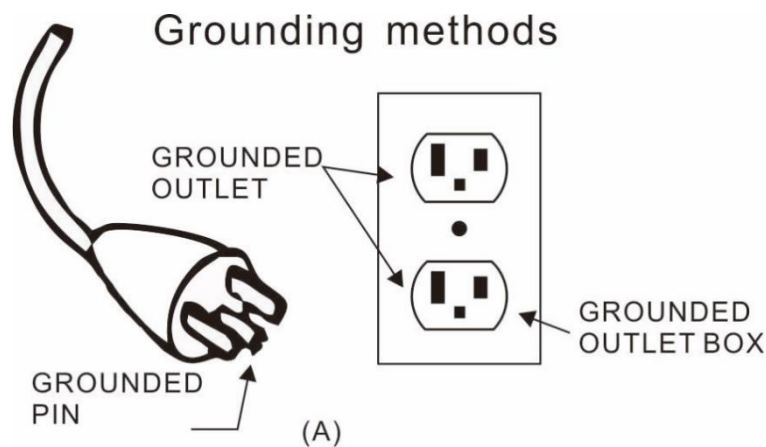

CAUTION:

Improper connection of the machine can result in the risk of electric shock. Check with a qualified electrician or serviceman if you are unsure whether the machine has been properly grounded. Do not modify the plug provided with this machine. If it will not fit the outlet, have a proper outlet installed by a qualified electrician. Ensure that the machine is connected to an outlet with the same configuration as the plug. Do not use an adaptor for this machine.

WARNING!

1. **NEVER** use a ground fault circuit interrupt (GFCI) outlet with this machine. Route the power cord away from all moving parts of the machine, including the transportation wheels.
2. **NEVER** operate the machine using a generator or UPS power supply.
3. **NEVER** remove any cover on this machine without first disconnecting the power cord.
4. **NEVER** expose the machine to rain or moisture. This machine is not designed for outdoor use or use in any high humidity environment.

BATTERY INSTALLATION AND REPLACEMENT

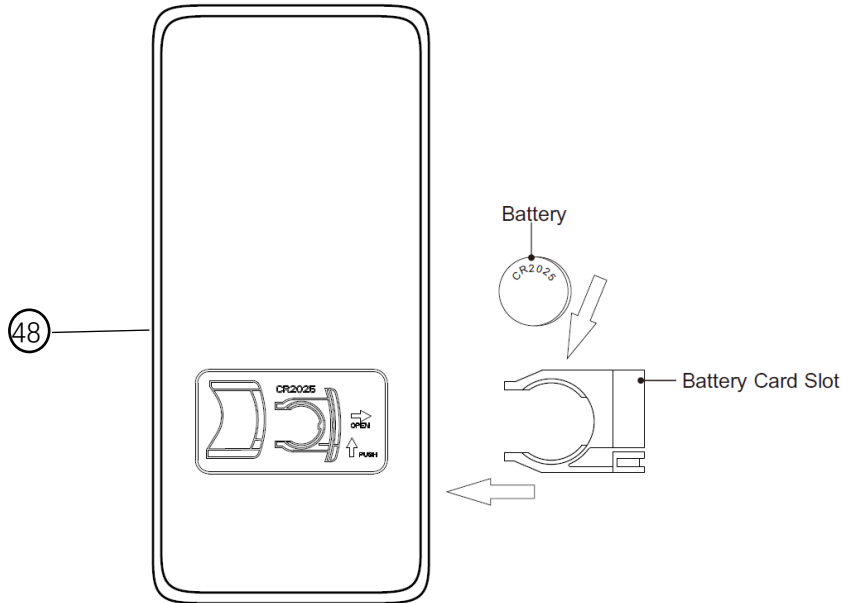

BATTERY INSTALLATION:

1. Remove the battery card slot from the **Remote Control (No. 48)**.
2. Take out the 1 pc battery that is included inside the remote control plastic bag.
3. Install the battery into the battery card slot with the CR2025 side facing up.
4. Push the battery card slot back into the **Remote Control (No. 48)**.

The installation is complete!

BATTERY REPLACEMENT:

1. Remove the battery card slot from the **Remote Control (No. 48)**.
2. Take out the old battery from battery card slot and install the new battery into the battery card slot with the CR2025 side facing up.
3. Push the battery card slot back into the **Remote Control (No. 48)**.

The replacement is complete!

Dispose of the old battery according to your state or regional guidelines.

BATTERY REQUIREMENTS:

⚠ WARNING: Chemical Burn Hazard. Keep battery away from children.

This product contains a coin cell battery. If a new or used coin cell battery is swallowed or enters the body, it can cause severe internal burns and can lead to death in as little as 2 hours. Always completely secure the battery compartment. If the battery compartment does not close securely, stop using the product, remove the battery, and keep it away from children. If you think the battery might have been swallowed or placed inside any part of the body, seek immediate medical attention.

- a) The coin cell battery should be disposed of properly, including keeping them away from children.
- b) Even used coin cell battery may cause injury.

For household use only.





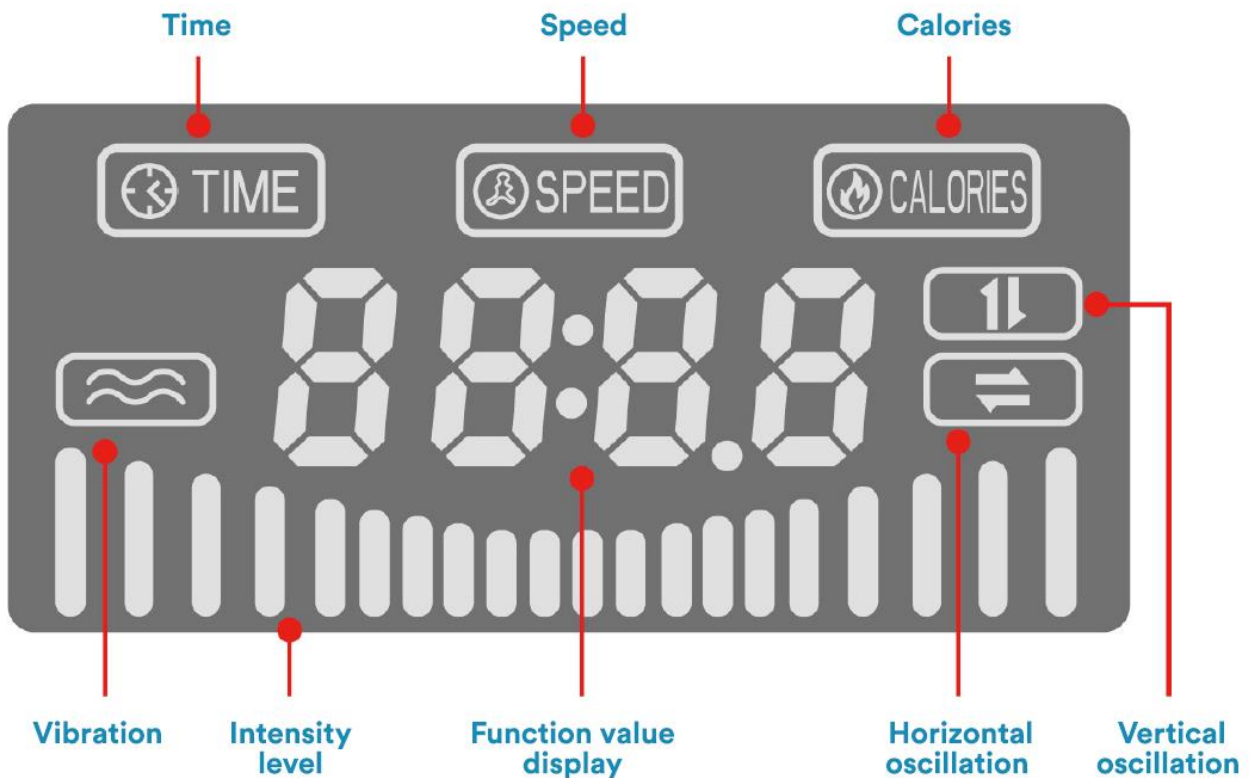
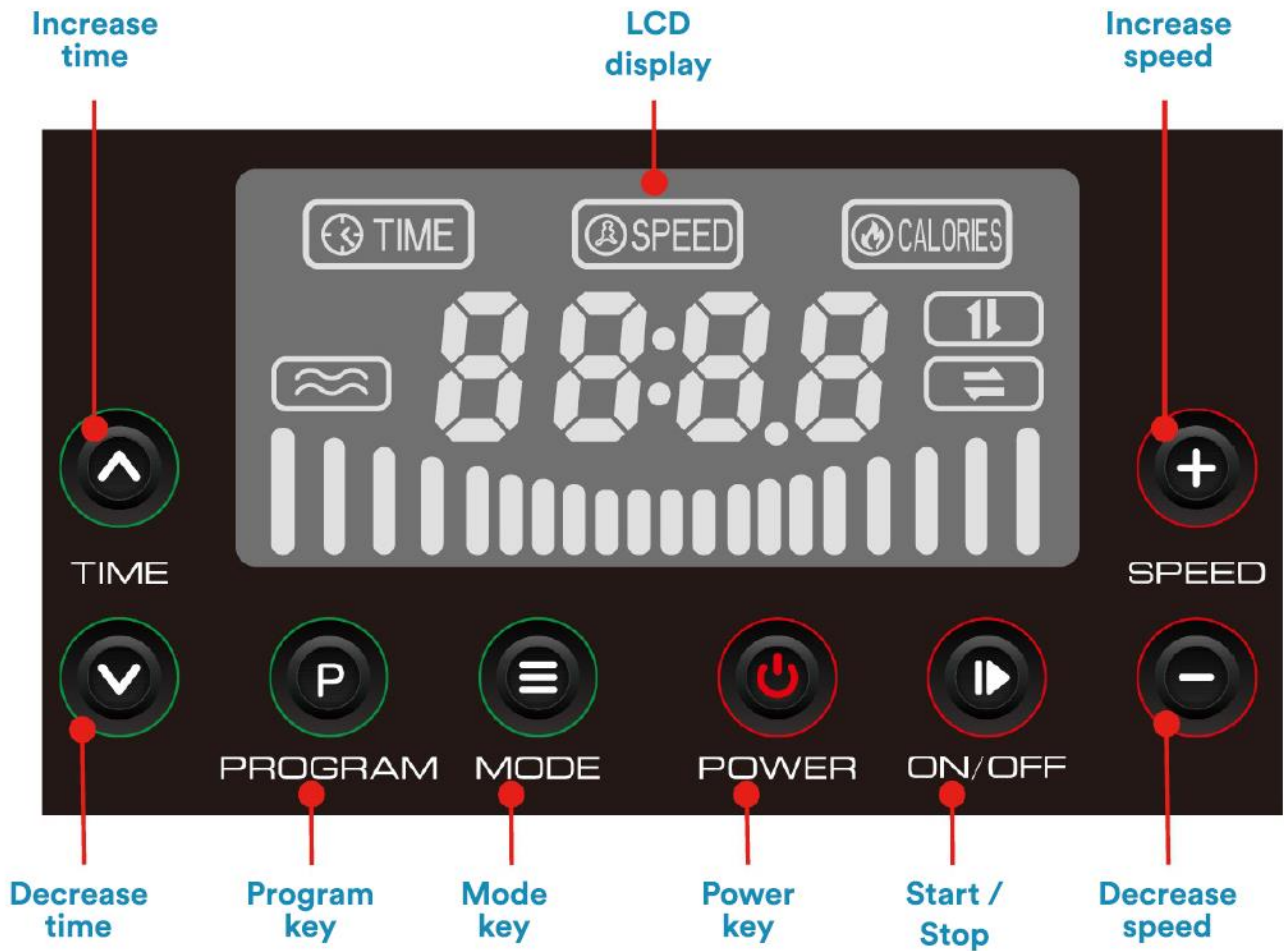



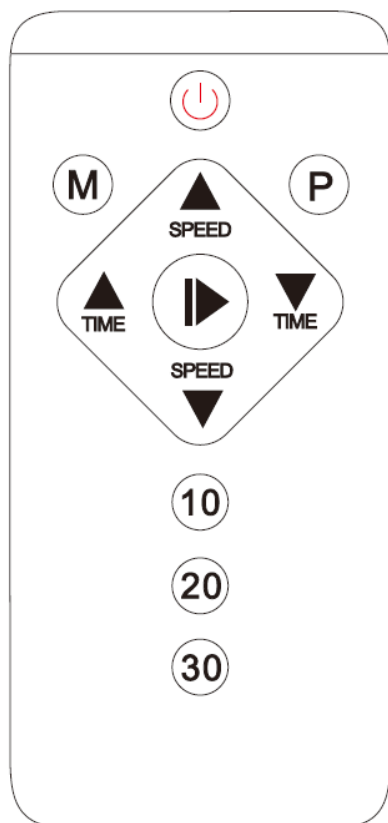

THE DISPLAY CONSOLE

OPERATING THE CONTROL UNIT



OPERATING THE REMOTE CONTROL



-  Power key
-  Start/Stop
-  Increase speed
-  Decrease speed
-  Increase time
-  Decrease time
-  Mode key
-  Program key
-  Quick adjustment for speed, level 10 in manual mode
-  Quick adjustment for speed, level 20 in manual mode
-  Quick adjustment for speed, level 30 in manual mode

To start the unit, please connect the **Power Cord (No. 49)** to a power supply, then turn on the **Switch (No. 43)** on the main product and press the Power key. Now the machine would be in standby mode. You can start training in manual mode by pressing the Start/Stop key or you can select a program by pressing the Program key.

The default time for a workout is 10 minutes, after 10 minutes, the workout will end automatically. To switch off the machine, press the Power key (after the end of the training session) and then turn off the **Switch (No. 43)** on the main product.

Increase/Decrease Time: You can preset the workout time, ranging from 1 to 10 minutes by pressing the Increase/Decrease keys. If you do not set any time, the machine will run for 10 minutes.

Increase/Decrease Speed: You may set the speed in 30 steps (level 1-30). The speed setting does not work in programs (P1/P2/P3). In programs (P1/P2/P3), the speed is controlled automatically.

Mode Key: The machine has various movement modes. In manual mode, you can select the movement by pressing the Mode key. You can see which mode is currently active on the console display.

Modes	Movements
1st	Vertical Oscillation
2nd	Horizontal Oscillation
3rd	Vibration Mode
4th	Vertical & Horizontal Oscillation
5th	Vertical Oscillation & Vibration
6th	Horizontal Oscillation & Vibration
7th	All Movement Mode

Start/Stop: If you press the Start/Stop key, the machine starts moving after a 3 second countdown. When pressed again, the machine stops moving.

Power Key: Always switch off the machine with the Power key after the end of the training session. You can also switch the machine off with the Power key when it is in motion. The machine will switch to standby mode if there is not any training or input. Press the Power key to reactivate the machine.

PROGRAMS

The machine has three programs: P1, P2 and P3. You can choose the program with the Program key. Each program has a fixed moving time of 6 minutes and 40 seconds. The speed is set automatically (see Fig. 1). Each step takes 20 seconds. The difference between the programs is the type of movement.

- P1:** Vertical oscillation
- P2:** Horizontal oscillation
- P3:** Vibration

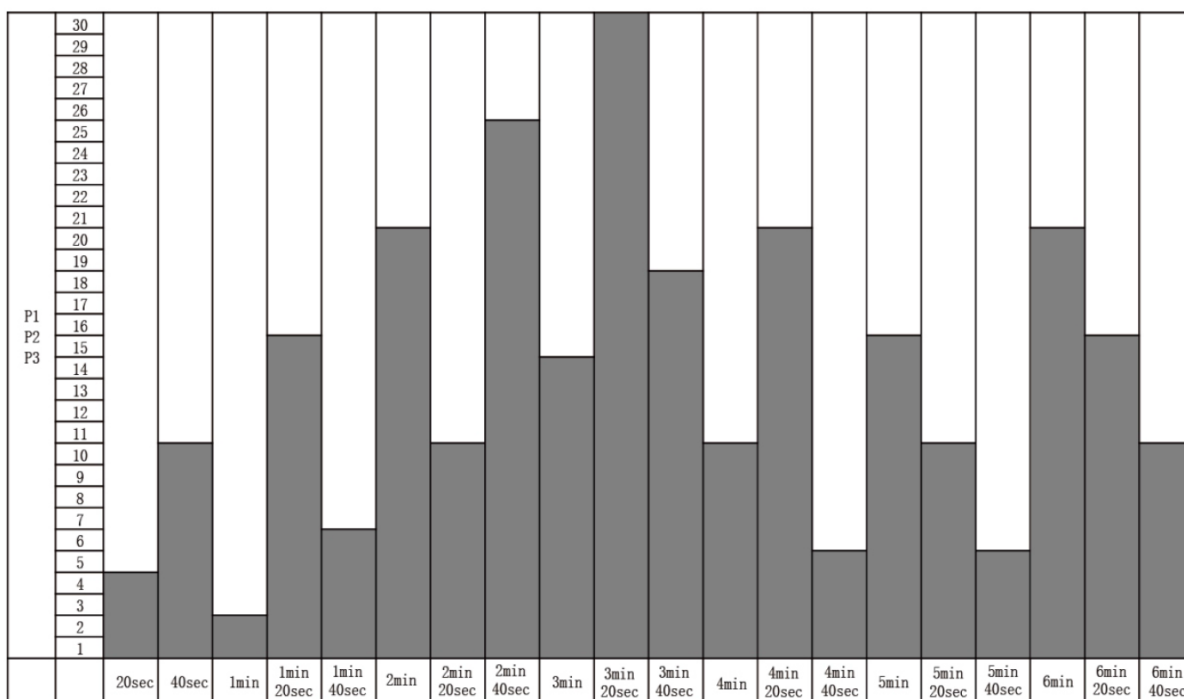

Fig. 1

TROUBLESHOOTING

1. The machine does not start:

Check plug (power connection) and check if the Power switch is switched on.

2. Remote control does not work:

Replace battery and check if the distance between remote control and the machine is less than max. 2 meters.

3. Other, abnormal behavior:

Disconnect the power supply, wait for 2 minutes, reconnect the power supply, then restart the machine.

Error codes: E01/E05: Signal error; E02: Vertical motor error; E04: Overvoltage protection triggered; E06: Vibration motor error; E08: Horizontal motor error.

If the problem cannot be solved with the above troubleshooting, contact customer service at support@sunnyhealthfitness.com or 1-877-90SUNNY (877-907-8669).

USAGE INSTRUCTIONS

1. Sit on the **Stepping Rubber (No. 1)** with your back straight and put your hands on your knees. This exercise aims to relax the hips and buttocks. (Fig. 2)

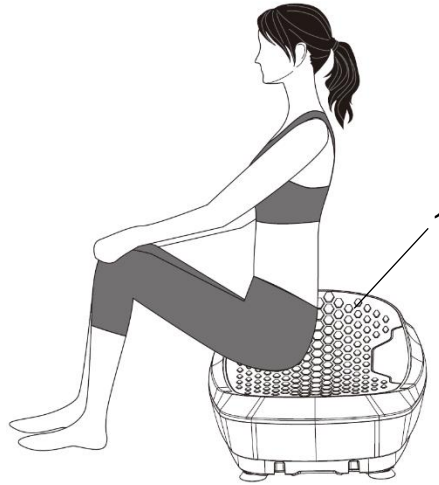

Fig. 2

2. Sit in front of the machine, keep your back straight and place your feet on the **Stepping Rubber (No. 1)** while supporting yourself with your hands at the sides. This exercise relaxes the leg muscles. (Fig. 3)

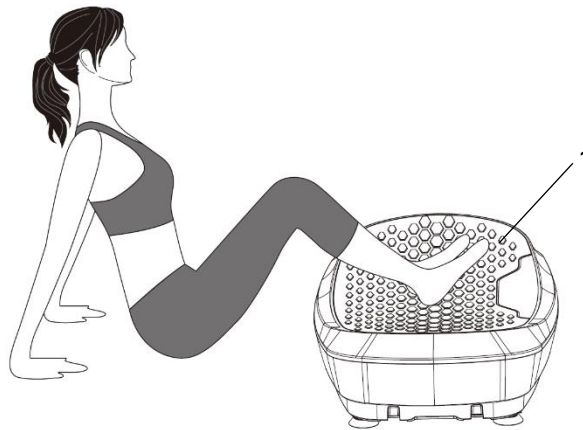

Fig. 3

3. Exercise for shoulders and arms: Kneel on the floor and support yourself with your hands about shoulder width on the **Stepping Rubber (No. 1)**. Your body should be leaning slightly forward. (Fig. 4)

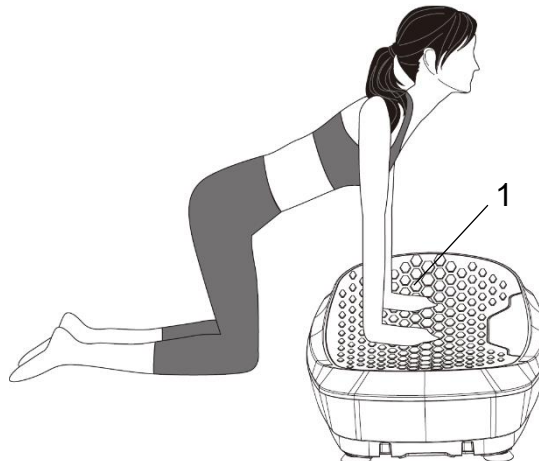

Fig. 4

4. Sit on a chair in front of the machine and place your feet on the **Stepping Rubber (No. 1)** for a relaxing vibration massage. This exercise is good for the lower and upper thighs. (Fig. 5)

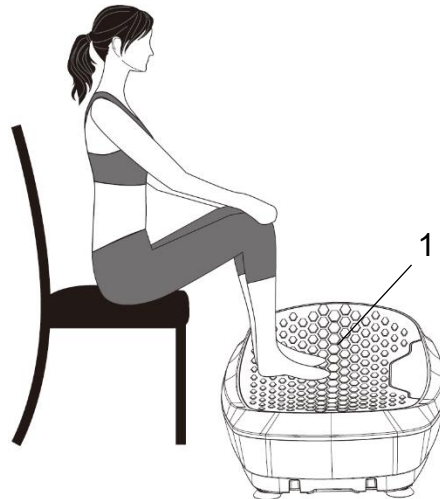

Fig. 5

5. Transport the machine: lift the opposite side of the **Transportation Wheel (No. 45)** until the **Transportation Wheel (No. 45)** touches the ground. With the **Transportation Wheel (No. 45)** touching the ground, you can transport the machine.

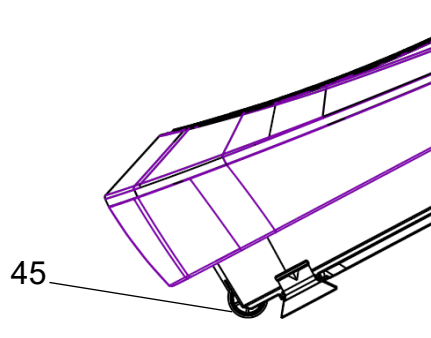

Fig. 6

MAINTENANCE GUIDE

Cleaning the machine:

- Make sure that the machine is switched off and the plug is disconnected before you begin. Allow the machine to cool down.
- Clean the machine with a slightly damp cloth only. Never use brushes, aggressive cleaning agents, petrol, thinners, or alcohol. Rub the machine dry with a clean dry cloth.
- Never immerse the machine in water to clean it and ensure water cannot get into the machine.
- Wait until the machine is completely dry before using it again.
- Take care when rolling up the power cord to avoid damaging it.
- You should ideally store the machine in its original packaging and keep it in a clean, dry place.
- You can also clean the remote control with a slightly moistened cloth. Remove the battery first before you begin. Be careful not to swallow the battery and keep it in a safe place! Allow the remote control to dry completely before replacing the battery.

Caution: The user is cautioned that changes or modifications not expressly approved by the party responsible for compliance could void the user's authority to operate the equipment.

This device complies with Part 15 of the FCC Rules. Operation is subject to the following two conditions: (1) this device may not cause harmful interference, and (2) this device must accept any interference received, including interference that may cause undesired operation.

NOTE: This equipment has been tested and found to comply with the limits for a Class B digital device, pursuant to Part 15 of the FCC Rules. These limits are designed to provide reasonable protection against harmful interference in a residential installation. This equipment generates, uses and can radiate radio frequency energy and, if not installed and used in accordance with the instructions, may cause harmful interference to radio communications. However, there is no guarantee that interference will not occur in a particular installation.

If this equipment does cause harmful interference to radio or television reception, which can be determined by turning the equipment off and on, the user is encouraged to try to correct the interference by one or more of the following measures:

- Reorient or relocate the receiving antenna.
- Increase the separation between the equipment and receiver.
- Connect the equipment into an outlet on a circuit different from that to which the receiver is connected.
- Consult the dealer or an experienced radio/TV technician for help.

FCC Radiation Exposure Statement

This equipment complies with FCC radiation exposure limits set forth for an uncontrolled environment. This equipment should be installed and operated with a minimum distance of 20cm between the radiator and your body.

This transmitter must not be co-located or operating in conjunction with any other antenna or transmitter.

CONNECT WITH US

FOR FITNESS ARTICLES, VIDEOS & WORKOUTS



@SUNNYHEALTHANDFITNESS



@SUNNYHEALTHFITNESS



@SUNNYHEALTHFIT



/SUNNYHEALTHFITNESS



/SUNNYHEALTHANDFITNESS



@SUNNYHEALTHFITNESS

WWW.SUNNYHEALTHFITNESS.COM