

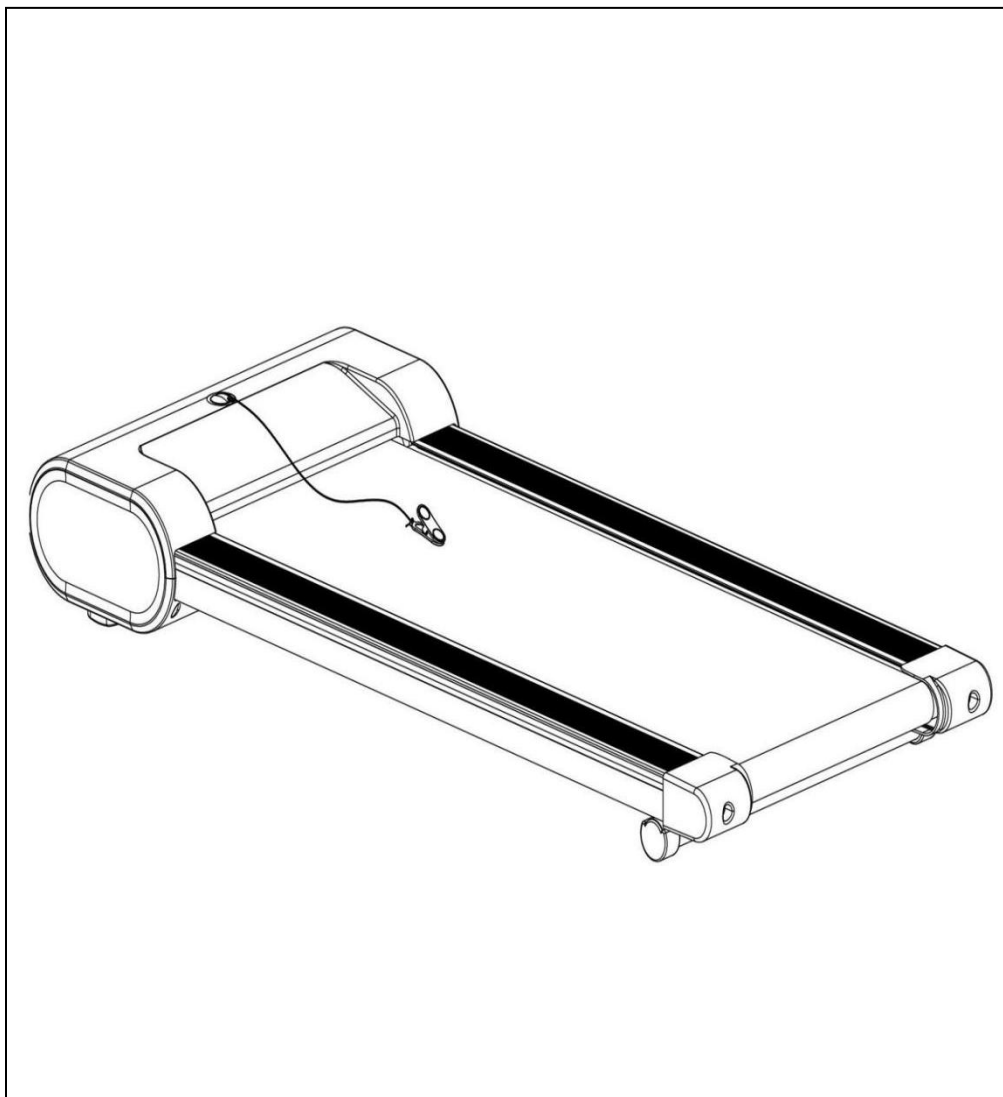

# WALKSTATION SLIM TREADMILL

## SF-T7945

### USER MANUAL



**IMPORTANT!** Please retain owner's manual for maintenance and adjustment instructions. Your satisfaction is very important to us, **PLEASE DO NOT RETURN UNTIL YOU HAVE CONTACTED US:** [support@sunnyhealthfitness.com](mailto:support@sunnyhealthfitness.com) or 1- 877 - 90SUNNY (877-907-8669).



# **IMPORTANT SAFETY INSTRUCTION**

When using an electrical appliance, basic precautions should always be followed, including the following:

Read all instructions before using this treadmill.

**DANGER**– To reduce the risk of electrical shock:

Always unplug this appliance from the electrical outlet immediately after using and before cleaning.

**WARNING** – To reduce the risk of burns, fire, electric shock, or injury to persons:

1. The treadmill should never be left unattended when plugged in. Unplug from the outlet when not in use and before putting on or removing parts.
2. Use this treadmill only for its intended use as described in this manual. Do not use attachments not recommended by the manufacturer.
3. Never operate this treadmill if it has a damaged cord or plug, if it is not working properly, if it has been dropped or damaged, or dropped into water. Return this treadmill to a service center for examination or repair.
4. Keep the cord away from heated surfaces.
5. Never operate the treadmill with the air openings blocked. Keep the air openings free of lint, hair, and alike items.
6. Never drop or insert any object into any opening.
7. Do not use outdoors.
8. Do not operate where aerosol (spray) products are being used or where oxygen is being administered.
9. To disconnect, turn the treadmill off, then remove plug from outlet.
10. Connect this treadmill to a properly grounded outlet only. See grounding instructions.

## **CAUTION:**

To avoid injury, use extreme caution when stepping onto or off of a moving belt. Read instruction manual before using.

*SAVE THESE INSTRUCTIONS*

# **IMPORTANT SAFETY INFORMATION**

We thank you for choosing our product. To ensure your safety and health, please use this equipment correctly. It is important to read this entire manual before assembling and using the equipment. Safe and effective use can only be achieved if the equipment is assembled, maintained, and used properly. It is your responsibility to ensure that all users of the equipment are informed of all warnings and precautions.

1. Before starting any exercise program, you should consult your physician to determine if you have any medical or physical conditions that could put your health and safety at risk or prevent you from using the equipment properly. Your physician's advice is essential if you are taking medication that affects your heart rate, blood pressure or cholesterol level.
2. Be aware of your body's signals. Incorrect or excessive exercise can damage your health. Stop exercising if you experience any of the following symptoms: pain, tightness in your chest, irregular heartbeat, shortness of breath, lightheadedness, dizziness, or feelings of nausea. If you do experience any of these conditions, you should consult your physician before continuing with your exercise program.
3. Keep children and pets away from the equipment. The equipment is designed for adult use only.
4. Use the equipment on a solid, flat level surface with a protective cover for your floor or carpet. To ensure safety, the equipment should have at least 8 feet (240CM) of free space behind it and 2 feet (60 CM) on each side. Do not place the treadmill on any surface that blocks air openings. To protect the floor or carpet from damage, place a mat under the treadmill.
5. Ensure that all nuts and bolts are securely tightened before using the equipment. The safety of the equipment can only be maintained if it is regularly examined for damage and/or wear and tear.
6. Always use the equipment as indicated. If you find any defective components while assembling or checking the equipment, or if you hear any unusual noises coming from the equipment during exercise, discontinue use of the equipment immediately and do not use until the problem has been rectified.
7. Wear suitable clothing while using the equipment. Avoid wearing loose clothing that may become entangled in the equipment.
8. Do not place fingers or objects into the moving parts of the equipment.
9. The maximum weight capacity of this unit is 220 pounds (100 KG).
10. The equipment is not suitable for therapeutic use.
11. To avoid bodily injury and/or damage to the product or property, proper lifting and moving is required.
12. Your product is intended for use in cool, dry conditions. You should avoid storage in extreme cold, hot or damp areas as this may lead to corrosion and other related problems.
13. This equipment is designed for indoor and home use only, it is not intended for commercial use!

# **IMPORTANT OPERATING INSTRUCTIONS**

1. Insert the power plug directly into the socket.
2. Read the manual before operating the equipment.
3. Changes in speed do not occur immediately. Set your desired speed using the adjustment keys on the remote control. The speed will increase gradually.
4. While on the treadmill, move with caution as distractions may cause you to lose balance and stray from walking in the center of the belt. This may result in serious injury.
5. This unit starts at a very low speed. To begin use, stand on the side rails while it starts up, then step onto the belt once it's in motion.
6. A safety key is provided for emergency use. The treadmill will function only if the safety key is inserted into the console. In case of emergency, remove the safety key to immediately stop the belt and shut off the treadmill. The display screen will reset once the safety key is reinserted.
7. This equipment is designed for adult use only! Children should not be allowed to use or play near this equipment. When present, children should always be supervised by an adult.
8. Women who are pregnant or nursing should consult a physician before attempting to begin any exercise program.
9. Always stay hydrated during and after exercise.
10. Do not lift the treadmill.
11. The treadmill will automatically stop after about 5 seconds if user is not standing on it.



## **IMPORTANT NOTE:**

**The belt must be lubricated before the first use! Please see *Page 9* for instructions on how to properly apply lubricant.**

# EXPLODED DIAGRAM

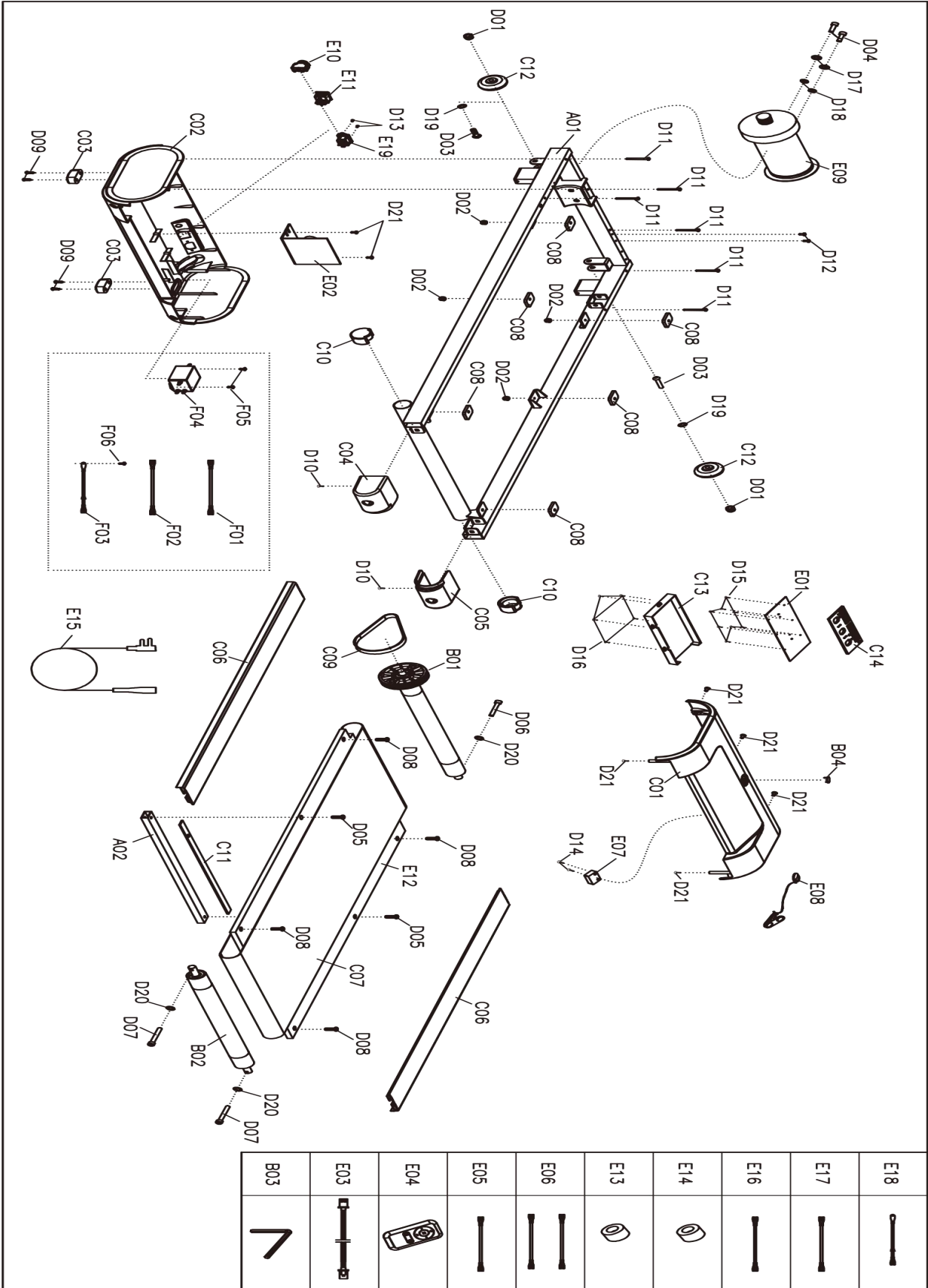

# PARTS LIST

No.	Description	Spec.	Qty.	No.	Description	Spec.	Qty.
A01	Main Frame		1	D15	Screw	ST2.5*6.0	8
A02	Running Board Strengthen Tube		1	D16	Screw	ST2.9*6	5
B01	Front Roller		1	D17	Spring Washer	M8	2
B02	Rear Roller		1	D18	Flat Washer	M8	2
B03	Allen Wrench	5mm	1	D19	Washer	M8	2
B04	Safety Key Plate		1	D20	Washer	M6	3
C01	Motor Top Cover		1	D21	Screw	ST4.2*12	5
C02	Motor Bottom Cover		1	D22	Screw	ST4.2*12	2
C03	Foot Pad		2	D23	Bolt	M6*25	2
C04	Left End Cap		1	E01	Console		1
C05	Right End Cap		1	E02	Control Board		1
C06	Side Rail		2	E03	Console Communication Wire		1
C07	Running Belt		1	E04	Remote Control		1
C08	Rubber Cushion		6	E05	AC Single Line	Blue	1
C09	Motor Belt		1	E06	AC Single Line	Brown	2
C10	C Shape Foot Pad		2	E07	Speed Sensor		1
C11	Rubber Strip		1	E08	Safety Key		1
C12	Adjustable Wheel		2	E09	DC motor		1
C13	Console Board Cover		1	E10	Overload Protector		1
C14	Optical Grating		1	E11	Square Switch		1
D01	Nut	M8	2	E12	Running Board		1
D02	Nut	M6	4	E13	Magnetic Ring		1
D03	Bolt	M8*40	2	E14	Magnetic Core		1
D04	Bolt	M8*15	2	E15	Power Wire		1
D05	Bolt	M6*46	2	E16	AC Single Line	Brown	1
D06	Bolt	M6*45	1	E17	AC Single Line	Blue	1
D07	Bolt	M6*55	2	E18	Grounding Wire		1
D08	Bolt	M6*28	2	E19	Power Socket		1
D09	Bolt	M5*16	4	F01	AC Single Line	Brown	1
D10	Bolt	M5*12	2	F02	AC Single Line	Blue	1
D11	Screw	ST4.2*50	6	F03	Grounding Wire	Green and Yellow	1
D12	Screw	ST4.2*12	2	F04	Filter		1
D13	Screw	ST2.9*8.0	2	F05	Screw	ST4.2*12	2
D14	Screw	ST2.9*8.0	2	F06	Screw	ST4.2*12	1

## CARTON CONTENTS:

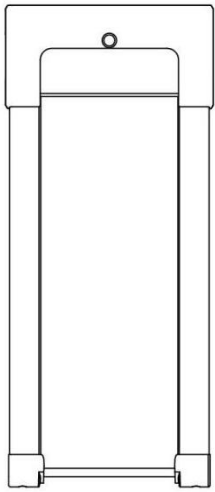

A



B

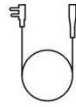

C



D



E



F

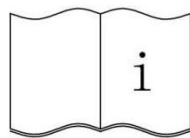

G

No.	Description	Specification	Qty.
A	Walking Treadmill		1
B	Remote Control		1
C	Power Wire		1
D	Safety Key		1
E	Wrench		1
F	Lubricant	20ml/bottle	1
G	Manual		1

### Ordering Replacement Parts (U.S. and Canadian Customers only)

Please provide the following information in order for us to accurately identify the part(s) needed:

- ✓ The model number (found on cover of manual)
- ✓ The product name (found on cover of manual)
- ✓ The part number found on the “EXPLODED DIAGRAM” and “PARTS LIST” (found near the front of the manual)

Please contact us at [support@sunnyhealthfitness.com](mailto:support@sunnyhealthfitness.com) or 1- 877 - 90SUNNY (877-907-8669).

# USER INSTRUCTIONS

STEP 1:

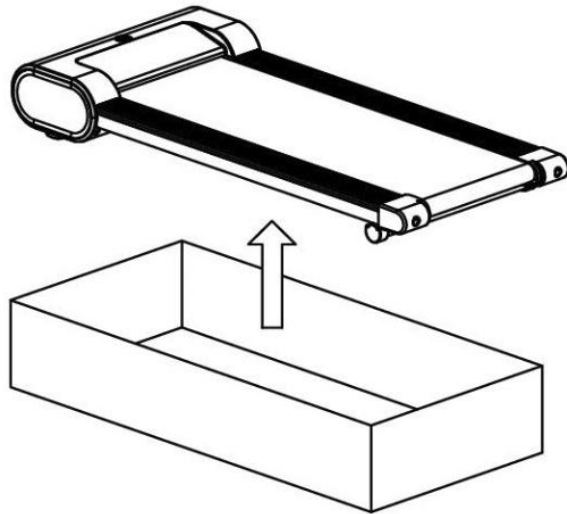

STEP 2:

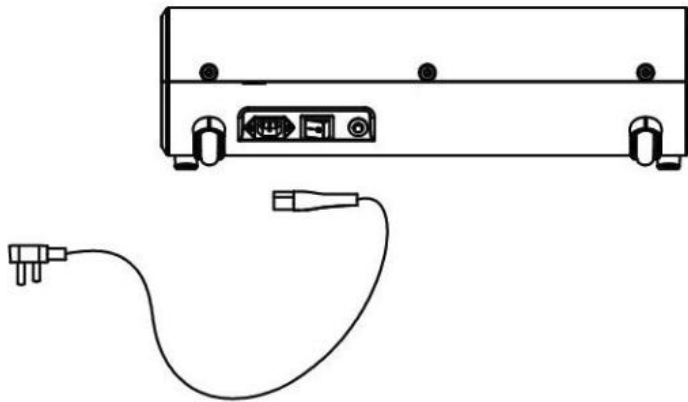

STEP 3:

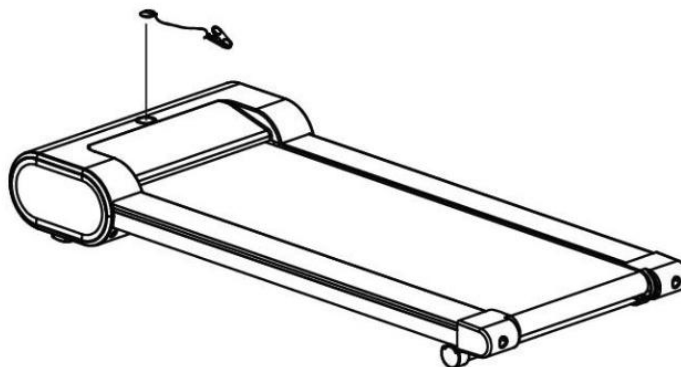



# MAINTENANCE & CARE

General cleaning will help prolong the life and performance of your treadmill. Keep the unit clean and maintained by dusting the components on a regular basis. Clean both sides of the running belt to prevent dust from accumulating underneath the belt. Keep your running shoes clean so that dirt from your shoes does not wear out the **Running Board (No. E12)** and **Running Belt (No. C07)**. Clean the surface of the **Running Belt (No. C07)** with a clean damp cloth.

To better maintain the treadmill and prolong its life, it is suggested that the treadmill be powered off for 10 minutes every 2 hours and fully powered off whenever not in use.

## **CENTERING THE RUNNING BELT:**

Place the treadmill on level ground and set it at 2mph to check if the **Running Belt (No. C07)** drifts.

1. If the **Running Belt (No. C07)** moves to the right, turn the right adjusting bolt  $\frac{1}{4}$  turn *clockwise*, then turn the left adjustment bolt  $\frac{1}{4}$  turn *counter-clockwise*. If the belt does not move, repeat this step until it centers. Refer to Figure A.

A

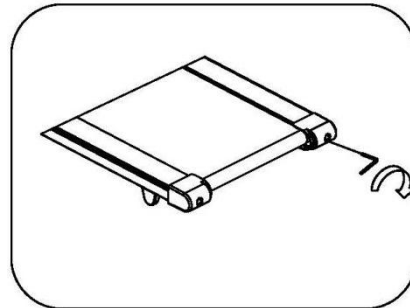

2. If the **Running Belt (No. C07)** moves to the left, turn the left adjusting bolts  $\frac{1}{4}$  of a turn *clockwise*, then turn the right adjustment bolt  $\frac{1}{4}$  turn *counter-clockwise*. If the belt does not move, repeat this step until it centers. Refer to Figure B.

B

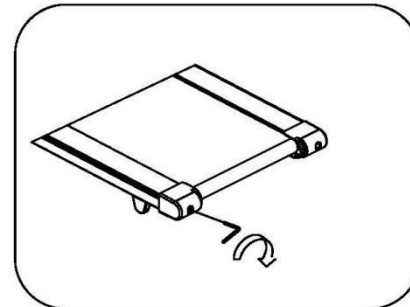

3. Over time the **Running Belt (No. C07)** will loosen. To tighten the belt, turn the **Left & Right** sides adjustment bolts one full turn *clockwise*, check the tension of the belt. Continue this process until belt is at the correct tension. Make sure to adjust both sides equally to ensure correct belt alignment. Refer to diagram "C"

C

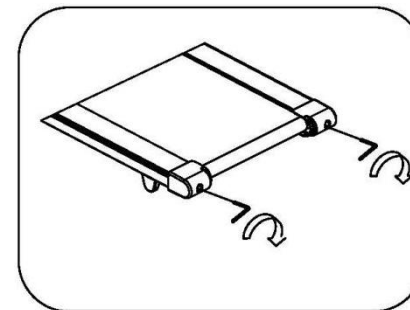

# LUBRICATING THE TREADMILL

## **IMPORTANT NOTE:**

You will need to lubricate your treadmill before the first use.

## **RUNNING BELTS & TREADMILL LUBRICANT:**

Lubricating the **Running Board (No. E12)** and **Running Belt (No. C07)** is essential as the friction between the two affects the life span and function of the treadmill. Therefore, it is suggested that the **Running Board (No. E12)** and **Running Belt (No. C07)** be inspected regularly. Should you find any wear on the **Running Board (No. E12)**, please contact us at: [support@sunnyhealthfitness.com](mailto:support@sunnyhealthfitness.com).

**WARNING:** Always unplug the treadmill from the electrical outlet before cleaning, lubricating or repairing the unit.

## **HOW TO LUBRICATE:**

1. Raise the **Running Belt (No. C07)** up on one side and apply lubricant to the **Running Board (No. E12)**. Use a rag to thoroughly wipe the lubricant over the running deck. Repeat this process for the other side.
2. The moving parts should turn freely and quietly. Abnormality of moving parts will affect the safety of the equipment. Inspect and tighten bolts regularly.
3. To better maintain the treadmill and prolong its lifespan, it is suggested that maintenance be done on a regular basis.
4. **DO NOT LOOSEN OR MAKE ANY ADJUSTMENTS TO THE RUNNING BELT WHILE APPLYING LUBRICANT.** A loose **Running Belt (No. C07)** will result in the runner sliding off during use, while too tight of a **Running Belt (No. C07)** will negatively affect the motor's performance and create more friction between the roller and **Running Belt (No. C07)**. The most suitable tightness for the **Running Belt (No. C07)** is when it is pulled out **50-75mm** from the **Running Board (No. E12)**.

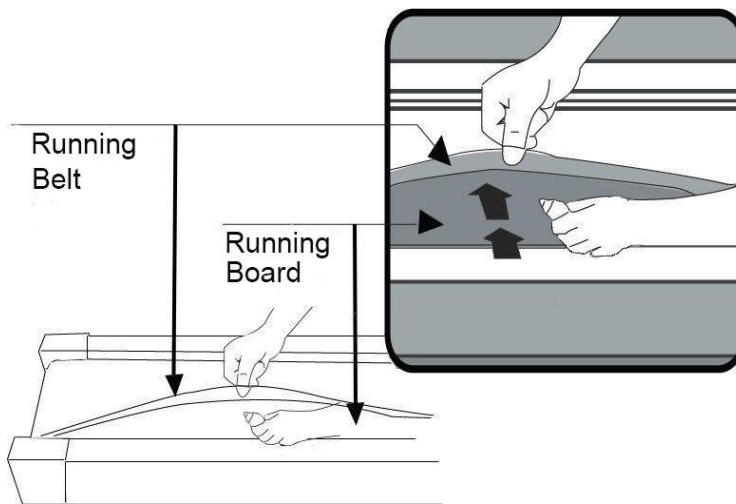

## **The following time table is recommended:**

Light user (less than 3 hours/ week)	<i>every six months</i>
Medium user (3-5 hours/ week)	<i>every three months</i>
Heavy user (more than 5 hours/ week)	<i>every two months</i>

# HOW TO MOVE THE TREADMILL

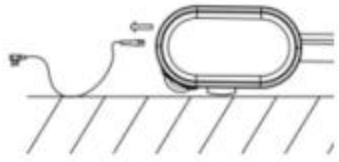

Please remove the power cord from the treadmill before moving.

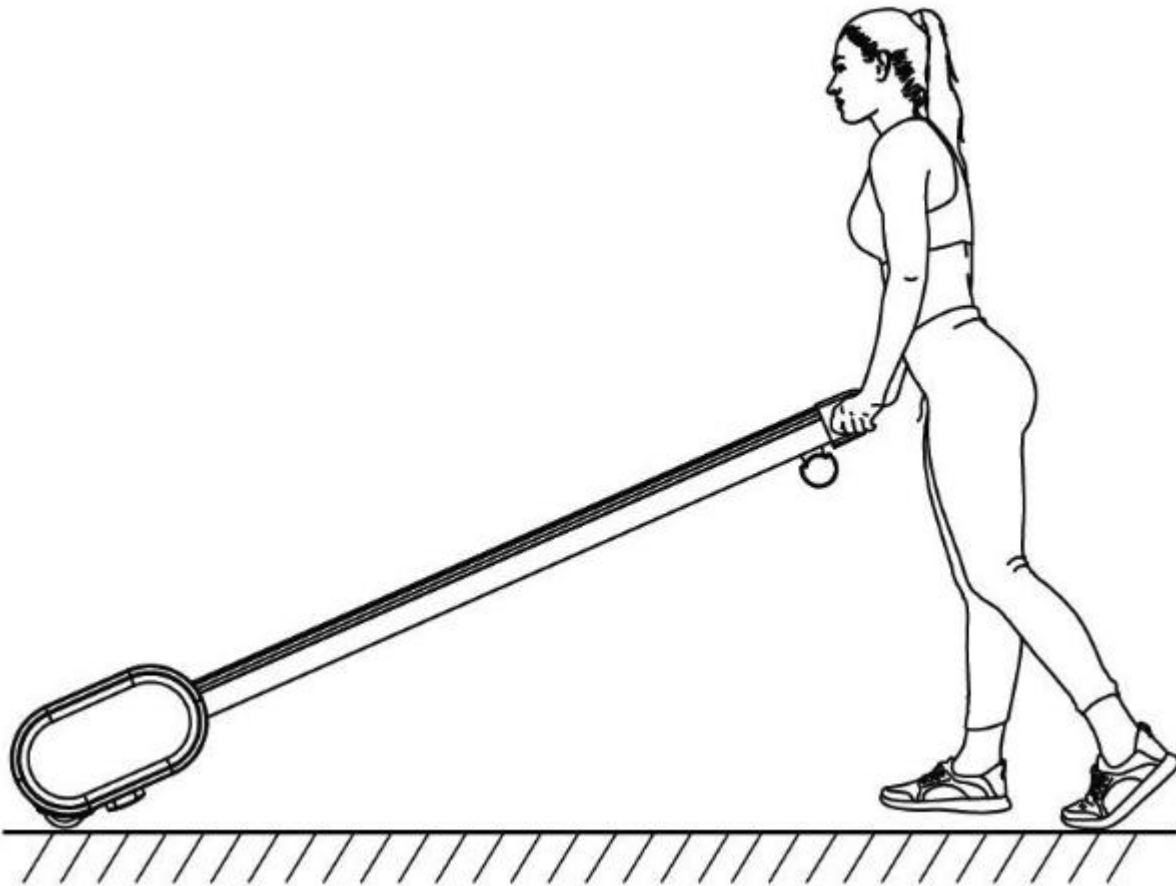
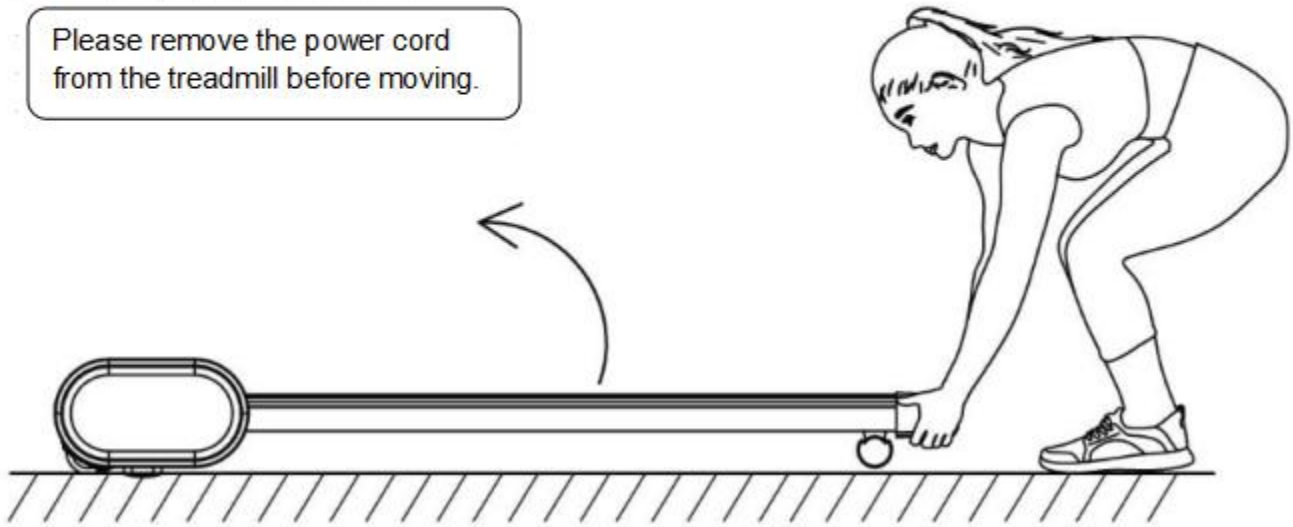

# IMPORTANT ELECTRICAL INFORMATION

**WARNING:** This treadmill requires a power source of **8 amps (100-120V)** in order to properly operate. For your safety, as well as the safety of others, verify that the power source is correct before plugging in the equipment. Any power source above or below this level could cause significant damage to the equipment and/or user.

## **GROUNDING METHODS:**

This product must be grounded. Grounding provides the least resistance for electrical current and will reduce the risk of electric shock. The plug must be plugged into an appropriate outlet that is properly installed and grounded in accordance with all local codes and ordinances. Ensure that the product is connected to an outlet which contains the same configuration as the plug. Do not use an adaptor for this product.

This product is for use on a nominal 100-120V circuit and has a grounding plug that looks like the plug illustrated in sketch A. Make sure that the product is connected to an outlet having the same configuration as the plug. No adaptor should be used with this product.

## **DANGER:**

Improper connection of the equipment-grounding conductor can result in risk of electrical shock. Check with a certified electrician if you are in doubt as to whether the product is properly grounded. Do not modify the plug provided with the product. If it will not fit the outlet, have a proper outlet installed by an electrician.

## **WARNING!**

1. NEVER use a ground fault circuit interrupt (GFCI) wall outlet with this treadmill. Route the power cord away from any moving part of the treadmill including the elevation mechanism and transportation wheels.
2. NEVER operate the treadmill using a generator or UPS power supply.
3. NEVER remove any cover without first disconnecting AC power.
4. NEVER expose the treadmill to rain or moisture. This treadmill is not designed for use outdoors, near pools, or in any other high humidity environment.

### **GROUNDING METHOD**

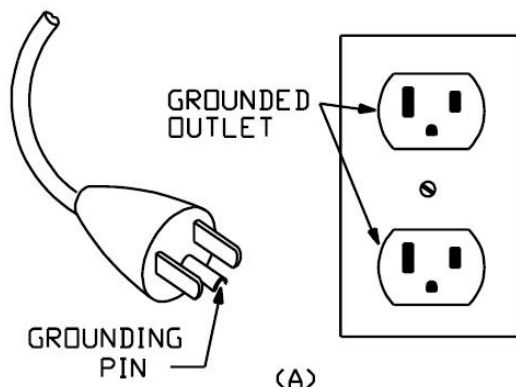

# **BATTERY INSTALLATION & REPLACEMENT**

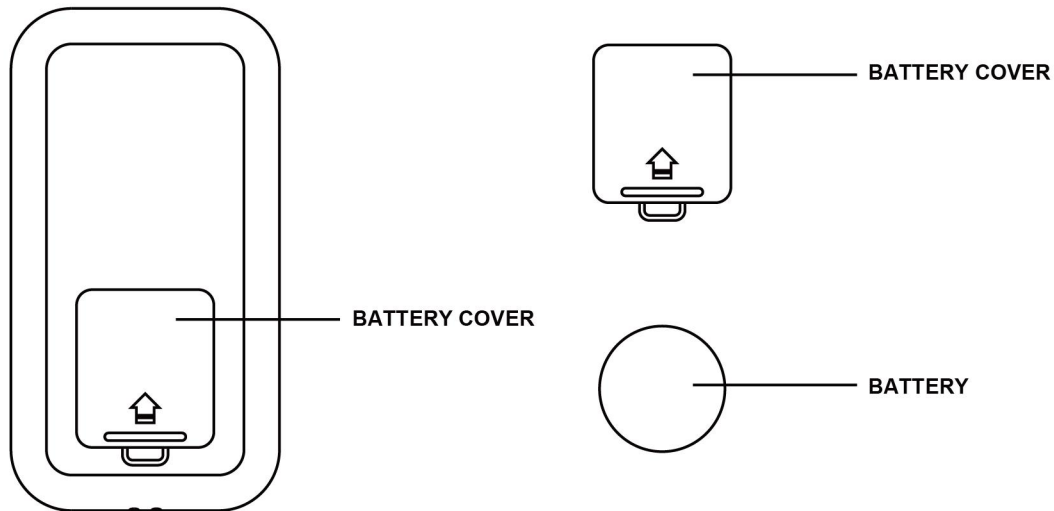

## **BATTERY INSTALLATION:**

1. Remove the battery cover.
2. Take out the 1pc CR2032 battery that is included inside the remote control box.
3. Install the battery into the battery holder with the positive end facing up.
4. Put the battery cover back on to the battery holder.

## **BATTERY REPLACEMENT:**

1. Remove the battery cover.
2. Remove the old battery and install the new battery into the battery holder with the positive pole facing up.
3. Put the battery cover back on to the battery holder.

Dispose the old battery according to your regional guidelines.

# THE DISPLAY CONSOLE



TIME 3:35    SPD 3.0    MILE 0.88    KCAL 20.8    STEP 00035

## **WINDOW DISPLAY:**

Displays time, distance, calories, steps and speed value in turn every 5 seconds.

## **REMOTE CONTROL FUNCTIONS:**

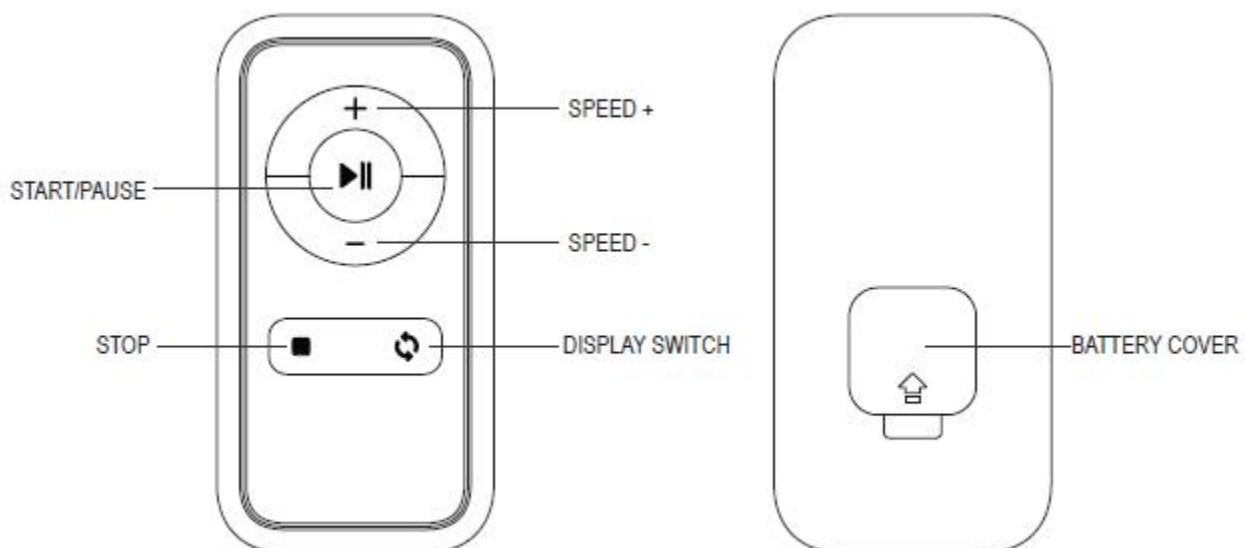

**Note: If the treadmill does not respond to the remote control, you will need to resync the treadmill and remote control. To sync the remote control with the treadmill, press the start/pause button on the remote control for five seconds.**

1. **START/PAUSE BUTTON:** Press the START button, so that treadmill begins running. 0.5 MPH (Miles per hour) is the default start speed. During exercise, you also can press this button to pause the machine.
2. **SPEED +/- BUTTONS:** Press the +/- buttons to increase or decrease the speed in increments of 0.1 MPH (Miles per hour). Pressing and holding either of these buttons for a duration of over ½ a second will increase or decrease the speed continually.
3. **STOP BUTTON:** When in use, press the STOP button to terminate your workout session completely. All data will be deleted and reset to the initial setting.
4. **DISPLAY SWITCH BUTTON:** When in use, you can press this button to switch the display between Time, Distance, Calories, Steps and Speed value.

**\*NOTE: The maximum speed on this treadmill is 3.7 MPH (Miles per hour).**

PROGRAMS	Initial	Default Value	Set Range	Display Range
TIME (MIN: SECOND)	0	-	-	0: 00—99:59
SPEED(MPH)	0.0	0.5	0.5-3.7	0.5—3.7
DISTANCE(MILES)	0	-	-	0.0--99.9
STEP	0	-	-	0-99999
CALORIE(KCAL)	0	-	-	0--9999

### LUBRICATION REMINDER:

Your treadmill needs lubrication maintenance every 188 miles. The system will release a beeping sound every 10 seconds and display an “OIL” icon on your display to remind you when it’s time. Please read the LUBRICATING THE TREADMILL instructions on Page 9 to learn the proper steps to lubricate your treadmill. Apply the lubricant to the middle of the running deck on both sides. After application, press and hold the STOP button for 3 seconds to clear the reminder.

### POWER SAVE FUNCTION:

When the treadmill has been idle for 10 minutes, it will enter Power Saving Mode. While the treadmill is in this mode, the window display of the console will be turned off. To turn it back on, press any button.

### POWER ON:

Flick the power switch to this symbol to turn on the treadmill.

### POWER OFF:

Flick the power switch to this symbol to turn the treadmill off at any time. This includes during exercise.

# EXERCISE INSTRUCTIONS

## **GETTING STARTED:**

Before starting any exercise program, you should consult your physician to determine if you have any medical or physical conditions that could put your health and safety at risk or prevent you from using the equipment properly.

Be aware of your body's signals. Incorrect or excessive exercise can damage your health.

Stop exercising immediately if you experience any of the following symptoms: pain, tightness in your chest, irregular heartbeat, shortness of breath, lightheadedness, dizziness, or feelings of nausea.

Get to know your treadmill. Before attempting to use the treadmill take some time to stand alongside and familiarize yourself with the controls.

1. Before beginning exercise, stand on side rails.
2. Next, attach the clip end of the **Safety Key (No. E08)** to your clothes and insert the magnetic end of the key to the console.
3. Press the START button to start the machine.
4. The machine will start at the system default setting speed of **0.5 MPH**. When you feel comfortable, you may slowly increase the speed.
5. When you are finished with your exercise, press the STOP button or you can remove the magnetic end of the **Safety Key (No. E08)** to stop the machine.



# TROUBLESHOOTING

PROBLEM	POSSIBLE CAUSE	SUGGESTED ACTION
Treadmill will not start	Not plugged in.	Plug cord into outlet
	Safety Key not inserted.	Insert Safety Key
Running belt not centered	Running belt tension not correct on the left or right sides of the running board.	Tighten the adjustment bolts on the left and right side of the rear roller.
Console not working	Wires from the console and bottom control board are not properly connected.	Check wire connections from the console to the control board.
	Transformer is damaged.	If the transformer is damaged, contact customer service.
0001 ERROR: Message failure	Wires from the console and bottom control board are not properly connected.	Check wire connections from the console to the control board. If the wire has been punctured or damaged, you will need to replace it. If the problem is not rectified, you may need to replace the control board.
0002 ERROR: Burst clash protection	Incoming voltage is lower than 50% of the required voltage.	Check that the incoming power supply is the correct voltage.
0005 ERROR: Current overload protection (Self Protecting System)	The incoming voltage is too low or too high. The control board is damaged.	Restart the treadmill. Check the incoming voltage to ensure its correct. Check the control board, replace if damaged.
	A moving part of the treadmill is stuck and therefore the motor is unable to rotate properly.	Inspect moving parts of the treadmill to ensure that they are operating correctly. Check the motor, listen for any strange noises and check for a burning smell. Replace the motor if necessary.

0006 ERROR: Motor abnormality	The motor wire is not connected, or the motor is damaged.	Check motor wires to see if the motor is connected. If the wire has been punctured or damaged, you will need to replace it. If the problem is not rectified, you may need to replace the motor.
0008 ERROR: Control board abnormality	The control board is not connected.	Check the upper and middle wires to see if the control board is connected. If the wire has been punctured or damaged, you will need to replace it. If the problem is not rectified, you may need to replace the control board.
0009 ERROR: Inversion error	The treadmill sets upright or not placed horizontally.	Adjust the treadmill and place it horizontally. If the wires of the control board do not connect well, replace to a new control board.
0010 ERROR: Motor abnormality	The motor is damaged, or a moving part of the treadmill is stuck and therefore the motor is unable to rotate properly.	Inspect moving parts of the treadmill to ensure that they are operating correctly. Replace the motor if necessary.

**NOTE: If you are unable to resolve an issue using the troubleshooting guide above, please contact Customer Service at [support@sunnyhealthfitness.com](mailto:support@sunnyhealthfitness.com)**

# CONNECT WITH US

FOR FITNESS  
ARTICLES, VIDEOS  
& WORKOUTS



@SUNNYHEALTHANDFITNESS



@SUNNYHEALTHFITNESS



@SUNNYHEALTHFIT



/SUNNYHEALTHFITNESS



/SUNNYHEALTHANDFITNESS

WWW.SUNNYHEALTHFITNESS.COM