



PREMIUM SMART TREADMILL

WITH AUTO INCLINE

SF-T7515 SMART

USER MANUAL



IMPORTANT! Please retain owner's manual for maintenance and adjustment instructions. Your satisfaction is very important to us, **PLEASE DO NOT RETURN UNTIL YOU HAVE CONTACTED US:** support@sunnyhealthfitness.com or 1-877-90SUNNY (877-907-8669).



WWW.SUNNYHEALTHFITNESS.COM

IMPORTANT SAFETY INFORMATION

We thank you for choosing our product. To ensure your safety and health, please use this equipment correctly. It is important to read this entire manual before assembling and using the equipment. Safe and effective use can only be achieved if the equipment is assembled, maintained, and used properly. It is your responsibility to ensure that all users of the equipment are informed of all warnings and precautions.

1. Before starting any exercise program, you should consult your physician to determine if you have any medical or physical conditions that could put your health and safety at risk or prevent you from using the equipment properly. Your physician's advice is essential if you are taking medication that affects your heart rate, blood pressure, or cholesterol level.
2. Be aware of your body's signals. Incorrect or excessive exercise can damage your health. Stop exercising if you experience any of the following symptoms: pain, tightness in your chest, irregular heartbeat, shortness of breath, lightheadedness, dizziness, or feelings of nausea. If you do experience any of these conditions, you should consult your physician before continuing with your exercise program.
3. Keep children and pets away from the equipment. The equipment is designed for adult use only.
4. Use the equipment on a solid, flat level surface with a protective cover for your floor or carpet. To ensure safety, the equipment should have at least 8 feet (240 CM) of free space behind it and 2 feet (60 CM) on each side. Do not place the treadmill on any surface that blocks air openings. To protect the floor or carpet from damage, place a mat under the treadmill.
5. Ensure that all nuts and bolts are securely tightened before using the equipment. The safety of the equipment can only be maintained if it is regularly examined for damage and/or wear and tear.
6. Always use the equipment as indicated. If you find any defective components while assembling or checking the equipment, or if you hear any unusual noises coming from the equipment during exercise, discontinue use of the equipment immediately and do not use until the problem has been rectified.
7. Wear suitable clothing while using the equipment. Avoid wearing loose clothing that may become entangled in the equipment.
8. Do not place fingers or objects into the moving parts of the equipment.
9. The maximum weight capacity of this unit is 240 lbs (110 kgs).
10. The equipment is not suitable for therapeutic use.
11. To avoid bodily injury and/or damage to the product or property, proper lifting and moving are required.
12. Your product is intended for use in cool and dry conditions. You should avoid storage in extreme cold, hot or damp areas as this may lead to corrosion and other related problems.
13. This equipment is designed for indoor and home use only; it is not intended for commercial use.

▲ IMPORTANT NOTE:

The running belt must be lubricated before the first use! Please see Page 6 for instructions on how to properly apply lubricant.

ASSEMBLY CONTENTS

WHEN YOU OPEN THE CARTON, YOU WILL FIND THE FOLLOWING PARTS:

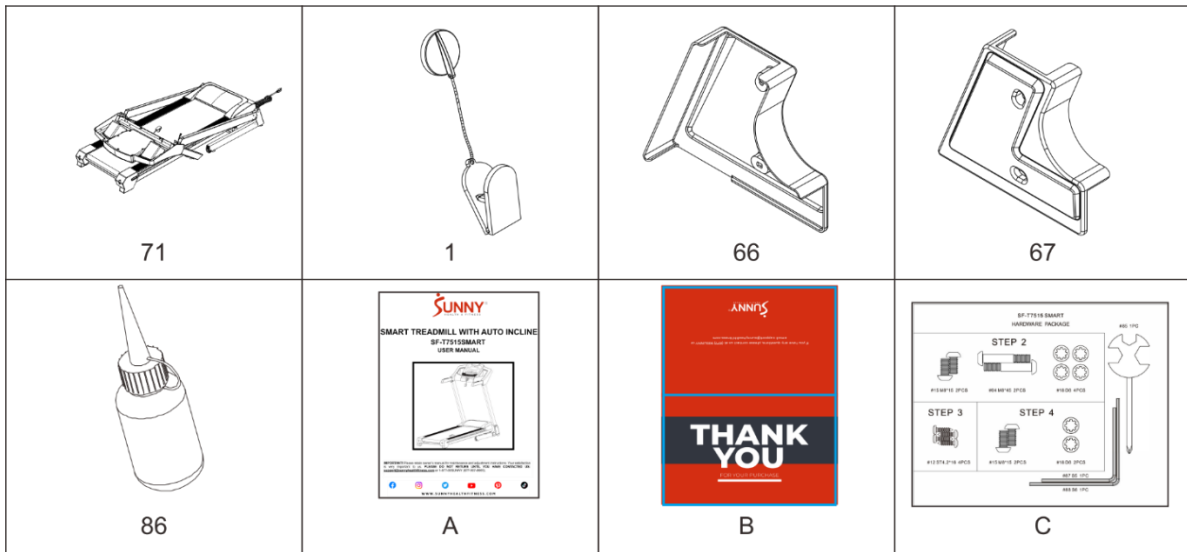

No.	Description	Spec.	Qty.
71	Main Frame		1
1	Safety Key		1
66	Right Side Cover	225*183*52	1
67	Left Side Cover	225*183*52	1
86	Silicone Oil		1
A	Manual		1
B	Thank You Card		1
C	Hardware package		1

HARDWARE PACKAGE

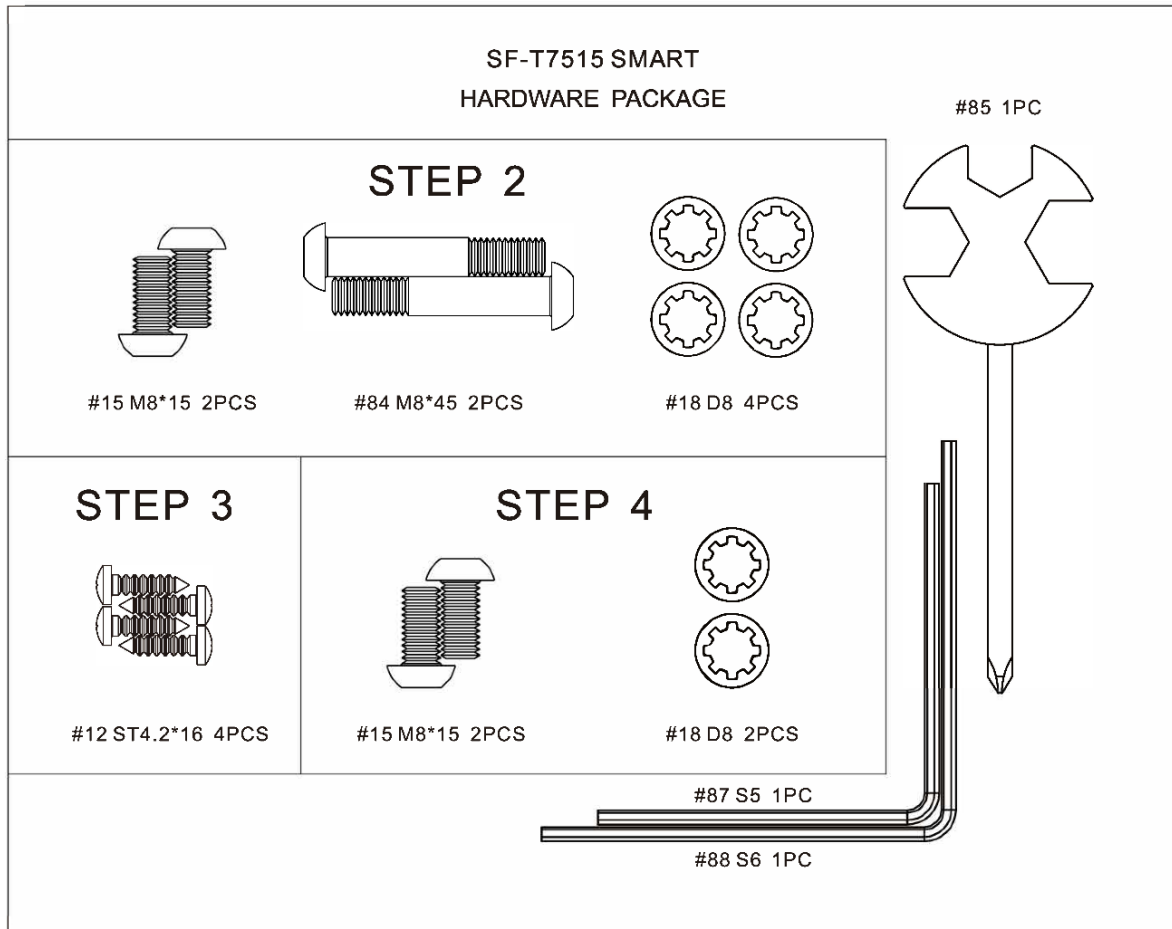

Ordering Replacement Parts (U.S. and Canadian Customers only)

Please provide the following information in order for us to accurately identify the part(s) needed:

- ✓ The model number (found on cover of manual)
- ✓ The product name (found on cover of manual)
- ✓ The part number found on the “EXPLODED DIAGRAM” and “PARTS LIST” (found near the end of the manual)

Please contact us at support@sunnyhealthfitness.com or 1-877-90SUNNY (877-907-8669).

ASSEMBLY INSTRUCTIONS

We value your experience using Sunny Health and Fitness products. For assistance with parts or troubleshooting, please contact us at support@sunnyhealthfitness.com or 1-877-90SUNNY (877-907-8669).

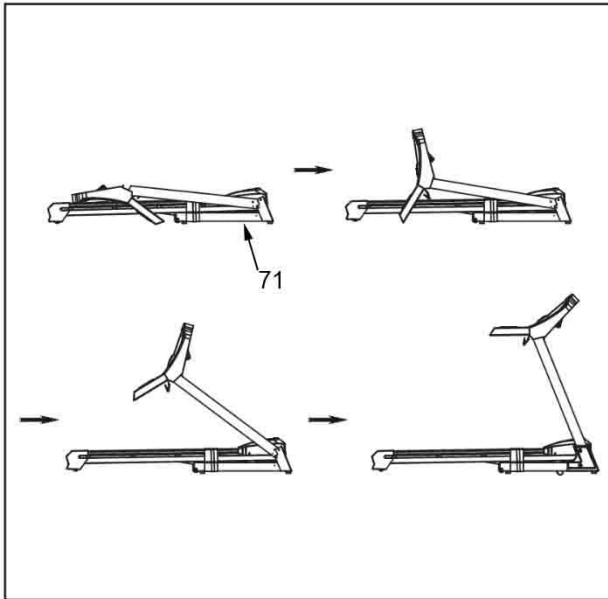

STEP 1:

Open the carton and take out all the contents. Place the **Main Frame (No. 71)** on level ground and ensure that you have a clean, adequate workspace. Follow the diagram on the left to lift the top console upright.

NOTE: Be careful not to puncture the wires when unfolding! Do not remove the packing belt now.

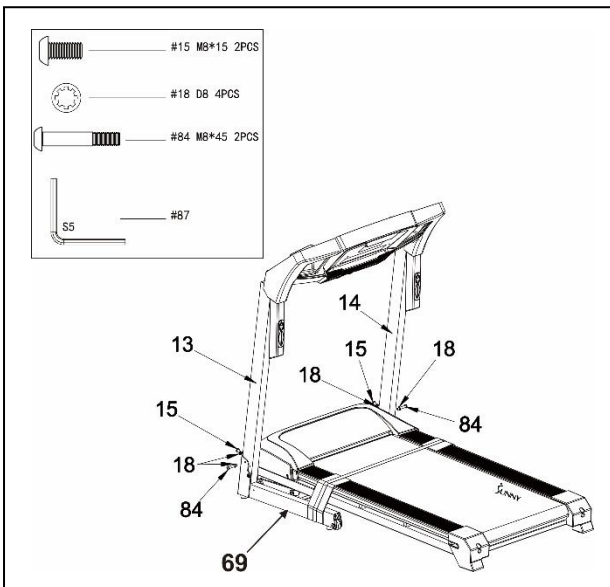

STEP 2:

Secure the **Left & Right Support Tubes (No. 13 & No. 14)** to the **Base Frame (No. 69)** using 2 **Half-roundhead Hex Bolts (No. 15)**, 2 **Half-roundhead Hex Bolts (No. 84)**, and 4 **Serrated Gaskets (No. 18)**. Tighten and secure with **Allen Wrench (No. 87)**.

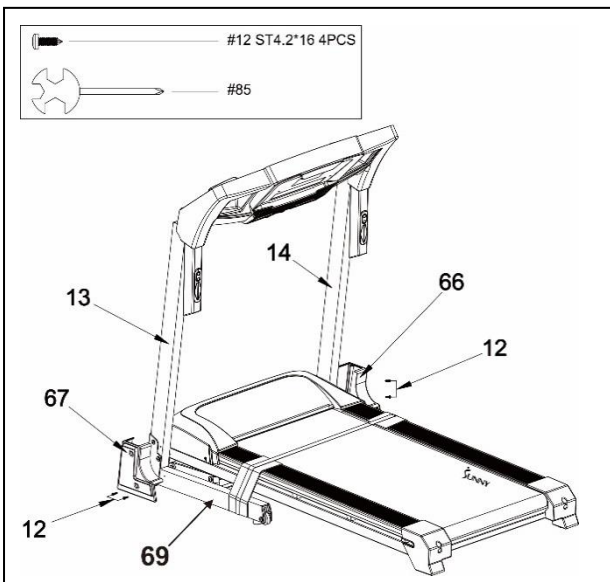

STEP 3:

Attach the **Left & Right Side Covers (No. 67 & No. 66)** to the **Base Frame (No. 69)** of the **Left & Right Support Tubes (No. 13 & No. 14)** using 4 **Cross Recessed Pan Head Tapping Screws (No. 12)**. Tighten and secure with **Spanner with Screwdriver (No. 85)**.

We value your experience using Sunny Health and Fitness products. For assistance with parts or troubleshooting, please contact us at support@sunnyhealthfitness.com or 1-877-90SUNNY (877-907-8669).

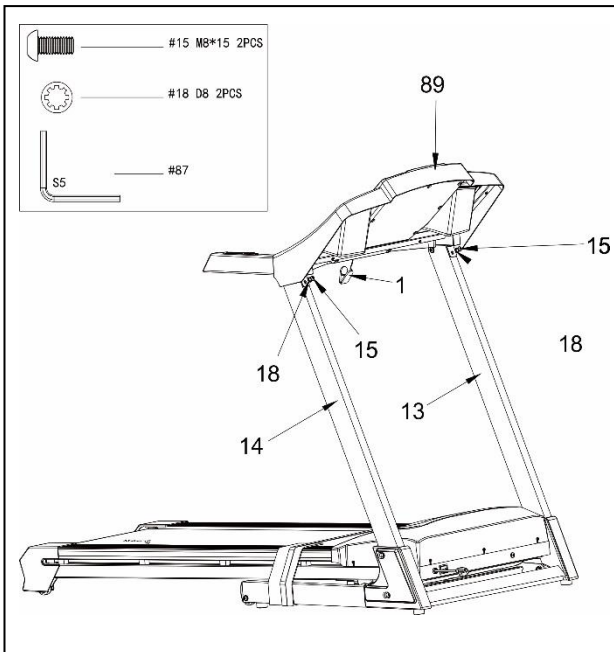

STEP 4:

Secure the **Top Console (No. 89)** to **Left & Right Support Tubes (No. 13 & No. 14)** using **2 Half-roundhead Hex Bolts (No. 15)** and **2 Serrated Gaskets (No. 18)**. Tighten and secure with **Allen Wrench (No. 87)**. Next, insert the **Safety Key (No. 1)** into the **Top Console (No. 89)**.

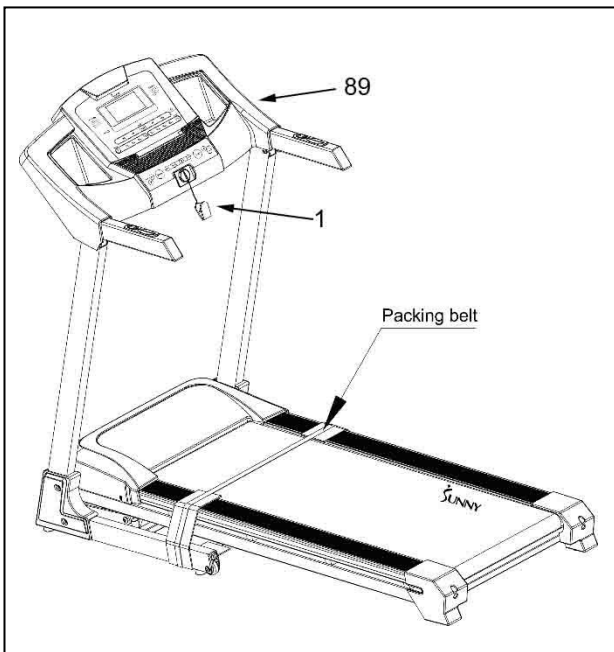

STEP 5:

You may now remove the packing belt. Next, insert the **Safety Key (No. 1)** into the **Top Console (No. 89)**.

IMPORTANT NOTE: The running belt must be lubricated before the first use! Please see Page 6 for instructions on how to properly apply lubricant.

The assembly is complete!

LUBRICATING THE TREADMILL

IMPORTANT NOTE:

You will need to lubricate your treadmill before the first use!

RUNNING BELTS & TREADMILL LUBRICANT:

Lubricating the **Running Belt (No. 50)** and **Running Board (No. 49)** is essential as the friction affects the life span and operations of the treadmill. Inspect the **Running Belt (No. 50)** regularly. If you find any wear on the **Running Board (No. 49)**, please contact us at support@sunnyhealthfitness.com.

▲ WARNING: Always unplug the treadmill from the electrical outlet before cleaning, lubricating, or repairing the unit.

HOW TO LUBRICATE:

Raise the **Running Belt (No. 50)** up on one side and apply lubricant to the **Running Board (No. 49)**. Use a rag to thoroughly wipe the lubricant over the **Running Board (No. 49)**. Repeat this process for the other side.

The following timetable is recommended:

Light user (less than 3 hours/ week)	<i>every 2 months</i>
Medium user (3-5 hours/ week)	<i>every 45 days</i>
Heavy user (more than 5 hours/ week)	<i>every month</i>

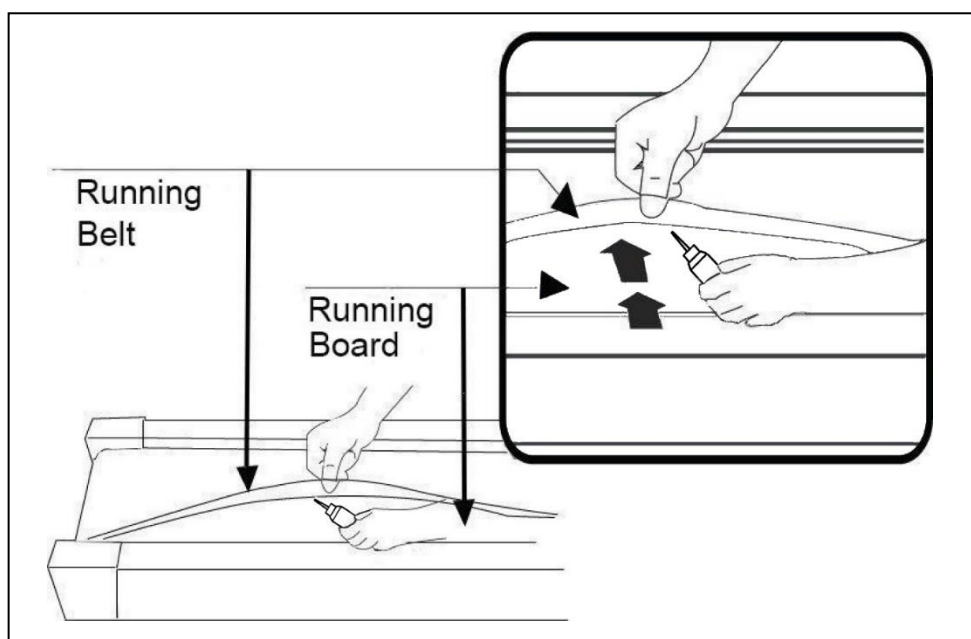

NOTE:

To better maintain the treadmill and prolong its life, it is suggested that the treadmill be powered off for 10 minutes every 2 hours and fully powered off whenever not in use.

DO NOT LOOSEN OR MAKE ANY ADJUSTMENTS TO THE RUNNING BELT WHILE APPLYING LUBRICANT. A loose **Running Belt (No. 50)** will result in the runner sliding off when in use, while too tight of a **Running Belt (No. 50)** will negatively affect the motor's performance and create more friction between the roller and **Running Belt (No. 50)**. The most suitable tightness for the **Running Belt (No. 50)** is when it is pulled out 50-75 mm from the **Running Board (No. 49)**.

MAINTENANCE GUIDE

General cleaning will help to prolong the life and improve the performance of your treadmill. Keep the unit clean and maintained by dusting the components on a regular basis. Cleaning the two exposed sides of the **Running Belt (No. 50)** will prevent dust from accumulating underneath. Keep your running shoes clean so no dirt will stay on the **Running Board (No. 49)** and **Running Belt (No. 50)**. Clean the surface of the **Running Belt (No. 50)** by using a clean damp cloth. Keep liquids away from electrical parts and **Running Belt (No. 50)**.

ADJUSTING THE RUNNING BELT

Place the treadmill on level ground and set it at 3-5 MPH (5-8 KM/H) to check and see if the **Running Belt (No. 50)** drifts from the center. Adjust the **Running Belt (No. 50)** according to instructions below with **Allen Wrench (No. 88)**

1. If the **Running Belt (No. 50)** drifts to the right, turn the right adjusting bolt $\frac{1}{4}$ turn **clockwise**, then turn the left adjusting bolt $\frac{1}{4}$ turn **counter-clockwise**. If the **Running Belt (No. 50)** does not move, repeat this step until it centers. Refer to image A.

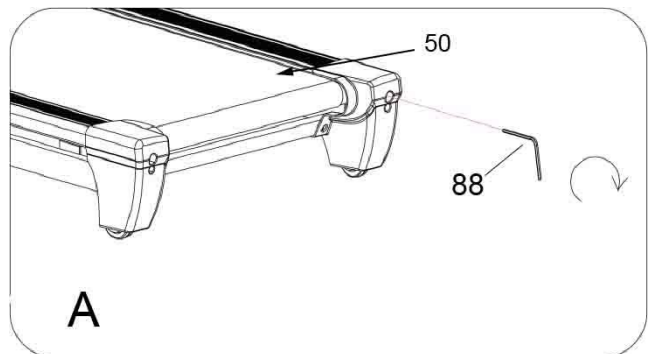

2. If the **Running Belt (No. 50)** drifts to the left, turn the left adjusting bolt $\frac{1}{4}$ turn **clockwise**, then turn the right adjusting bolt $\frac{1}{4}$ turn **counter-clockwise**. If the **Running Belt (No. 50)** does not move, repeat this step until it centers. Refer to image B.

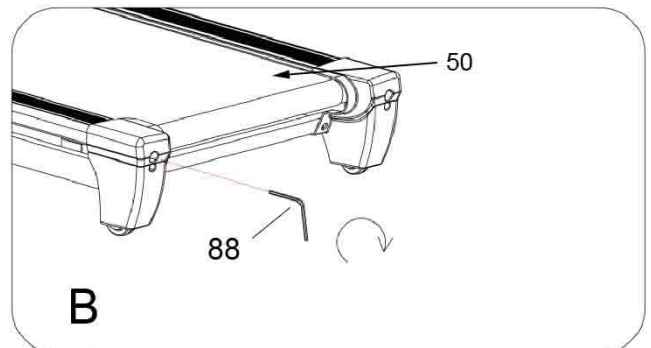

3. Over time, the **Running Belt (No. 50)** will loosen. To tighten the **Running Belt (No. 50)**, turn both the left & right sides adjusting bolts one full turn **clockwise**. Check the tension of the **Running Belt (No. 50)**. Continue this process until **Running Belt (No. 50)** is at the correct tension. Make sure to adjust both sides equally to ensure even alignment. Refer to image C.

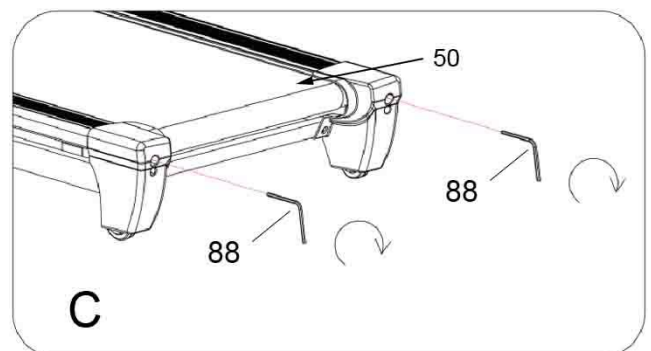

FOLDING INSTRUCTIONS

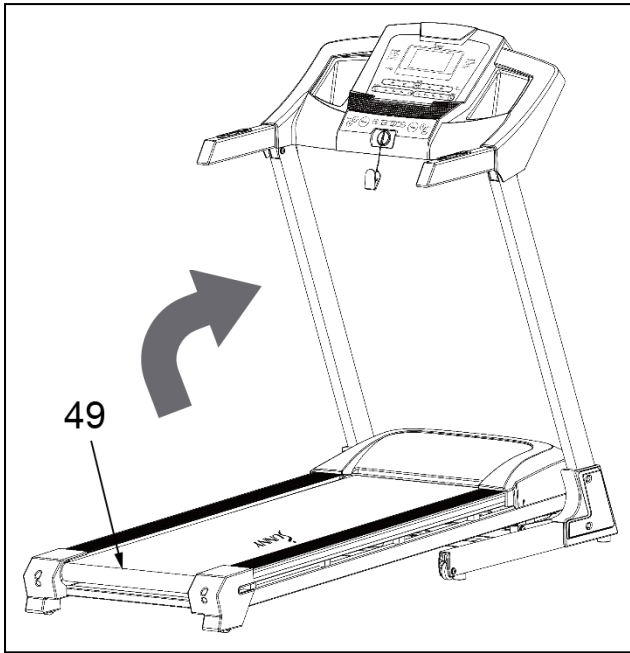

NOTE: Please make sure the incline is at ZERO when folding and unfolding.

FOLDING:

To fold the treadmill, place your hands at the end of the Running Board (**No.49**) and lift the Running Board (**No.49**) all the way up until you hear the safety lock 'Click' from the safety cylinder.

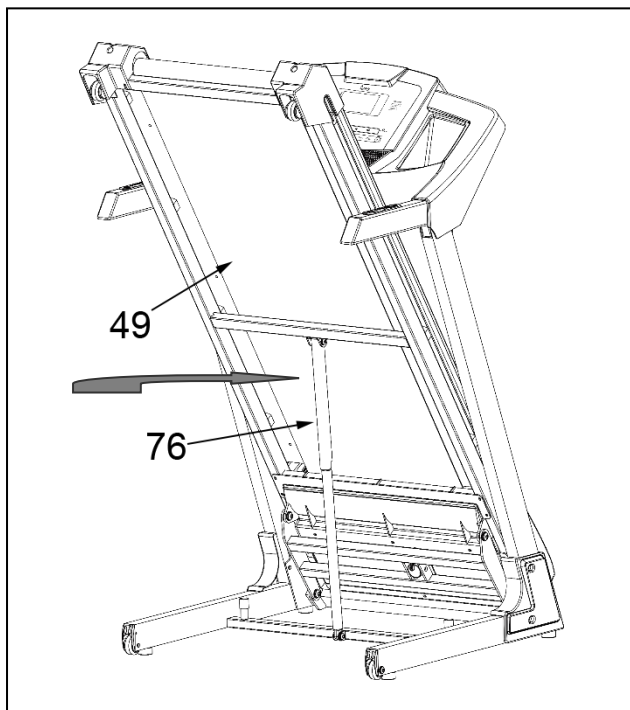



UNFOLDING:

To unfold the treadmill, simply give the **Cylinder (No.76)** a light kick and pull down the Running Board (**No.49**) at the same time. With its soft drop system, the treadmill will unfold slowly.

(Please keep everyone and all pets away from the treadmill when unfolding the treadmill.)

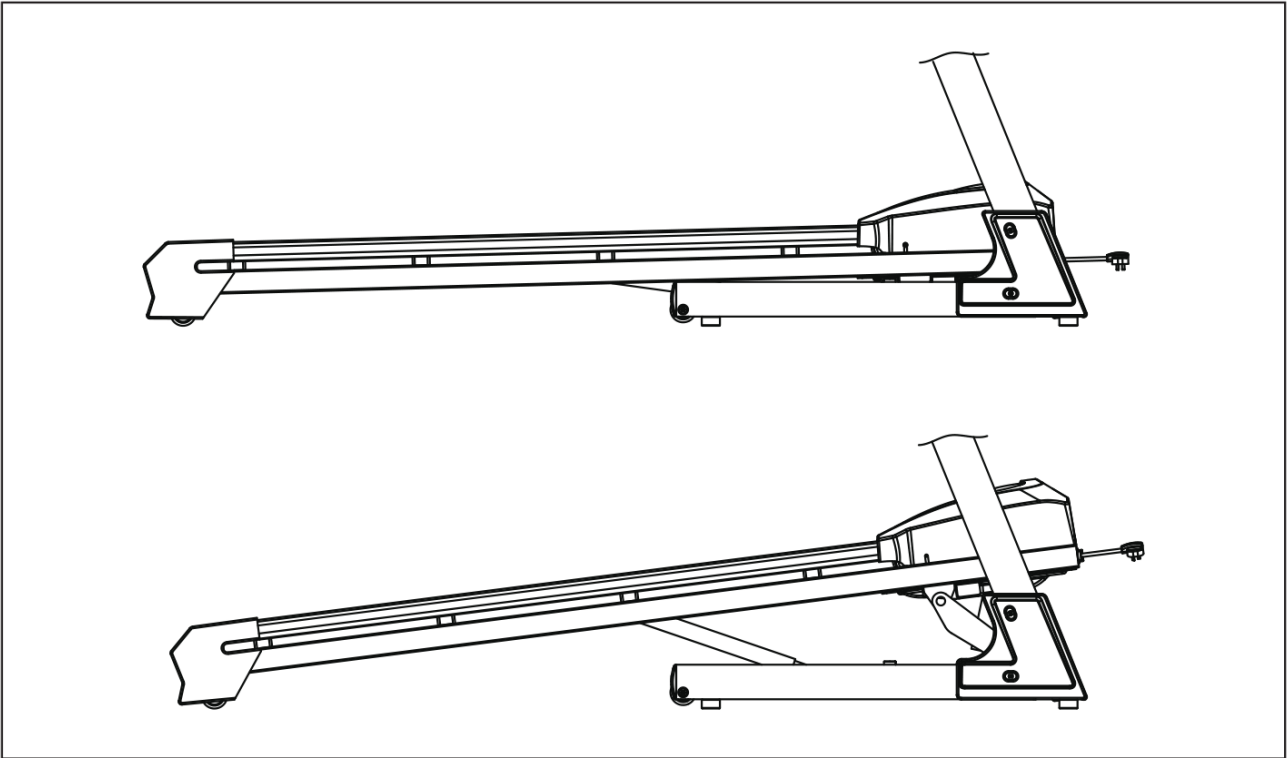
INCLINE INSTRUCTIONS



Console Keys   and **+ - INCLINE Handrail Keys** are used to control the incline level. Increase or decrease the incline level by pressing the incline buttons once per level or holding an incline key down to skip through to the desired level.

INCLINE LEVELS

- (0) = 1.45° (2.5%)
- (1) = 1.7° (3.0%)
- (2) = 2.05° (3.6%)
- (3) = 2.4° (4.2%)
- (4) = 2.75° (4.8%)
- (5) = 3.15° (5.5%)
- (6) = 3.5° (6.1%)
- (7) = 4.0° (7.0%)
- (8) = 4.55° (8.0%)
- (9) = 5.05° (8.8%)
- (10) = 5.65° (9.9%)
- (11) = 6.25° (11.0 %)
- (12) = 6.85° (12.0%)

Quick 3, 6, 9, 12 INCLINE Keys give you the ability to instantly program a specific incline level with the push of a button.

HOW TO MOVE THE TREADMILL

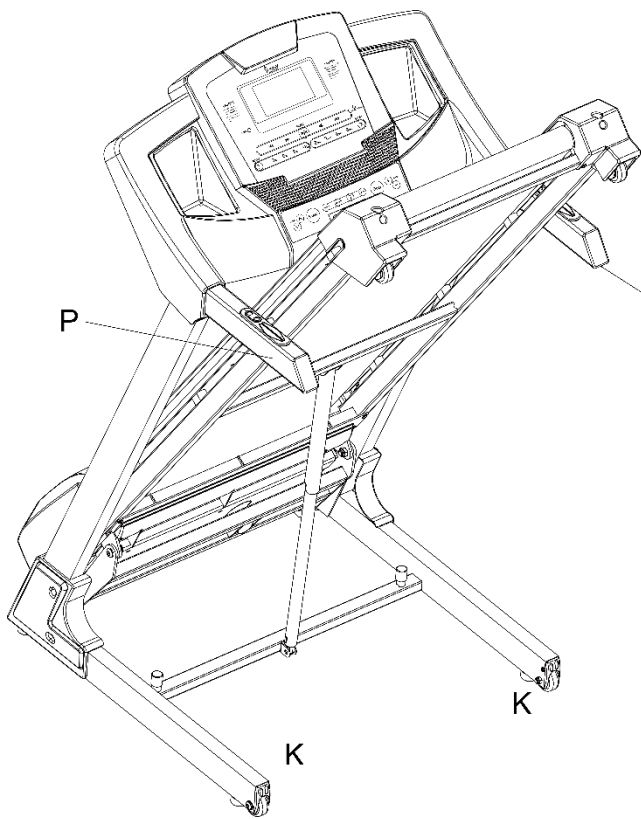

Before attempting to move the treadmill, make sure that it has been properly folded. Then, unplug the power cord.

To tilt, start by placing one hand at position "P" to support the top end of the treadmill. Next, place one foot at position "K" to hold the bottom end of the treadmill steady. With your foot at "K", slowly tilt the top of the treadmill downward towards the ground. Once the Main Frame "P" reaches a low enough point, the wheels of the treadmill will touch the ground.

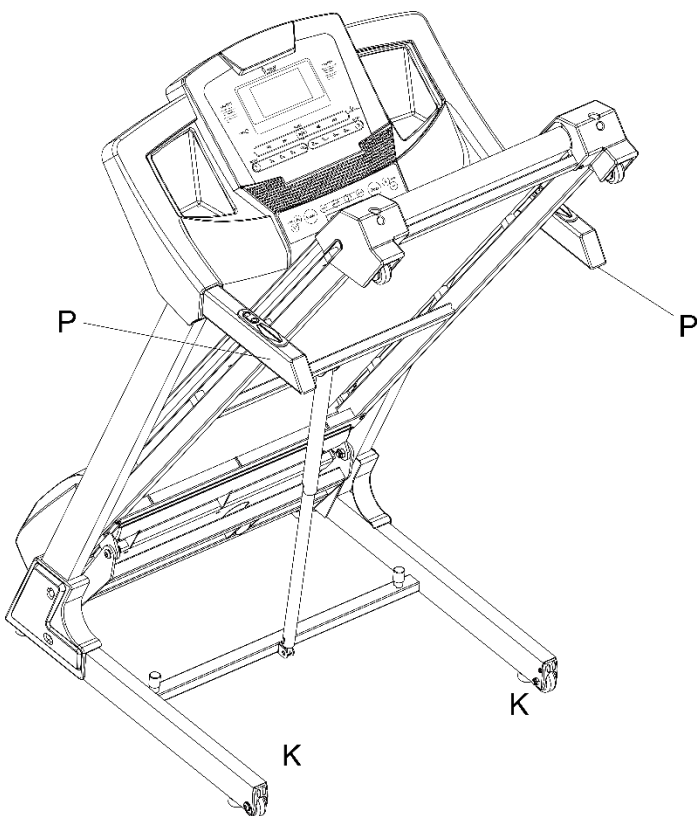

To transport, hold the treadmill from position "P" and tilt until the wheel's "K" are able to move on the ground.

IMPORTANT ELECTRICAL INFORMATION

IMPORTANT NOTE: This treadmill requires a power source of **110 Volts** in order to properly operate. For your safety, as well as the safety of others, please verify that the power source is correct before powering the equipment. Any power supply source above or below this level could cause significant damage to the equipment and/or user.

GROUNDING METHODS:

This product must be grounded. Should the treadmill malfunction or breakdown, grounding provides a path of least resistance for electric current to reduce the risk of electric shock. This product is equipped with a plug that has an equipment-grounding conductor and a grounding plug. The plug must be plugged into an appropriate outlet that is properly installed and grounded in accordance with all local codes and ordinances.

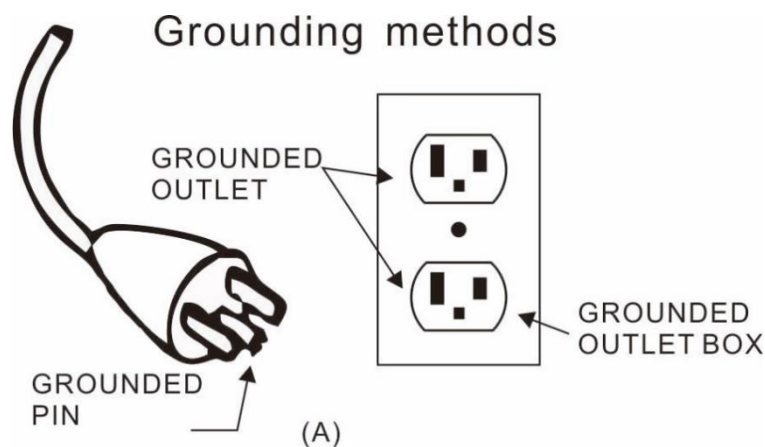

CAUTION:

Improper connection of the equipment can result in risk of electric shock. Check with a qualified electrician or serviceman if you are unsure whether the product has been properly grounded. Do not modify the plug provided with this product. If it will not fit the outlet, have a proper outlet installed by a qualified electrician. Ensure that the product is connected to an outlet with the same configuration as the plug. Do not use an adaptor for this product.

WARNING!

1. **NEVER** use a ground fault circuit interrupt (GFCI) outlet with this treadmill. Route the power cord away from all moving parts of the treadmill, including the Air Pressure Cylinder and transportation wheels.
2. **NEVER** operate the treadmill using a generator or UPS power supply.
3. **NEVER** remove any cover on this treadmill without first disconnecting the power cord.
4. **NEVER** expose the treadmill to rain or moisture. This treadmill is not designed for outdoor use or use in any high humidity environment.

THE DISPLAY CONSOLE

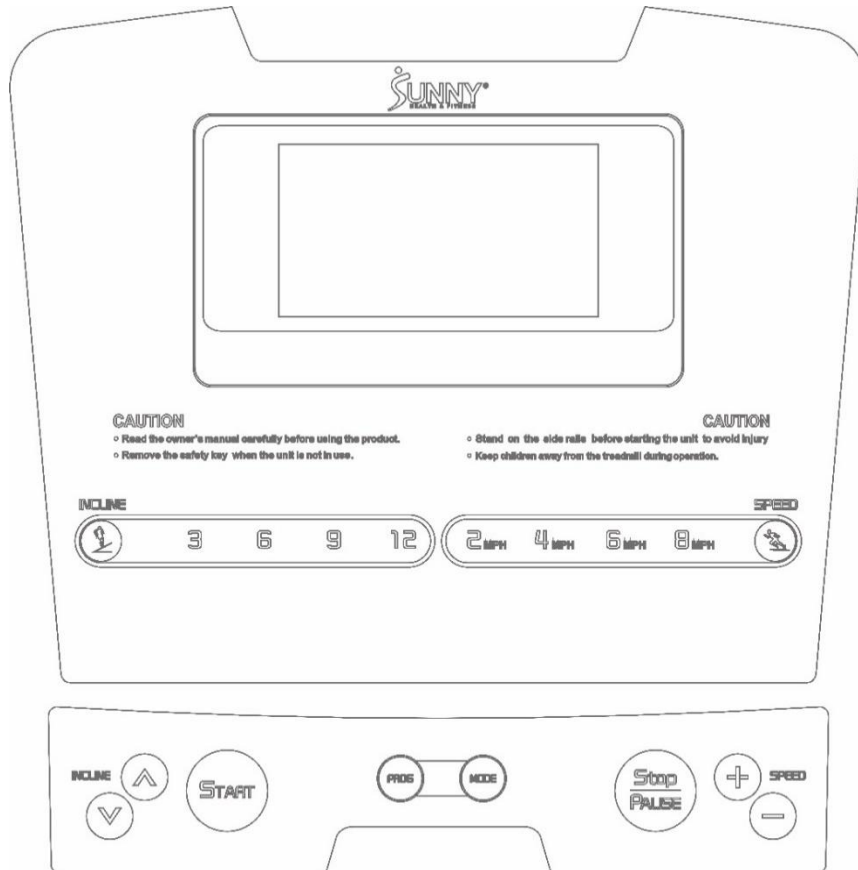

DISPLAY

The treadmill will start after a 3 seconds countdown.

1. **PROGRAM:** In addition to manual mode, there are 12 preset programs and 3 countdown functions.
2. **SPEED:** The speed range is 1- 8 MPH (1-12 KM/H). The initial default speed is 1 MPH (1 KM/H).
3. **TIME:** Displays the time elapsed (0:00-99:59 MINS). If the time reaches 99:59, the treadmill will stop smoothly and display “End” then automatically reset to 0:00 after 10 seconds. When in Countdown Mode, it will count from the set time to 0:00. When the clock reaches 0:00, the treadmill will stop smoothly and display “End” then automatically reset itself after 10 seconds.
4. **DISTANCE:** Displays the total distance traveled or distance countdown (0.00- 99.9 MILES) / (0.00-99.9 KM). Displayed every 5 seconds.
5. **CALORIES:** Displays total calories burned or calories countdown (0.0-999 KCAL). Displayed every 5 seconds.
6. **INCLINE:** Displays the current incline (0-12 INCLINE).
7. **PULSE:** Displays your pulse data when hands are placed on the sensors (50-200 BPM).
8. **SAFETY KEY:** The safety key lock acts as an emergency stop function. In case of emergency, simply remove the **Safety Key (No. 1)** from the top console and the top console will beep twice and bring the running belt to a complete stop.

9. **STEP:** Displays the total steps (1-99999 steps). Displayed every 5 seconds.

Convert from Imperial System to Metric System

First, remove the **Safety Key (No. 1)** from **Top Console (No. 89)** then press “PROG” and MODE” buttons together for 5 seconds. The display will show “8” or “12”. For Imperial System, insert the **Safety Key (No. 1)** to **Top Console (No. 89)** when “12” is displayed”. For Metric system, insert the **Safety Key (No. 1)** to **Top Console (No. 89)** when “8” is displayed”.

Note: If treadmill is converted to Metric System, speed and distance will be measured in Kilometers and Kilometers/Hour.

FUNCTION KEYS/MANUAL MODE

1. **START:** Insert the **Safety Key (No. 1)** into the top console and press START to start the treadmill. The treadmill will initiate at the default running speed of **1 MPH (1 KM/H)**.
2. **STOP/PAUSE:** This button has functions of PAUSE and STOP. When in use, press this button once to PAUSE your workout and the current workout data will still be shown. Press STOP again to terminate your workout session completely and all data will be deleted and reset to the initial setting.
3. **SPEED +/- BUTTONS:** During use, press these +/- keys to increase or decrease your speed. The speed will adjust 0.1 MPH (0.1 KM/H) at a time.
4. **PROG (PROGRAM) BUTTON:** Press the PROG button while the treadmill is not running to manually cycle through and choose a program. Programs range from P1-P12, 3 personalized user programs U1-U3 and FAT calculation.
5. **MODE BUTTON:** Press this button to choose which *Countdown Mode* to preset before starting the treadmill. H-1 is the TIME Countdown, H-2 is the DISTANCE Countdown, and H-3 is the CALORIES Countdown. Press the SPEED +/- keys to increase or decrease from the set data and/or press the START button to start this exercise.
6. **2MPH, 4MPH, 6MPH, 8MPH (QUICK SPEED KEYS):** Use these quick speed keys to instantly bring the running belt to the desired speed of 2MPH, 4MPH, 6MPH, or 8MPH. If the treadmill is converted to Metric System, the quick speed buttons will display 3 KM/H, 6 KM/H, 9 KM/H, 12 KM/H.
7. **3, 6, 9, 12 (QUICK INCLINE KEYS):** Use these quick incline keys to instantly bring the treadmill to an incline of 3, 6, 9, or 12.

COUNTDOWN MODE

1. Press the MODE button to select **H-1 (TIME)**, **H-2 (DISTANCE)**, or **H-3 (CALORIES)** Countdown.
2. Set the desired TIME, DISTANCE, or CALORIES setting to countdown from.
3. Press START to begin this exercise.

H-1 (TIME): Countdown is set at the initial time setting of 30:00 MINS. You may increase or decrease the set time by pressing the SPEED +/- keys. The TIME setting range is from 5:00-99:00 MINS.

H-2 (DISTANCE): Countdown is set at the initial distance setting of 1.00 MILE (1.00 KM). You may increase or decrease the set distance by pressing the SPEED +/- keys. The DISTANCE setting range is from 1.00-99.0 MILES (1.00-99.0 KM).

H-3 (CALORIES): Countdown is set at the initial calories setting of 50.0 KCAL. You may increase or decrease the set calories by pressing the SPEED +/- keys. The CALORIES setting range is

from 20.0-990 KCAL.

NOTE: Once the Countdown Mode program is complete, the treadmill will stop, then return to Manual Mode.

PROGRAMS

Each program is divided into 10 exercise segments in an equal time division. Please use below chart for Imperial or Metric system.

Program in Imperial System (Miles/ Hour)

PROGRAM \ TIME		SET TIME/10									
		1	2	3	4	5	6	7	8	9	10
P1	SPEED	1.8	1.8	3.6	3.0	3.0	2.4	2.4	2.4	2.4	1.8
	INCLINE	0	3	3	3	4	4	4	1	1	0
P2	SPEED	1.8	1.8	2.4	2.4	3.0	3.0	3.0	3.6	3.6	2.4
	INCLINE	2	2	2	3	3	3	3	4	4	2
P3	SPEED	1.2	2.4	3.6	4.8	4.2	4.8	3.6	1.2	1.8	1.2
	INCLINE	3	5	4	4	3	4	4	3	4	2
P4	SPEED	1.8	1.8	3.0	3.6	4.2	3.6	3.0	2.4	1.8	1.8
	INCLINE	0	3	3	2	2	5	5	3	3	2
P5	SPEED	1.8	3.6	3.6	3.6	4.8	4.2	4.2	3.0	3.0	2.4
	INCLINE	3	5	3	4	2	3	4	2	3	2
P6	SPEED	1.2	3.6	3.0	2.4	4.8	4.2	3.0	1.8	1.8	1.2
	INCLINE	3	4	5	6	3	5	5	6	4	3
P7	SPEED	1.2	5.4	5.4	4.2	4.2	4.2	3.0	1.8	1.2	1.2
	INCLINE	0	3	3	3	4	4	4	1	1	0
P8	SPEED	1.2	2.4	2.4	2.4	3.0	3.6	4.8	4.8	3.6	1.2
	INCLINE	1	1	4	4	4	5	5	4	3	2
P9	SPEED	1.2	2.4	3.0	3.0	3.6	3.0	3.0	1.8	1.8	1.2
	INCLINE	3	5	3	4	2	3	4	2	3	2
P10	SPEED	1.2	3.0	4.2	3.0	4.8	3.6	3.0	1.2	2.4	1.8
	INCLINE	1	5	6	8	12	9	10	9	5	3
P11	SPEED	1.2	3.0	3.6	4.2	4.8	5.4	6.0	3.0	1.8	1.2
	INCLINE	3	5	6	8	6	5	8	7	5	2
P12	SPEED	1.2	1.8	3.0	3.6	4.8	3.6	5.4	3.6	3.0	1.8
	INCLINE	5	7	5	8	6	5	9	10	6	2

Program in Metric System (Kilometers/ Hour)

TIME MODE		SET TIME/10									
		1	2	3	4	5	6	7	8	9	10
P1	SPEED	3	3	6	5	5	4	4	4	4	3
	INCLINE	0	3	3	3	4	4	4	1	1	0
P2	SPEED	3	3	4	4	5	5	5	6	6	4
	INCLINE	2	2	2	3	3	3	3	4	4	2
P3	SPEED	2	4	6	8	7	8	6	2	3	2
	INCLINE	3	5	4	4	3	4	4	3	4	2
P4	SPEED	3	3	5	6	7	6	5	4	3	3
	INCLINE	0	3	3	2	2	5	5	3	3	2
P5	SPEED	3	6	6	6	8	7	7	5	5	4
	INCLINE	3	5	3	4	2	3	4	2	3	2
P6	SPEED	2	6	5	4	8	7	5	3	3	2
	INCLINE	3	4	5	6	3	5	5	6	4	3
P7	SPEED	2	9	9	7	7	6	5	3	2	2
	INCLINE	0	3	3	3	4	4	4	1	1	0
P8	SPEED	2	4	4	4	5	6	8	8	6	2
	INCLINE	1	1	4	4	4	5	5	4	3	2
P9	SPEED	2	4	5	5	6	5	6	3	3	2
	INCLINE	3	5	3	4	2	3	4	2	3	2
P10	SPEED	2	5	7	5	8	6	5	2	4	3
	INCLINE	1	5	6	8	12	9	10	9	5	3
P11	SPEED	2	5	6	7	8	9	10	5	3	2
	INCLINE	3	5	6	8	6	5	8	7	5	2
P12	SPEED	2	3	5	6	8	6	9	6	5	3
	INCLINE	5	7	5	8	6	5	9	10	6	2

USER PROGRAMS (U1-U3):

Each program is made up of 10 segments. User Programs allow you to personalize each segment of your exercise program by programming each individual segment's time duration, desired speed, and incline.

To begin, press the PROG button to select U1, U2, or U3 then press MODE to enter the setting mode and set the TIME of the 1st segment. Next, set the desired SPEED of the 1st segment by pressing the SPEED +/- keys and set the INCLINE by pressing the INCLINE +/- keys. Press MODE and your 1st segment is set.

The next workout segment will flash. Repeat the instructions above until you've completed programming all 10 segments.

FAT CALCULATION:

Press the PROGRAM button until the window displays FAT. Press MODE to enter your (F1) Gender, (F2) Age, (F3) Height, and (F4) Weight. Press the SPEED +/- keys to set the data accordingly. After you've set up F1~F4, F5 will display on the screen. Hold the hand pulse sensors and the BMI calculator will display your FAT.

NOTE: Average Body Mass Index score is 20-25%

Underweight: Below 19.0
Normal: 20.0 – 25.0
Overweight: 26.0 – 29.0
Obesity: 30.0 – and above

BODY MASS INDEX CHART:

F-1	Sex	01 MALE	02 FEMALE
F-2	Age	10 to 99 YEARS OLD	
F-3	Height	40---80 INCHES (100-220 CM)	
F-4	Weight	44---330 LBS (20-150 KG)	
F-5	FAT	≤19	Underweight
	FAT	=(20---25)	Normal Weight
	FAT	=(26---29)	Overweight
	FAT	≥30	Obesity

APP CONNECTION

1. Scan the QR code below to download the SunnyFit app to your mobile device.



2. If this is your first time using the SunnyFit app, follow the in-app instructions to register for your free SunnyFit account and log in.
3. Ensure that the Bluetooth  function is turned on from your mobile device.
4. To connect the equipment to the SunnyFit app:
 - a. From the “Workout” tab, press on the “Search” button to search for your equipment.
 - b. Once your equipment appears on the list, tap the “Select” button to confirm.
 - c. Note: If your equipment does not appear on the "Searching for Equipment" list, check the EXERCISE CONSOLE on your equipment to ensure that it is not in sleep mode and your phone's Bluetooth function is on, then tap "Retry" to search again.
 - d. Once your equipment shows up on the “Workout” tab as “Currently Selected”, your equipment is now ready to display, track, and record your equipment’s workout stats on the app!
5. If you are unable to replicate these steps, or have any other issues with the SunnyFit app, please contact SunnyFit support at support@sunnyfit.com, or use the in-app “Contact Us” form to request support (“Me” tab -> “Contact Us”).

EXERCISE INSTRUCTIONS

GETTING STARTED:

Before starting any exercise programs, you should consult your physician to determine if you have any medical or physical conditions that could put your health and safety at risk or prevent you from using the equipment properly. Be aware of your body's signals. Incorrect or excessive exercise can damage your health. Stop exercising immediately if you experience any of the following symptoms: pain, tightness in your chest, irregular heartbeat, extreme shortness of breath, lightheadedness, dizziness, or feelings of nausea.

Turn on the power switch located next to the power cord. Get to know your treadmill. Before attempting to use the treadmill take some time to stand alongside it and familiarize yourself with the controls. Once you feel comfortable get on, you can stand with your feet on the foot rails and balance yourself by putting your hands on the handrails.

Next, attach the clip end of the **Safety Key (No. 1)** to your clothing and insert the magnetic end of the key into the top console. Press the START button to start the treadmill. The treadmill will start at the default speed of 1 MPH (1 KM/H). Once you feel comfortable, you may slowly increase the speed. When you are finished with your exercise, press the STOP button or remove the magnetic end of **Safety Key (No. 1)** to stop the treadmill.

SAFETY LOCK:

Remove the **Safety Key (No. 1)** from the top console to stop the treadmill immediately. Once the treadmill reaches a full stop, the window display on the top console will show "---" and the treadmill will beep. To start the treadmill again, insert the magnetic end of **Safety Key (No. 1)** into the top console and press START.

POWER SAVE FUNCTION:

Once the treadmill has been inactive for 10 minutes, it will adjust to *Power Saving Mode*. When the treadmill is in *Power Saving Mode*, the window display on the top console will shut off. To reactivate, press any key.

POWER OFF:

Power to the treadmill can be turned off at any time without risk during or after an exercise.

CAUTION!

1. We recommend that you maintain a slow speed at the beginning of a session and hold the handrails until you become comfortable and familiar with the treadmill.
2. Insert the magnetic end of the safety key into the top console and attach the opposite end with the safety clip to your clothing before beginning your workout. To end your workout, press the STOP button or remove the safety key. The treadmill will stop immediately.

TROUBLESHOOTING

Code	Description	How to Troubleshoot
----	Safety key fault.	<ol style="list-style-type: none"> 1. Insert the safety key properly. 2. Replace the safety key sensor or safety key. If there's still a problem, replace the top console.
E01	Communication abnormality: no communication from the top console to the control board.	<p>Possible Reasons: Communication obstructed between control board and top console, please check to make sure the wires are connected properly, and the wires are without any punctures or damage.</p> <p>If this does not resolve the issue, check the control board and PCB IC to see if there's any damage, replace if necessary.</p>
E02	Motor fault or control board fault.	<ol style="list-style-type: none"> 1. Check if the motor cable is well connected. Reconnect the wire and restart. 2. Check the motor or the control board for any damage. Replace if necessary.
E04	Incline failure: the incline motor sensor wire is damaged or the wire for the incline motor is not properly connected.	Check incline motor sensor wire and AC wire to see if they are properly connected. Make sure the incline motor wire does not have any punctures or damage.
E05	Current overload protection.	<p>Possible Reasons: Excessive current load, the incoming voltage is too low or too high. The control board is damaged. A moving part of the treadmill is stuck, and the motor is unable to function properly.</p> <p>Try to restart the treadmill. Also, check if there's any burnt odors around the motor and control board. Make sure the power and voltage comply with the standard. Inspect moving parts to ensure they are operating correctly. Listen for unfamiliar noises from the motors.</p>
E06	Burst clash protection.	<p>Possible Reasons: The power voltage is less than normal by 50% or the controller has problems. Make sure the motor wires are connected. Check the control board for any damage or burnt odors. Replace if necessary.</p>
No display in console	Control board abnormality.	<ol style="list-style-type: none"> 1. Check if the overload button switch is off, if so, press to turn it on. 2. Check the wire on the power switch, overload button, and control board to see if it is connected properly. 3. Check the top console wires and all cables between the top console and control board. 4. Check the transformer and replace if necessary.

EXPLODED DIAGRAM

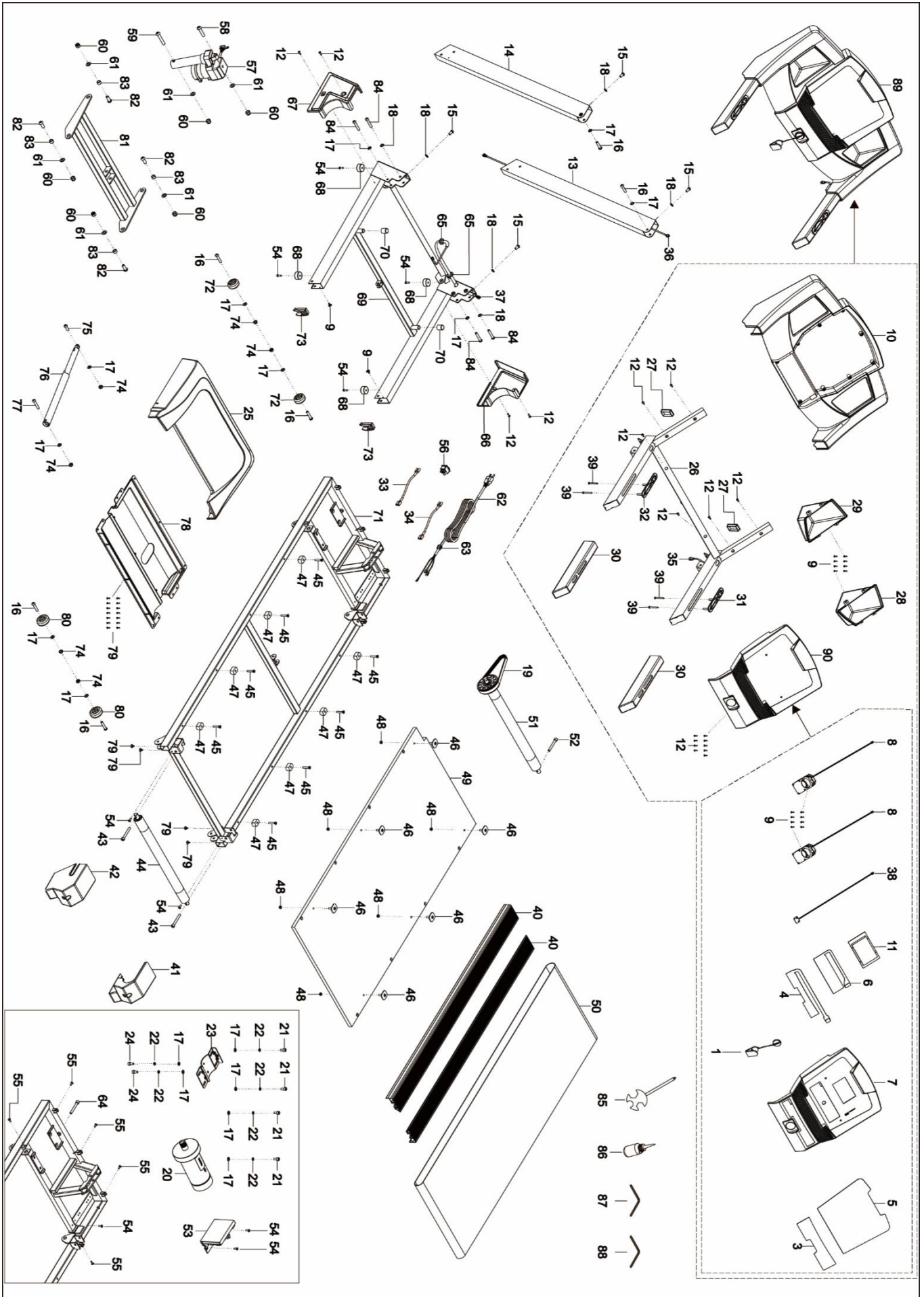

PARTS LIST

No.	Description	Spec.	Qty.
1	Safety Key		1
2	NA		
3	Key Panel Sticker		1
4	Lower Metal Dome Array		1
5	Overlay		1
6	Upper Metal Dome Array		1
7	Console Panel	413*356*52	1
8	Speaker		2
9	Cross Recessed Pan Head Tapping Screw	ST4.2*8	18
10	Top Cover	715*435*130	1
11	Console Chip		1
12	Cross Recessed Pan Head Tapping Screw	ST4.2*16	19
13	Left Support Tube		1
14	Right Support Tube		1
15	Half-roundhead Hex Bolt	M8*15	4
16	Roundhead Hex Bolt	M8*40 thread L15	6
17	Flat Washer	Φ16*Φ8.5*1.2	16
18	Serrated Gasket	D8	6
19	Motor Belt	190J6	1
20	DC Motor		1
21	Roundhead Hex Bolt	M8*15	4
22	Spring Washer	M8	6
23	Motor Bracket	159*90*3	1
24	Roundhead Hex Bolt	M8*12	2
25	Motor Cover	592*343*121	1
26	Console Bracket		1
27	Pipe Plug	50*30*10	2
28	Bottle Holder (R)	191*135*154	1
29	Bottle Holder (L)	191*135*154	1
30	Handrail Bushing	300*50*30	2
31	Speed Hand Pulse		1
32	Incline Hand Pulse		1
33	Single Brown Wire	250mm	1
34	Single Blue Wire	250mm	1
35	Upper Console Wire	800mm	1
36	Middle Console Wire	1000mm	1
37	Lower Console Wire	500mm	1
38	Safety Key Sensor		1
39	Cross Recessed Pan Head Tapping Screw	ST4.2*45	4
40	Side Rail	1160*80*34	2
41	End Cap (R)	156*94*155	1
42	End Cap (L)	156*94*155	1
43	Roundhead Hex Bolt	M8*55	2
44	Rear Roller	42*517	1
45	Cross Recessed Sunk Head Screw	M6*40 thread L10	8

No.	Description	Spec.	Qty.
46	Side Rail Support		6
47	Cushion	Φ30*20*16	8
48	Lock Nut	M6	6
49	Running Board	1210*574*15	1
50	Running Belt	2720*420*1.6	1
51	Front Roller	42*533	1
52	Roundhead Hex Bolt	M8*50	1
53	Controller		1
54	Cross Roundhead Screw	M5*15	9
55	Cross Roundhead Screw	M5*10	5
56	Power Switch		1
57	Incline Motor		1
58	Half-roundhead Hex Bolt	M10*45 thread L25	1
59	Half-roundhead Hex Bolt	M10*60 thread L15	1
60	Lock Nut	M10	6
61	Flat Washer	Φ20*Φ10.5*2	6
62	Power Line	2100mm	1
63	Power Line Plug	N3	1
64	Roundhead Hex Bolt	M8*15 thread L15	1
65	Cable Protector	Φ24*Φ18*Φ12*9	2
66	Right Side Cover	225*183*52	1
67	Left Side Cover	225*183*52	1
68	Flat Foot Pad	Φ31.5*Φ6*16	4
69	Base Frame		1
70	Round Cushion	Φ20*Φ16*17.5	2
71	Main Frame		1
72	Transportation Wheel	Φ45*Φ8.2*20	2
73	Transportation Wheel Cover	60*30*18.8	2
74	Lock Nut	M8	6
75	Half-roundhead Hex Bolt	M8*25 thread L15	1
76	Cylinder		1
77	Half-roundhead Hex Bolt	M8*45 thread L10	1
78	Motor Bottom Cover	570*340*48	1
79	Screw	ST4.2*16	18
80	Moving Wheel	Φ45*Φ8.2*20	2
81	Incline Bracket		1
82	Half-roundhead Hex Bolt	M10*25 thread L20	4
83	Incline Bushing	Φ15*Φ9*8.2	4
84	Half-roundhead Hex Bolt	M8*45 thread L15	4
85	Spanner with Screwdriver		1
86	Silicone Oil		1
87	Allen Wrench	S5	1
88	Allen Wrench	S6	1
89	Top Console	1421SS3	1
90	Console		1

CONNECT WITH US

FOR FITNESS ARTICLES, VIDEOS & WORKOUTS



@SUNNYHEALTHANDFITNESS



@SUNNYHEALTHFITNESS



@SUNNYHEALTHFIT



/SUNNYHEALTHFITNESS



/SUNNYHEALTHANDFITNESS



@SUNNYHEALTHFITNESS

WWW.SUNNYHEALTHFITNESS.COM