



NIMBLE SMART COMPACT TREADPAD TREADMILL SF-T722072 USER MANUAL



IMPORTANT! Please retain owner's manual for maintenance and adjustment instructions. Your satisfaction is very important to us, **PLEASE DO NOT RETURN UNTIL YOU HAVE CONTACTED US:** support@sunnyhealthfitness.com or 1- 877 - 90SUNNY (877-907-8669).



WWW.SUNNYHEALTHFITNESS.COM

IMPORTANT SAFETY INSTRUCTION

When using an electrical appliance, basic precautions should always be followed, including the following:

Read all instructions before using (this appliance).

DANGER –To reduce the risk of electric shock:

Always unplug this appliance from the electrical outlet immediately after using and before cleaning.

WARNING – To reduce the risk of burns, fire, electric shock, or injury to persons:

1. An appliance should never be left unattended when plugged in. Unplug from outlet when not in use, and before putting on or taking off parts.
2. This appliance is not intended for use by persons with reduced physical, sensory, or mental capabilities, or lack of experience and knowledge, unless they have been given supervision or instruction concerning use of the appliance by a person responsible for their safety. Keep children under the age of 13 away from this machine.
3. Use this appliance only for its intended use as described in this manual. Do not use attachments not recommended by the manufacturer.
4. Never operate this appliance if it has a damaged cord or plug, if it is not working properly, if it has been dropped or damaged, or dropped into water. Return the appliance to a service center for examination and repair.
5. Do not carry this appliance by supply cord or use cord as a handle.
6. Keep the cord away from heated surfaces.
7. Never operate the appliance with the air openings blocked. Keep the air openings free of lint, hair, and the like.
8. Never drop or insert any object into any opening.
9. Do not use outdoors. Household use only.
10. Do not operate where aerosol (spray) products are being used or where oxygen is being administered.
11. To disconnect, turn all controls to the off position, then remove plug from outlet.
12. CAUTION: Risk of Injury to Persons – To Avoid Injury, use extreme caution when stepping onto or off of a moving belt. Read Instruction Manual Before Using.
13. Connect this appliance to a properly grounded outlet only. See Grounding Instructions.
14. REMOVE CONTROL BOX (OR KEY, OR SAFETY PIN, AS APPLICABLE) WHEN NOT IN USE, AND STORE OUT OF REACH OF CHILDREN.

SAVE THESE INSTRUCTIONS

Caution: The user is cautioned that changes or modifications not expressly approved by the party responsible for compliance could void the user's authority to operate the equipment.

This device contains license-exempt transmitter(s)/receiver(s) that comply with Innovation, Science and Economic Development Canada's license-exempt RSS(s) and Part 15 of the FCC Rules. Operation is subject to the following two conditions:

- 1) This device may not cause interference.
- 2) This device must accept any interference, including interference that may cause undesired operation of the device.

NOTE: This equipment has been tested and found to comply with the limits for a Class B digital device, pursuant to Part 15 of the FCC Rules. These limits are designed to provide reasonable protection against harmful interference in a residential installation. This equipment generates, uses, and can radiate radio frequency energy and, if not installed and used in accordance with the instructions, may cause harmful interference to radio communications. However, there is no guarantee that interference will not occur in a particular installation.

If this equipment does cause harmful interference to radio or television reception, which can be determined by turning the equipment off and on, the user is encouraged to try to correct the interference by one or more of the following measures:

- Reorient or relocate the receiving antenna.
- Increase the separation between the equipment and receiver.
- Connect the equipment into an outlet on a circuit different from that to which the receiver is connected.
- Consult the dealer or an experienced radio/TV technician for help.

FCC & IC Radiation Exposure Statement:

This equipment complies with FCC and Canada radiation exposure limits set forth for an uncontrolled environment. This equipment should be installed and operated with a minimum distance of 20cm between the radiator and your body.

This transmitter must not be co-located or operating in conjunction with any other antenna or transmitter.

IMPORTANT SAFETY INFORMATION

We thank you for choosing our product. To ensure your safety and health, please use this equipment correctly. It is important to read this entire manual before assembling and using the equipment. Safe and effective use can only be achieved if the equipment is assembled, maintained, and used properly. It is your responsibility to ensure that all users of the equipment are informed of all warnings and precautions.

1. Before starting any exercise program, you should consult your physician to determine if you have any medical or physical conditions that could put your health and safety at risk or prevent you from using the equipment properly. Your physician's advice is essential if you are taking medication that affects your heart rate, blood pressure or cholesterol level.
2. Be aware of your body's signals. Incorrect or excessive exercise can damage your health. Stop exercising if you experience any of the following symptoms: pain, tightness in your chest, irregular heartbeat, shortness of breath, lightheadedness, dizziness, or feelings of nausea. If you do experience any of these conditions, you should consult your physician before continuing with your exercise program.
3. Keep children and pets away from the equipment. The equipment is designed for adult use only.
4. Use the equipment on a solid, flat level surface with a protective cover for your floor or carpet. To ensure safety, the equipment should have at least 8 feet (240CM) of free space behind it and 2 feet (60 CM) on each side. Do not place the treadmill on any surface that blocks air openings. To protect the floor or carpet from damage, place a mat under the treadmill.
5. Ensure that all nuts and bolts are securely tightened before using the equipment. The safety of the equipment can only be maintained if it is regularly examined for damage and/or wear and tear.
6. Always use the equipment as indicated. If you find any defective components while assembling or checking the equipment, or if you hear any unusual noises coming from the equipment during exercise, discontinue use of the equipment immediately and do not use until the problem has been rectified.
7. Wear suitable clothing while using the equipment. Avoid wearing loose clothing that may become entangled in the equipment.
8. Do not place fingers or objects into the moving parts of the equipment.
9. The maximum weight capacity of this unit is 245 pounds (110 kgs).
10. The equipment is not suitable for therapeutic use.
11. To avoid bodily injury and/or damage to the product or property, proper lifting and moving is required.
12. Your product is intended for use in cool, dry conditions. You should avoid storage in extreme cold, hot, or damp areas as this may lead to corrosion and other related problems.
13. This equipment is designed for indoor and home use only. It is not intended for commercial use!

IMPORTANT OPERATING INSTRUCTIONS

1. Insert the power plug directly into the socket.
2. Read the manual before operating the equipment.
3. Changes in speed do not occur immediately. Set your desired speed using the adjustment keys on the remote control. The speed will increase gradually.
4. While on the treadmill, move with caution as distractions may cause you to lose balance and stray from walking in the center of the belt. This may result in serious injury.
5. This unit starts at a very low speed. To begin use, stand on the side rails while it starts up, then step onto the belt once it's in motion.
6. A safety key is provided for emergency use. The treadmill will function only if the safety key is inserted into the console. In case of emergency, remove the safety key to immediately stop the belt and shut off the treadmill. The display screen will reset once the safety key is reinserted.
7. This equipment is designed for adult use only! Children should not be allowed to use or play near this equipment. When present, children should always be supervised by an adult.
8. Women who are pregnant or nursing should consult a physician before attempting to begin any exercise program.
9. Always stay hydrated during and after exercise.
10. Do not lift the treadmill.
11. The machine will stop automatically after 15 minutes, if not in use.









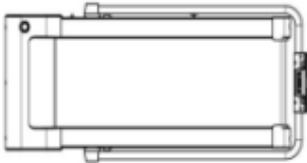

IMPORTANT NOTE:

The belt must be lubricated before the first use! Please see *Page 8* for instructions on how to properly apply lubricant.

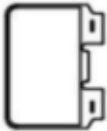
PRE-ASSEMBLY CHECK LIST

Before you start to assemble, please make sure all parts are included.

 A	 E07	 E13
 E19	 B	 C
 D	 E	 H

No.	Description	Spec.	Qty.
A	Main Frame		1
E07	Remote Control		1
E13	Power Cord		1
E19	Safety Key		1
B	Lubricant	20ml/bottle	1
C	Tablet Holder		1
D	Manual		1
E	Thank You Card		1
H	Screwdriver		1

Ordering Replacement Parts (U.S. and Canadian Customers only)

Please provide the following information in order for us to accurately identify the part(s) needed:

- ✓ The model number (found on cover of manual)
- ✓ The product name (found on cover of manual)
- ✓ The part number found on the “EXPLODED DIAGRAM” and “PARTS LIST” (found near the end of the manual)

Please contact us at support@sunnyhealthfitness.com or 1-877-90SUNNY (877-907-8669).

ASSEMBLY INSTRUCTIONS

We value your experience using Sunny Health and Fitness products. For assistance with parts or troubleshooting, please contact us at support@sunnyhealthfitness.com or 1-877-90SUNNY (877-907-8669).

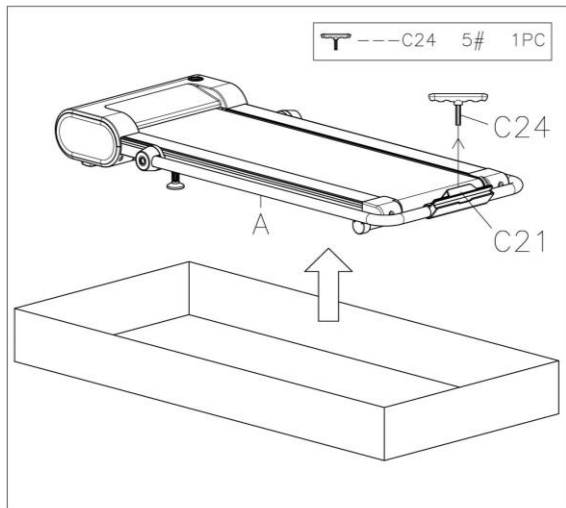

STEP 1:

Open the carton and remove contents. Place the **Main Frame (No. A)** on level ground, ensure that you have a work area that is clean and has adequate space.

Take the **T-Shape Wrench (No. C24)** out from the **Tablet Holder Bottom Cover (No. C21)**.

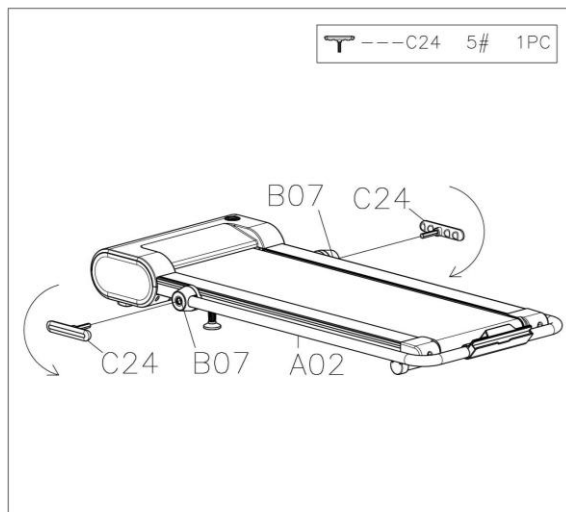

STEP 2:

Loosen the 2 **Screws (No. B07)** on the **Handlebar Tube (No. A02)** by turning counter-clockwise using the **T-Shape Wrench (No. C24)**.

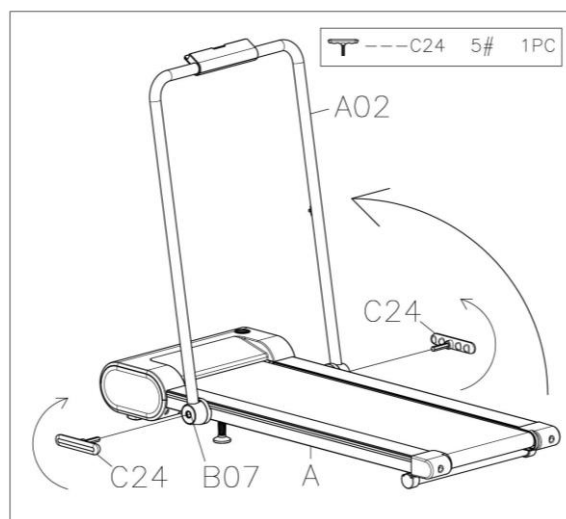

STEP 3:

Support the **Handlebar Tube (No. A02)** with your hands to prevent it from falling.

Attach **Handlebar Tube (No. A02)** to the **Main Frame (No. A)** with 2 **Screws (No. B07)** by turning clockwise using the **T-Shape Wrench (No. C24)**.

We value your experience using Sunny Health and Fitness products. For assistance with parts or troubleshooting, please contact us at support@sunnyhealthfitness.com or 1-877-90SUNNY (877-907-8669).

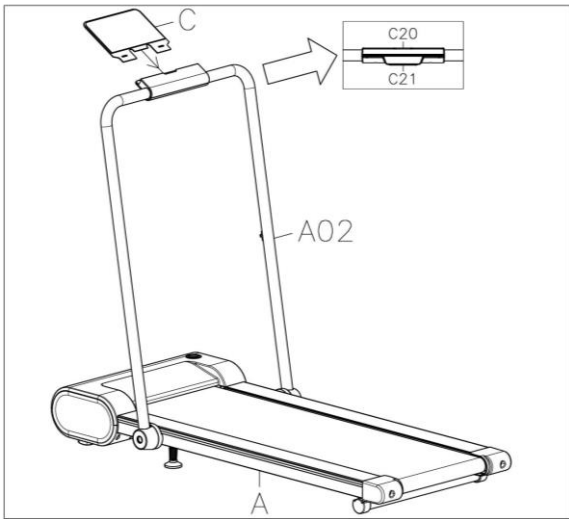

STEP 4:

Insert the **Tablet Holder (No. C)** into the **Tablet Holder Top and Bottom Covers (No. C20 & C21)**.

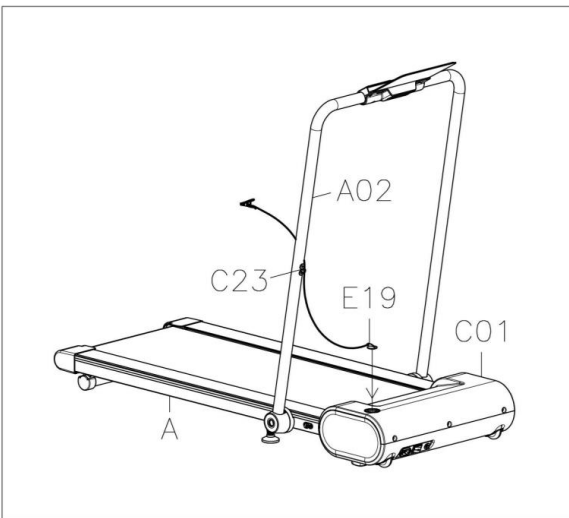

STEP 5:

Put the magnet end of **Safety Key (No. E19)** onto the **Motor Top Cover (No. C01)**.

When you are running, you can put the wire of **Safety Key (No. E19)** through **Lead Wire Buckle (No. C23)** on the **Handlebar Tube (No. A02)** and clip onto your clothes.

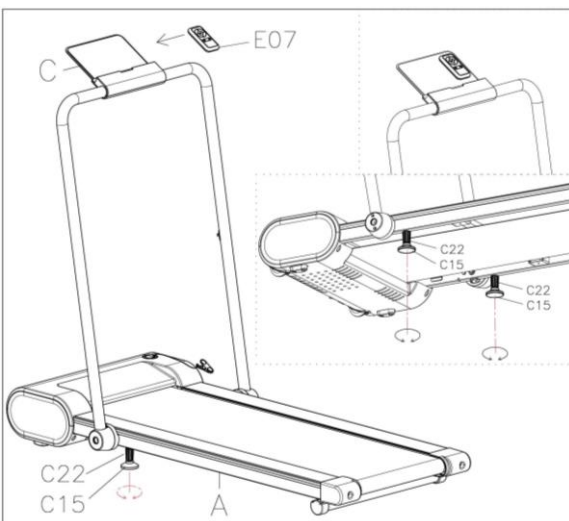

STEP 6:

Adjust the height of **Foot Pad Sleeve (No. C22)** to level the machine if it is not even on the ground.

The Remote Control (**No. E07**) can attach directly to the **Tablet Holder (No. C)**.

The assembly is complete!



IMPORTANT NOTE!

You will need to lubricate your treadmill before the first use.
See *Page 8*.

LUBRICATING THE TREADMILL

IMPORTANT NOTE:

You will need to lubricate your treadmill before the first use.

RUNNING BELT & TREADMILL LUBRICANT:

Lubricating the **Running Board (No. E21)** and **Running Belt (No. C07)** is essential as the friction affects the life span and operations of the treadmill. Inspect the **Running Belt (No. C07)** and **Running Board (No. E21)** regularly. If you find any wear on the **Running Board (No. E21)**, please contact us at: support@sunnyhealthfitness.com.

WARNING: Always unplug the treadmill from the electrical outlet before cleaning, lubricating, or repairing the unit.

HOW TO LUBRICATE:

1. To apply lubricant, lift one side of the **Running Belt (No. C07)** and apply oil to the middle of the **Running Board (No. E21)**. Next, start the treadmill and place it at the lowest speed setting and allow the oil to spread over the **Running Board (No. E21)**. Repeat this process for the other side.
2. The moving parts should turn freely and quietly. Abnormal moving parts will affect the safety of the equipment. Inspect and tighten bolts regularly.
3. To better maintain the treadmill and prolong its lifespan, it is suggested that maintenance be done on a regular basis.
4. **DO NOT LOOSEN OR MAKE ANY ADJUSTMENTS TO THE RUNNING BELT WHILE APPLYING LUBRICANT.** A loose **Running Belt (No. C07)** will result in the runner sliding off during use, while too tight of a **Running Belt (No. C07)** will negatively affect the motor's performance and create more friction between the roller and **Running Belt (No. C07)**. The most suitable tightness for the **Running Belt (No. C07)** is when it is pulled out **50-75mm** from the **Running Board (No. E21)**.

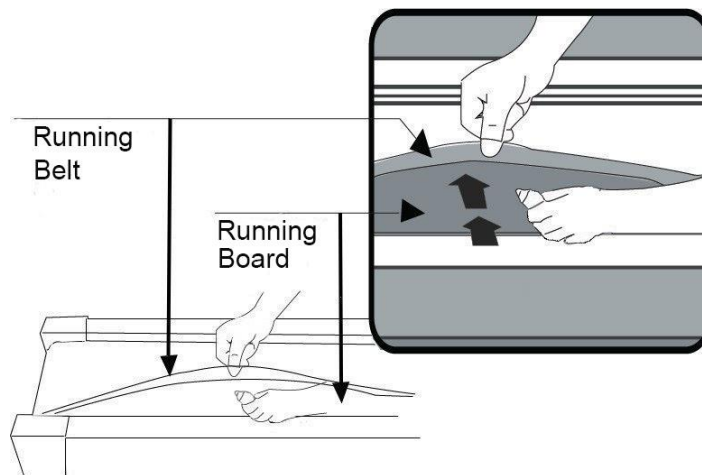

The following timetable is recommended:

Light user (less than 3 hours/ week)	<i>every six months</i>
Medium user (3-5 hours/ week)	<i>every three months</i>
Heavy user (more than 5 hours/ week)	<i>every two months</i>

HOW TO FOLD THE MACHINE

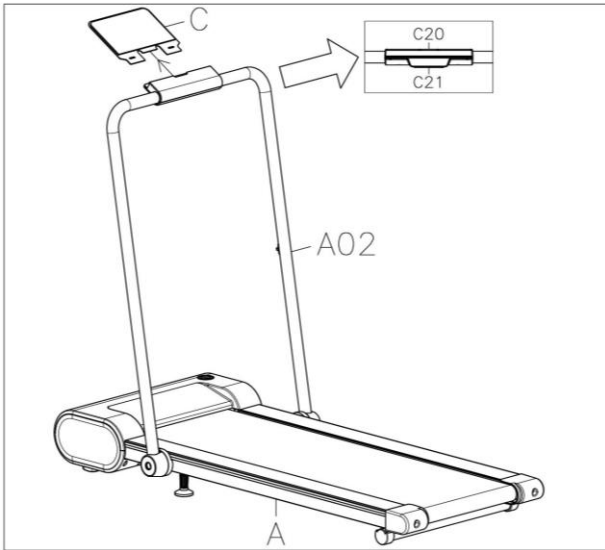

STEP 1:

Pull out the **Tablet Holder (No. C)** from **Tablet Holder Top and Bottom Cover (No. C20 & C21)**.

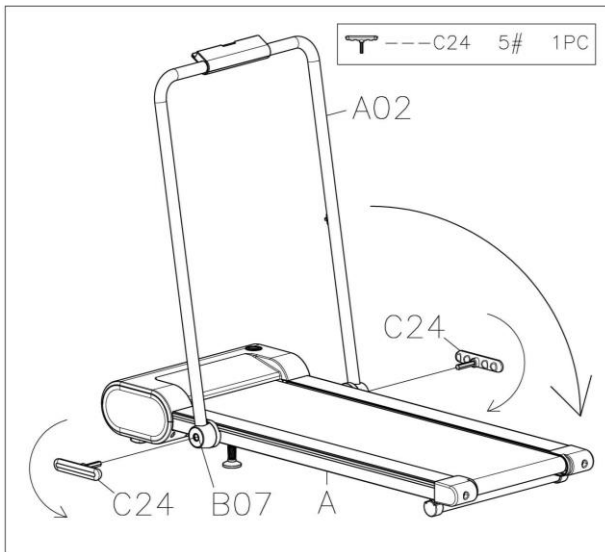

STEP 2:

Loosen the 2 **Screws (No. B07)** of the **Handlebar Tube (No. A02)** by turning counter-clockwise using the **T-Shape Wrench (No. C24)**.

Pull the **Handlebar Tube (No. A02)** downward (in the direction, as shown in the diagram).

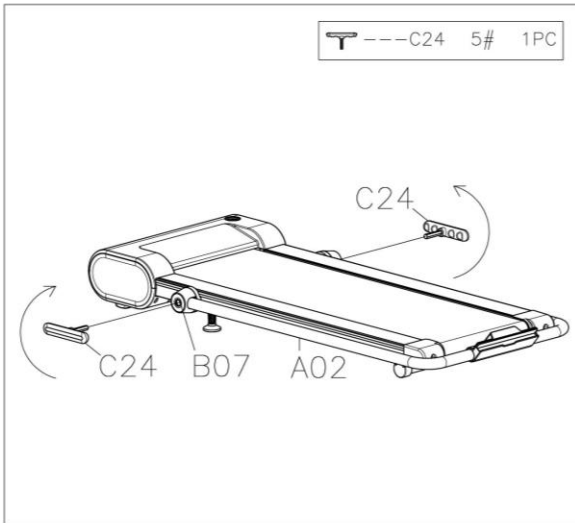

STEP 3:

Attach the 2 **Screws (No. B07)** on **Handlebar Tube (No. A02)** to the **Main Frame (No. A)** by turning clockwise using the **T-Shape Wrench (No. C24)**.

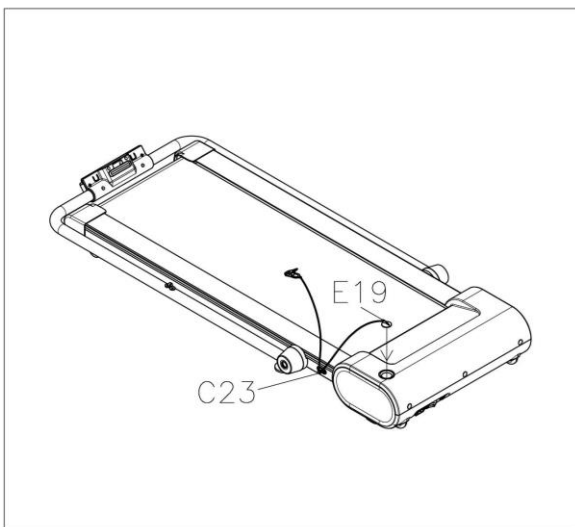

STEP 4:

Put the magnet end of **Safety Key (No. E19)** onto the **Motor Top Cover (No. C01)**.

When you are running, you can put the wire of **Safety Key (No. E19)** through **Lead Wire Buckle (No. C23)** on the **Main Frame (No. A)** and clip onto your clothes.

HOW TO MOVE THE MACHINE

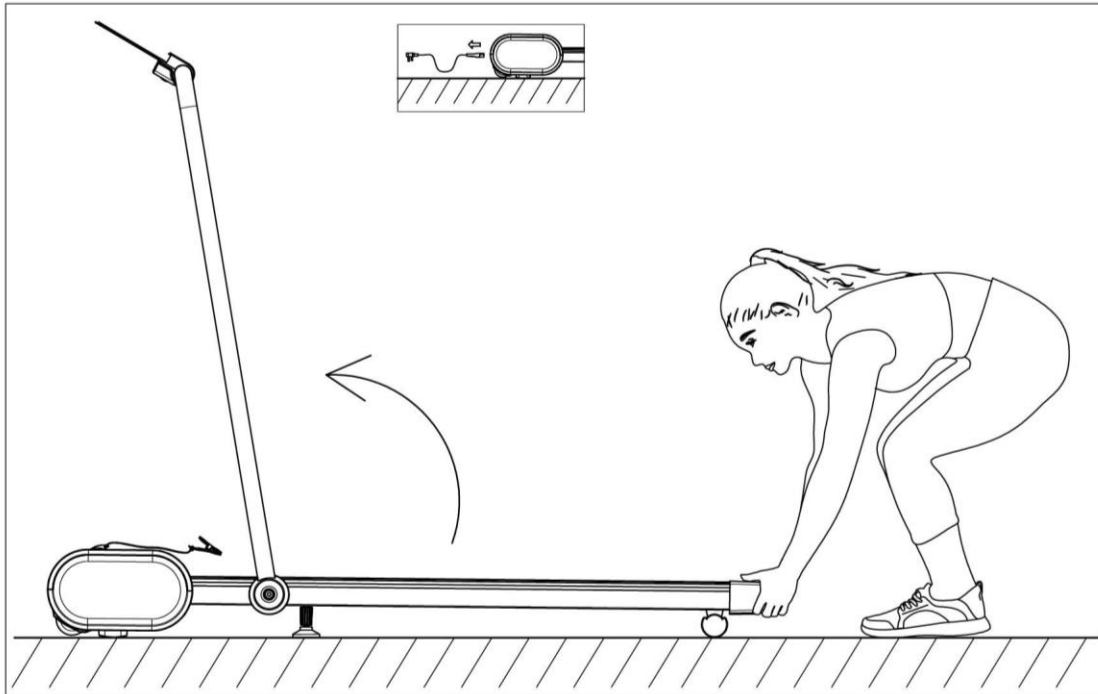

Note: Please unplug the power cord from the treadmill before moving.

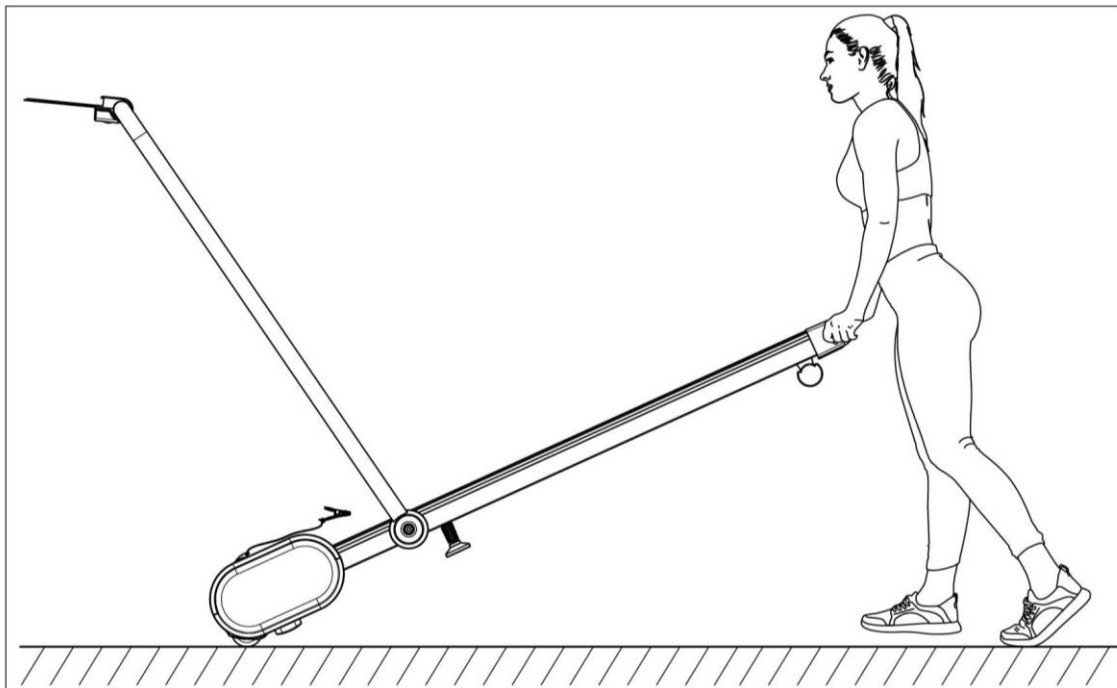

Hold the treadmill at position as above with your hand. Lift the treadmill and then you can move the treadmill to any place.

HOW TO USE SAFETY KEY

When the handrails stand up, the treadmill is in running mode. When you are running, you can put the wire of **Safety Key (No. E19)** through **Lead Wire Buckle (No. C23)** on the **Handlebar Tube (No. A02)** and clip onto your clothes.

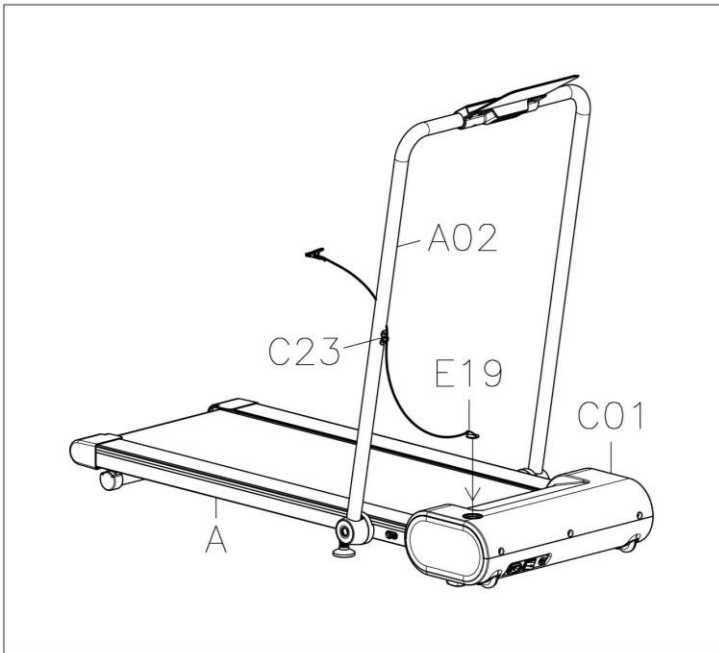

When the handrails lie down, the treadmill is in walking mode. When you are walking, you can put the wire of **Safety Key (No. E19)** through **Lead Wire Buckle (No. C23)** on the **Main Frame (No. A)** and clip onto your clothes.

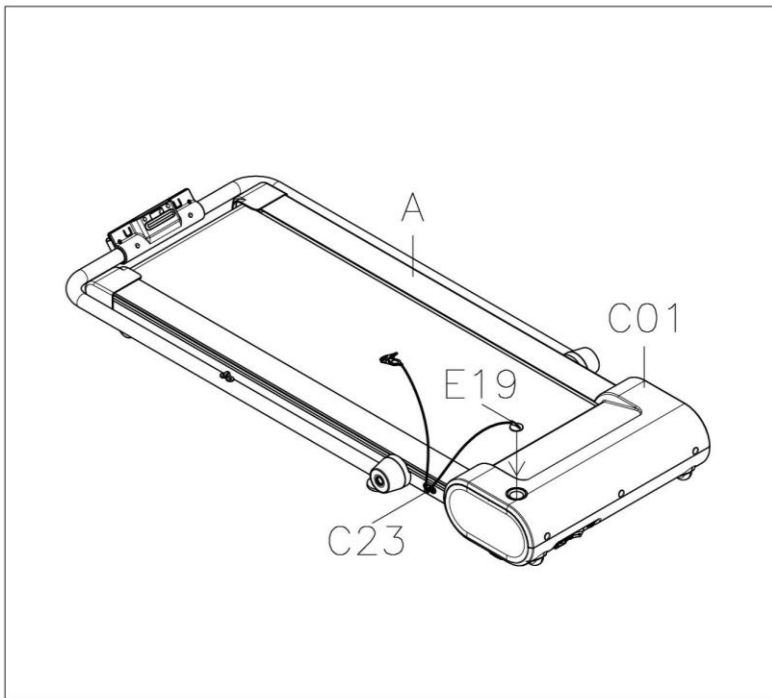

MAINTENANCE & CARE

General cleaning will help prolong the life and performance of your treadmill. Keep the unit clean and maintained by dusting the components on a regular basis. Clean both sides of the running belt to prevent dust from accumulating underneath the belt. Keep your running shoes clean so that dirt from your shoes does not wear out the **Running Board (No. E21)** and **Running Belt (No. C07)**. Clean the surface of the **Running Belt (No. C07)** with a clean damp cloth.

To better maintain the treadmill and prolong its life, it is suggested that the treadmill be powered off for 10 minutes every 2 hours and fully powered off whenever not in use.

CENTERING THE RUNNING BELT:

Place the treadmill on level ground and set it at 2MPH to check if the **Running Belt (No. C07)** drifts from the center.

If the **Running Belt (No. C07)** moves to the right, turn the right adjusting bolt $\frac{1}{4}$ turn *clockwise*, then turn the left adjustment bolt $\frac{1}{4}$ turn *counter-clockwise*. If the **Running Belt (No. C07)** does not move, repeat this step until it centers. Refer to Figure A.

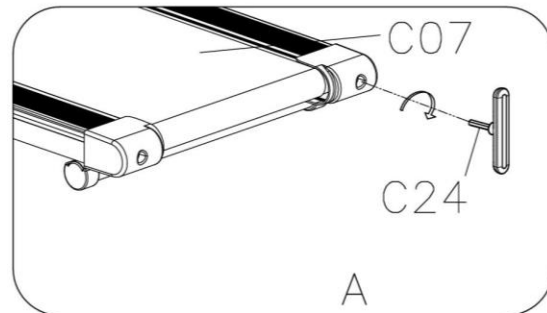

If the **Running Belt (No. C07)** moves to the left, turn the left adjusting bolt $\frac{1}{4}$ turn *clockwise*, then turn the right adjustment bolt $\frac{1}{4}$ turn *counter-clockwise*. If the **Running Belt (No. C07)** does not move, repeat this step until it centers. Refer to Figure B.

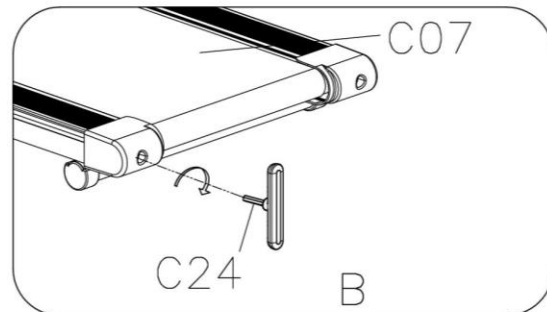

Over time, the **Running Belt (No. C07)** will loosen. To tighten the **Running Belt (No. C07)**, turn the left & right adjusting bolts one full turn *clockwise*, check the tension of the **Running Belt (No. C07)**. Continue this process until **Running Belt (No. C07)** is at the correct tension. Make sure to adjust both sides equally to ensure correct belt alignment. Refer to Figure C.

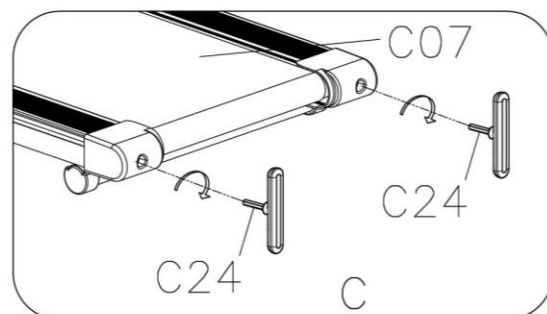

IMPORTANT ELECTRICAL INFORMATION

WARNING: This treadmill requires a power source of **8 amps (100-120V)** in order to properly operate. For your safety, as well as the safety of others, verify that the power source is correct before plugging in the equipment. Any power source above or below this level could cause significant damage to the equipment and/or user.

GROUNDING METHODS:

This product must be grounded. Grounding provides the least resistance for electrical current and will reduce the risk of electric shock. The plug must be plugged into an appropriate outlet that is properly installed and grounded in accordance with all local codes and ordinances. Ensure that the product is connected to an outlet which contains the same configuration as the plug. Do not use an adaptor for this product.

This product is for use on a nominal 100-120V circuit and has a grounding plug that looks like the plug illustrated in sketch A. Make sure that the product is connected to an outlet having the same configuration as the plug. No adaptor should be used with this product.

DANGER:

Improper connection of the equipment-grounding conductor can result in a risk of electrical shock. Check with a certified electrician if you are in doubt as to whether the product is properly grounded. Do not modify the plug provided with the product. If it will not fit the outlet, have a proper outlet installed by an electrician.

WARNING!

1. NEVER use a ground fault circuit interrupt (GFCI) wall outlet with this treadmill. Route the power cord away from any moving part of the treadmill including the elevation mechanism and transportation wheels.
2. NEVER operate the treadmill using a generator or UPS power supply.
3. NEVER remove any cover without first disconnecting AC power.
4. NEVER expose the treadmill to rain or moisture. This treadmill is not designed for use outdoors, near pools, or in any other high humidity environment.

GROUNDING METHOD

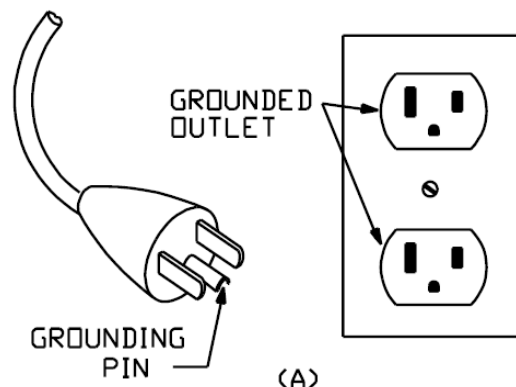

BATTERY INSTALLATION & REPLACEMENT

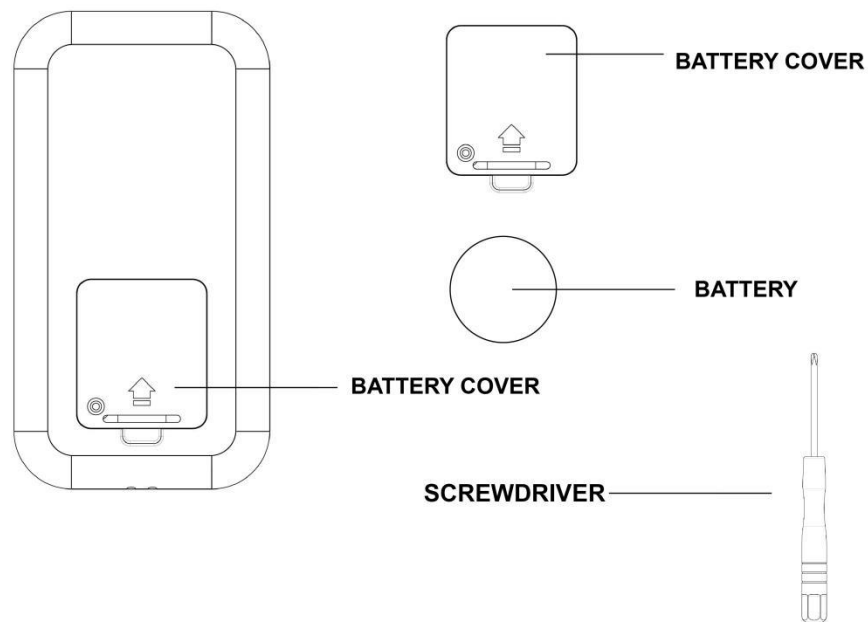

BATTERY INSTALLATION:

1. Use a **Screwdriver (No. H)** to loosen and remove the screw from the battery cover.
2. Take out the CR2032 battery that is included inside the remote control box.
3. Install the battery into the battery holder with the positive end facing up.
4. Put the battery cover back on to the battery holder and lock the screw into the battery cover.

BATTERY REPLACEMENT:

1. Use a **Screwdriver (No. H)** to loosen and remove the screw from the battery cover.
2. Remove the old battery and install the new battery into the battery holder with the positive pole facing up.
3. Put the battery cover back on to the battery holder and lock the screw into the battery cover.

Dispose of the old battery according to your regional guidelines.

Model: CR2301

Product Name: REMOTE CONTROL CR2301

FCC& IC Radiation Exposure Statement:

This equipment complies with FCC and Canada radiation exposure limits set forth for an uncontrolled environment.

This transmitter must not be co-located or operating in conjunction with any other antenna or transmitter.

THE DISPLAY CONSOLE

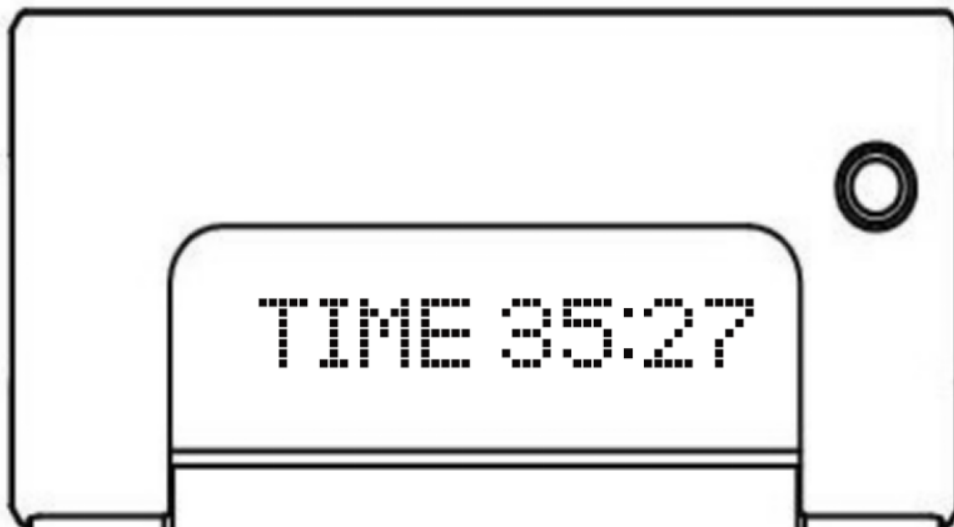

TIME 3:35 SPD 3.0 MILE 0.88 KCAL 20.8 STEP 00035

WINDOW DISPLAY:

Displays time, distance, calories, steps, and speed value in turn every 5 seconds.

REMOTE CONTROL FUNCTIONS:

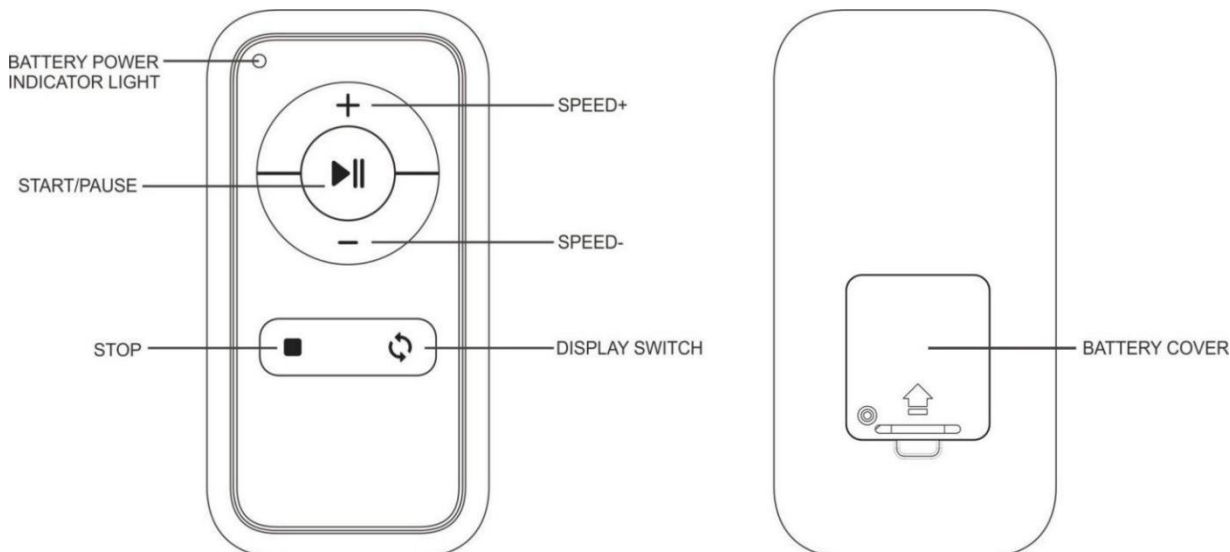

START/PAUSE: Press this button, so that treadmill begins running. 0.5 MPH is the default start speed. During exercise, you also can press this button to pause the machine.

SPEED +/-: Press the +/- buttons to increase or decrease the speed in increments of 0.1 MPH (Miles per hour). Pressing and holding either of these buttons for a duration of over ½ second will increase or decrease the speed continuously.

STOP: When in use, press the STOP button to terminate your workout session completely. All data will be deleted and reset to the initial setting.

DISPLAY SWITCH: When in use, you can press this button to switch the display between Time, Distance, Calories, Steps and Speed value.

BATTERY POWER INDICATOR LIGHT: When you press any button on the remote, the light will blink three times if the battery is low. Please proceed to change the battery. If it does not blink, then the battery is not low.

Note: If the treadmill does not respond to the remote control, you will need to resync the treadmill and remote control. Please take the following steps to resync:

1. Hold the remote right next to the screen the entire time while resyncing
2. Plug in the treadmill (do not turn it on)
3. Press and hold the start/pause button
4. While keeping the button pressed, turn on the treadmill
5. Continue to hold the button pressed for additional 5-10 seconds
6. Release the button and try to control the treadmill functions using the remote

WINDOW DISPLAY:

Displays calories, time, steps, distance, and speed value in turn every 5 seconds.

CALORIES: Displays the number of calories burned from 0.0 to 99999 KCAL. When the count reaches 99999 KCAL, it will reset and start back from 0.

TIME: Displays the time elapsed (0:00-99:59 MINS). If the time reaches 99:59, the treadmill will stop smoothly and display “End” then automatically reset to 0:00 after 5 seconds.

STEPS: Displays the number of steps from 0 to 99999. When the count reaches 99999, it will reset and start back from 0.

DISTANCE: Displays the distance traveled (0.00-99.99). When the distance reaches 99.99 MILE, it will reset to 0.00 and begin counting again from 0.00.

SPEED: When the handrails are down, the treadmill is in walking mode. The speed range is **0.5-3.7 MPH**. When the handrails are up, the treadmill is running mode. The speed range is **0.5-6.0 MPH**. 0.5MPH is the default running speed.

Note: When no person walks or runs on the machine, distance and calories will not count.

PROGRAMS	Initial	Default Value	Set Range	Display Range
TIME (MIN:SECOND)	0:00	N/A	N/A	0:00—99:59
SPEED (MPH)	0.0	0.5	0.5-3.7(WALKING) 0.5-6.0(RUNNING)	0.5-3.7(WALKING) 0.5-6.0(RUNNING)
DISTANCE (MILE)	0.00	N/A	N/A	0.00-99.99
STEP	0	N/A	N/A	0-99999
CALORIE (KCAL)	0.0	N/A	N/A	0.0-99999

LUBRICATION REMINDER:

Your treadmill needs lubrication maintenance every 188 miles. The system will release a beeping sound every 10 seconds and display an "OIL" icon on your display to remind you when it's time. Please read the LUBRICATING THE TREADMILL instructions on *Page 8* to learn the proper steps to lubricate your treadmill. Apply the lubricant to the middle of the running deck on both sides. After application, press and hold the STOP button for 3 seconds to clear the reminder.

POWER SAVE FUNCTION:

When the treadmill has been idle for 10 minutes, it will enter Power Saving Mode. While the treadmill is in this mode, the window display of the console will be turned off. To turn it back on, press any button.

Note: The machine will stop automatically after 15 minutes, if not in use.

I POWER ON:

Flick the power switch to this symbol to turn on the treadmill.

O POWER OFF:

Flick the power switch to this symbol to turn the treadmill off at any time. This includes during exercise.

EXERCISE INSTRUCTIONS

GETTING STARTED:

Before starting any exercise program, you should consult your physician to determine if you have any medical or physical conditions that could put your health and safety at risk or prevent you from using the equipment properly.

Be aware of your body's signals. Incorrect or excessive exercise can damage your health. Stop exercising immediately if you experience any of the following symptoms: pain, tightness in your chest, irregular heartbeat, shortness of breath, lightheadedness, dizziness, or feelings of nausea.

Get to know your treadmill. Before attempting to use the treadmill take some time to stand alongside and familiarize yourself with the controls.

1. Once you get on, you can stand with your feet on the **Side Rails (No. C06)** and stabilize yourself by holding onto the handrails.
2. Next, attach the pin end of the **Safety Key (No. E19)** to your clothes and insert the pin end of the **Safety Key (No. E19)** into the **Motor Top Cover (No. C01)**.
3. Press the START button to start the treadmill.
4. The treadmill will start at the system default setting speed of **0.5MPH**. When you feel comfortable, you may slowly increase this speed.
5. When you are finished with your exercise, press the STOP button to stop the treadmill or you can remove the pin end of the **Motor Top Cover (No. C01)** to stop the treadmill.

APP CONNECTION:

Connect Smart Equipment to SunnyFit App:

1. Scan to download SunnyFit from the app store:



2. Ensure that the Bluetooth function is turned on from your mobile device.
3. If this is your first time using the SunnyFit app, follow the in-app instructions to register for your free SunnyFit account and log in.
4. Begin any workout activity that matches your smart equipment, then follow the onscreen prompts to search for and connect to your smart equipment.
5. When connected, your stats and records will be displayed at the end of your course/session, and recorded in your account profile!

TROUBLESHOOTING

PROBLEM	POSSIBLE CAUSE	SUGGESTED ACTION
Treadmill will not start	Not plugged in.	Plug cord into outlet
	Safety Key not inserted.	Insert Safety Key
Running belt not centered	Running belt tension not correct on the left or right sides of the running board.	Tighten the adjustment bolts on the left and right side of the rear roller.
Console not working	Wires from the console and bottom control board are not properly connected.	Check wire connections from the console to the control board.
	Transformer is damaged.	If the transformer is damaged, contact customer service.
E01 ERROR: Message failure	Wires from the console and bottom control board are not properly connected.	Check wire connections from the console to the control board. If the wire has been punctured or damaged, you will need to replace it. If the problem is not rectified, you may need to replace the control board.
E02 ERROR: Burst clash protection	Incoming voltage is lower than 50% of the required voltage.	Check that the incoming power supply is the correct voltage.
E05 ERROR: Current overload protection (Self Protecting System)	The incoming voltage is too low or too high. The control board is damaged.	Restart the treadmill. Check the incoming voltage to ensure it is correct. Check the control board, replace if damaged.
	A moving part of the treadmill is stuck and therefore the motor is unable to rotate properly.	Inspect moving parts of the treadmill to ensure that they are operating correctly. Check the motor, listen for any strange noises and check for a burning smell. Replace the motor if necessary.

E06 ERROR: Motor abnormality	The motor wire is not connected, or the motor is damaged.	Check motor wires to see if the motor is connected. If the wire has been punctured or damaged, you will need to replace it. If the problem is not rectified, you may need to replace the motor.
E08 ERROR: Control board abnormality	The control board is not connected.	Check the upper and middle wires to see if the control board is connected. If the wire has been punctured or damaged, you will need to replace it. If the problem is not rectified, you may need to replace the control board.
E09 ERROR: Inversion error	The treadmill sets upright or not placed horizontally.	Adjust the treadmill and place it horizontally. If the wires of the control board are not connected well, replace with a new control board.
E10 ERROR: Motor abnormality	The motor is damaged, or a moving part of the treadmill is stuck and therefore the motor is unable to rotate properly.	Inspect moving parts of the treadmill to ensure that they are operating correctly. Replace the motor if necessary.

NOTE:

1. If you are having trouble connecting your smart equipment, visit www.sunnyfit.com/guide or scan the QR code below:



2. If you require additional support, please contact support@sunnyfit.com.

EXPLODED DIAGRAM

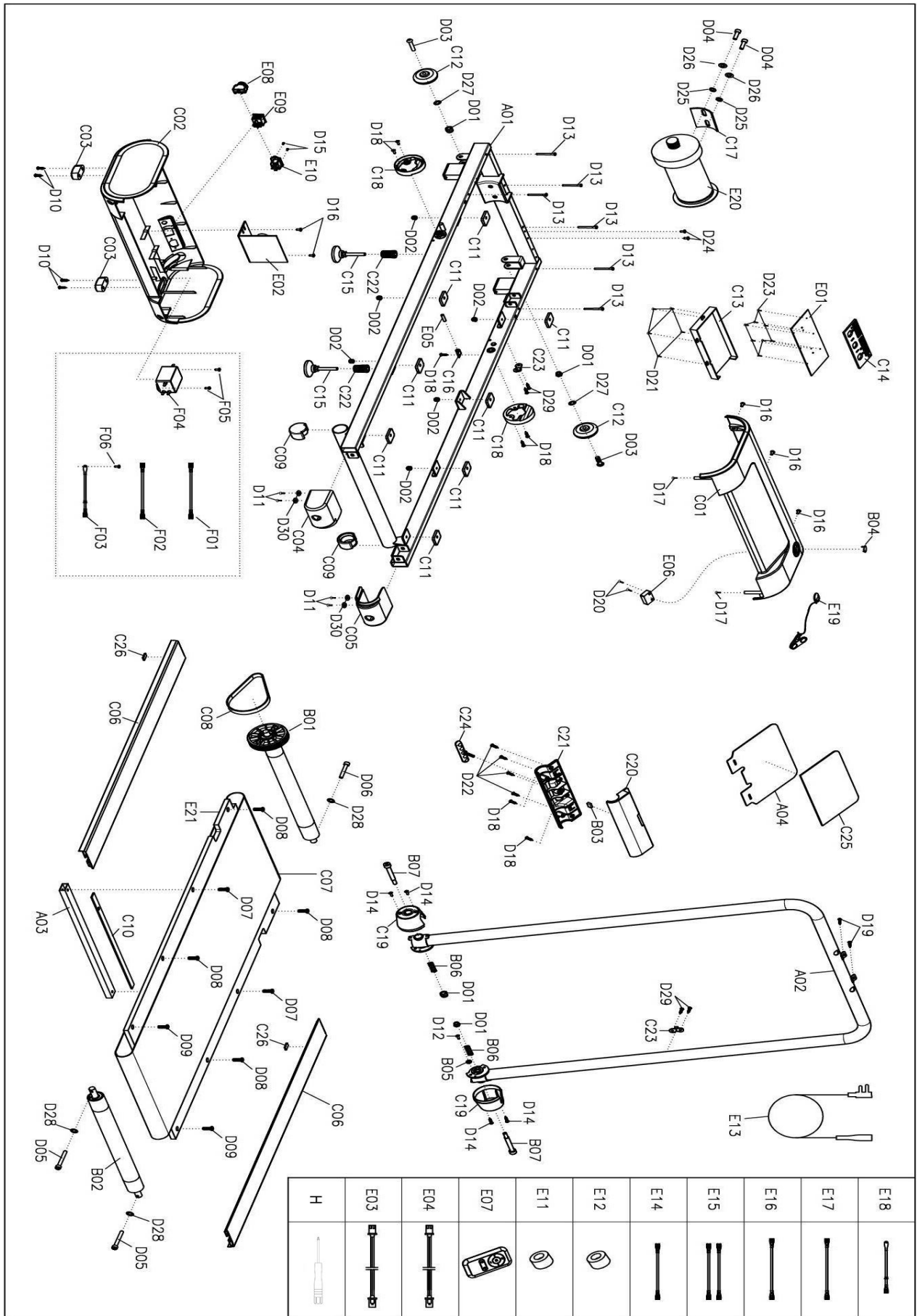

PARTS LIST

No.	Description	Spec.	Qty.	No.	Description	Spec.	Qty.
A01	Main Frame		1	D04	Bolt	M8*15	2
A02	Handlebar Tube		1	D05	Bolt	M6*55	2
A03	Running Board Strengthen Tube		1	D06	Bolt	M6*45	1
A04	Tablet Holder Base		1	D07	Bolt	M6*46	2
B01	Front Roller		1	D08	Bolt	M6*28	4
B02	Rear Roller		1	D09	Bolt	M6*25	2
B03	Magnet		1	D10	Bolt	M5*16	4
B04	Safety Key Plate		1	D11	Bolt	M5*12	4
B05	Round Magnet		1	D12	Bolt	M3*8	1
B06	Spring		2	D13	Screw	ST4.2*50	6
B07	Screw		2	D14	Bolt	M4*10	4
C01	Motor Top Cover		1	D15	Screw	ST2.9*8.0	2
C02	Motor Bottom Cover		1	D16	Screw	ST4.2*12	5
C03	Foot Pad		2	D17	Screw	ST4.2*20	2
C04	Left End Cap		1	D18	Screw	ST4.2*12	7
C05	Right End Cap		1	D19	Screw	ST4.2*10	2
C06	Side Rail		2	D20	Screw	ST2.9*8	2
C07	Running Belt		1	D21	Screw	ST2.9*6	5
C08	Motor Belt		1	D22	Screw	ST2.9*12	4
C09	C-shape Foot Pad		2	D23	Screw	ST2.5*6	8
C10	Rubber Pad		1	D24	Screw	ST4.2*12	2
C11	Rubber Cushion		8	D25	Spring Washer	Φ8	2
C12	Adjustable Wheel		2	D26	Flat Washer	Φ8	2
C13	Console Board Cover		1	D27	Locked Washer	Φ8	2
C14	Optical Grating		1	D28	Locked Washer	Φ6	3
C15	Adjustable Pad		2	D29	Screw	ST4.2*12	4
C16	Sensor Fixed Base		1	D30	Big Washer	Φ5*Φ15*1	4
C17	Eva Pad		1	E01	Console		1
C18	Bottom Inner Cover		2	E02	Control Board		1
C19	Bottom Outer Cover		2	E03	Console Communication Wire		1
C20	Tablet Holder Top Cover		1	E04	Console Connecting Wire		1
C21	Tablet Holder Bottom Cover		1	E05	Magnetic Sensor		1
C22	Foot Pad Sleeve		2	E06	Safety Key Magnetic Sensor		1
C23	Lead Wire Buckle		2	E07	Remote Control		1
C24	T-shape Wrench	5#	1	E08	Overload Protector		1
C25	Eva Pad		1	E09	Square Switch		1
C26	Rubber Blanket		1	E10	Power Socket		1
D01	Nut	M8	4	E11	Magnet Ring		1
D02	Nut	M6	6	E12	Magnet Core		1
D03	Bolt	M8*40	2	E13	Power Cord		1

No.	Description	Spec.	Qty.
E14	AC Single Line	L200 Blue	1
E15	AC Single Line	L200 Brown	2
E16	AC Single Line	L350 Brown	1
E17	AC Single Line	L350 Blue	1
E18	AC Single Line	L350 Yellow	1
E19	Safety Key		1
E20	Motor		1
E21	Running Board		1

No.	Description	Spec.	Qty.
F01	AC Single Line	Brown	1
F02	AC Single Line	Blue	1
F03	Grounding Wire	Green and Yellow	1
F04	Filter		1
F05	Screw	ST4.2*12	2
F06	Screw	ST4.2*12	1
H	Screwdriver		1

Version 2.2

CONNECT
With us

DOWNLOAD

Track your fitness progress & join
FREE workout courses!

Download  **SUNNYFIT** today!



FOLLOW

Find us on social media @sunnyhealthfitness

 @sunnyhealthfitness

 @sunnyhealthandfitness

 @sunnyhealthfit

 /sunnyhealthfitness

 /sunnyhealthfitness

 /sunnyhealthandfitness

www.sunnyhealthfitness.com