

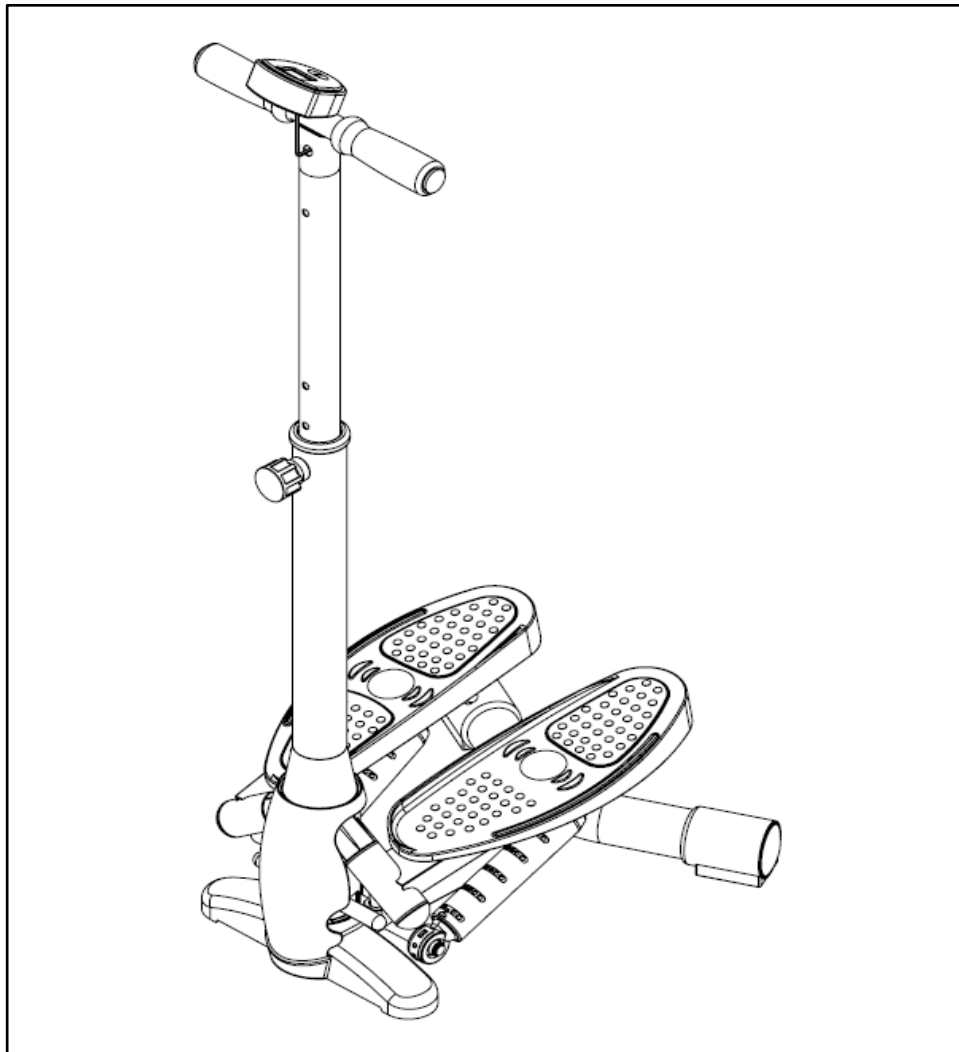

TWIST-IN STEPPER WITH HANDLEBAR

SF-S0637

USER MANUAL



IMPORTANT! Please retain owner's manual for maintenance and adjustment instructions. Your satisfaction is very important to us, **PLEASE DO NOT RETURN UNTIL YOU HAVE CONTACTED US:** support@sunnyhealthfitness.com or 1- 877 - 90SUNNY (877-907-8669).

IMPORTANT SAFETY INFORMATION

We thank you for choosing our product. To ensure your safety and health, please use this equipment correctly. It is important to read this entire manual before assembling and using the equipment. Safe and effective use can only be achieved if the equipment is assembled, maintained and used properly. It is your responsibility to ensure that all users of the equipment are informed of all warnings and precautions.

1. Before starting any exercise program, you should consult your physician to determine if you have any medical or physical conditions that could put your health and safety at risk or prevent you from using the equipment properly. Your physician's advice is essential if you are taking medication that affects your heart rate, blood pressure or cholesterol level.
2. Be aware of your body's signals. Incorrect or excessive exercise can damage your health. Stop exercising if you experience any of the following symptoms: pain, tightness in your chest, irregular heartbeat, shortness of breath, lightheadedness, dizziness or nauseous feeling. If you do experience any of these conditions, you should consult your physician before continuing with your exercise program.
3. Keep children and pets away from the equipment. The equipment is designed for adult use only.
4. Use the equipment on a solid, flat level surface with a protective cover for your floor or carpet. To ensure safety, the equipment should have at least 4 feet (1.2 m) of free space all around it.
5. Ensure that all nuts and bolts are securely tightened before using the equipment. The safety of the equipment can only be maintained if it is regularly examined for damage and/or wear and tear.
6. Always use the equipment as indicated. If you find any defective components while assembling or checking the equipment, or if you hear any unusual noises coming from the equipment during exercise, discontinue use of the equipment immediately and do not use until the problem has been rectified.
7. Wear suitable clothing while using the equipment. Avoid wearing loose clothing that may become entangled in the equipment.
8. Do not place fingers or objects into the moving parts of the equipment.
9. The maximum weight capacity of this unit is 220 pounds (100 kg).
10. The equipment is not suitable for therapeutic use.
11. To avoid bodily injury and/ or damage to the product or property, proper lifting and moving are required.
12. Your product is intended for use in cool and dry conditions. You should avoid storage in extreme cold, hot or damp areas as this may lead to corrosion and other related problems.
13. This equipment is designed for indoor and home use only; it is not intended for commercial use.

NOTE:

We recommend that you place a non-slip mat underneath the stepper to protect your carpet or floor.

Always make sure that the product is placed on a flat and non-skid surface.

Check all connections and moving parts on a regular basis. Damaged parts have to be changed immediately. During the time of repair the product must not be used by anybody.

Clean your equipment with non-caustic detergents. Use a soft cloth for drying after cleaning.



A) This product has been tested in accordance with the requirements of EN 957-1, 957-8 standard, class H (home use). The maximum load is limited to 100 kg.

B) The CE marking of this item is in regard to the electromagnetic compatibility (EC-directive 89/EWG) as well as to the electrical safety.

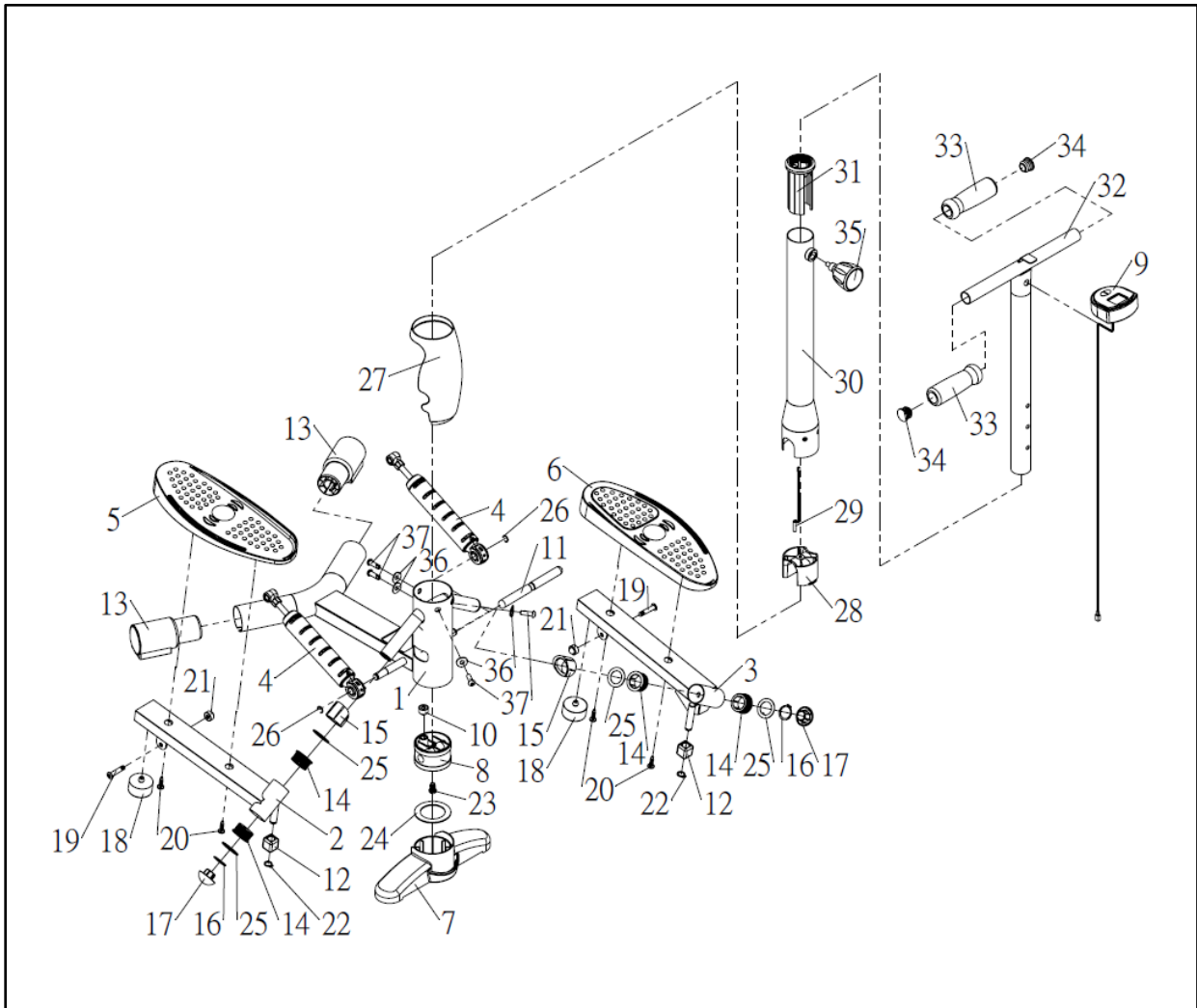
EXPLODED DIAGRAM

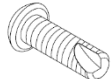

HARDWARE PACKAGE

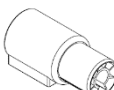
	_____	1 PCS		_____	#37 M8 x 24.5 4 PCS
	_____	#36 4 PCS		_____	# 27 1 PCS
	_____	#13 2 PCS			

PARTS LIST

NO.	DESCRIPTION	SPECIFICATION	QTY
1	Main Frame		1
2	Pedal Holder, Right		1
3	Pedal Holder, Left		1
4	Hydraulic Cylinder		2
5	Pedal, Right		1
6	Pedal, Left		1
7	Front Base Support		1
8	Plastic Spacer		1
9	Meter		1
10	Magnet		1
11	Axle	16x170 mm	1
12	Square Plastic Bushing	25.4 mm	2
13	Plastic End Piece		2
14	Plastic Bushing	38 mm	4
15	Plastic Spacer		2
16	C-Ring		2
17	Plastic Cap		2
18	Pedal Stopper		2
19	Screw	M8 x 40 mm	2
20	Screw	M6 x 23 mm	4
21	Nut	M8	2
22	C-Ring		2
23	Screw	M8 x 20 mm	1
24	Washer	72 mm	1
25	Washer	38 mm	4
26	E-Ring		2
27	Cover		1
28	Plastic Bracket		1
29	Wire A		1
30	Handle Tube A		1
31	Plastic Bushing		1
32	Handlebar		1
33	Foam Grip		2
34	Round Plug		2
35	Knob		1
36	Washer		4
37	Screw	M8 x 24.5	4

Ordering Replacement Parts (U.S. and Canadian Customers only)

Please provide the following information in order for us to accurately identify the part(s) needed:

- ✓ The model number (found on cover of manual)
- ✓ The product name (found on cover of manual)
- ✓ The part number found on the “EXPLODED DIAGRAM” and “PARTS LIST” (found near the front of the manual)

Please contact us at support@sunnyhealthfitness.com or 1-877- 90SUNNY (877-907-8669).

ASSEMBLY INSTRUCTIONS

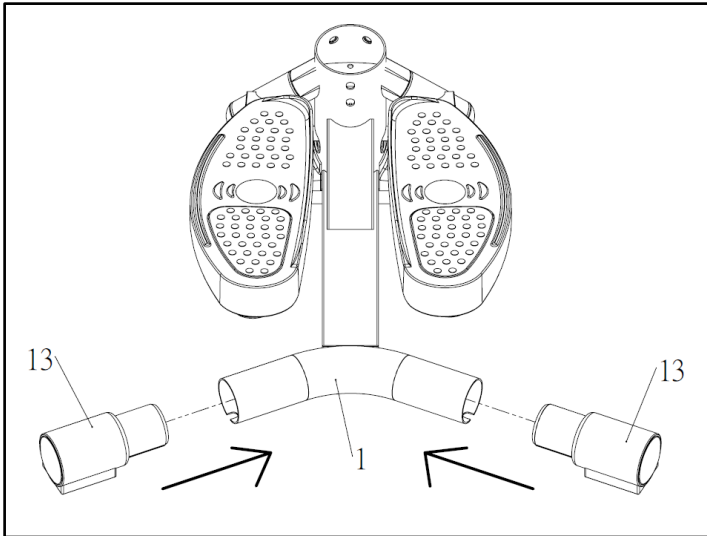

STEP 1:

Put the 2 **Plastic End Pieces (No. 13)** onto the rear tubes on the **Main Frame (No. 1)**. Make sure the ball pins pop into the holes on the bottom of the rear tubes.

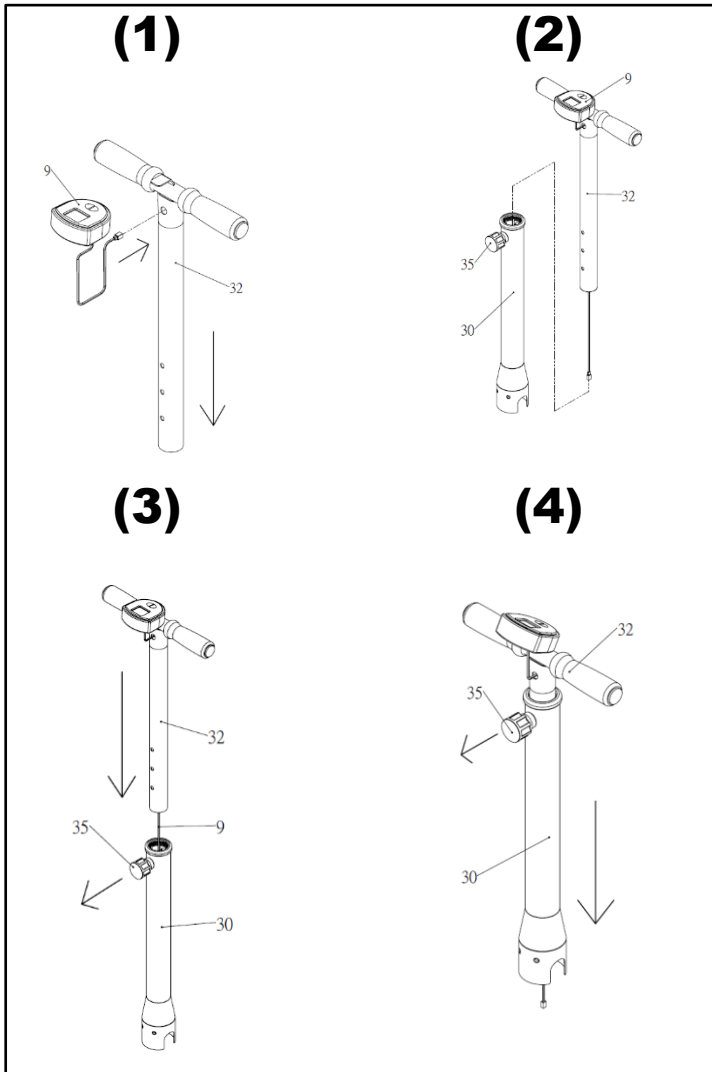

STEP 2:

(1) Insert the meter wire into the hole at the top of the **Handlebar (No. 32)**.
(No. 32).

(2) Thread the meter wire through the **Handlebar (No. 32)** post. Insert the **Meter (No. 9)** onto the **Handlebar (No. 32)**.

(3) Pull the **Knob (No. 35)** and lower the **Handlebar (No. 32)** post and the meter wire into **Handlebar Tube A (No. 30)**.

(4) Set at desired height. Release the **Knob (No. 35)** and make sure the pin pops into one of the holes on the **Handlebar (No. 32)** post.

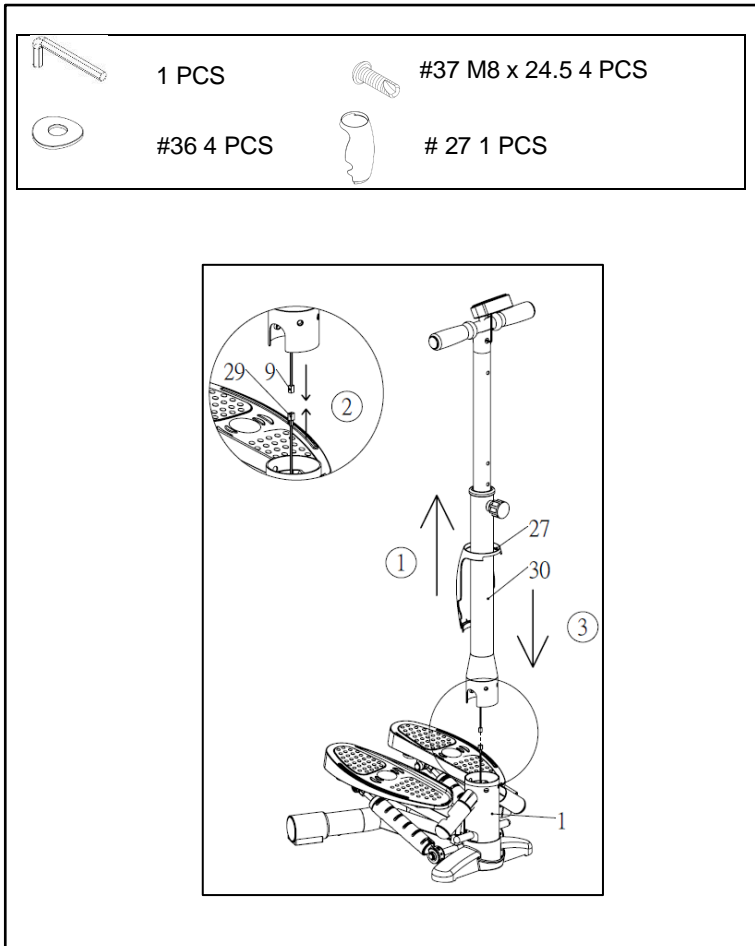

STEP 3:

(1) Pull the **Cover (No. 27)** up.

(2) Connect the meter wire to the **Wire A (No. 29)** in the **Main Frame (No. 1)**.

(3) Lower the **Handlebar Tube (No. 30)** into the **Main Frame (No. 1)**.

(4) Secure with **4 Washers (No. 36)** and **4 Screws (No. 37)**.

(5) Rotate the **Cover (No. 27)** and lower it, so the bottom of the **Cover (No. 27)** inserts into the slot on the **Front Base Support (No. 7)**.

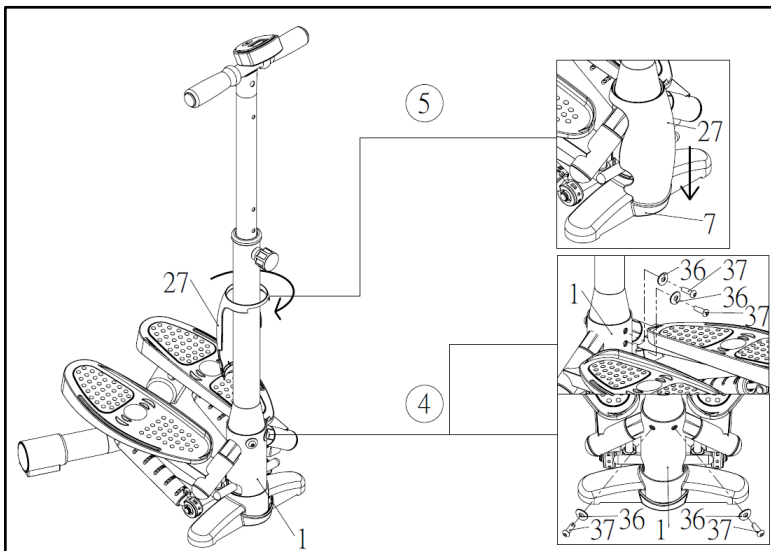

The assembly is complete!

BATTERY:

Prior to first use of the product you have to install the battery. If the display is not working properly, change the battery.

To change the battery, remove the meter from the handlebar. The battery compartment is located at the back of the meter. After you change the battery, put the meter back on the handlebar. Dispose of old battery according to your State and Regional guidelines.

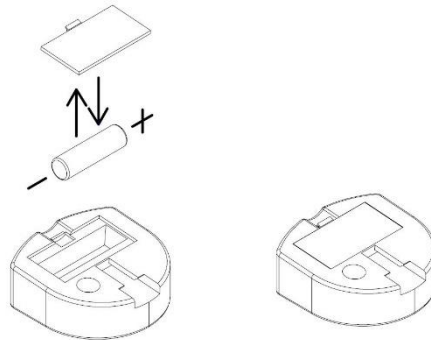

METER INSTRUCTIONS

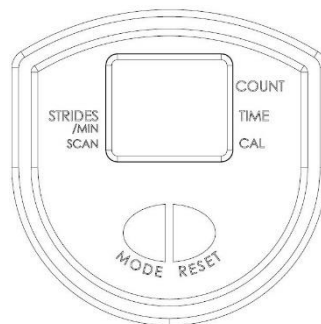

MODE Press to select each function.

RESET Press and hold for 3 seconds to reset all values.

SCAN Automatically displays each function in sequence for a few seconds each.

TIME Counts from 00:00 up to 99:59 in one-second increments.

CALORIES Accumulates the calorie consumption during your exercise. This is a rough guide and should only be used as a comparison figure over several exercise sessions.

COUNT Accumulates the numbers of strides during a work-out session.
Meter counts 1 stride after you step once with each foot.

STRIDES/MIN Displays strides per minute.

1. To turn on the meter, press any button or start exercise.
2. After 4 minutes of inactivity, the meter will shut off automatically.