

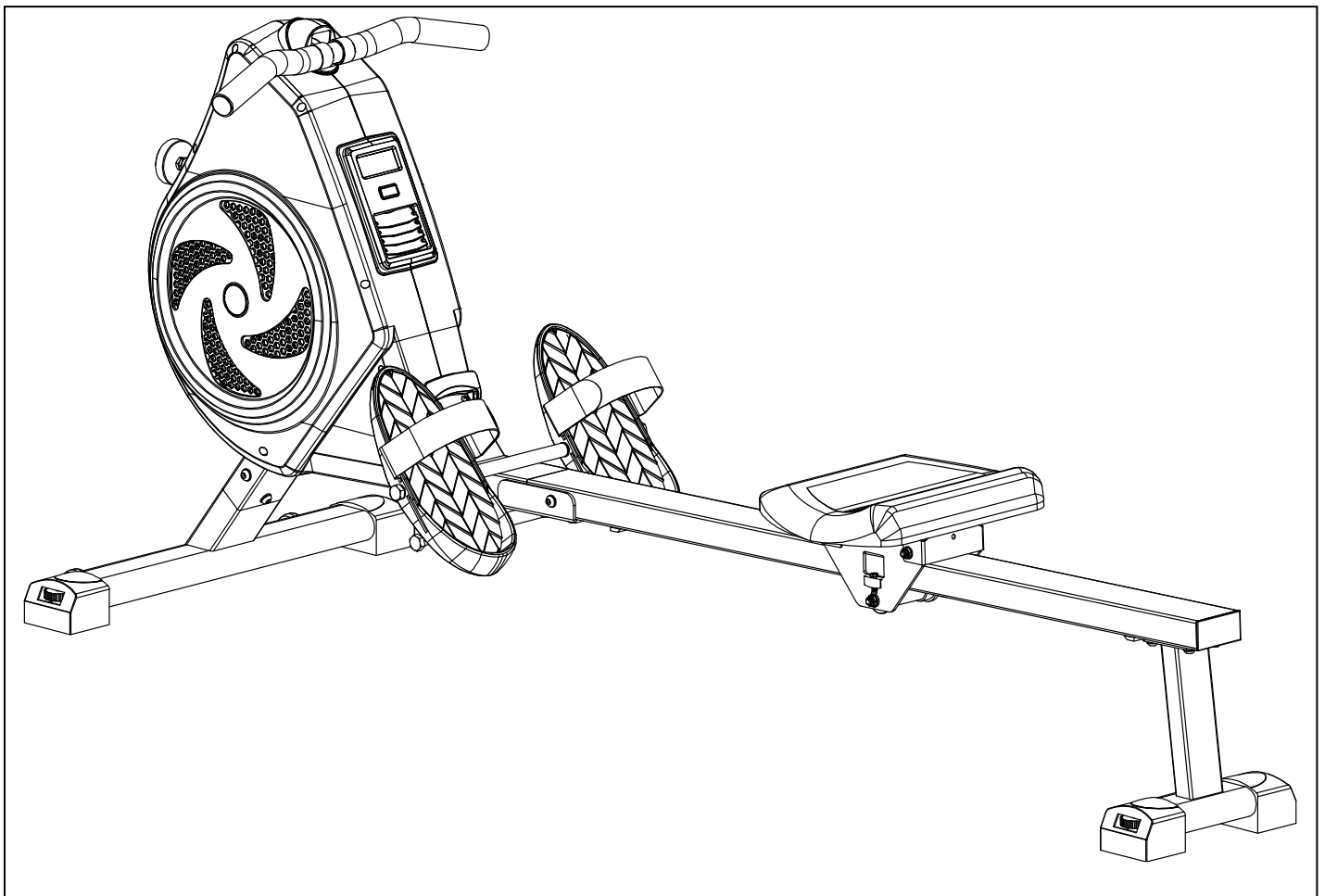

AIR ROWING MACHINE

SF-RW520007

USER MANUAL



IMPORTANT! Please retain owner's manual for maintenance and adjustment instructions. Your satisfaction is very important to us, **PLEASE DO NOT RETURN UNTIL YOU HAVE CONTACTED US:** support@sunnyhealthfitness.com or 1-877-90SUNNY (877-907-8669).



WWW.SUNNYHEALTHFITNESS.COM

IMPORTANT SAFETY INFORMATION

We thank you for choosing our product. To ensure your safety and health, please use this equipment correctly. It is important to read this entire manual before assembling and using the equipment. Safe and effective use can only be achieved if the equipment is assembled, maintained, and used properly. It is your responsibility to ensure that all users of the equipment are informed of all warnings and precautions.

1. Before starting any exercise program, you should consult your physician to determine if you have any medical or physical conditions that could put your health and safety at risk or prevent you from using the equipment properly. Your physician's advice is essential if you are taking medication that affects your heart rate, blood pressure, or cholesterol level.
2. Be aware of your body's signals. Incorrect or excessive exercise can damage your health. Stop exercising if you experience any of the following symptoms: pain, tightness in your chest, irregular heartbeat, shortness of breath, lightheadedness, dizziness, or feelings of nausea. If you do experience any of these conditions, you should consult your physician before continuing with your exercise program.
3. Keep children and pets away from the equipment. The equipment is designed for adult use only.
4. Use the equipment on a solid, flat level surface with a protective cover for your floor or carpet. To ensure safety, the equipment should have at least 2 feet (60 CM) of free space all around it.
5. Ensure that all nuts and bolts are securely tightened before using the equipment. The safety of the equipment can only be maintained if it is regularly examined for damage and/or wear and tear.
6. Always use the equipment as indicated. If you find any defective components while assembling or checking the equipment, or if you hear any unusual noises coming from the equipment during exercise, discontinue use of the equipment immediately and do not use until the problem has been rectified.
7. Wear suitable clothing while using the equipment. Avoid wearing loose clothing that may become entangled in the equipment.
8. Do not place fingers or objects into the moving parts of the equipment.
9. The maximum weight capacity of this unit is 300 pounds (135 KG).
10. The equipment is not suitable for therapeutic use.
11. To avoid bodily injury and/or damage to the product or property, proper lifting and moving are required.
12. Your product is intended for use in cool and dry conditions. You should avoid storage in extreme cold, hot or damp areas as this may lead to corrosion and other related problems.
13. This equipment is designed for indoor and home use only; it is not intended for commercial use.

IMPORTANT NOTE: Please remove the plastic tab from the computer before use!



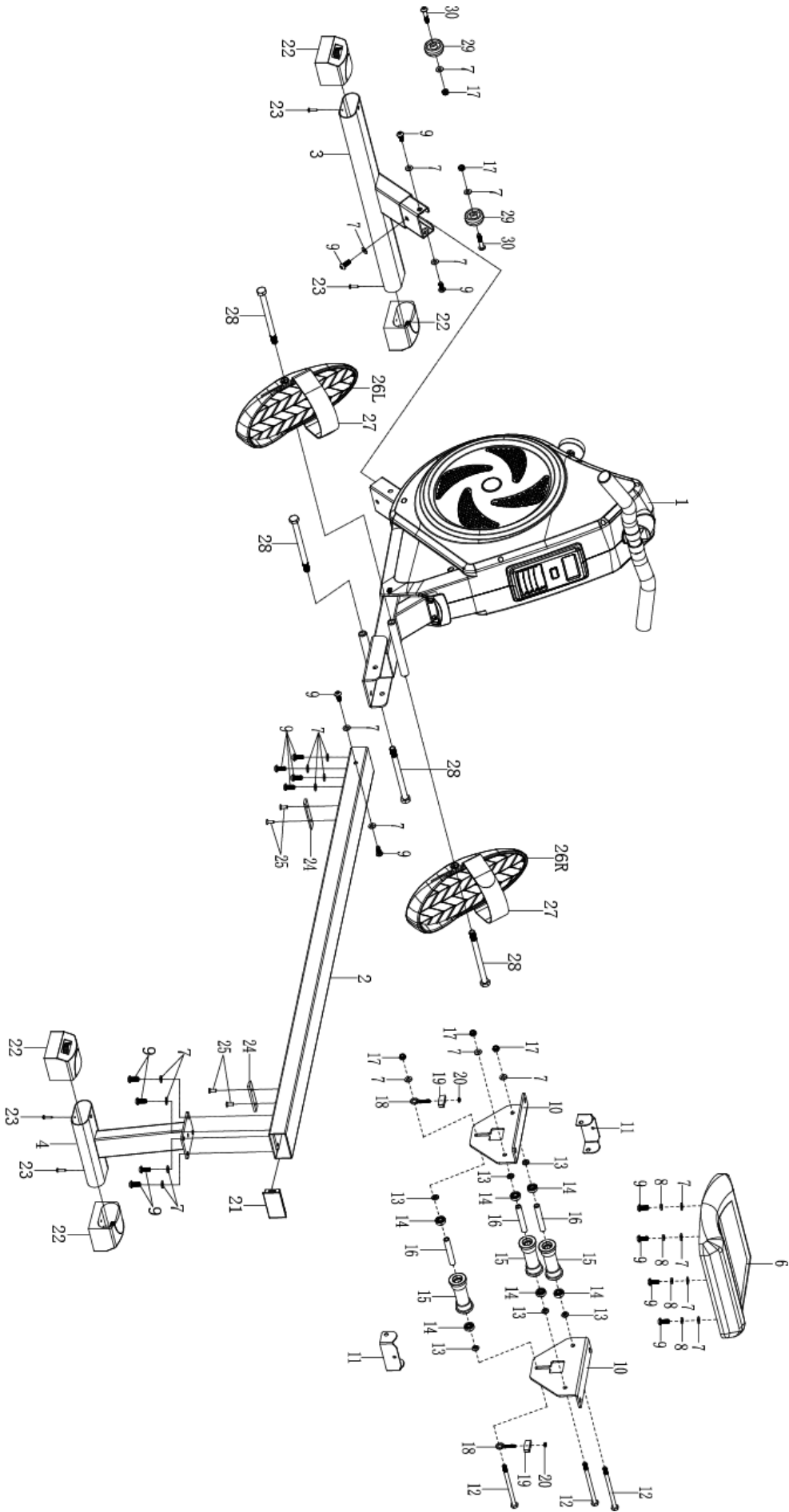

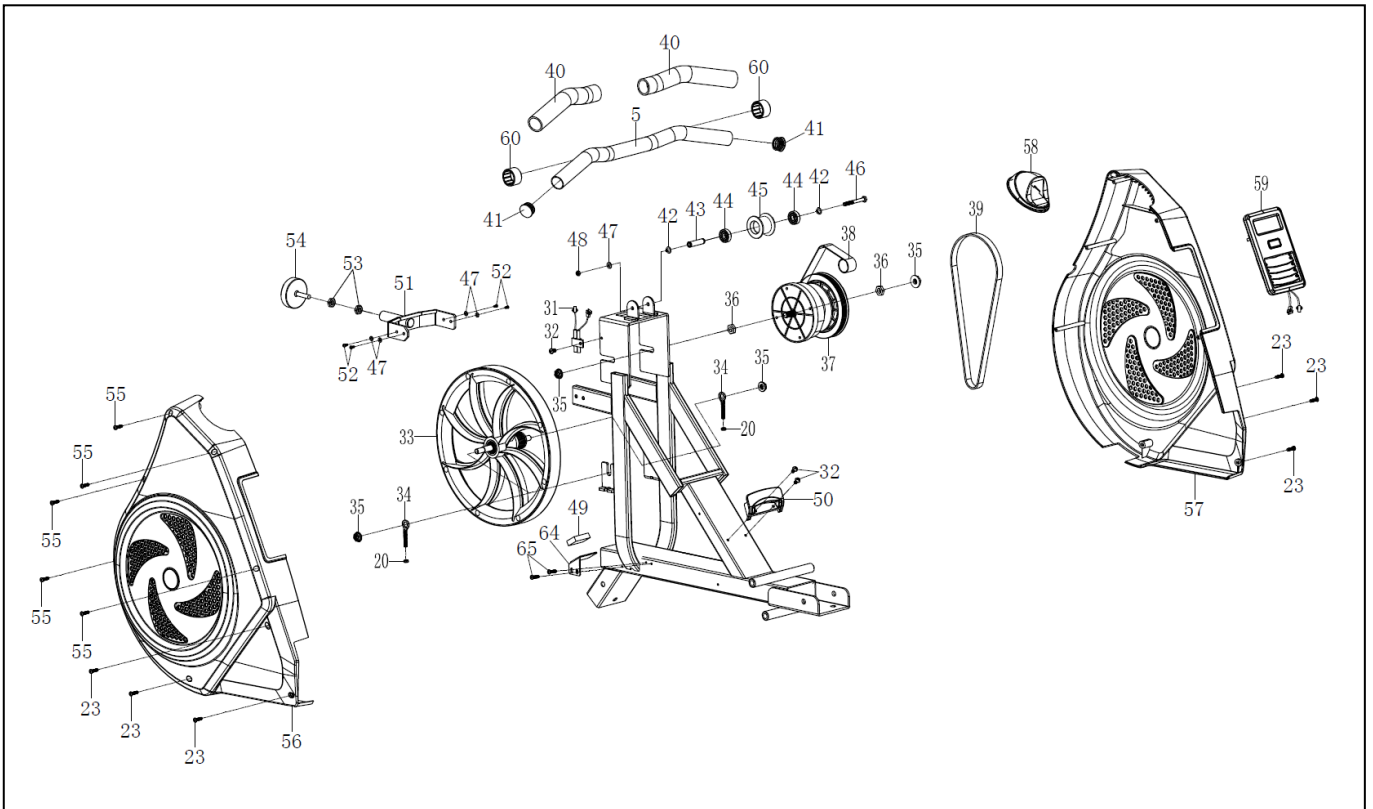

EXPLODED DIAGRAM 1

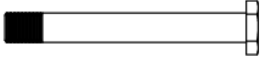

EXPLODED DIAGRAM 2

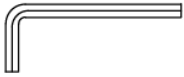

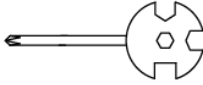
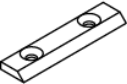
HARDWARE PACKAGE

	#9 M8*20 13PCS		#28 M12*160 4PCS
	#7 Φ8*Φ16*1.5 13PCS		#61 S6 1PC
	#25 M6*15 2PCS		#62 S10,13,14,15 1PC
	#24 75*18*5 1PC		#63 S10,13,17,19 1PC

PARTS LIST

No.	Description	Spec.	Qty
1	Main Frame		1
2	Sliding Rail		1
3	Front Stabilizer		1
4	Rear Stabilizer		1
5	Handlebar		1
6	Seat		1
7	Washer	Φ8*Φ16*1.5	22
8	Spring Washer	Φ8	4
9	Bolt	M8*20	17
10	Seat Supporting Board		2
11	Seat Junction Bracket		2
12	Bolt	M8*125	3
13	Spacer	Φ15*Φ8*4	6
14	Bearing	608	6
15	Wheel	Φ39*92	3
16	Plastic Casing Pipe	Φ12*Φ9*78	3
17	Nut	M8	5
18	Adjusting Bolt	M6*36	2
19	U Bracket		2
20	Nut	M6	4
21	Cap	80*40*2.0	1
22	End Cap		4
23	Screw	ST4.2*20	10
24	Limit Pad	75*18*5	2
25	Screw	M6*15	4
26L/R	Pedal		2
27	Pedal Strap		2
28	Bolt	M12*160	4
29	Transportation Wheel	Φ42*22*Φ8.2	2
30	Bolt	M8*40	2
31	Sensor Wire	L=400	1
32	Bolt	M5*10	3
33	Fan Wheel		1

No.	Description	Spec.	Qty
34	Adjusting Bolt	M6*45	2
35	Nut	M10*1.0*9	4
36	Nut	M10*1	2
37	Belt Wheel		1
38	Mesh Belt		1
39	Belt	PJ280	1
40	Handrail Foam Grip	Φ27*Φ33*224	2
41	Cap		2
42	Shaft Ring	Φ10*1.0	2
43	Slide Shaft	Φ10*40	1
44	Bearing	6000	2
45	Pulley	Φ45*35	1
46	Bolt	M6*55	1
47	Washer	Φ6*Φ12*1.0	5
48	Nut	M6	1
49	Magnet	40*25*10	1
50	Tablet Bracket		1
51	Foot Pad Tube		1
52	Bolt	M6*12	4
53	Nut	M8	2
54	Foot Pad	M8*30	1
55	Screw	ST4.2*25	5
56	Left Cover		1
57	Right Cover		1
58	Handle Guide		1
59	Computer		1
60	Limit Sleeve		2
61	Allen Wrench	S6	1
62	Spanner	S10,13,14,15	1
63	Spanner	S10,13,17,19	1
64	Magnetic Plate	80*48.6*2.0	1
65	Screw	4.8*20	2

Ordering Replacement Parts (U.S. and Canadian Customers only)

Please provide the following information in order for us to accurately identify the part(s) needed:

- ✓ The model number (found on cover of manual)
- ✓ The product name (found on cover of manual)
- ✓ The part number found on the “EXPLODED DIAGRAM” and “PARTS LIST” (found near the front of the manual)

Please contact us at support@sunnyhealthfitness.com or 1-877-90SUNNY (877-907-8669).

ASSEMBLY INSTRUCTIONS

We value your experience using Sunny Health and Fitness products. For assistance with parts or troubleshooting, please contact us at support@sunnyhealthfitness.com or 1-877-90SUNNY (877-907-8669).

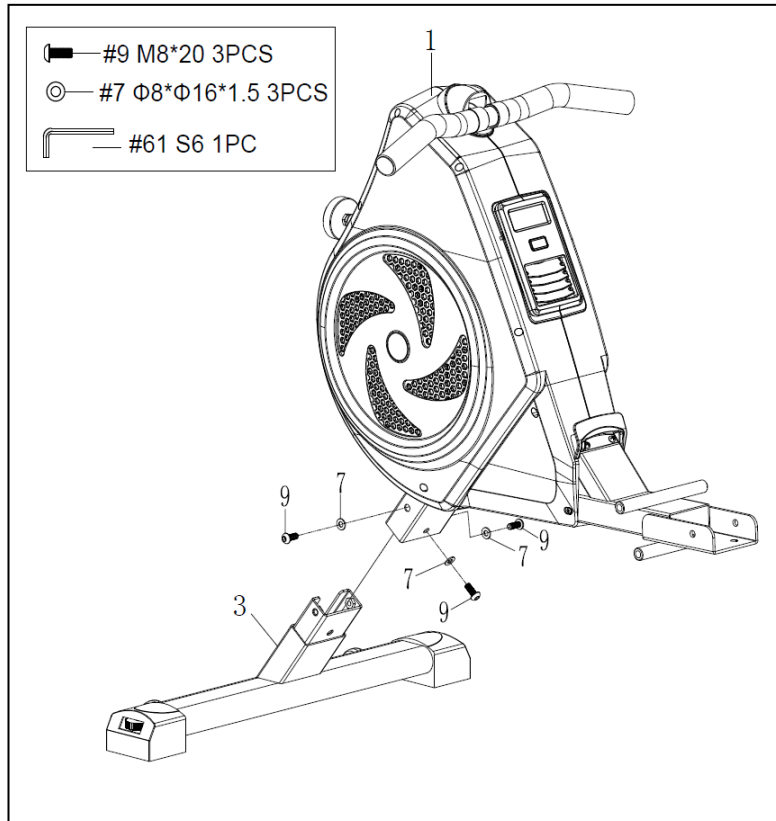

STEP 1:

Attach the **Front Stabilizer (No. 3)** to the **Main Frame (No. 1)** using 3 **Bolts (No. 9)** and 3 **Washers (No. 7)**. Tighten and secure with **Allen Wrench (No. 61)**.

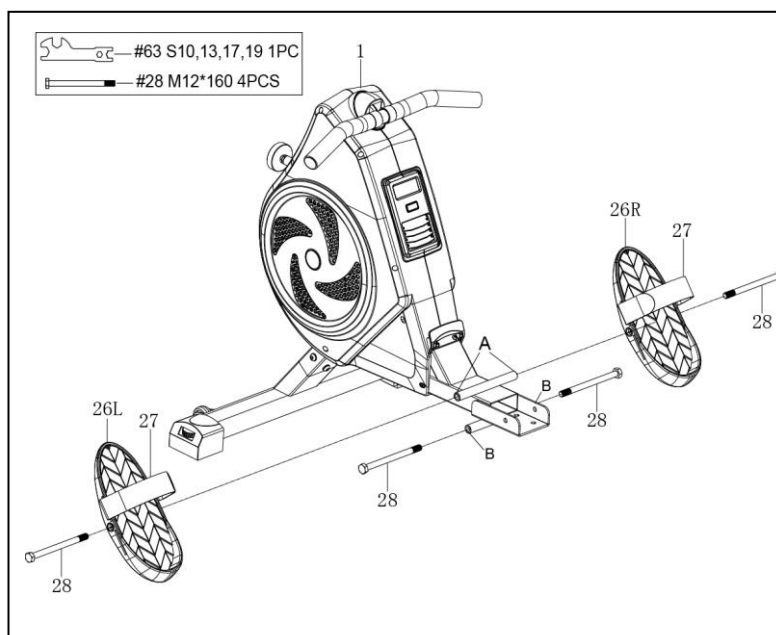

STEP 2:

Insert 2 **Bolts (No. 28)** through the **Left & Right Pedals (No. 26L/R)** into the upper hole at position **A** of the **Main Frame (No. 1)**. Tighten with **Spanner (No. 63)**.

Insert 2 **Bolts (No. 28)** into the bottom hole at position **B** of the **Main Frame (No. 1)**. Tighten with **Spanner (No. 63)**.

NOTE: The **Left & Right Pedals (No. 26L/R)** should rest on the bottom **Bolts (No. 28)** at position **B**.

We value your experience using Sunny Health and Fitness products. For assistance with parts or troubleshooting, please contact us at support@sunnyhealthfitness.com or 1-877-90SUNNY (877-907-8669).

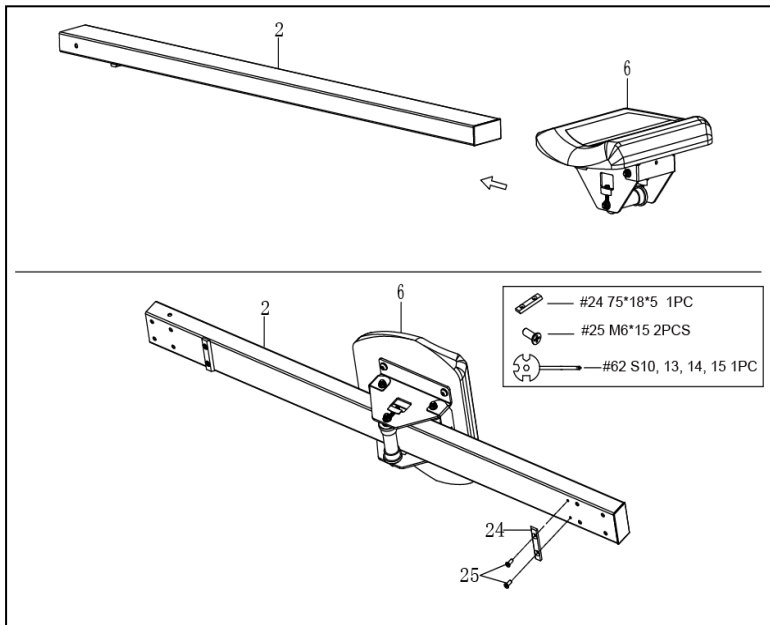

STEP 3:

Slide the **Seat (No. 6)** into the **Sliding Rail (No. 2)**.

Attach 1 **Limit Pad (No. 24)** onto the **Sliding Rail (No. 2)** using 2 **Screws (No. 25)**, then tighten with **Spanner (No. 62)**.

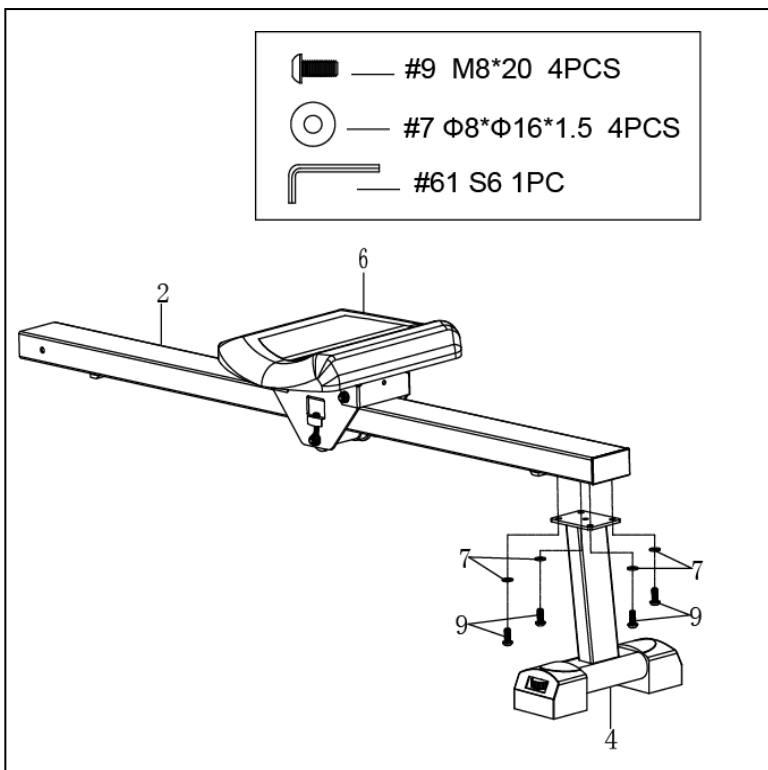

STEP 4:

Attach the **Rear Stabilizer (No. 4)** to the **Sliding Rail (No. 2)** using 4 **Bolts (No. 9)** and 4 **Washers (No. 7)**. Tighten and secure with **Allen Wrench (No. 61)**.

We value your experience using Sunny Health and Fitness products. For assistance with parts or troubleshooting, please contact us at support@sunnyhealthfitness.com or 1-877-90SUNNY (877-907-8669).

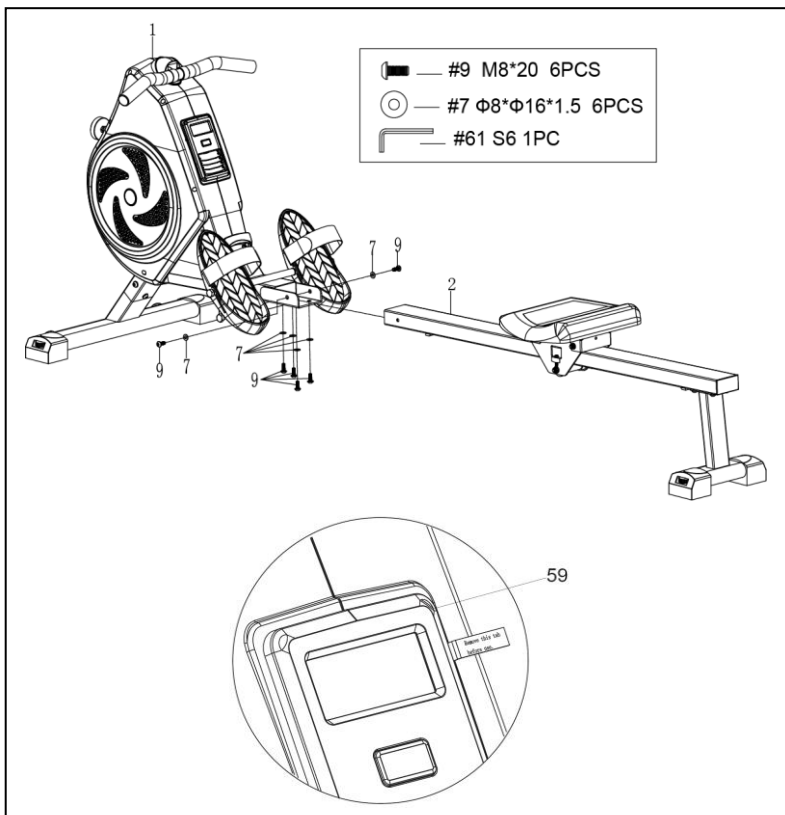

STEP 5:

Attach the **Sliding Rail (No. 2)** to the **Main Frame (No. 1)** by securing 2 **Bolts (No. 9)** and 2 **Washers (No. 7)** onto the left and right sides of the **Main Frame (No. 1)**. Don't tighten the **Bolts (No. 9)** now.

Secure 4 **Bolts (No. 9)** and 4 **Washers (No. 7)** to the bottom of the **Main Frame (No. 1)**. Tighten all the 6 **Bolts (No. 9)** with **Allen Wrench (No. 61)** now.

IMPORTANT NOTE: Please remove the plastic tab from the computer before use! If computer doesn't work after removing the plastic tab, please press the buckles on one side of the **Computer (No. 59)** to remove the **Computer (No. 59)** from **Main Frame (No. 1)** and check if the batteries are well installed.

The assembly is complete!

ADJUSTMENTS & USAGE GUIDE

CAUTION! Moving parts, such as the seat, can cut and crush. Keep hands clear of the sliding rail during use!

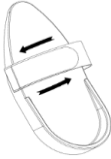
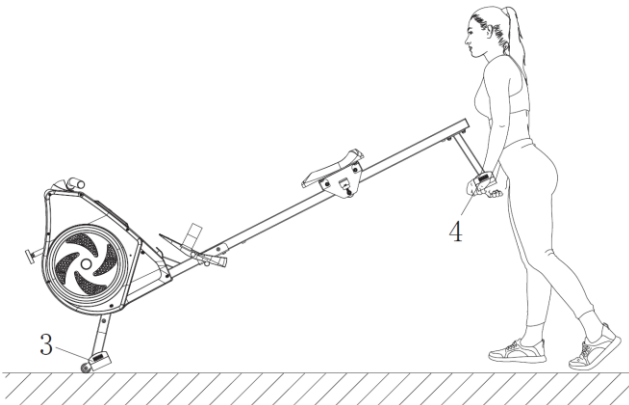
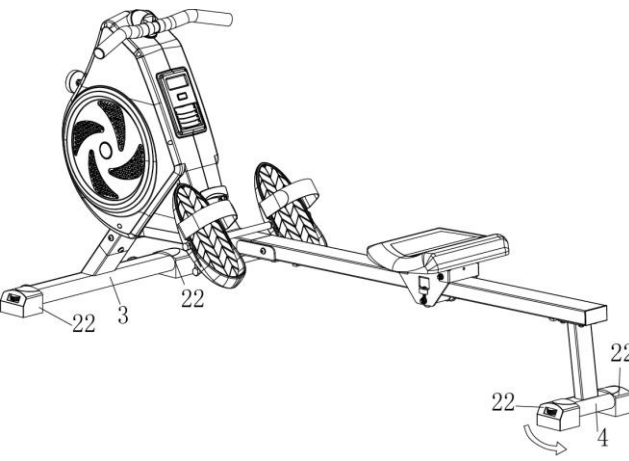
	<p>PEDAL STRAP ADJUSTMENT</p> <p>The pedal strap is adjustable and can be personalized to fit the user's foot size.</p>
	<p>MOVING THE ROWER</p> <p>To move the rower, lift the Rear Stabilizer (No. 4) up until the transportation wheels on the Front Stabilizer (No. 3) touch the ground. With the transportation wheels on the ground, you can transport the rower to the desired location with ease.</p>
	<p>ADJUSTING THE BALANCE</p> <p>Adjust the End Caps (No. 22) on the Rear Stabilizer (No. 4) and Front Stabilizer (No. 3) of the rower if the rower is unbalanced during use.</p>

BATTERY REPLACEMENT

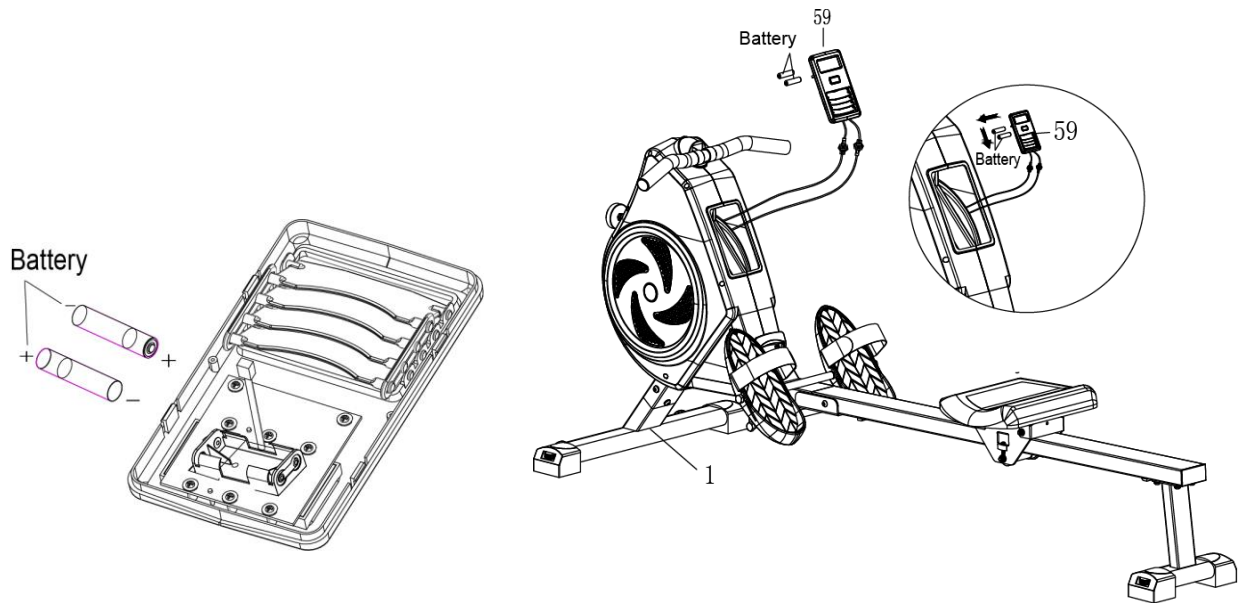

1. Press the buckles on one side of the **Computer (No. 59)** to remove the **Computer (No. 59)** from **Main Frame (No. 1)**.
2. Take out the 2pcs old AAA batteries from the battery case and install 2pcs new AAA batteries into the battery case on the back of the **Computer (No. 59)**. Pay attention to the battery + and – poles before installing.
3. Insert the buckles on one side of the **Computer (No. 59)** into the computer slot. Then insert the buckles on the other side of the **Computer (No. 59)**, and press **Computer (No. 59)** down in the computer slot.

The replacement is complete!

NOTE: Always change both batteries at the same time. Do not mix battery types and do not mix old and new batteries. Dispose batteries according to your state and regional guidelines.

STORAGE GUIDE

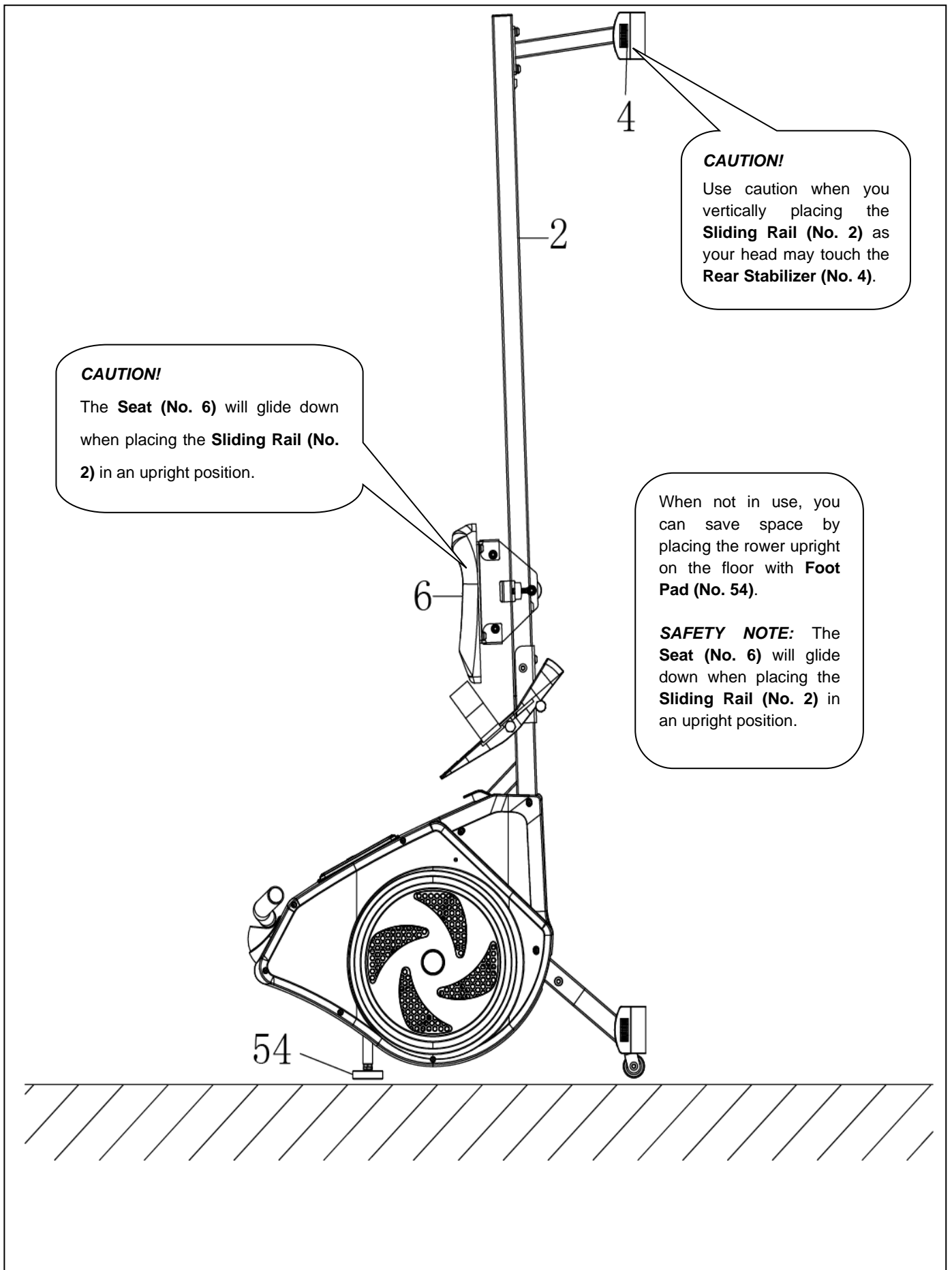

EXERCISE COMPUTER

FUNCTION KEYS:

MODE: To select your specification and press for 2 seconds to restart.

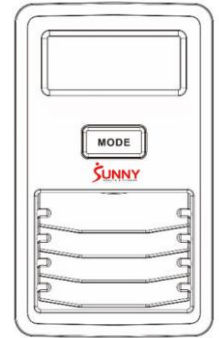

FUNCTIONS AND OPERATIONS:

AUTO ON/OFF: The power will turn off automatically once there is no signal for 4 minutes. The computer will reactivate once the machine is put into motion or when a computer button is pressed.

SCAN: Press MODE button until SCAN appears. The computer will rotate through the four functions in the following order: TIME, COUNT, TOTAL COUNT, and CALORIES. Each function will be held for 6 seconds.

TIME (TMR): Counts the total time elapsed during your current workout.

COUNT (CNT): Counts the number of rowing strokes from your current workout.

TOTAL COUNT (TOTAL CNT): Counts the total amount of strokes from the first use.

CALORIES (CAL): Counts the total calories burned from current workout.

BATTERY: This computer uses two AAA batteries. If the display appears incorrectly or becomes difficult to read, please install new batteries. Always change both batteries at the same time. Do not mix battery types and do not mix old and new batteries. Dispose batteries according to your state and regional guidelines.

APP CONNECTION

1. Scan below QR code to enter the app store and download the Sunny Health & Fitness app to your mobile phone.



2. Press the Bluetooth switch  to connect. Then you can use the app through your mobile phone.

SPECIFICATIONS

FUNCTIONS	SCAN	Every 6 seconds
	TIME	00:00~99:59 (Minute: Second)
	COUNT	0~9999 Count
	CALORIES	0.0~9999 Kcal
	TOTAL COUNT	0~9999 Count
BATTERY TYPE		(2) Two AAA or UM-4
OPERATING TEMPERATURE		0°C ~ 40°C
STORAGE TEMPERATURE		-10°C ~ 60°C

Version 1.0

CONNECT WITH US

FOR FITNESS
ARTICLES, VIDEOS
& WORKOUTS



@SUNNYHEALTHANDFITNESS



@SUNNYHEALTHFITNESS



@SUNNYHEALTHFIT



/SUNNYHEALTHFITNESS



/SUNNYHEALTHANDFITNESS

WWW.SUNNYHEALTHFITNESS.COM