

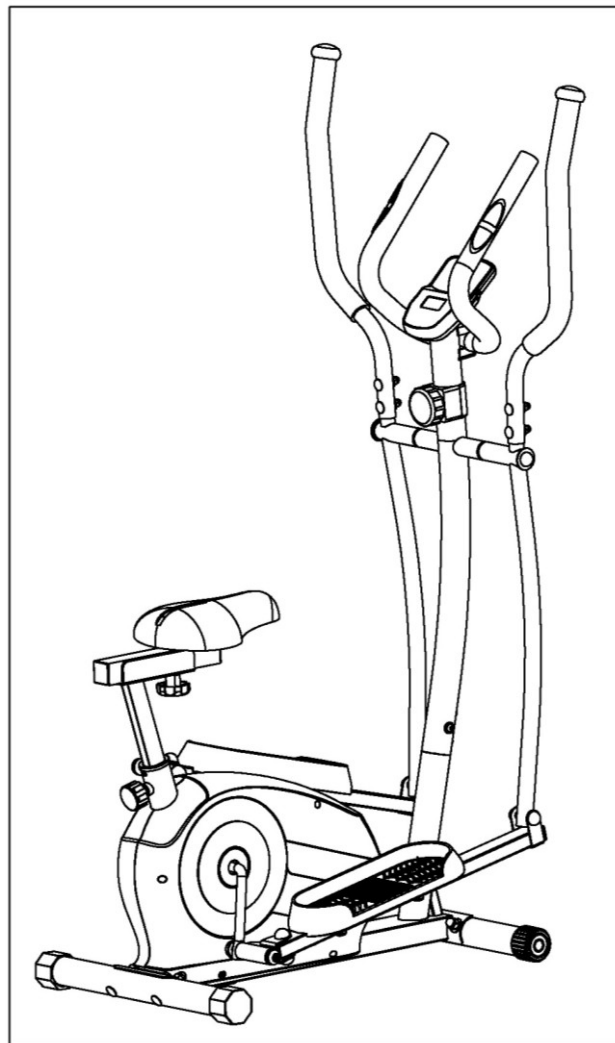

# ESSENTIAL INTERACTIVE SERIES SEATED ELLIPTICAL SF-E322004 USER MANUAL



**IMPORTANT!** Please retain owner's manual for maintenance and adjustment instructions. Your satisfaction is very important to us, **PLEASE DO NOT RETURN UNTIL YOU HAVE CONTACTED US:** [support@sunnyhealthfitness.com](mailto:support@sunnyhealthfitness.com) or 1-877-90SUNNY (877-907-8669).



[WWW.SUNNYHEALTHFITNESS.COM](http://WWW.SUNNYHEALTHFITNESS.COM)

# **IMPORTANT SAFETY INFORMATION**

We thank you for choosing our product. To ensure your safety and health, please use this equipment correctly. It is important to read this entire manual before assembling and using the equipment. Safe and effective use can only be achieved if the equipment is assembled, maintained and used properly. It is your responsibility to ensure that all users of the equipment are informed of all warnings and precautions.

1. Before starting any exercise program, you should consult your physician to determine if you have any medical or physical conditions that could put your health and safety at risk, or prevent you from using the equipment properly. Your physician's advice is essential if you are taking medication that affects your heart rate, blood pressure or cholesterol level.
2. Be aware of your body's signals. Incorrect or excessive exercise can damage your health. Stop exercising if you experience any of the following symptoms: pain, tightness in your chest, irregular heartbeat, shortness of breath, lightheadedness, dizziness or feelings of nausea. If you do experience any of these conditions, you should consult your physician before continuing with your exercise program.
3. Keep children and pets away from the equipment. The equipment is designed for adult use only.
4. Use the equipment on a solid, flat level surface with a protective cover for your floor or carpet. To ensure safety, the equipment should have at least 2 feet (60 cm) of free space all around it.
5. Ensure that all nuts and bolts are securely tightened before using the equipment. The safety of the equipment can only be maintained if it is regularly examined for damage and/or wear and tear.
6. Always use the equipment as indicated. If you find any defective components while assembling or checking the equipment, or if you hear any unusual noises coming from the equipment during exercise, discontinue use of the equipment immediately and do not use until the problem has been rectified.
7. Wear suitable clothing while using the equipment. Avoid wearing loose clothing that may become entangled in the equipment.
8. Do not place fingers or objects into the moving parts of the equipment.
9. The maximum weight capacity of this unit is 220 lbs (100 kgs).
10. The equipment is not suitable for therapeutic use.
11. To avoid bodily injury and/or damage to the product or property, proper lifting and moving is required.
12. Your product is intended for use in cool, dry conditions. You should avoid storage in extreme cold, hot or damp areas as this may lead to corrosion and other related problems.
13. This equipment is designed for indoor and home use only. It is not intended for commercial use!

# PRE-ASSEMBLY CHECK LIST

Before you start to assemble, please make sure all parts are included.

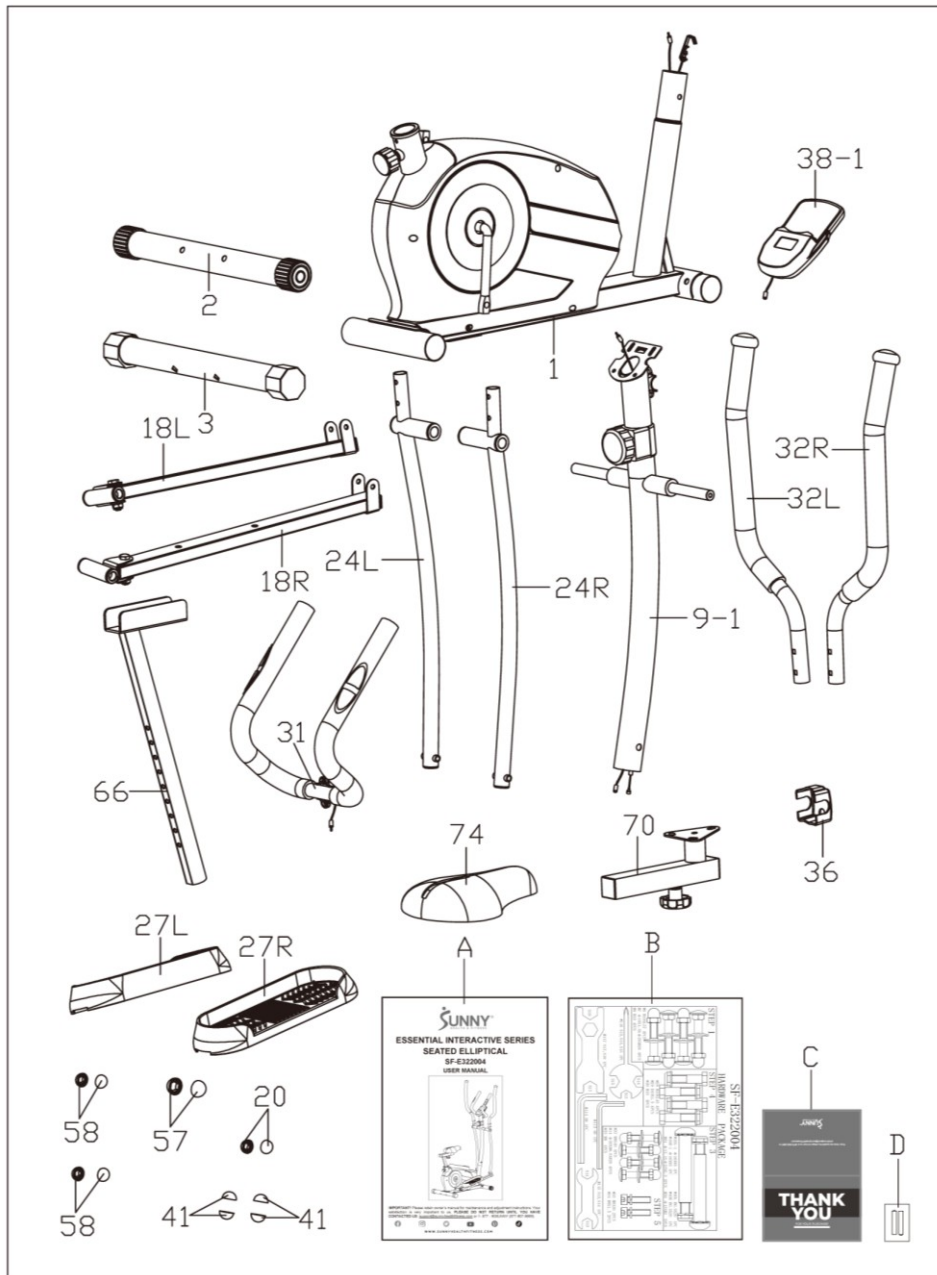

No.	Description	Spec.	Qty.
1	Main Frame		1
2	Front Stabilizer		1
3	Rear Stabilizer		1
9-1	Handlebar Post		1
18L	Left Pedal Support Tube		1
18R	Right Pedal Support Tube		1
20	Nut Cap	S13	2
24L	Left Swing Bar		1
24R	Right Swing Bar		1
27L	Left Pedal		1
27R	Right Pedal		1
31	Armrest		1
32L	Left Handlebar		1

32R	Right Handlebar		1
36	Decorative Cover	40X55X70	1
38-1	Meter	BJHT060	1
41	Nut Cap	S17	4
57	Nut Cap	S19	2
58	Nut Cap	S14	4
66	Seat Tube		1
70	Seat Horizontal Tube		1
74	Seat	DD982	1
A	Manual		1
B	Hardware Package		1
C	Thank You Card		1
D	Battery	AAA	2

# HARDWARE PACKAGE

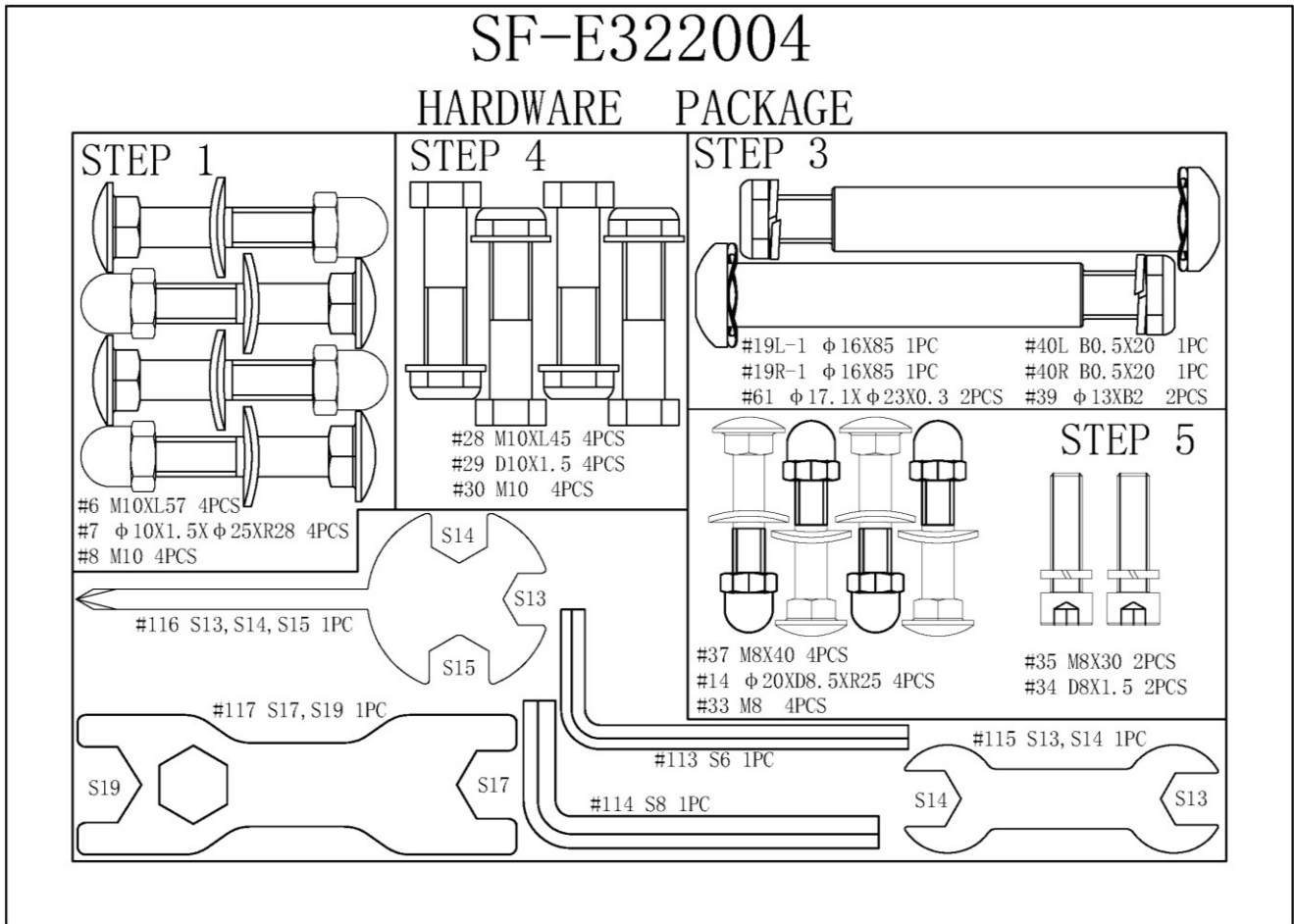

### Ordering Replacement Parts (U.S. and Canadian Customers only)

Please provide the following information in order for us to accurately identify the part(s) needed:

- ✓ The model number (found on cover of manual)
- ✓ The product name (found on cover of manual)
- ✓ The part number found on the "EXPLODED DIAGRAM" (page 15) and "PARTS LIST" (pages 13-14)

Please contact us at [support@sunnyhealthfitness.com](mailto:support@sunnyhealthfitness.com) or 1-877-90SUNNY (877-907-8669).

# ASSEMBLY INSTRUCTIONS

We value your experience using Sunny Health and Fitness products. For assistance with parts or troubleshooting, please contact us at [support@sunnyhealthfitness.com](mailto:support@sunnyhealthfitness.com) or 1-877-90SUNNY (877-907-8669).

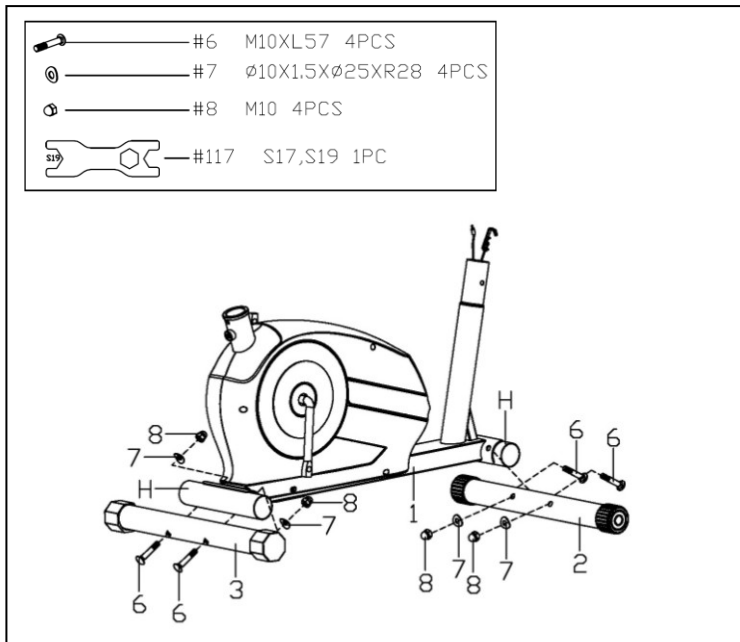

## STEP 1:

Remove 2 **Paper Tubes (No. H)** from the **Main Frame (No. 1)**.

Attach the **Front Stabilizer (No. 2)** and **Rear Stabilizer (No. 3)** onto the **Main Frame (No. 1)**, secure with 4 **Carriage Bolts (No. 6)**, 4 **Arc Washers (No. 7)** and 4 **Domed Nuts (No. 8)** by **Spanner (No. 117)**.

**NOTE:** Ensure that all bolts and washers are in place and partially threaded in before completely tightening any of them.

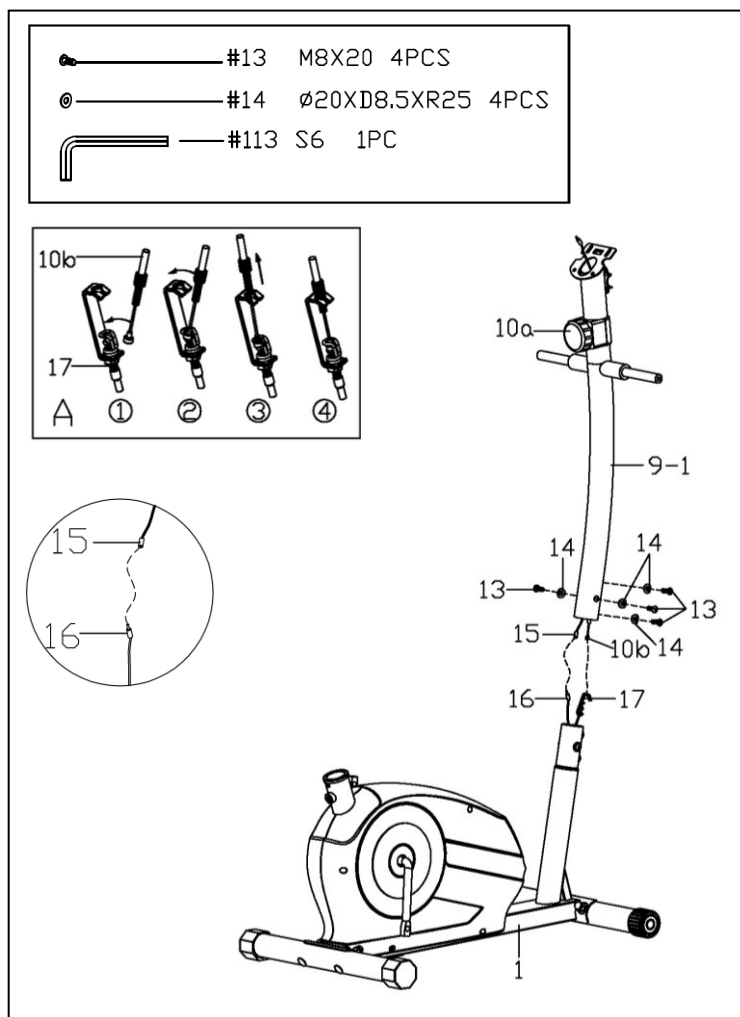

## STEP 2:

Connect the **Lower Sensor Wire (No. 16)** with the **Upper Sensor Wire (No. 15)**, and then connect **Tension Hook (No. 17)** with **Tension Cable (No. 10b)** as shown in Diagram A.

**NOTE:** Make sure the **Tension Controller (No. 10a)** is at the lowest level before you connect the **Tension Cable (No. 10b)**. This ensures the wires are at their longest point. We recommend the assistance of a second person to help hold the **Handlebar Post (No. 9-1)**. This will make the connection easier when you are attaching **Tension Hook (No. 17)** to **Tension Cable (No. 10b)**.

Remove 4 **Allen Bolts (No. 13)** and 4 **Arc Washers (No. 14)** from the **Main Frame (No. 1)**. Insert the **Handlebar Post (No. 9-1)** into the post of the **Main Frame (No. 1)**, with 4 **Allen Bolts (No. 13)** and 4 **Arc Washers (No. 14)** that were just removed. Tighten and secure with **Allen Wrench (No. 113)**.

**NOTE:** Ensure that all bolts and washers are in place and partially threaded in before completely tightening any of them.

We value your experience using Sunny Health and Fitness products. For assistance with parts or troubleshooting, please contact us at [support@sunnyhealthfitness.com](mailto:support@sunnyhealthfitness.com) or 1-877-90SUNNY (877-907-8669).

### STEP 3:

Remove 2 Wave Washers (No. 63), 2 Hex Bolts (No. 25) and 2 Flat Washers (No. 26) from the long axle of the Handlebar Post (No. 9-1) with Spanner (No. 116).

Attach 2 Wave Washers (No. 63) to the two sides of the long axle on the Handlebar Post (No. 9-1). Then attach the Left & Right Swing Bars (No. 24L & No. 24R) to the two sides of the long axle on the Handlebar Post (No. 9-1) with 2 Hex Bolts (No. 25) and 2 Flat Washers (No. 26) that were just removed. Tighten and secure with Spanner (No. 116).

**NOTE:** Please do not fully tighten at this time.

Attach the Connecting Joint (No. 52-1) on the Left Pedal Support Tube (No. 18L) to the left side of Crank Arm (No. 49-1) with 1 Left Hinge Bolt (No. 19L-1), 1 Wave Washer (No. 61). Turn the Left Hinge Bolt (No. 19L-1) *counter-clockwise* as tightly as you can with your hand. Secure by tightening 1 Spring Washer (No. 39) and 1 BLACK color Left Nylon Nut (No. 40L) *clockwise*. Then use Allen Wrench (No. 114) and Spanner (No. 117) to tighten securely.

Attach the Connecting Joint (No. 52-1) on the Right Pedal Support Tube (No. 18R) to the right side of Crank Arm (No. 49-1) with 1 Right Hinge Bolt (No. 19R-1), 1 Wave Washer (No. 61). Turn the Right Hinge Bolt (No. 19R-1) *clockwise* as tightly as you can with your hand. Secure by tightening 1 Spring Washer (No. 39) and 1 WHITE color Right Nylon Nut (No. 40R) *counter-clockwise*. Then use Allen Wrench (No. 114) and Spanner (No. 117) to tighten securely.

**NOTE:** Please do not fully tighten at this time. Please attach the Left & Right Hinge Bolts (No. 19L-1 & No. 19R-1) correctly as Fig.1 showed.

Remove 2 Hex Bolts (No. 21), 2 Flat Washers (No. 22) and 2 Nylon Nuts (No. 23) from Left & Right Pedal Support Tubes (No. 18L & No. 18R) using Spanner (No. 116) and Spanner (No. 115). Then attach the Left & Right Swing Bars (No. 24L & No. 24R) to the Left & Right Pedal Support Tubes (No. 18L & No. 18R) with 2 Hex Bolts (No. 21), 2 Flat Washers (No. 22) and 2 Nylon Nuts (No. 23) that were just removed. Tighten and secure with Spanner (No. 116) and Spanner (No. 115).

**NOTE:** If fail to screw in Hex Bolts (No. 21), please move the Crank Arm (No. 49-1) to a different angle and retry it.

Tighten 2 Hex Bolts (No. 25) and Left & Right Nylon Nuts (No. 40L & No. 40R) tightly now. Then cover with the 12 Nut Caps (No. 20 & No. 58 & No. 57 & No. 41).

	#25 M8X15 2PCS		#116 S13,S14,S15 1PC
	#26 Ø8,2XØ32X2 2PCS		#115 S13,S14 1PC
	#21 M8X55 2PCS		#117 S17,S19 1PC
	#22 D8X1.5 2PCS		#114 S8 1PC
	#23 M8 2PCS		
	#19L-1 Ø16X85 1PC		
	#19R-1 Ø16X85 1PC		
	#61 Ø17.1XØ23X0.3 2PCS		
	#40L B0.5X20 1PC		
	#40R B0.5X20 1PC		
	#39 Ø13XB2 2PCS		
	#63 Ø20XØ28X0.6 2PCS		

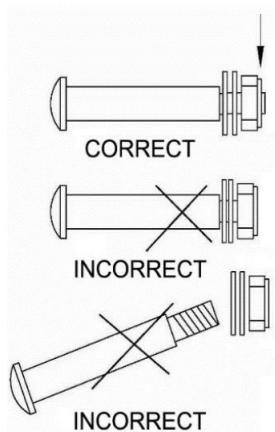
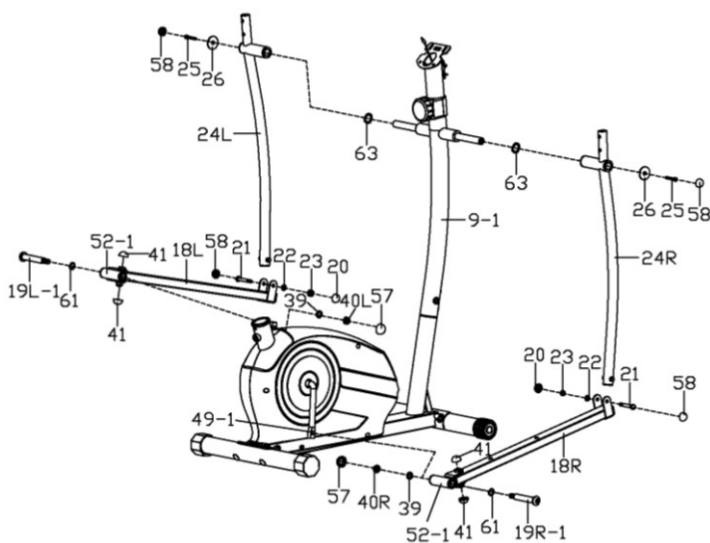
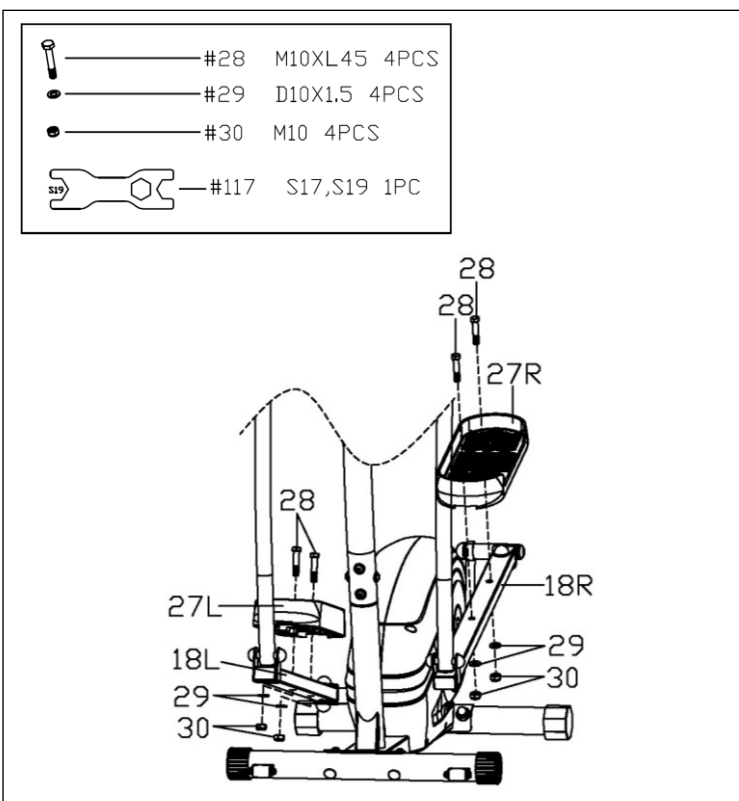

Fig.1

We value your experience using Sunny Health and Fitness products. For assistance with parts or troubleshooting, please contact us at [support@sunnyhealthfitness.com](mailto:support@sunnyhealthfitness.com) or 1-877-90SUNNY (877-907-8669).



**STEP 4:**

Secure the **Left & Right Pedals (No. 27L & No. 27R)** to the **Left & Right Pedal Support Tubes (No. 18L & No. 18R)** respectively by using 4 Hex Bolts (No. 28), 4 Flat Washers (No. 29) and 4 Nylon Nuts (No. 30) by using Spanner (No. 117).

**CAUTION:**

Both pedals are labeled L and R; L for LEFT and R for RIGHT.

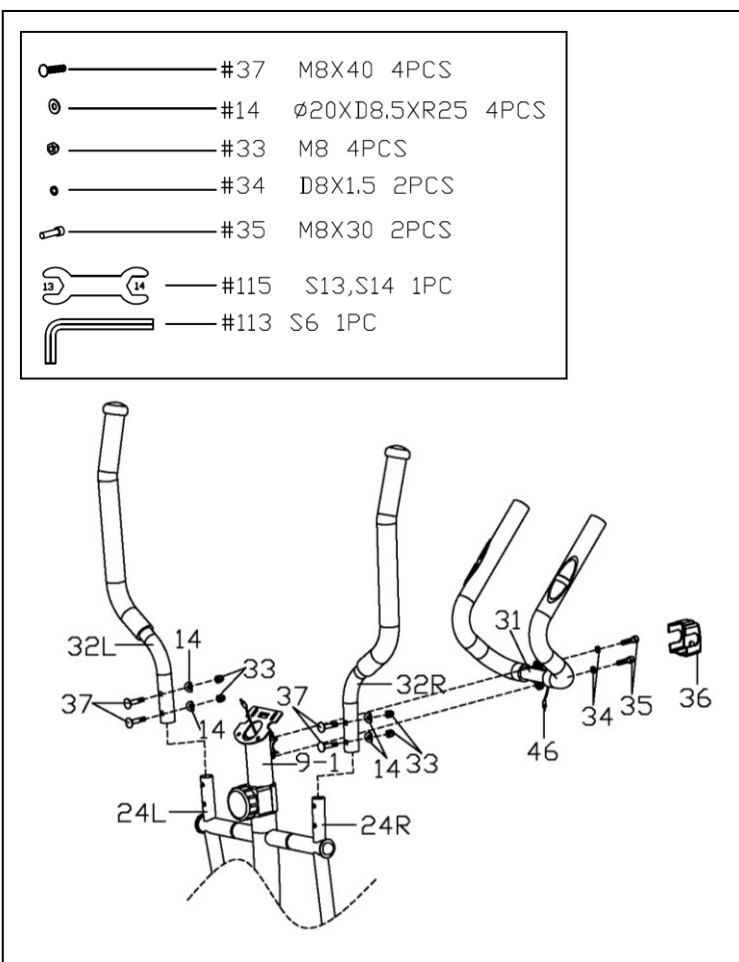

**STEP 5:**

Attach **Armrest (No. 31)** to the **Handlebar Post (No. 9-1)** in place. Secure it with 2 **Spring Washers (No. 34)** and 2 **Hex Bolts (No. 35)** using **Allen Wrench (No. 113)**. Finally attach the **Decorative Cover (No. 36)** onto the **Armrest (No. 31)**.

Attach the **Left & Right Handlebars (No. 32L & No. 32R)** onto the **Left & Right Swing Bars (No. 24L & No. 24R)** with 4 **Carriage Bolts (No. 37)**, 4 **Arc Washers (No. 14)** and 4 **Domed Nuts (No. 33)**. Tighten and secure with **Spanner (No. 115)**.

**NOTE:** If the **Left & Right Handlebars (No. 32L & No. 32R)** rubs against the **Armrest (No. 31)** during the workout please recheck if the **Left & Right Handlebars (No. 32L & No. 32R)** is assembled to **Left & Right Swing Bars (No. 24L & No.24R)** according to the label marked with L or R.

We value your experience using Sunny Health and Fitness products. For assistance with parts or troubleshooting, please contact us at [support@sunnyhealthfitness.com](mailto:support@sunnyhealthfitness.com) or 1-877-90SUNNY (877-907-8669).

### STEP 6:

Remove 4 **Phillips Screws (No. 62)** from the **Meter (No. 38-1)** with **Spanner (No. 116)**.

Plug the **Pulse Sensor Wire (No. 46)** to the jack on the back of the **Meter (No. 38-1)**. Then connect the **Upper Sensor Wire (No. 15)** to the **Meter Wire (No. 38-1a)**.

Attach the **Meter (No. 38-1)** to the bracket of the **Handlebar Post (No. 9-1)** using 4 **Phillips Screws (No. 62)** that were just removed. Tighten and secure with **Spanner (No. 116)**.

**NOTE:** To avoid damaging the wires, please push them into the **Handlebar Post (No. 9-1)** before securing the **Meter (No. 38-1)** onto the bracket.

### STEP 7:

Remove 3 **Flat Washers (No. 73)** and 3 **Nylon Nuts (No. 72)** from the **Seat (No. 74)** using the **Spanner (No. 116)**.

Lock the **Seat (No. 74)** to the **Seat Horizontal Tube (No. 70)** and lock with 3 **Flat Washers (No. 73)** and 3 **Nylon Nuts (No. 72)** that were just removed. Tighten and secure with the **Spanner (No. 116)**.

Remove the **Flat Washer (No. 68)** and **Plum Nut (No. 67)** from the **U Shape Bracket (No. 69)**.

Attach the **Seat Horizontal Tube (No. 70)** to the **Seat Tube (No. 66)**, then tighten and secure with **Flat Washer (No. 68)** and **Plum Nut (No. 67)** that were just removed.

Insert the **Seat Tube (No. 66)** to the post of **Main Frame (No. 1)**, adjust to the proper height, then tighten and secure with the **Pop-pin Knob (No. 64)**.

**NOTE:** Before exercise, make sure the **Seat (No. 74)** is tightly locked to the post of **Seat Horizontal Tube (No. 70)**.

**THE ASSEMBLY IS COMPLETE!**

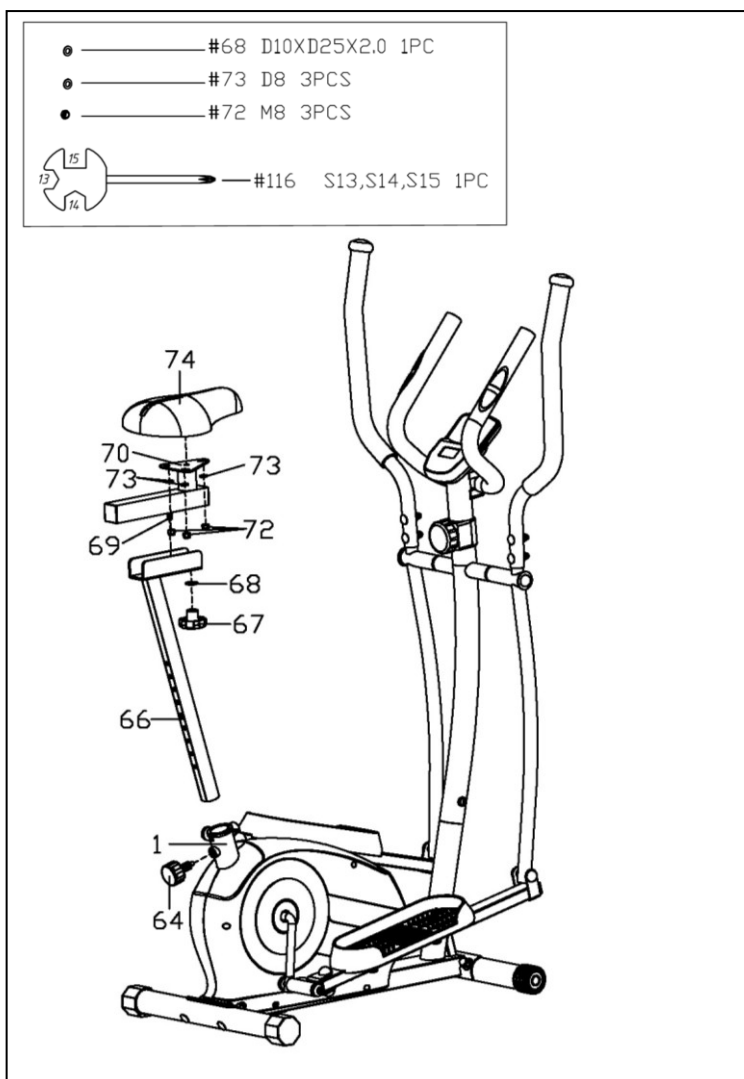
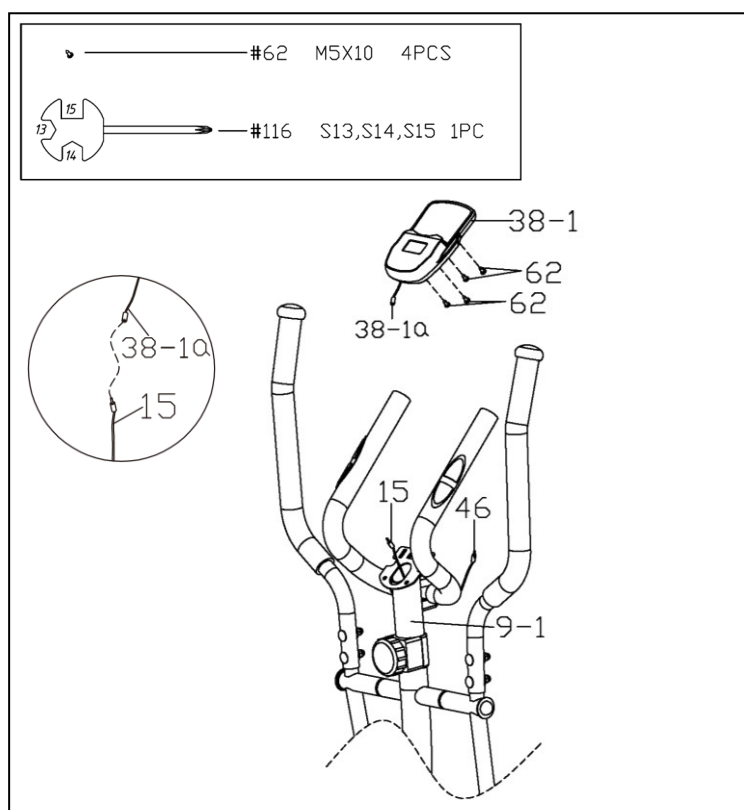



# TROUBLESHOOTING

1. If you find there is no difference between tension level 1 to level 8, please check the connection of the tension cable. Please see Diagram A under STEP 2.

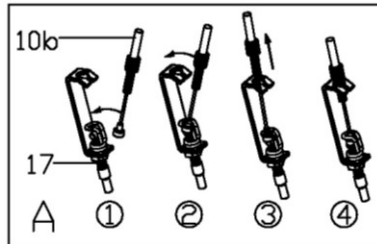

2. If the meter does not show numbers correctly, please check the batteries. If the meter does not count the speed and time, please check the connections of **Upper Sensor Wire (No. 15)** to the **Meter Wire (No. 38-1a)** and **Upper Sensor Wire (No. 15)** to **Lower Sensor Wire (No. 16)**.
3. If you have difficulty in putting **Left & Right Hinge Bolts (No. 19L-1 & No. 19R-1)** into the **Crank Arm (No. 49-1)**, or putting **Hex Bolts (No. 21)** into **Left & Right Pedal Support Tubes (No. 18L & No. 18R)**, please try moving the **Crank Arm (No. 49-1)** to a different angle. \*Keep in mind the **Left Hinge Bolt (No. 19L-1)** has reversed threading and must be installed by turning counter-clockwise.
4. If you hear any noise when using the machine, please check if **Left & Right Hinge Bolts (No. 19L-1 & No. 19R-1)**, **Hex Bolts (No. 21)**, **Hex Bolts (No. 25)** and **Connecting Joints (No. 52-1)** are loose. You may remove these parts and add some lubricant oil to eliminate all noise possibilities. Remember to tighten all the parts securely.
5. If it is very hard to pedal on the higher tension levels, or you hear rubbing noises, please remove the **Left & Right Belt Covers (No. 101L & No. 101R)**, and adjust the **Hex Bolt (No. 107)** seen in the following diagram. You will need to loosen the 2 **Hex Nuts (No. 90)** and lower the position of the **Hex Bolt (No. 107)** by turning counter-clockwise. This will keep the **Magnetic Board (No. 84)** from contacting the magnetic flywheel. Before re-installing the **Left & Right Belt Covers (No. 101L & No. 101R)**, test the tension level 8 to ensure the magnets do not touch the flywheel.

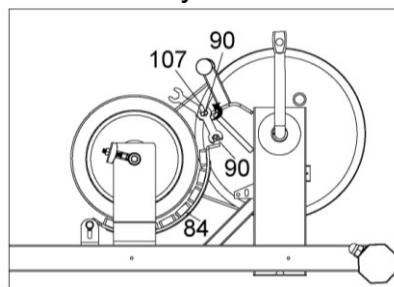

6. If you still hear noises after you did STEP 4 and STEP 5, please remove the Left & Right Belt Covers (No. 101L & No. 101R). Loosen the Hex Thin Nut (No. 87) for the Flywheel (No. 94) about a half of a rotation. See the following diagram below.

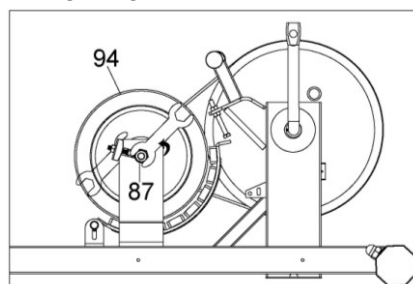

7. If you feel the machine is uneven, please adjust the **Leveler Caps (No. 5)** on **Rear Stabilizer (No. 3)** by turning it. If the machine is wobbly when you use it, please consider adding an exercise mat under it.

# ADJUSTMENT GUIDE

10a

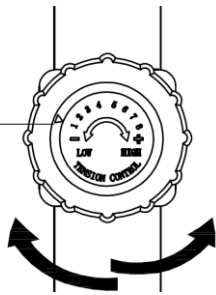

## ADJUSTING THE TENSION

Adjust the tension by rotating the **Tension Controller (No. 10a)** *clockwise* to increase the level of resistance. Rotate the **Tension Controller (No. 10a)** *counter-clockwise* to decrease the level of resistance.

Tension levels are set at Level 1 being the lowest and Level 8 being the highest.

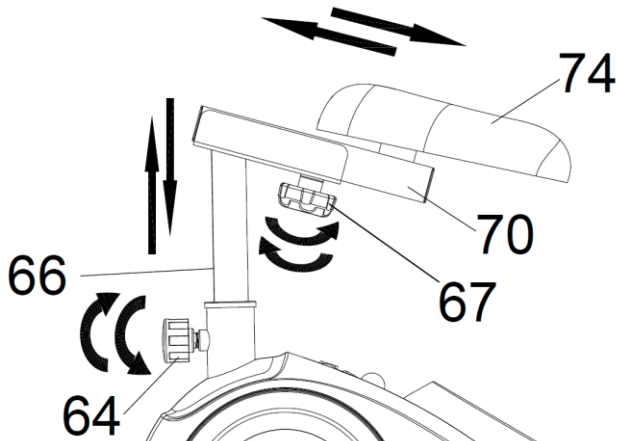

## ADJUSTING THE SEAT

The **Seat (No. 74)** of this bike is fully adjustable as it moves *Up, Down, Fore (forward), Aft (backward)*.

To adjust the height of the **Seat Tube (No. 66)**, loosen and pull the **Pop-pin Knob (No. 64)** outward, then raise or lower the **Seat (No. 74)** to the desired height. Once adjusted, re-insert and tighten the **Pop-pin Knob (No. 64)** to secure the **Seat (No. 74)** in place.

To adjust the **Seat (No. 74)** back and forth, loosen the **Plum Nut (No. 67)** and slide the **Seat Horizontal Tube (No. 70)** to the desired position. Then tighten the **Plum Nut (No. 67)** to secure the **Seat Horizontal Tube (No. 70)** in place.

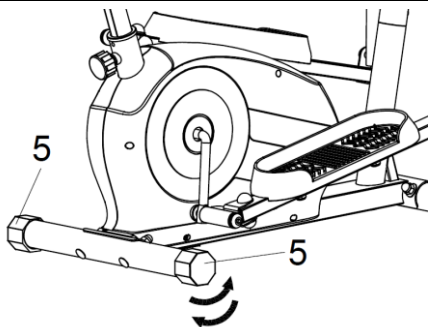

## ADJUSTING THE LEVEL

If at any point the bike does not feel level, you can adjust the **Leveler Caps (No. 5)**. If the machine is wobbly when you use it, please consider adding an exercise mat under it.

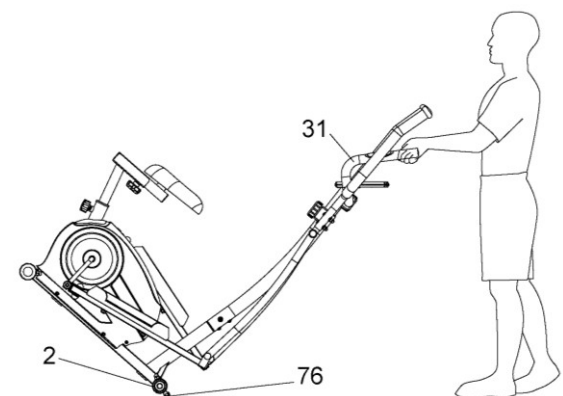

## HOW TO MOVE THE ELLIPTICAL

There are **Transportation Wheels (No. 76)** located on the **Front Stabilizer (No. 2)**. Hold the **Armrest (No. 31)** and push down the front of the elliptical until the **Transportation Wheels (No. 76)** touch the ground. Now you can move the elliptical.

# BATTERY INSTALLATION & REPLACEMENT

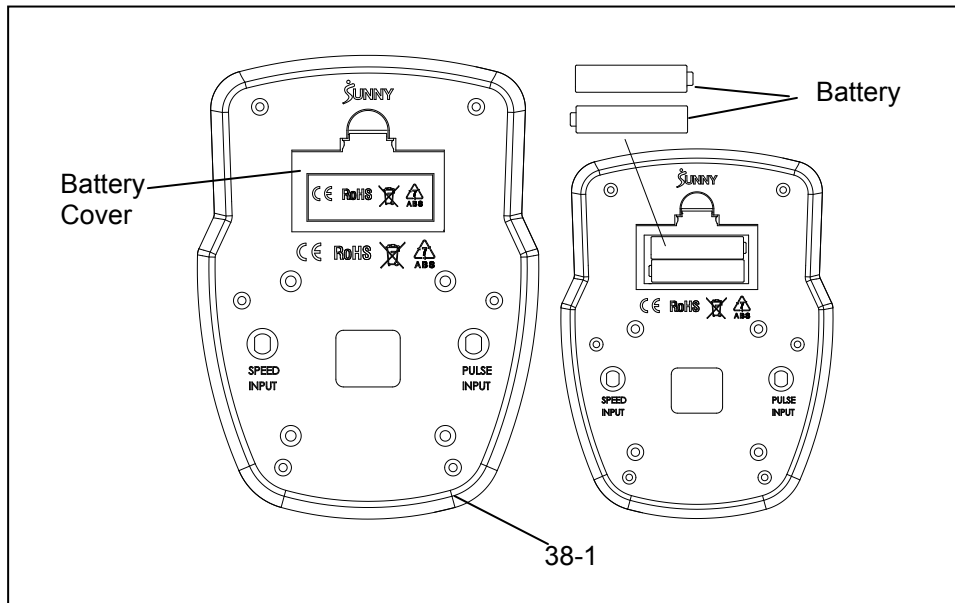

## **BATTERY INSTALLATION**

1. Take out 2 AAA batteries from meter box.
2. Press the buckle of battery cover on the **Meter (No. 38-1)**, then remove battery cover.
3. Install 2 AAA batteries into the battery case on the back of the **Meter (No. 38-1)**. Pay attention to the battery + and – poles before installing.
4. Press the buckle of battery cover, then put the battery cover back to the back of the **Meter (No. 38-1)**.

*The installation is complete!*

## **BATTERY REPLACEMENT**

1. Press the buckle of battery cover on the back of the **Meter (No. 38-1)**, then remove battery cover.
2. Remove the 2 old AAA batteries in the battery case and install 2 new AAA batteries into the battery case on the back of the **Meter (No. 38-1)**. Pay attention to the battery + and – poles before installing.
3. Press the buckle of battery cover, then put the battery cover back to the back of the **Meter (No. 38-1)**.

*The replacement is complete!*

## **BATTERY DISPOSAL**

Dispose the batteries according to the laws and regulations of your local region. Some batteries may be recycled. When disposing or recycling, do not mix battery types.

# EXERCISE METER

## ■KEY FUNCTION

- This key lets you select and lock on to a particular function you want.  
SCAN→TIME→SPD (SPEED) →DIST (DISTANCE)  
→CAL (CALORIES)→ODO (TOTAL DISTANCE)  
→RPM →PULSE
- Press and hold for 3 seconds to reset the value to zero [without resetting ODO (TOTAL DISTANCE)].

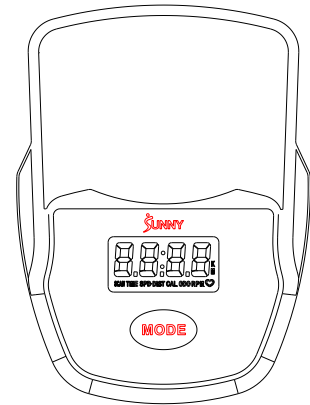

## ■SLEEP MODE

- The system turns off automatically if no activity or keys pressed for approximately 4 minutes.
- The system turns on when the MODE key is pressed or activity is signaled.

## ■FUNCTION

- SCAN: Meter will rotate through all functions every 6 seconds.
- TIME: Counts the total time from start to finish.
- SPD (SPEED): Displays the current speed.
- DIST (DISTANCE): Counts the distance of an exercise from start to finish.
- CAL (CALORIES): Counts total calories burned during exercise from start to finish.
- ODO (TOTAL DISTANCE): Counts the total distance from when batteries were installed. If the batteries are replaced, the value returns to zero.
- RPM: The average number of turns per minute of the wheel to measure the speed of the pedal.
- PULSE: The current pulse rate.

## ■SPECIFICATIONS

FUNCTION	SCAN	6S
	TIME	0:00-99:59 (M:S)
	SPD (SPEED)	0.0~999.9 MPH
	DIST (DISTANCE)	0.00~999.9 MILE
	ODO (TOTAL DISTANCE)	0.0~999.9 MILE
	CAL (CALORIES)	0.0~999.9 KCAL
	PULSE	40~240 BPM
BATTERY		SIZE-AAA, 2PCS
OPERATING TEMPERATURE		0~40°C (32°F-104°F)
STORAGE TEMPERATURE		-10~60°C (14°F-140°F)

## APP CONNECTION:

Connect Smart Equipment to SunnyFit App:

1. Scan to download SunnyFit from the app store:



2. Ensure that the Bluetooth function is turned on from your mobile device.
3. If this is your first time using the SunnyFit app, follow the in-app instructions to register for your free SunnyFit account and log in.
4. Begin any workout activity that matches your smart equipment, then follow the onscreen prompts to search for and connect to your smart equipment.
5. When connected, your stats and records will be displayed at the end of your course/session, and recorded in your account profile!

Troubleshooting:

- If you are having trouble connecting your smart equipment, visit [www.sunnyfit.com/guide](http://www.sunnyfit.com/guide) or scan the QR code below:



- If you require additional support, please contact [support@sunnyfit.com](mailto:support@sunnyfit.com).

# PARTS LIST

No.	Description	Spec.	Qty.
1	Main Frame		1
2	Front Stabilizer		1
3	Rear Stabilizer		1
4	End Cap	Φ50X1.5	2
5	Leveler Cap	Φ50X1.5	2
6	Carriage Bolt	M10XL57	4
7	Arc Washer	Φ10X1.5XΦ25XR28	4
8	Domed Nut	M10	4
9-1	Handlebar Post		1
10a	Tension Controller	8-level	1
10b	Tension Cable	L590	1
11	Phillips Screw	M5X45	1
12	Flat Washer	D5	1
13	Allen Bolt	M8X20	4
14	Arc Washer	Φ20XD8.5XR25	8
15	Upper Sensor Wire	900mm	1
16	Lower Sensor Wire	1200mm	1
17	Tension Hook	L1300	1
18L	Left Pedal Support Tube		1
18R	Right Pedal Support Tube		1
19L-1	Left Hinge Bolt	Φ16X85	1
19R-1	Right Hinge Bolt	Φ16X85	1
20	Nut Cap	S13	2
21	Hex Bolt	M8X55	2
22	Flat Washer	D8X1.5	2
23	Nylon Nut	M8, Nickel	2
24L	Left Swing Bar		1
24R	Right Swing Bar		1
25	Hex Bolt	M8X15	2
26	Flat Washer	Φ8.2XΦ32X2	2
27L	Left Pedal		1
27R	Right Pedal		1
28	Hex Bolt	M10XL45	4
29	Flat Washer	D10X1.5	4
30	Nylon Nut	M10, Black	4
31	Armrest		1
32L	Left Handlebar		1
32R	Right Handlebar		1
33	Domed Nut	M8	4
34	Spring Washer	D8X1.5	2
35	Hex Bolt	M8X30	2
36	Decorative Cover	40X55X70	1
37	Carriage Bolt	M8X40	4
38-1	Meter	BJHT060	1
38-1a	Meter Wire		1
39	Spring Washer	Φ13XB2	2
40L	Left Nylon Nut	B0.5X20	1
40R	Right Nylon Nut	B0.5X20	1
41	Nut Cap	S17	4
42	Square End Cap	40X25X1.5	4
43	Foam Grip	Φ23XΦ32X480	2
44	Foam Grip	Φ26XΦ36X480	2
45	Round End Cap	Φ28X1.5	2
46	Pulse Sensor Wire	600mm	1
47	Spherical Cap	Φ25X1.5	2

No.	Description	Spec.	Qty.
48	Mushroom Cap	Φ28.6X1.5	2
49-1	Crank Arm	L140XW228	1
50	Tension Controller Cover		1
51	Hex Bolt	M10X50	2
52-1	Connecting Joint		2
53	Axle Bushing 1	Φ24X16XΦ16.1	4
54	Pulse Sensor		2
55	Alloy Bushing	Φ14X12.5XΦ10.1	4
56	Nylon Nut	M10, Nickel	2
57	Nut Cap	S19	2
58	Nut Cap	S14	4
59	Spacer	Φ32X59	2
60	Axle Bushing 2	Φ32X2.5	4
61	Wave Washer	Φ17.1XΦ23X0.3	2
62	Phillips Screw	M5X10	4
63	Wave Washer	Φ20XΦ28X0.6	2
64	Pop-pin Knob	M16X1.5XL27	1
65	Seat Tube Bushing	Φ50XΦ38	1
66	Seat Tube		1
67	Plum Nut	M10	1
68	Flat Washer	D10XD25X2.0	1
69	U Shape Bracket		1
70	Seat Horizontal Tube		1
71	Square Cap	38X38X1.5	2
72	Nylon Nut	M8, Galvanized	3
73	Flat Washer	D8	3
74	Seat	DD982	1
75	Hex Bolt	M6XL45	2
76	Transportation Wheel	Φ23X32XΦ6	2
77	Nylon Nut	M6	2
78	Flat Washer	D10X1.5	2
79	Hex Bolt	M6X15	2
80	Spring Washer	Φ6	2
81	Flat Washer	D6	2
82	Axle Stop Ring	D12	2
83	Magnetic Board Axle	Φ12X50	1
84	Magnetic Board		1
85	Spring	L61XΦ15XΦ1.6	1
86	Square Magnet	40X25X10	8
87	Hex Thin Nut	M10X1	2
88	Adjusting Belt Bolt	M6X50	2
89	Adjusting U Washer	3X30X20	2
90	Hex Nut	M6	4
91	Phillips Screw	ST4.2X18	2
92	Bearing	6000	2
93	Flywheel Axle	Φ10XM10X1XL118	1
94	Flywheel	Φ200X38	1
95	Bolt	ST4.3X20	6
96	Plug	13X1.5	2
97	Bolt	ST5X20	4
98	Plastic Nut	S17	1
99	Nut	M10X1.0	2
100	Crank Cover		2
101L	Left Belt Cover		1
101R	Right Belt Cover		1

No.	Description	Spec.	Qty.
102	Nut	7/8"X24	1
103	Washer	Φ22.6XΦ28X2.5	1
104	Locking Nut-L	Φ45XH3.5XΦ33.5	1
105	Open Face Bearing	Φ45.8X8.8	2
106	Bearing Housing	2.5X76X76	2
107	Hex Bolt	M6X55	1
108	Bolt	ST3X10	2
109	Locking Nut-R	Φ45XH3.5XΦ33.5	1
110	Flat Washer	Φ25.2XΦ38X1	1

No.	Description	Spec.	Qty.
111	Flat Belt	380 PJ6	1
112	Belt Pulley	Φ260	1
113	Allen Wrench	S6	1
114	Allen Wrench	S8	1
115	Spanner	S13, S14	1
116	Spanner	S13, S14, S15	1
117	Spanner	S17, S19	1
118	Wire Plug	Φ12.5	1





**CONNECT**  
with us

## DOWNLOAD

Track your fitness progress & join  
**FREE** workout courses!

Download  **SUNNYFIT** today!



---

## FOLLOW

Find us on social media @sunnyhealthfitness

 @sunnyhealthfitness

 @sunnyhealthandfitness

 @sunnyhealthfit

 /sunnyhealthfitness

 /sunnyhealthfitness

 /sunnyhealthandfitness

[www.sunnyhealthfitness.com](http://www.sunnyhealthfitness.com)