

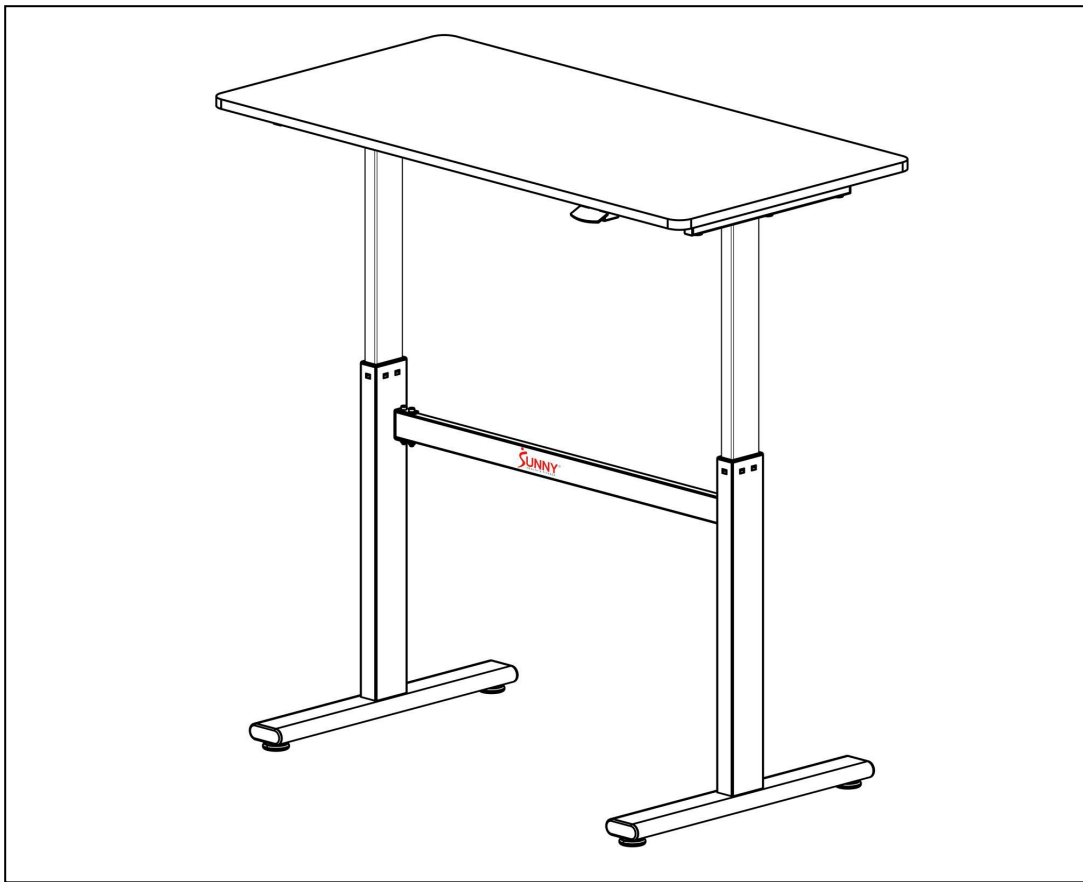

# MULTI-PURPOSE AIR-DRIVE ADJUSTABLE STANDING DESK

## SF-A023001

## USER MANUAL



**IMPORTANT!** Please retain owner's manual for maintenance and adjustment instructions. Your satisfaction is very important to us, **PLEASE DO NOT RETURN UNTIL YOU HAVE CONTACTED US:** [support@sunnyhealthfitness.com](mailto:support@sunnyhealthfitness.com) or 1-877-90SUNNY (877-907-8669).



WWW.SUNNYHEALTHFITNESS.COM

# **IMPORTANT SAFETY INSTRUCTIONS**

When using this product, basic precautions should always be followed, including the following:

Read all instructions before using this equipment.

**WARNING** – To reduce the risk of burns, fire, or injury to persons:

1. Please assemble in strict accordance with the instructions.
2. The product is only for indoor use. Please avoid long-term exposure to humid environments.
3. The installation parts need to be placed on a mat (rubber or wood) to avoid getting dirty.
4. During the assembly, align all bolts with the corresponding pre-drilled holes and tighten one by one.
5. Ensure that all nuts and bolts are tightened before use.
6. To ensure the safety of users, please check whether all bolts and other connecting parts are locked before each use.
7. Check the screws regularly. Long-term use may cause screws to loosen. Retighten if necessary to ensure stability and safety.
8. Do not use corrosive detergent to clean table.
9. Children are not allowed to assemble the product. During the assembly, please place all parts out of the reach of children.
10. Do not allow children to stand, climb or play with the product to avoid serious personal injury.
11. Keep plastic bags out of reach of children to avoid choking and other potential hazards.

**SAVE THESE INSTRUCTIONS**



# **IMPORTANT SAFETY INFORMATION**

We thank you for choosing our product. To ensure your safety and health, please use this equipment correctly. It is important to read this entire manual before assembling and using. Safe and effective use can only be achieved if the equipment is assembled, maintained and used properly. It is your responsibility to ensure that all users of the equipment are informed of all warnings and precautions.

1. Use the equipment on a solid, flat level surface with a protective cover for your floor or carpet.
2. Ensure that all nuts and bolts are tightened securely before using. The safety of the equipment can only be maintained if it is regularly examined for damage and/or wear and tear.
3. Always use the equipment as indicated. If you find any defective components while assembling, checking the equipment, or if you hear any unusual noises coming from the equipment during using, discontinue use of the equipment immediately and do not use until the problem has been rectified.
4. Do not place fingers or objects into the moving parts of the equipment.
5. The static maximum weight capacity of this unit is 187 lbs (85 kgs). Lift stroke is 29.5 inch-47.2 inch (750mm-1200mm).
6. Your product is intended for use in cool and dry conditions. You should avoid storage in extreme cold, hot, or damp areas as this may lead to corrosion and other related problems.
7. This equipment is designed for indoor and home use only.

# PRE-ASSEMBLY CHECK LIST

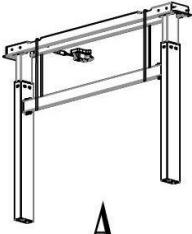
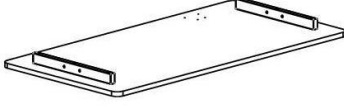
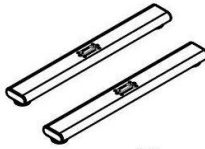
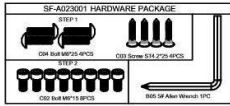
Before you start to assemble, please make sure all parts are included.

 <p style="text-align: center;"><b>A</b></p>	 <p style="text-align: center;"><b>B</b></p>	 <p style="text-align: center;"><b>C</b></p>
 <p style="text-align: center;"><b>D</b></p>	 <p style="text-align: center;"><b>E</b></p>	 <p style="text-align: center;"><b>F</b></p>

No.	Description	Spec.	Qty.
A	Main Frame		1
B	Table Board Set		1
C	Foot Tube Set		2
D	Hardware Package		1
E	THANK YOU Card		1
F	Manual		1

# HARDWARE PACKAGE

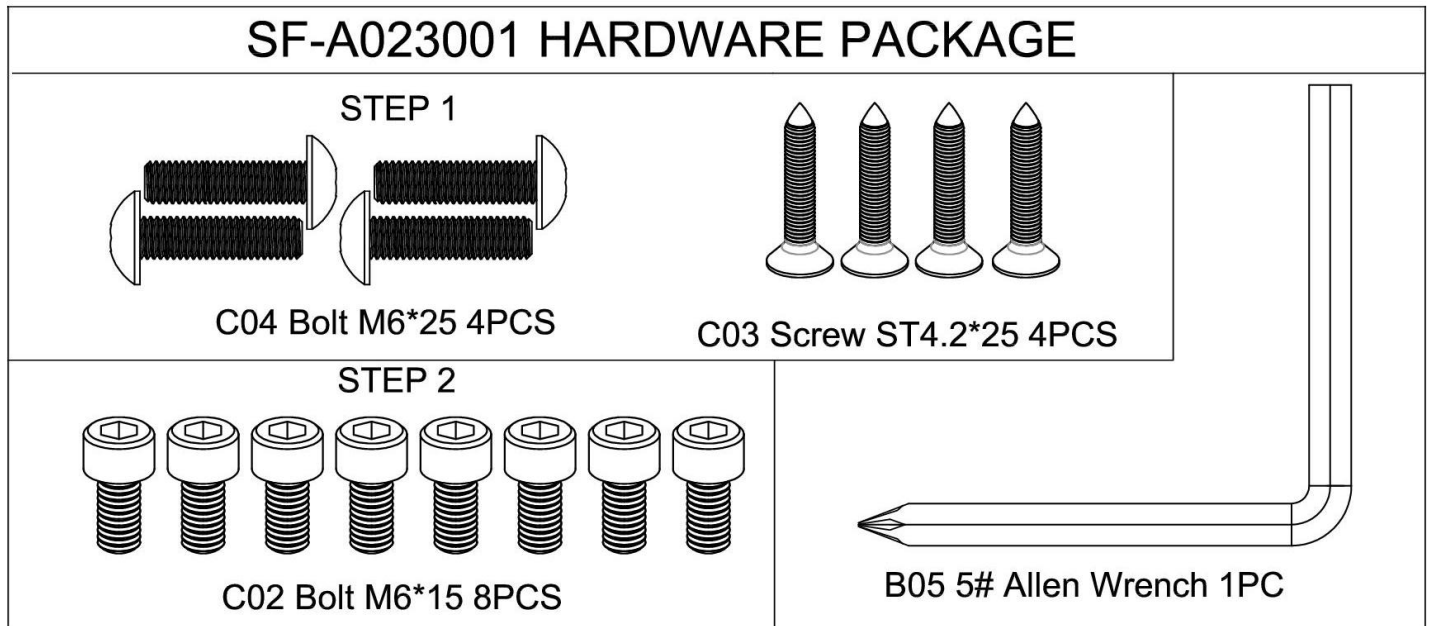

## Ordering Replacement Parts (U.S. and Canadian Customers only)

Please provide the following information in order for us to accurately identify the part(s) needed:

- ✓ The model number (found on cover of manual)
- ✓ The product name (found on cover of manual)
- ✓ The part number found on the "EXPLODED DIAGRAM" and "PARTS LIST" (found near the end of the manual)

Please contact us at [support@sunnyhealthfitness.com](mailto:support@sunnyhealthfitness.com) or 1-877-90SUNNY (877-907-8669).

# ASSEMBLY INSTRUCTIONS

We value your experience using Sunny Health and Fitness products. For assistance with parts or troubleshooting, please contact us at [support@sunnyhealthfitness.com](mailto:support@sunnyhealthfitness.com) or 1-877-90SUNNY (877-907-8669).

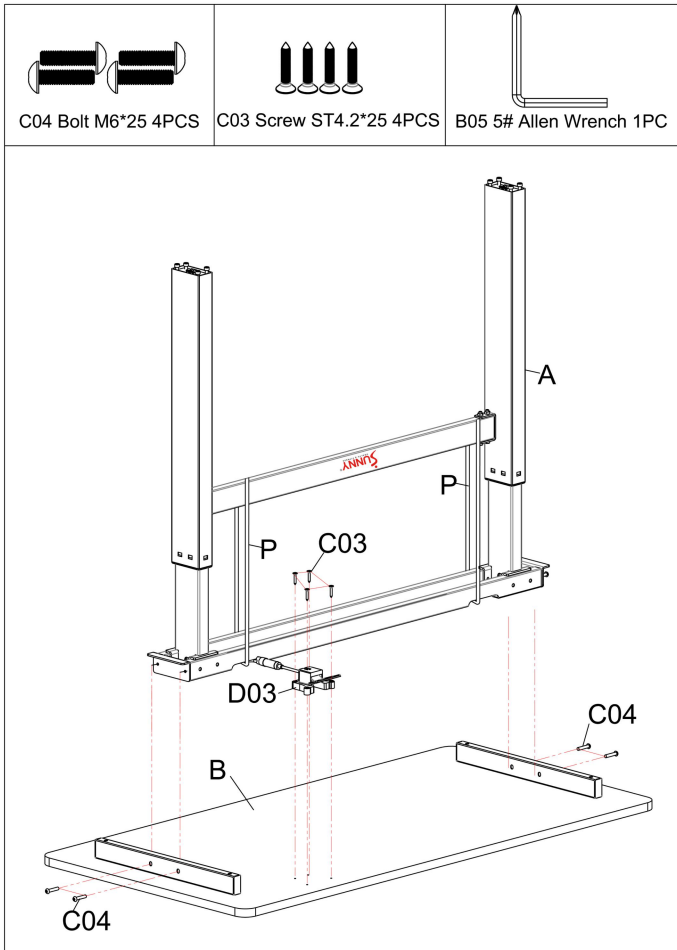

## STEP 1:

Open the carton and remove contents.

**NOTE:** DO NOT cut the 2 **Packing Belts (No. P)** on **Main Frame (No. A)**.

Place the **Table Board Set (No. B)** down on level ground, ensure that you have a work area that is clean and has adequate space.

There is a “Sunny” logo marked on the **Main Frame (No. A)**. Please ensure the logo is facing the **Wrench Bracket (No. D03)**.

Attach the **Main Frame (No. A)** to the **Table Board Set (No. B)** by using 4 **Bolts (No. C04)**. Tighten and secure with **5# Allen Wrench (No. B05)**.

Attach the **Wrench Bracket (No. D03)** to the **Table Board Set (No. B)** by using 4 **Screws (No. C03)**. Tighten and secure with **5# Allen Wrench (No. B05)**.

We value your experience using Sunny Health and Fitness products. For assistance with parts or troubleshooting, please contact us at [support@sunnyhealthfitness.com](mailto:support@sunnyhealthfitness.com) or 1-877-90SUNNY (877-907-8669).

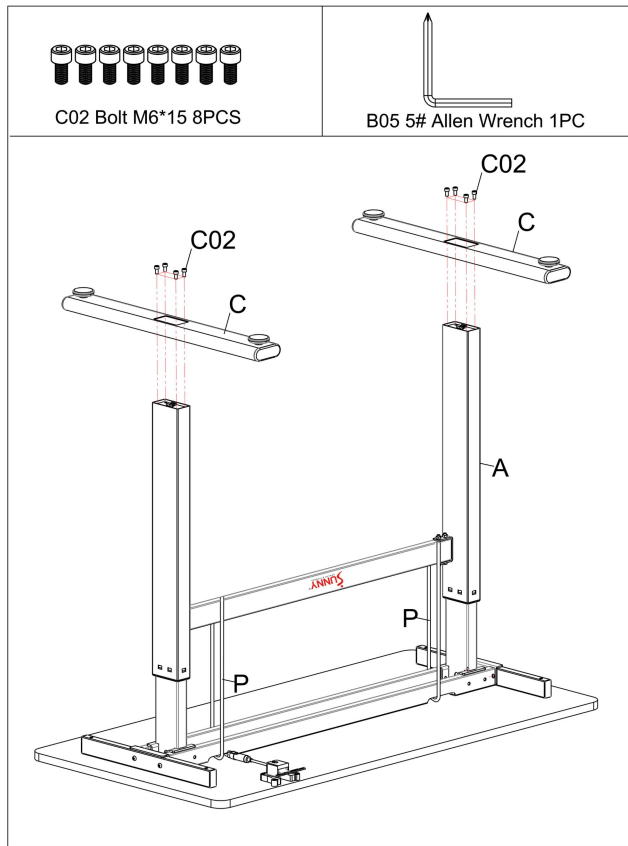

## STEP 2:

Attach the 2 **Foot Tube Sets (No. C)** to the **Main Frame (No. A)** by using 8 **Bolts (No. C02)**. Tighten with **5# Allen Wrench (No. B05)**.



## STEP 3:

Turn the desk right side up.

You may now cut the 2 **Packing Belts (No. P)** and discard.

*The assembly is completed!*

# HOW TO ADJUST THE DIRECTION

## How to Raise the Table Board

Move the **Lifting Wrench (No. D02)** upward with your right hand and hold it. Then use your left hand to lift the **Table Board (No. E01)**, the **Table Board (No. E01)** will rise. To stop the **Table Board (No. E01)** from rising, release the **Lifting Wrench (No. D02)**. The maximum height the **Table Board (No. E01)** can rise to is 47.2 inch. Based on that, you can choose any height you feel comfortable with.

## How to Press Down the Table Board

Move the **Lifting Wrench (No. D02)** upward with your right hand and hold it. Then press down slightly left hand at the center of the **Table Board (No. E01)**, the **Table Board (No. E01)** will begin to drop down. To stop the **Table Board (No. E01)** from dropping down, release the **Lifting Wrench (No. D02)**. The minimum height of desktop can drop down to is 29.5 inch.

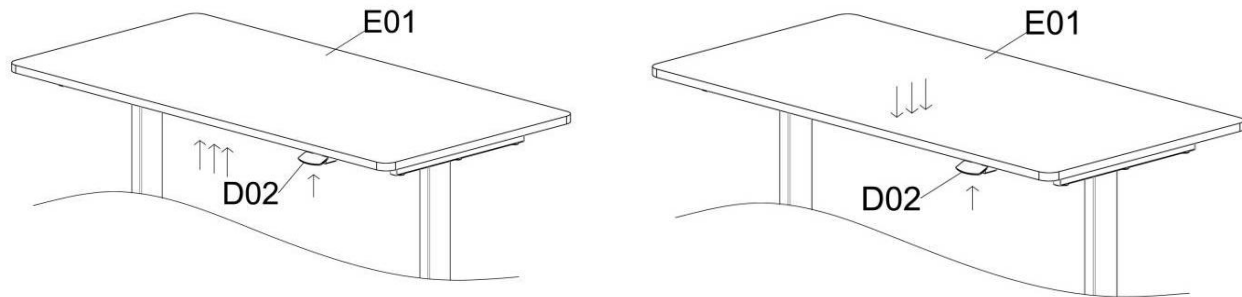

# HOW TO ADJUST THE BALANCE

If you find that the lift table is unbalanced, you can adjust the balance by using the 4 **Pad Adjustments (No. D07)**. Adjust the 4 **Pad Adjustments (No. D07)** clockwise to raise the height of footpad, and counter-clockwise to lower the height of footpad.

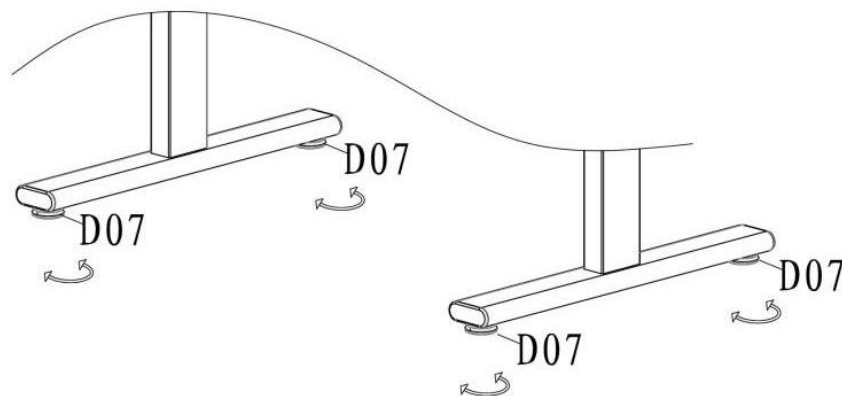



# EXPLODED DIAGRAM

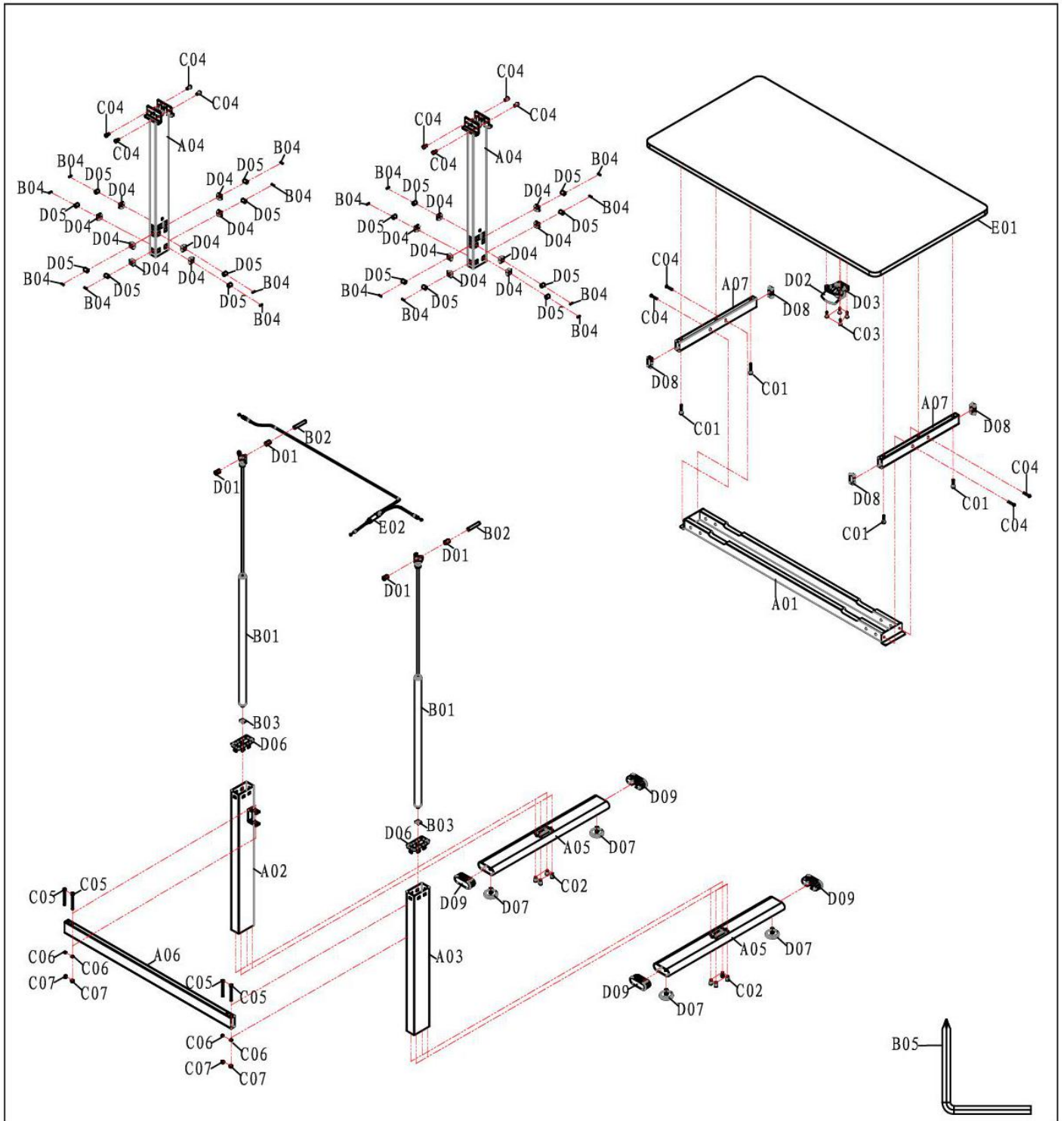

# PARTS LIST

No.	Description	Specification	Qty.
A01	Table Bracket		1
A02	Left Outer Upright Tube		1
A03	Right Outer Upright Tube		1
A04	Inner Upright Tube		2
A05	Foot Tube		2
A06	Connection Tube		1
A07	Table Rack Cross Tube		2
B01	Gas Spring		2
B02	Gas Spring Fixed Shaft		2
B03	Gas Spring Stuck Piece		2
B04	Roller Shaft		16
B05	5# Allen Wrench		1
C01	Bolt	M6*50	4
C02	Bolt	M6*15	8
C03	Screw	ST4.2*25	4

No.	Description	Specification	Qty.
C04	Bolt	M6*25	12
C05	Bolt	M6*70	4
C06	Washer	6	4
C07	Lock Nut	M6	4
D01	Sleeve		4
D02	Lifting Wrench		1
D03	Wrench Bracket		1
D04	Roller Frame		16
D05	Roller		16
D06	Slide Bushing		2
D07	Pad Adjustment		4
D08	Rectangular Plug		4
D09	Oval Plug		4
E01	Table Board		1
E02	Wire Rope		1

Version 1.0

# CONNECT WITH US

FOR FITNESS  
ARTICLES, VIDEOS  
& WORKOUTS



@SUNNYHEALTHANDFITNESS



@SUNNYHEALTHFITNESS



@SUNNYHEALTHFIT



/SUNNYHEALTHFITNESS



/SUNNYHEALTHANDFITNESS



@SUNNYHEALTHFITNESS

[WWW.SUNNYHEALTHFITNESS.COM](http://WWW.SUNNYHEALTHFITNESS.COM)