

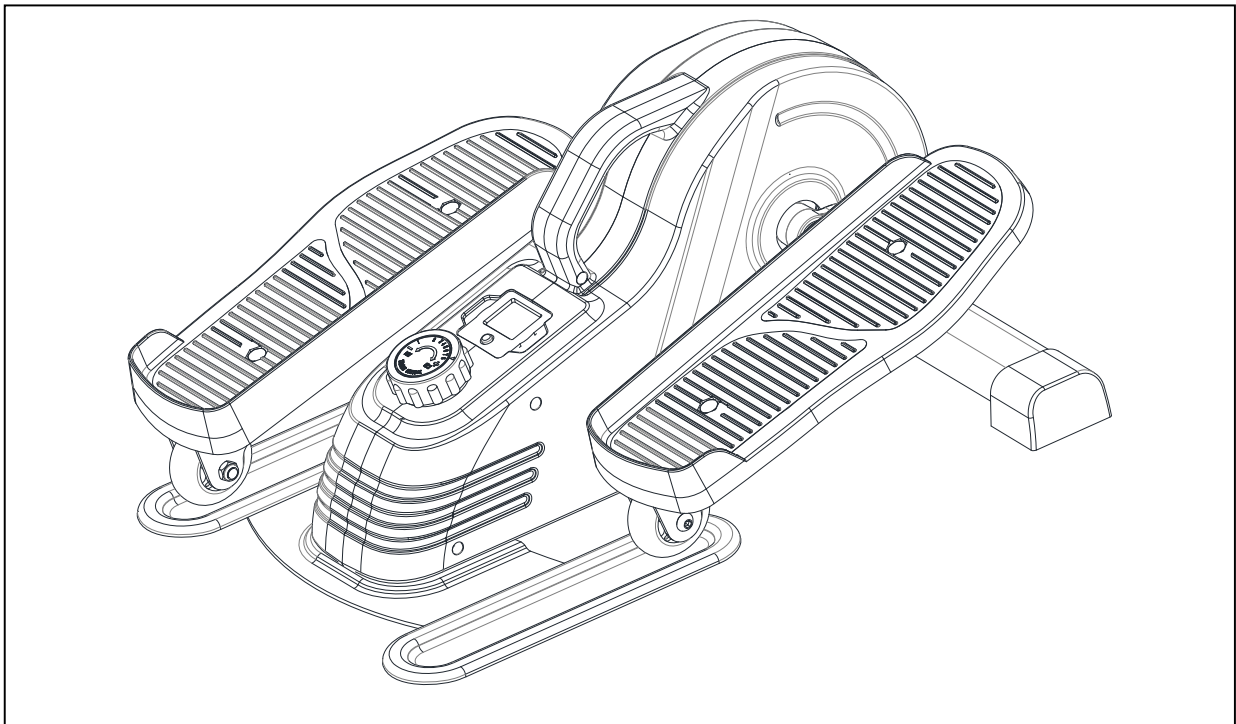

PINK UNDER DESK ELLIPTICAL MACHINE

P2030

USER MANUAL



IMPORTANT! Please retain owner's manual for maintenance and adjustment instructions. Your satisfaction is very important to us, **PLEASE DO NOT RETURN UNTIL YOU HAVE CONTACTED US:** support@sunnyhealthfitness.com or 1- 877 - 90SUNNY (877-907-8669).



WWW.SUNNYHEALTHFITNESS.COM

IMPORTANT SAFETY INFORMATION

We thank you for choosing our product. To ensure your safety and health, please use this equipment correctly. It is important to read this entire manual before assembling and using the equipment. Safe and effective use can only be achieved if the equipment is assembled, maintained, and used properly. It is your responsibility to ensure that all users of the equipment are informed of all warnings and precautions.

1. Before starting any exercise program, you should consult your physician to determine if you have any medical or physical conditions that could put your health and safety at risk or prevent you from using the equipment properly. Your physician's advice is essential if you are taking medication that affects your heart rate, blood pressure, or cholesterol level.
2. Be aware of your body's signals. Incorrect or excessive exercise can damage your health. Stop exercising if you experience any of the following symptoms: pain, tightness in your chest, irregular heartbeat, shortness of breath, lightheadedness, dizziness, or feelings of nausea. If you do experience any of these conditions, you should consult your physician before continuing with your exercise program.
3. Keep children and pets away from the equipment. The equipment is designed for adult use only.
4. Use the equipment on a solid, flat level surface with a protective cover for your floor or carpet. To ensure safety, the equipment should have at least 2 feet (60 CM) of free space all around it.
5. Ensure that all nuts and bolts are securely tightened before using the equipment. The safety of the equipment can only be maintained if it is regularly examined for damage and/or wear and tear.
6. Always use the equipment as indicated. If you find any defective components while assembling or checking the equipment, or if you hear any unusual noises coming from the equipment during exercise, discontinue use of the equipment immediately and do not use until the problem has been rectified.
7. Wear suitable clothing while using the equipment. Avoid wearing loose clothing that may become entangled in the equipment.
8. Do not place fingers or objects into the moving parts of the equipment.
9. The equipment is not suitable for therapeutic use.
10. To avoid bodily injury and/or damage to the product or property, proper lifting and moving are required.
11. Your product is intended for use in cool and dry conditions. You should avoid storage in extreme cold, hot or damp areas as this may lead to corrosion and other related problems.
12. This equipment is designed for indoor and home use only; it is not intended for commercial use.

IMPORTANT NOTE: Please remove the plastic tab from the meter before use!

EXPLODED DIAGRAM

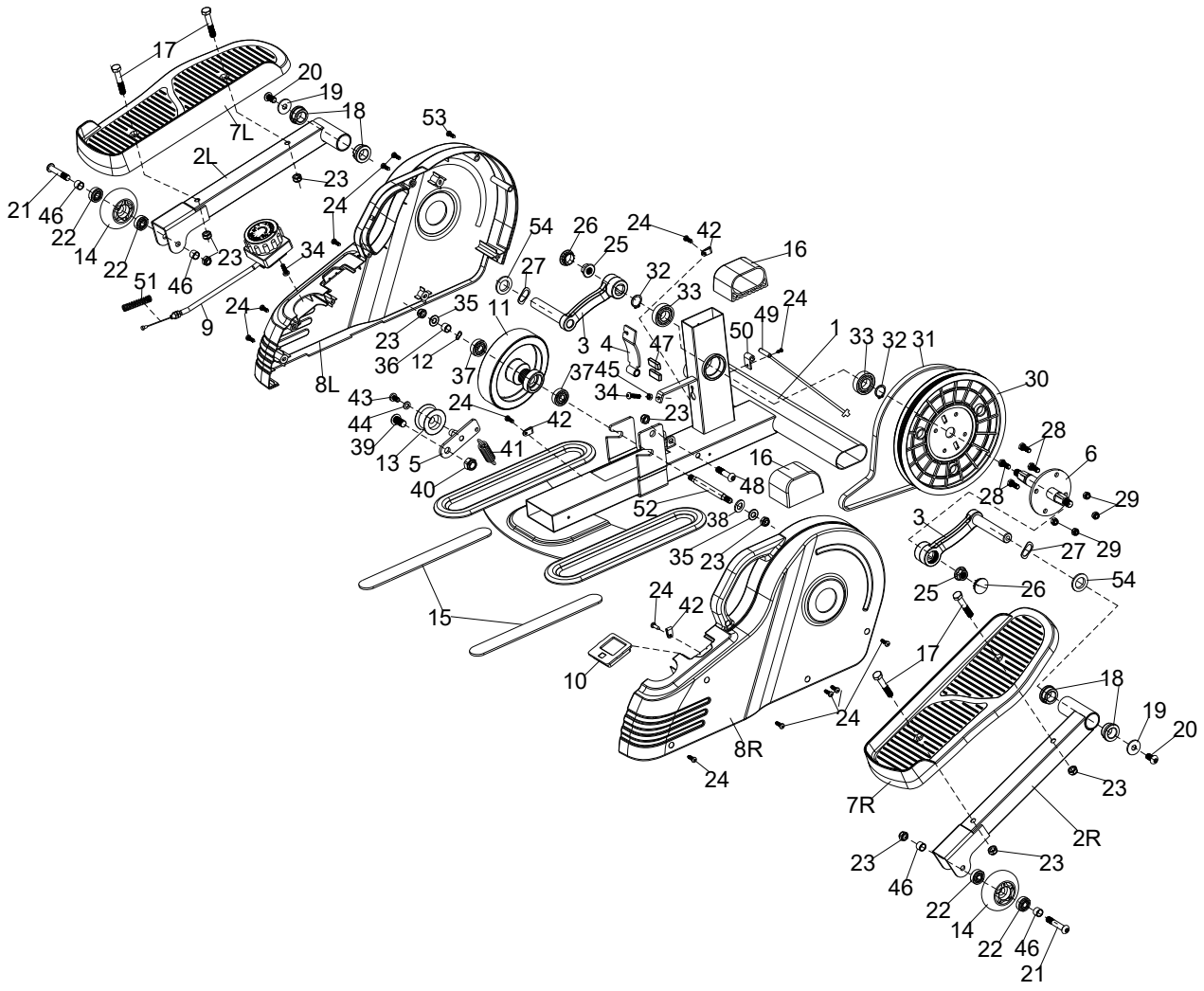

PARTS LIST

No.	Description	Spec.	Qty	No.	Description	Spec.	Qty
1	Main Frame		1	28	Bolt	M6*12	4
2R	Pedal Frame (R)		1	29	Nylon Nut	M6	4
2L	Pedal Frame (L)		1	30	Belt Wheel		1
3	Crank		2	31	Belt	J300	1
4	Magnetic Board		1	32	C-clip		2
5	Idler Wheel Shaft		1	33	Bearing	6003	2
6	Axle for Crank		1	34	Screw	M5*15	2
7L/R	Pedal		2	35	Flat Washer	Φ8.2*Φ16*1.5	2
8L/R	Belt Cover		2	36	Sleeve		1
9	Tension Control Knob		1	37	Bearing	6000	2
10	Meter		1	38	Washer	Φ10.2*Φ20*1.5	1
11	Inertial Wheel		1	39	Screw	M10*20*12	1
12	Wave Washer		1	40	Nylon Nut	M10	1
13	Idler Wheel		1	41	Spring		1
14	Slide Wheel		2	42	Wire Clip		3
15	Silicone Pad		2	43	Screw	M6*12	1
16	End Cap		2	44	Flat Washer	Φ6.4*Φ12*1.2	1
17	Bolt	M8*45*15	4	45	Nut	M5	1
18	Alloy Wrap		4	46	Sleeve		4
19	Flat Washer	Φ8.2*Φ25*1.5	2	47	Magnet		2
20	Screw	M8*16	2	48	Bolt	M8*35*15	1
21	Hex Bolt	M8*45*15	2	49	Inductor		1
22	Bearing		4	50	Inductor Seat		1
23	Nylon Nut	M8	9	51	Spring		1
24	Screw	ST4.2*15	14	52	Spindle		1
25	Flange Nut	M10	2	53	Screw	ST3.5*15	1
26	End Cap		2	54	Flat Washer	Φ16.2xΦ28x1.2	2
27	Rubber Washer		2				

Ordering Replacement Parts (U.S. and Canadian Customers only)

Please provide the following information in order for us to accurately identify the part(s) needed:

- ✓ The model number (found on cover of manual)
- ✓ The product name (found on cover of manual)
- ✓ The part number found on the “EXPLODED DIAGRAM” and “PARTS LIST” (found near the front of the manual)

Please contact us at support@sunnyhealthfitness.com or 1- 877 - 90SUNNY (877-907-8669).

BATTERY REPLACEMENT

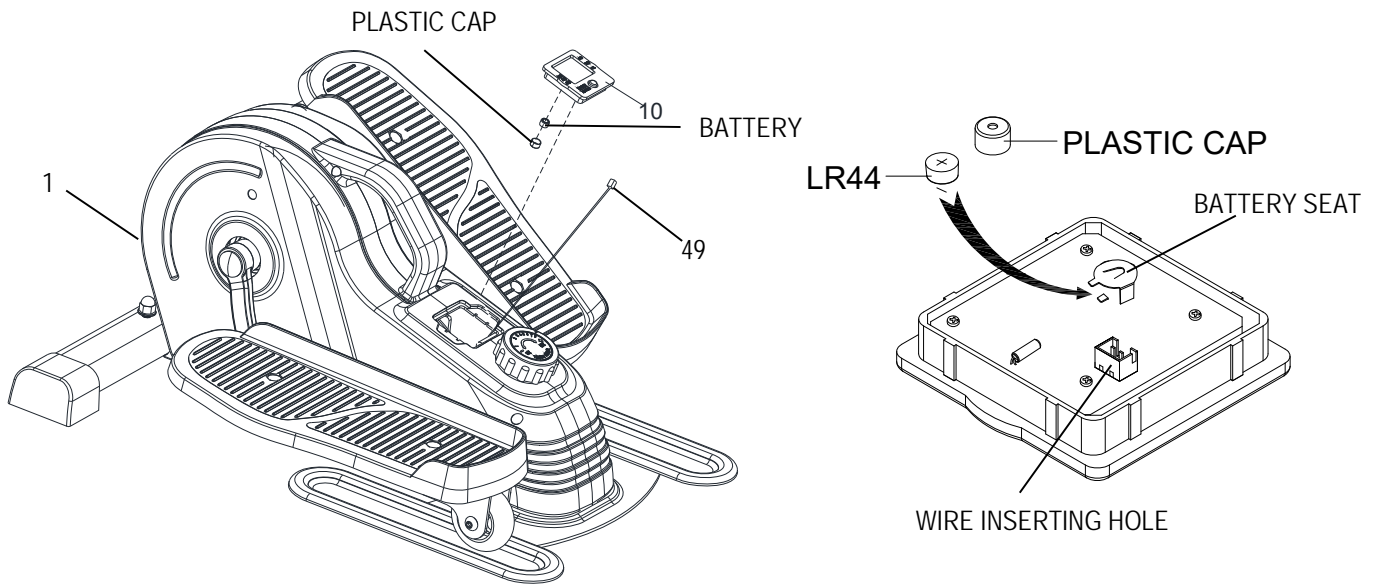

1. Remove the **Meter (No. 10)** from **Main Frame (No. 1)**. Then disconnect the link wire of **Inductor (No. 49)** with the **Meter (No. 10)**.
2. Remove the plastic cap from the back of **Meter (No. 10)**.
3. Insert the battery and ensure that the positive side of the battery, which is labeled with a + sign, is facing outward as shown in diagram above.
4. Put the plastic cap back onto the battery seat.
5. Insert the link wire of **Inductor (No. 49)** into the jack hole on the back of **Meter (No. 10)**.
6. Attach the **Meter (No. 10)** onto **Main Frame (No. 1)**.

The replacement is complete!

NOTE: Dispose battery according to your state and regional guidelines.

EXERCISE METER

SPECIFICATIONS

SPEED-----	0.0~999.9 MPH (Miles Per Hour)
TIME -----	0:00~99:59 MIN (Minutes)
DISTANCE-----	0.0~9999 ML (Miles)
CALORIES-----	0.0~9999 KCAL (Kilocalories)

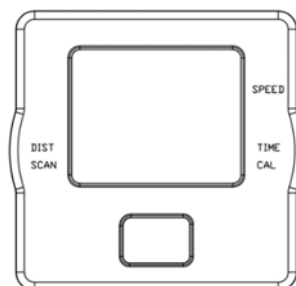

FUNCTION KEYS:

MODE: Press the red key repeatedly to select the desired value (Time, Speed, Distance, Calories, Scan). Hold the key for 4 seconds to have all function values reset (total reset).

FUNCTIONS:

- SPEED:** Displays current speed.
- TIME:** Displays the total time of the exercise from start to finish.
- DISTANCE:** Displays the distance of the exercise from start to finish.
- CALORIES:** Displays the total calories burned during an exercise from start to finish.
- SCAN:** Displays functions automatically in the following order: TIME, CALORIES and DISTANCE.

NOTE:

1. Please use 1pc of BUTTON CELL LR44 1.5V battery as a power supply. If there is an abnormal display on the meter, please replace the battery.
2. The meter will automatically power on when pedals are in motion or the MODE key is being pressed.
3. The meter will automatically start calculating when exercise begins.
4. All functions will automatically stop calculating with a "STOP" sign on the upper left corner of the meter when there is no movement for about 4 seconds; "STOP" sign will be off and the meter will automatically start calculating as soon as the machine is in motion.
5. The meter will automatically shut off if there is no movement for 4 to 5 minutes.

ADJUSTMENTS & USAGE GUIDE

	<p>ADJUSTING THE TENSION</p> <p>Adjust the tension by rotating the Tension Control Knob (No. 9) <i>clockwise</i> to increase the level of resistance. Rotate the Tension Control Knob (No. 9) <i>counter-clockwise</i> to decrease the level of resistance.</p> <p>Tension levels are set at Level 1 being the lowest and Level 8 being the highest.</p>
 <p>USE ONLY WHILE SITTING. DO NOT STAND ON THE ELLIPTICAL!</p>	<p>WARNING</p> <p>The elliptical is intended to use in a sitting position only, do not stand on the elliptical.</p> <p>Failure to follow all warnings and instructions could result in serious injury or death.</p>
 <p>Plastic Tab</p>	<p>IMPORTANT NOTE:</p> <p>Please remove the plastic tab from the meter before use!</p>

CONNECT WITH US

FOR FITNESS
ARTICLES, VIDEOS
& WORKOUTS



@SUNNYHEALTHANDFITNESS



@SUNNYHEALTHFITNESS



@SUNNYHEALTHFIT



/SUNNYHEALTHFITNESS



/SUNNYHEALTHANDFITNESS

WWW.SUNNYHEALTHFITNESS.COM