

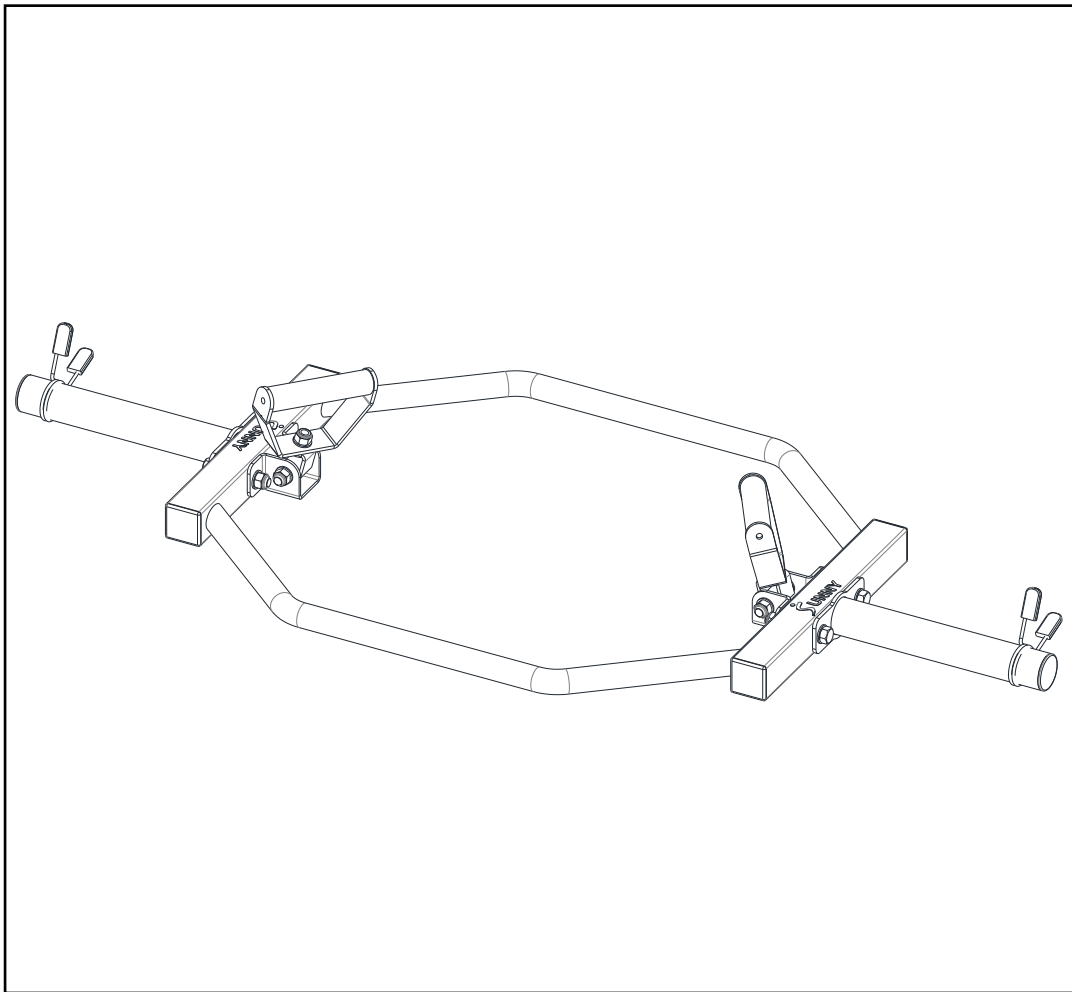

HEX TRAP BAR, 2-INCH DIAMETER SLEEVE OB-TRAP USER MANUAL



IMPORTANT! Please retain owner's manual for maintenance and adjustment instructions. Your satisfaction is very important to us, **PLEASE DO NOT RETURN UNTIL YOU HAVE CONTACTED US:** support@sunnyhealthfitness.com or 1- 877 - 90SUNNY (877-907-8669).



WWW.SUNNYHEALTHFITNESS.COM

IMPORTANT SAFETY INFORMATION



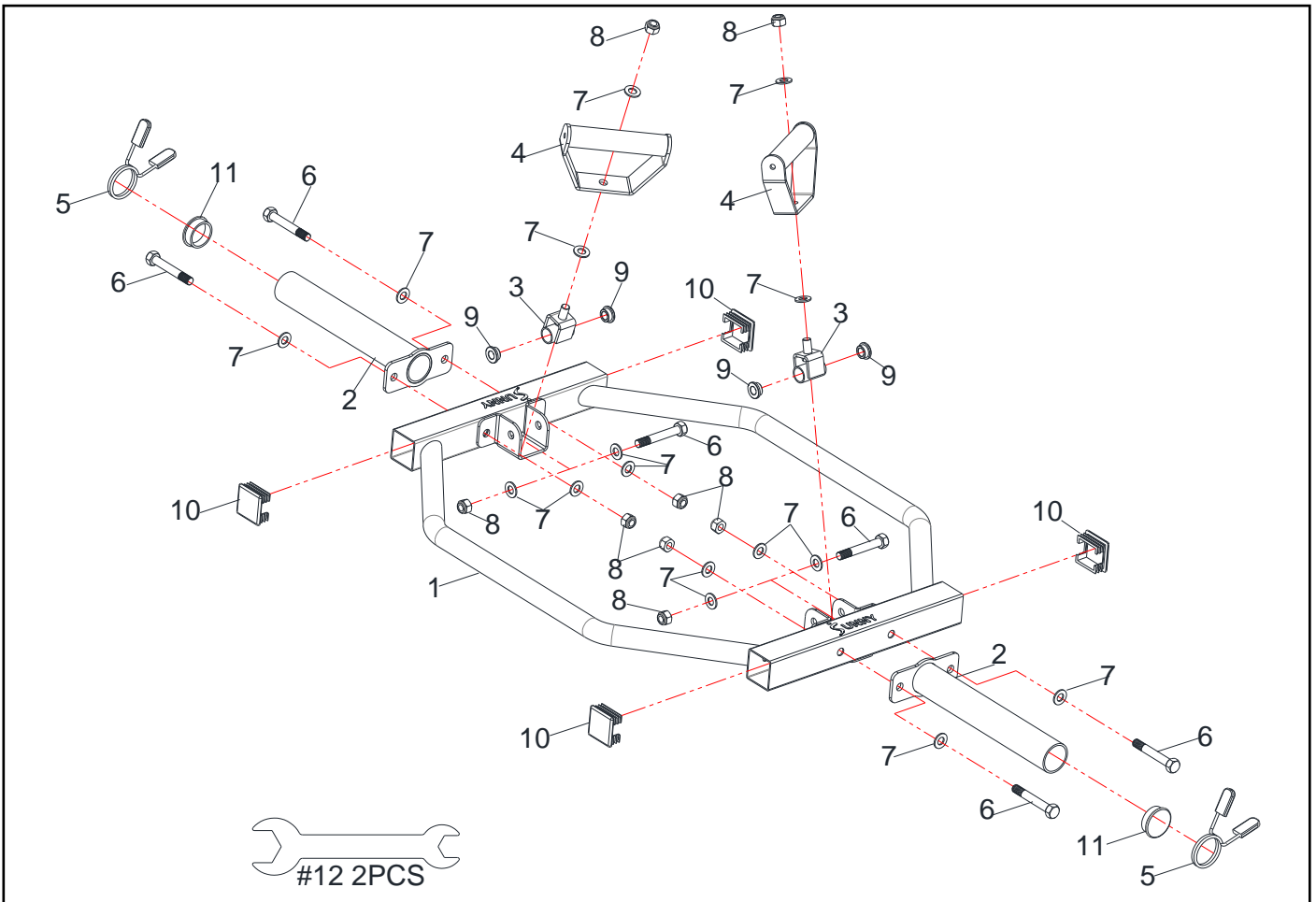

We thank you for choosing our product. To ensure your safety and health, please use this equipment correctly. It is important to read this entire manual before assembling and using the equipment. Safe and effective use can only be achieved if the equipment is assembled, maintained, and used properly. It is your responsibility to ensure that all users of the equipment are informed of all warnings and precautions.

1. Before starting any exercise program, you should consult your physician to determine if you have any medical or physical conditions that could put your health and safety at risk or prevent you from using the equipment properly. Your physician's advice is essential if you are taking medication that affects your heart rate, blood pressure, or cholesterol level.
2. Be aware of your body's signals. Incorrect or excessive exercise can damage your health. Stop exercising if you experience any of the following symptoms: pain, tightness in your chest, irregular heartbeat, shortness of breath, lightheadedness, dizziness, or feelings of nausea. If you do experience any of these conditions, you should consult your physician before continuing with your exercise program.
3. Keep children and pets away from the equipment. The equipment is designed for adult use only.
4. Use the equipment on a solid, flat level surface with a protective cover for your floor or carpet. To ensure safety, the equipment should have at least 2 feet (60 CM) of free space all around it.
5. Ensure that all nuts and bolts are securely tightened before using the equipment. The safety of the equipment can only be maintained if it is regularly examined for damage and/or wear and tear.
6. Always use the equipment as indicated. If you find any defective components while assembling or checking the equipment, or if you hear any unusual noises coming from the equipment during exercise, discontinue use of the equipment immediately and do not use until the problem has been rectified.
7. Wear suitable clothing while using the equipment. Avoid wearing loose clothing that may become entangled in the equipment.
8. Do not place fingers or objects into the moving parts of the equipment.
9. The maximum weight capacity of this unit is 400 pounds (180KG).
10. The equipment is not suitable for therapeutic use.
11. To avoid bodily injury and/or damage to the product or property, proper lifting and moving are required.
12. Your product is intended for use in cool and dry conditions. You should avoid storage in extreme cold, hot or damp areas as this may lead to corrosion and other related problems.
13. This equipment is designed for indoor and home use only; it is not intended for commercial use.

EXPLODED DIAGRAM



HARDWARE PACKAGE

	#6-M12*80mm 4PCS	
	#8-M12 4PCS	
	#7- ϕ 24* ϕ 12.5*2.0mm 8PCS	
		#12-#17-19 2PCS

PARTS LIST

No.	Description	Spec.	Qty.
1	Support Frame		1
2	Weight Plate Holder		2
3	Multi Connection Tube		2
4	Handlebar		2
5	Spring Clip	φ 48	2
6	Hex Bolt	M12*80mm	6

No.	Description	Spec.	Qty.
7	Flat Washer	φ 24* φ 12.5*2.0mm	16
8	Lock Nut	M12	8
9	Alloy Wrap	φ 25* φ 12.5*10	4
10	Square End Cap	50*50*2.0	4
11	Round End Cap	φ 48*2.0	2
12	Wrench	#17-19	2

Ordering Replacement Parts (U.S. and Canadian Customers only)

Please provide the following information in order for us to accurately identify the part(s) needed:

- ✓ The model number (found on cover of manual)
- ✓ The product name (found on cover of manual)
- ✓ The part number found on the “EXPLODED DIAGRAM” and “PARTS LIST” (found near the front of the manual)

Please contact us at support@sunnyhealthfitness.com or 1- 877 - 90SUNNY (877-907-8669).

ASSEMBLY INSTRUCTIONS

We value your experience using Sunny Health and Fitness products. For assistance with parts or troubleshooting, please contact us at support@sunnyhealthfitness.com or 1-877-90SUNNY (877-907-8669).

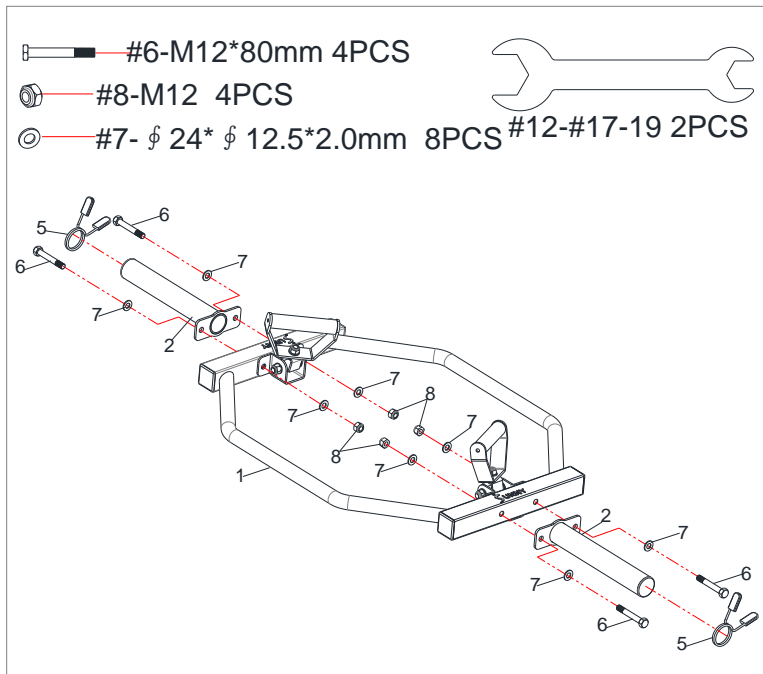

STEP 1:

Attach 2 **Weight Plate Holders (No. 2)** to the **Support Frame (No. 1)** using 4 **Hex Bolts (No. 6)**, 8 **Flat Washers (No. 7)** and 4 **Lock Nuts (No. 8)**. Tighten and secure with 2 **Wrenches (No. 12)**.

NOTE: Be sure to use the **Spring Clips (No. 5)** on the **Weight Plate Holders (No. 2)** to secure weight plates.

The assembly is complete!

MAINTENANCE INSTRUCTIONS

DAILY MAINTENANCE

Inspect and tighten all parts regularly. (Nuts, Bolts, Rubber Pads, Steel Brackets, etc.)

Replace any worn or torn parts immediately.

Check and ensure the equipment is leveled at all time.

Check and tighten all adjustment pins/knobs regularly.

WEEKLY MAINTENANCE

Use damp cloth on plastic parts only, use dry cloth on metal frames.

Inspect the metal frame structure of the equipment.

CONNECT WITH US

FOR FITNESS
ARTICLES, VIDEOS
& WORKOUTS



@SUNNYHEALTHANDFITNESS



@SUNNYHEALTHFITNESS



@SUNNYHEALTHFIT



/SUNNYHEALTHFITNESS



/SUNNYHEALTHANDFITNESS

WWW.SUNNYHEALTHFITNESS.COM