

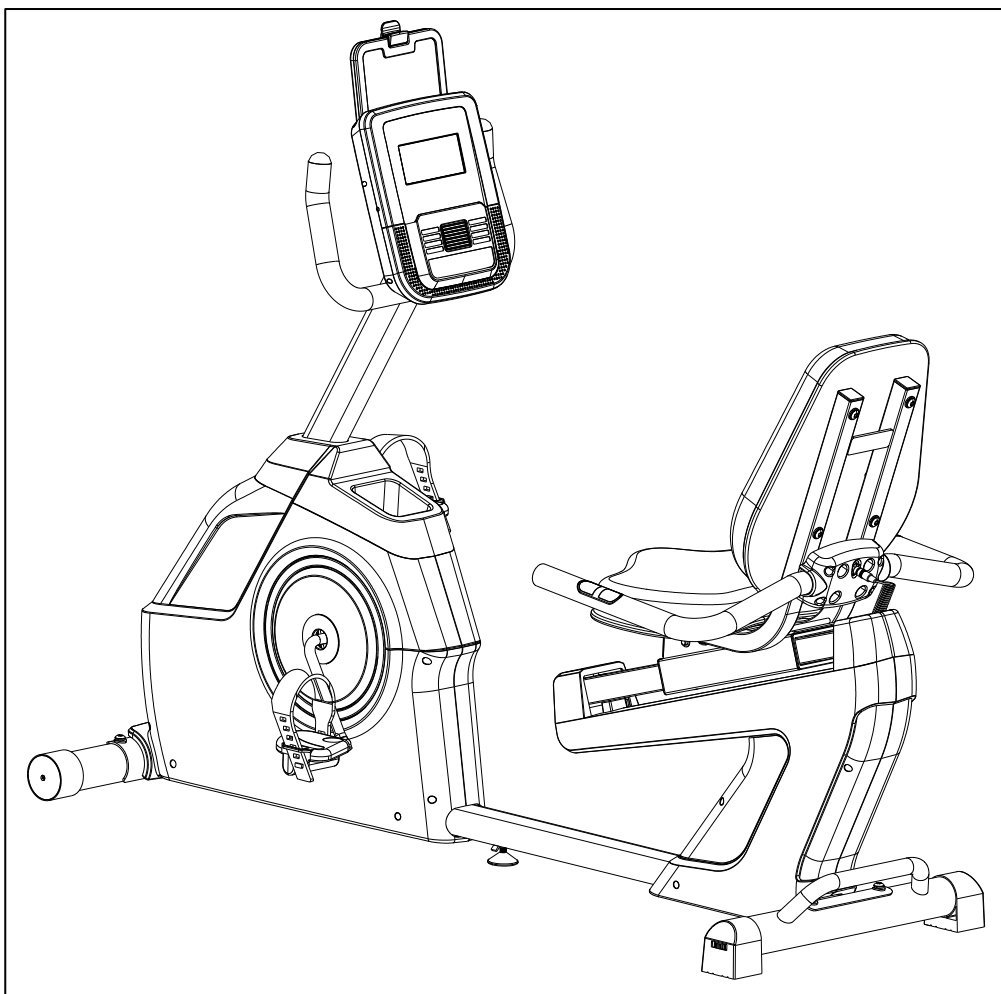

EVO-FIT CARDIO RECUMBENT BIKE

SF-RB4954

USER MANUAL



IMPORTANT! Please retain owner's manual for maintenance and adjustment instructions. Your satisfaction is very important to us, **PLEASE DO NOT RETURN UNTIL YOU HAVE CONTACTED US:** support@sunnyhealthfitness.com or 1-877-90SUNNY (877-907-8669).



WWW.SUNNYHEALTHFITNESS.COM

IMPORTANT SAFETY INFORMATION

We thank you for choosing our product. To ensure your safety and health, please use this equipment correctly. It is important to read this entire manual before assembling and using the equipment. Safe and effective use can only be achieved if the equipment is assembled, maintained and used properly. It is your responsibility to ensure that all users of the equipment are informed of all warnings and precautions.

1. Before starting any exercise program, you should consult your physician to determine if you have any medical or physical conditions that could put your health and safety at risk, or prevent you from using the equipment properly. Your physician's advice is essential if you are taking medication that affects your heart rate, blood pressure or cholesterol level.
2. Be aware of your body's signals. Incorrect or excessive exercise can damage your health. Stop exercising if you experience any of the following symptoms: pain, tightness in your chest, irregular heartbeat, shortness of breath, lightheadedness, dizziness or feelings of nausea. If you do experience any of these conditions, you should consult your physician before continuing with your exercise program.
3. Keep children and pets away from the equipment. The equipment is designed for adult use only.
4. Use the equipment on a solid, flat level surface with a protective cover for your floor or carpet. To ensure safety, the equipment should have at least 2 feet (60 CM) of free space all around it.
5. Ensure that all nuts and bolts are securely tightened before using the equipment. The safety of the equipment can only be maintained if it is regularly examined for damage and/or wear and tear.
6. Always use the equipment as indicated. If you find any defective components while assembling or checking the equipment, or if you hear any unusual noises coming from the equipment during exercise, discontinue use of the equipment immediately and do not use until the problem has been rectified.
7. Wear suitable clothing while using the equipment. Avoid wearing loose clothing that may become entangled in the equipment.
8. Do not place fingers or objects into the moving parts of the equipment.
9. The maximum weight capacity of this unit is 300 pounds (135 KG).
10. The equipment is not suitable for therapeutic use.
11. To avoid bodily injury and/or damage to the product or property, proper lifting and moving is required.
12. Your product is intended for use in cool, dry conditions. You should avoid storage in extreme cold, hot or damp areas as this may lead to corrosion and other related problems.
13. This equipment is designed for indoor and home use only, it is not intended for commercial use!

EXPLODED DIAGRAM

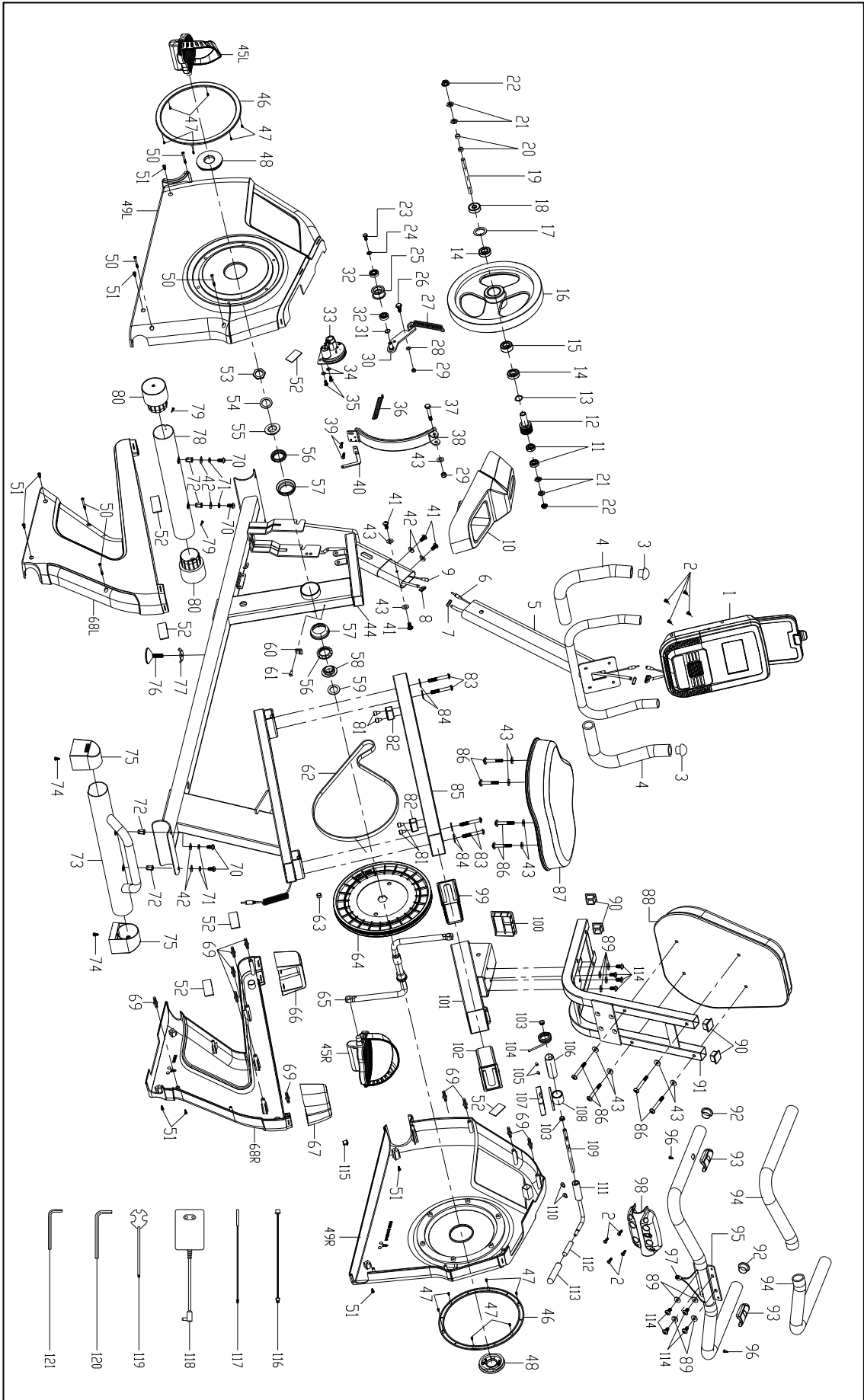

PARTS LIST

No.	Description	Spec.	Qty.
1	Console		1
2	Screw	M5x12L	8
3	Round Cap		2
4	Foam Grip		2
5	Handlebar Post		1
6	Sensor Wire 1		1
7	Sensor Wire 2		1
8	Sensor Wire 3		1
9	Sensor Wire 4		1
10	Upright Tube Cover		1
11	Bearing	6900	2
12	Belt Pulley	Φ30	1
13	Washer	Φ17.5xΦ22x0.3T	1
14	Bearing	6003 2RS	2
15	Bearing	Φ35x17	1
16	Flywheel	Φ260x35Wx3.5KG	1
17	Flat Washer	Φ30xΦ34x0.8T	1
18	Bearing	6300 2RS	1
19	Flywheel Spindle	3/8"-26x130L	1
20	Plastic Sleeve	Φ10xΦ15.8x6mm	2
21	Hex Nut	3/8"-26x3.8T	4
22	Nut	3/8"-26x7T	2
23	Screw	M6x10L	1
24	Flat Washer	Φ6.5xΦ13x2T	1
25	Idler Wheel		1
26	Screw	M8x20L	1
27	Spring	Φ16xΦ2.5	1
28	Flat Washer	Φ8xΦ22x1T	1
29	Nylon nut	M8x7T	2
30	Idler Wheel Linkage		1
31	Washer	Φ10.2xΦ13x0.3T	1
32	Bearing	6000 2ZZ	2
33	Motor		1

No.	Description	Spec.	Qty.
34	Flat Washer	Φ5.5xΦ12x2T	2
35	Hex Screw	M5xP0.8x12L	2
36	Spring	Φ1xΦ8.5x48L	1
37	Hex Screw	M8xP1.25x55LxS17	1
38	Magnetic Board		1
39	Screw	M5x10L	2
40	Gear Case Support		1
41	Screw	M8x12L	4
42	Washer	Φ8xΦ19x2T	6
43	Flat Washer	Φ8xΦ19x2T	11
44	Main Frame		1
45L/R	Pedal		2
46	Decorative Cover		2
47	Screw	ST2.9*8L	12
48	Crank Cover		2
49L/R	Belt Cover		2
50	Screw	ST3.9x50L	5
51	Screw	3/16"*3/4"	8
52	Eva Cushion	25x45x2T	6
53	Hex Nut	BC7/8"x24UnF-LH	1
54	Washer	35x23x2T	1
55	Nut	BC7/8"x24UnF-LH	1
56	Open Face Bearing	5/16"x12	2
57	Bearing Housing	51.5x46.2x16.2	2
58	Nut	BC15/16"x24UnF-RH	1
59	Washer	Φ37.5xΦ26.2x0.8T	1
60	Fixed Mount		1
61	Screw	ST4.2x16L	1
62	Belt	430 J6	1
63	Magnetic Core		1
64	Belt Pulley	Φ289	1
65	Crank	190Wx170	1
66	Slide Track Cover 1		

No.	Description	Spec.	Qty.
67	Slide Track Cover 2		1
68L/ R	Slide Track L/R Cover		2
69	Fixed Bar		10
70	Screw	M8x25L	4
71	Washer	Φ8.5xΦ13.5x2.5T	4
72	Pull Rod	M8x18L	4
73	Rear Stabilizer		1
74	Washer	ST4.2x19L	2
75	End Cap		2
76	Adjustable Pad		1
77	Lock Sheet		1
78	Front Stabilizer		1
79	Screw	ST2.9x8L	2
80	End Cap		2
81	Screw	M6x20L	4
82	Limited Pad		2
83	Screw	M8xP1.25x56LxS 20L	4
84	Flat washer	Φ8.5xΦ25x2T	4
85	Seat Slide Rail		1
86	Screw	M8x50L	8
87	Seat		1
88	Backrest		1
89	Flat Washer	Φ8xΦ16x2T	8
90	Tube Plug		4
91	Backrest Tube		1
92	Tube Plug		2
93	Hand Pulse Sensor		2
94	Handlebar Foam		2

No.	Description	Spec.	Qty.
95	Handlebar		1
96	Screw	ST3.5x20L	2
97	Pulse Wire		1
98	Handlebar Cover		1
99	Seat Post Bushing		1
100	Seat Post Plug		1
101	Slip Tube		1
102	Seat Post Bushing		1
103	Handle Shaft Sleeve		2
104	Handle Spring		1
105	Screw	M6x1.0x16L	2
106	Eccentric Shaft		1
107	Friction Plate		1
108	Briquetting		1
109	Regulating Stem		1
110	Screw	M6x8L	2
111	Adjustment Handle		1
112	Hand Shank		1
113	Handle Sleeve		1
114	Screw	M8x16L	8
115	Wire Plug		1
116	DC Wire		1
117	Sensor Wire 5		1
118	Adaptor		1
119	Spanner	S13,15,19	1
120	Allen Wrench	S6	1
121	Allen Wrench	S5	1

HARDWARE PACKAGE

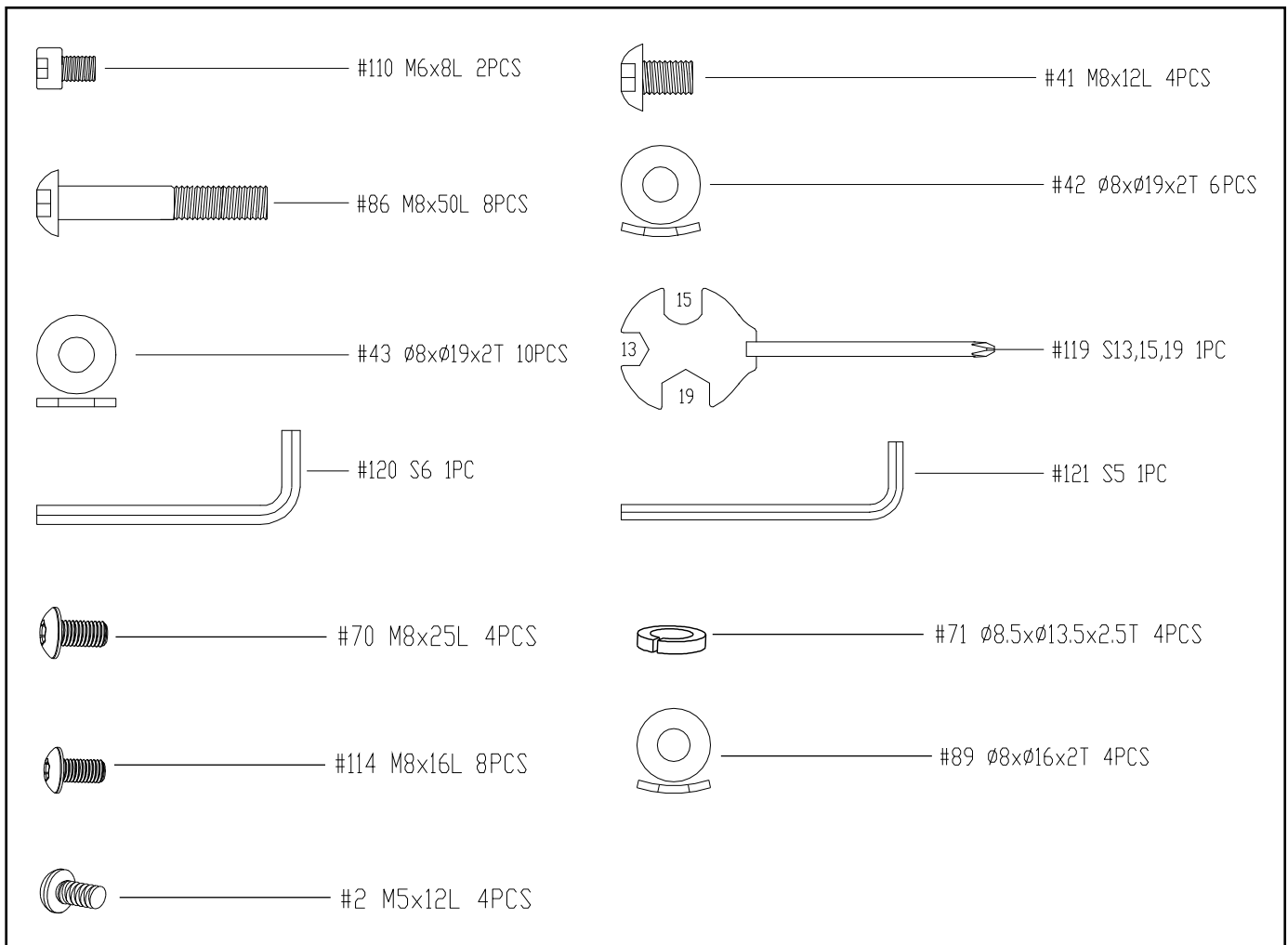

Ordering Replacement Parts (U.S. and Canadian Customers only)

Please provide the following information in order for us to accurately identify the part(s) needed:

- ✓ The model number (found on cover of manual)
- ✓ The product name (found on cover of manual)
- ✓ The part number found on the “EXPLODED DIAGRAM” and “PARTS LIST” (found near the front of the manual)

Please contact us at support@sunnyhealthfitness.com or 1- 877 - 90SUNNY (877-907-8669).

ASSEMBLY INSTRUCTIONS

We value your experience using Sunny Health and Fitness products. For assistance with parts or troubleshooting, please contact us at support@sunnyhealthfitness.com or 1-877-90SUNNY (877-907-8669).

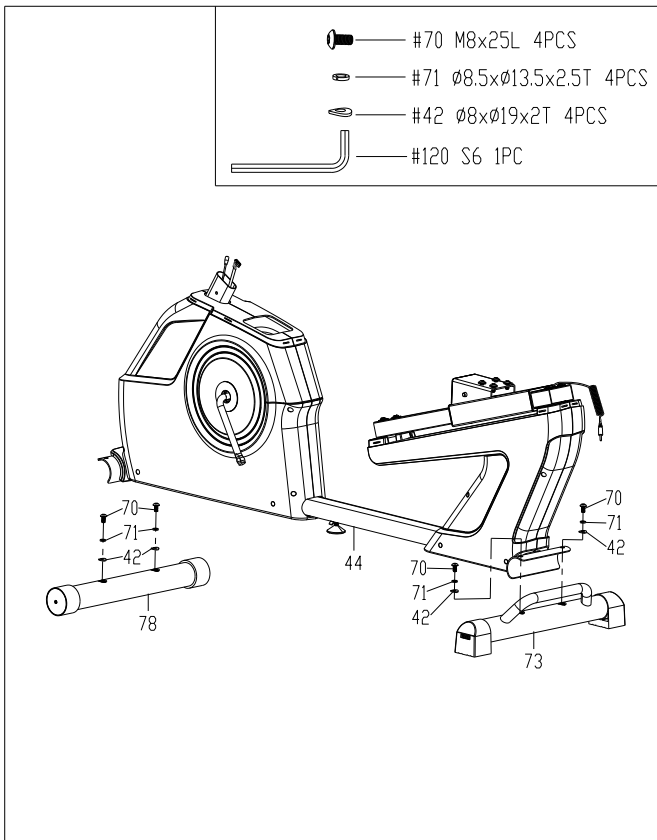

STEP 1:

Remove the preassembled 4 **Screws (No. 70)**, 4 **Washers (No. 71)** and 4 **Washers (No. 42)** from **Front & Rear Stabilizers (No. 78 & 73)** using **Allen Wrench (No. 120)**.

Attach **Front & Rear Stabilizers (No. 78 & 73)** to **Main Frame (No. 44)** with 4 **Screws (No. 70)**, 4 **Washers (No. 71)** and 4 **Washers (No. 42)**. Tighten and secure with **Allen Wrench (No. 120)**.

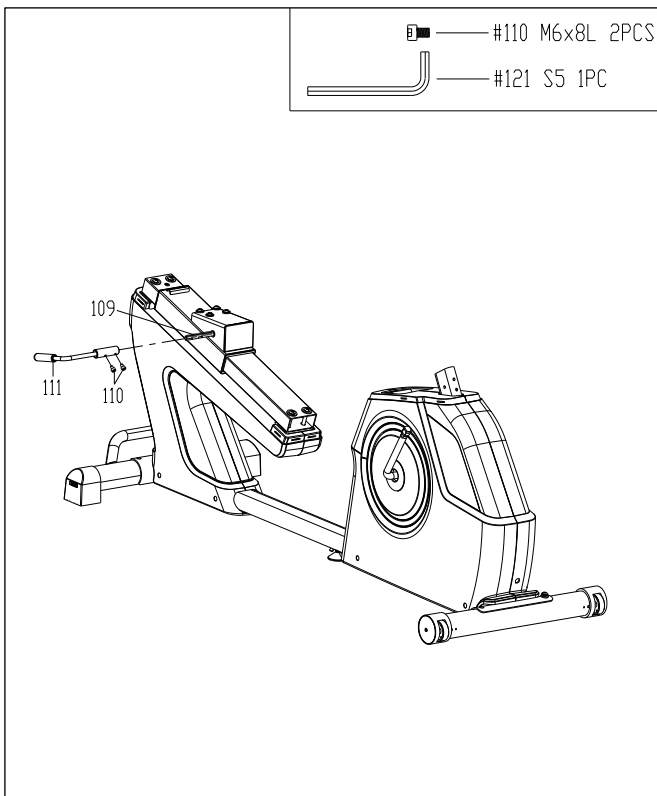

STEP 2:

Insert **Adjustment Handle (No. 111)** to **Regulating Steam (No. 109)**. Align the 2 holes in **Adjustment Handle (No. 111)** to the plane of the **Regulating Steam (No. 109)**. Tighten and secure with 2 **Screws (No. 110)** using **Allen Wrench (No. 121)**.

We value your experience using Sunny Health and Fitness products. For assistance with parts or troubleshooting, please contact us at support@sunnyhealthfitness.com or 1-877-90SUNNY (877-907-8669).

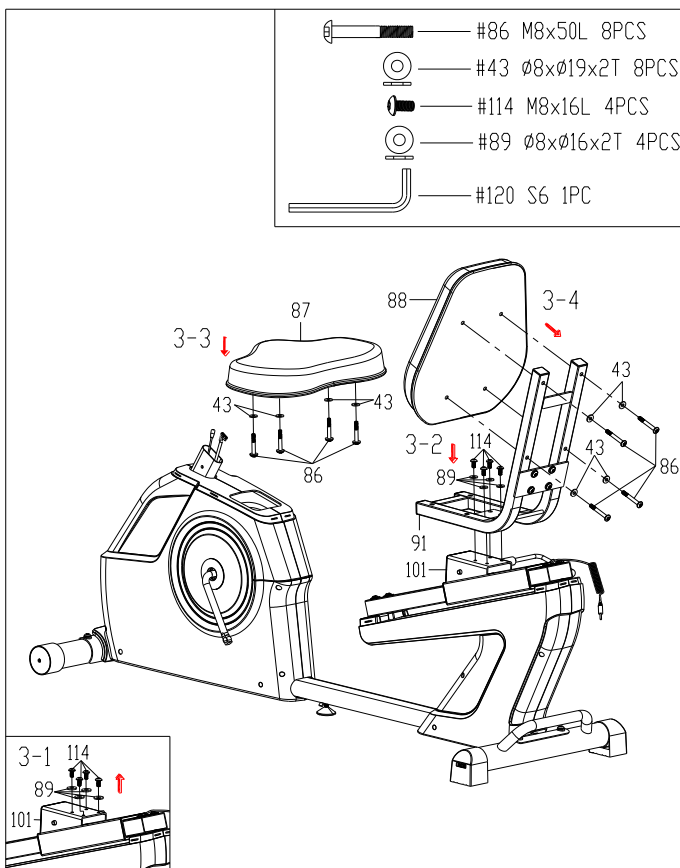

STEP 3:

3-1: Remove the preassembled 4 **Screws (No. 114)** and 4 **Flat Washers (No. 89)** from the **Slip Tube (No. 101)** using **Allen Wrench (No. 120)**.

3-2: Attach the **Backrest Tube (No. 91)** to **Slip Tube (No. 101)** with 4 **Screws (No. 114)** and 4 **Flat Washers (No. 89)** using **Allen Wrench (No. 120)**.

3-3: Attach the **Seat (No. 87)** to **Backrest Tube (No. 91)** with 4 **Screws (No. 86)** and 4 **Flat Washer (No. 43)** using **Allen Wrench (No. 120)**.

3-4: Attach the **Backrest (No. 88)** to **Backrest Tube (No. 91)** with 4 **Screws (No. 86)** and 4 **Flat Washer (No. 43)** using **Allen Wrench (No. 120)**.

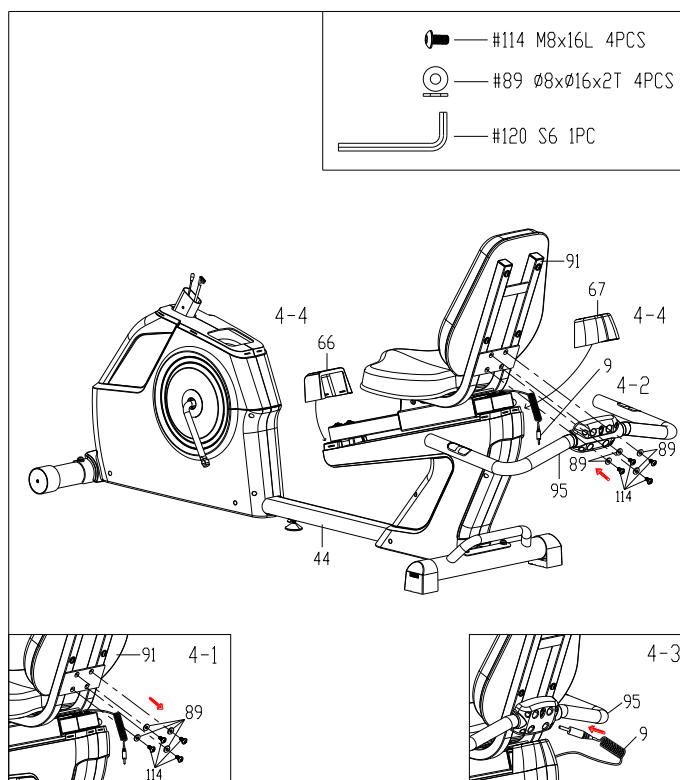

STEP 4:

4-1: Remove the preassembled 4 **Screws (No. 114)** and 4 **Flat Washers (No. 89)** from the **Backrest Tube (No. 91)** using **Allen Wrench (No. 120)**.

4-2: Attach the **Handlebar (No. 95)** to **Backrest Tube (No. 91)** with 4 **Screws (No. 114)** and 4 **Flat Washers (No. 89)** using **Allen Wrench (No. 120)**.

4-3: Insert the **Sensor Wire 4 (No. 9)** into the jack of the **Handlebar (No. 95)**.

4-4: Insert the **Slide Track Covers 1 & 2 (No. 66 & 67)** to the **Main Frame (No. 44)**.

We value your experience using Sunny Health and Fitness products. For assistance with parts or troubleshooting, please contact us at support@sunnyhealthfitness.com or 1-877-90SUNNY (877-907-8669).

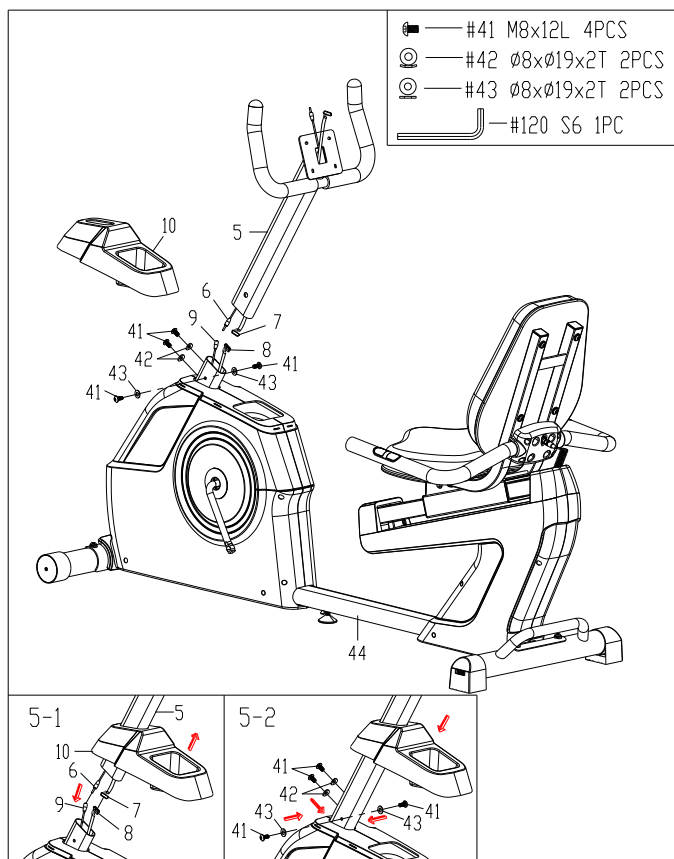

STEP 5:

NOTE: Do not pinch or cut any wires when inserting the **Handlebar Post (No. 5)** into the **Main Frame (No. 44)**.

5-1: Insert the **Upright Tube Cover (No. 10)** into the **Handlebar Post (No. 5)**. Move the **Upright Tube Cover (No. 10)** higher. Connect **Sensor Wire 1 (No. 6)** with **Sensor Wire 4 (No. 9)**, and connect **Sensor Wire 2 (No. 7)** with **Sensor Wire 3 (No. 8)**. Insert all wires into the **Handlebar Post (No. 5)**. Once completed, insert the **Handlebar Post (No. 5)** into the **Main Frame (No. 44)**.

5-2: Attach the **Handlebar Post (No. 5)** to the **Main Frame (No. 44)** with 4 **Screws (No. 41)**, 2 **Washers (No. 42)** and 2 **Flat Washers (No. 43)** by **Allen Wrench (No. 120)**. Move the **Upright Tube Cover (No. 10)** down until it snaps into the **Main Frame (No. 44)**.

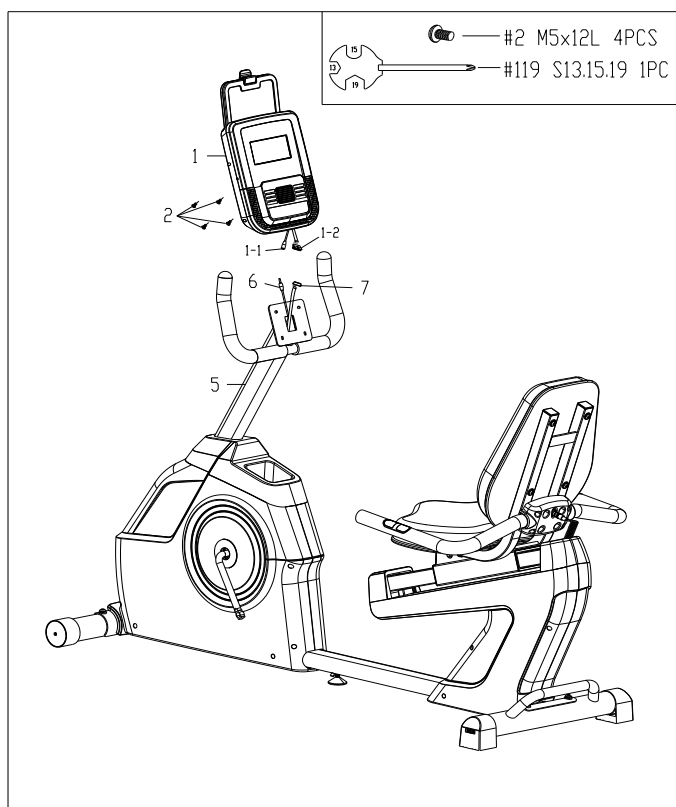

STEP 6:

NOTE: Do not pinch or cut any wires when attaching the **Console (No. 1)** to the **Handlebar Post (No. 5)**.

Remove the 4 **Screws (No. 2)** from the back of **Console (No. 1)** by **Spanner (No. 119)**.

Connect the console wire 1-1 with **Sensor Wire 1 (No. 6)**, and connect the console wire 1-2 with **Sensor Wire 2 (No. 7)**. Insert all wires into the tube for **Handlebar Post (No. 5)**.

Attach the **Console (No. 1)** to the **Handlebar Post (No. 5)** with the 4 **Screws (No. 2)** by **Spanner (No. 119)**.

We value your experience using Sunny Health and Fitness products. For assistance with parts or troubleshooting, please contact us at support@sunnyhealthfitness.com or 1-877-90SUNNY (877-907-8669).

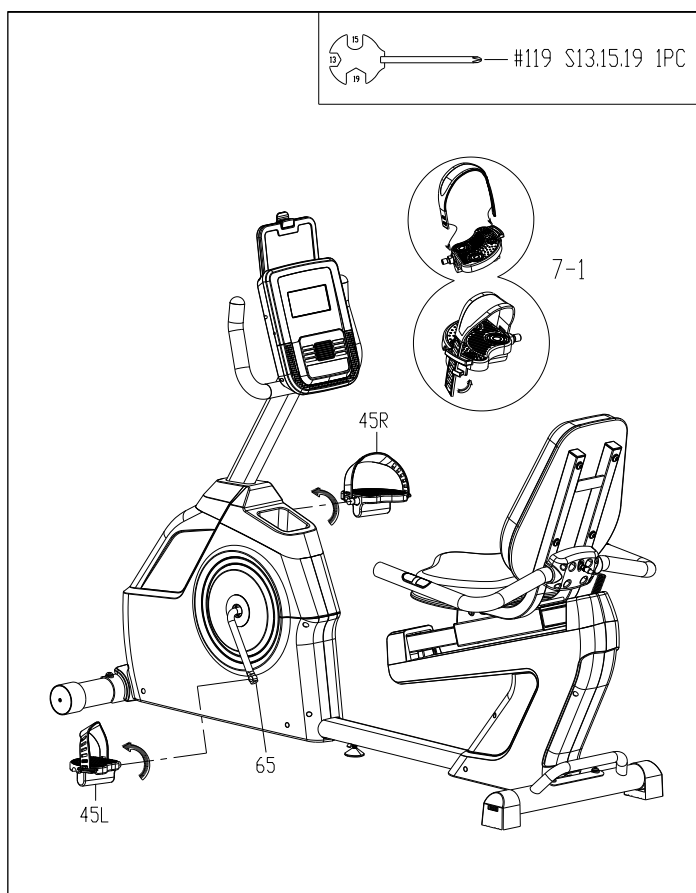

STEP 7:

7-1: Put the pedal straps into the 2 Pedals (No. 45L/R). Attach the 2 Pedals (No. 45L/R) to the Crank (No. 65) by Spanner (No. 119).

NOTE: Make sure to attach the **Left Pedal (No. 45L)**, marked (L), to the **Left Crank (No. 65)**. It should be tightened *counter-clockwise*. Make sure to attach the **Right Pedal (No. 45R)**, marked (R), to the **Right Crank (No. 65)**. It should be tightened *clockwise*.

Attaching the **Pedals (No. 45L/R)** to the wrong **Crank (No. 65)** or turning them the wrong direction will damage the **Crank (No. 65)**.

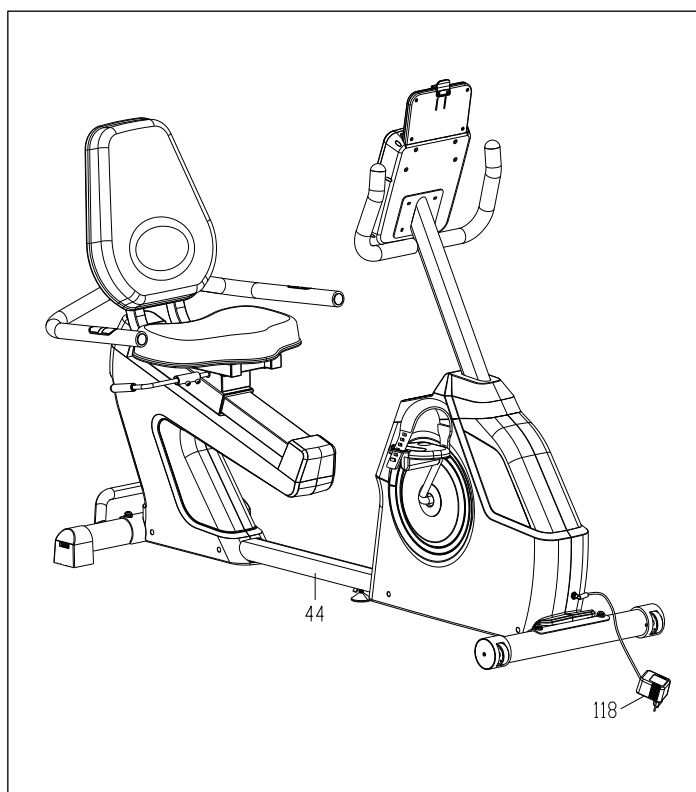

STEP 8:

Connect the **Adaptor (No. 118)** to the **Main Frame (No. 44)**.

Assembly is now complete!

ADJUSTMENT GUIDE

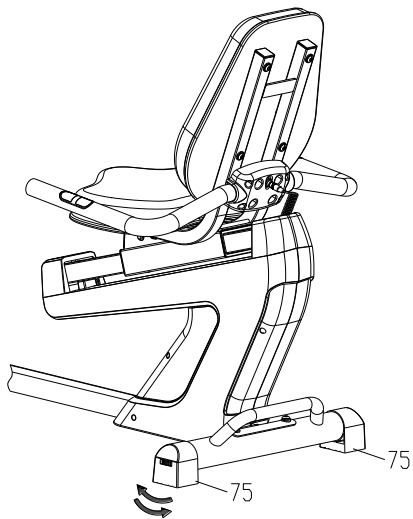

ADJUSTING THE LEVEL

If the bike is not level, turn the dials on the **End Caps (No. 75)** to adjust. Turn *counter-clockwise* to raise and turn *clockwise* to lower.

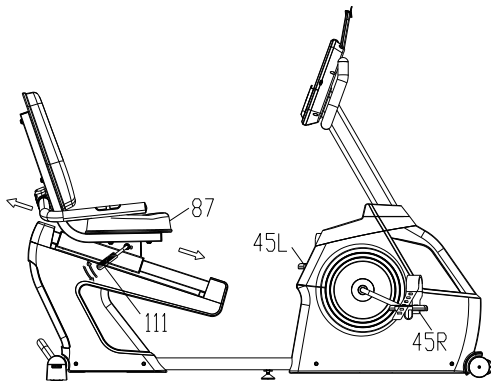

ADJUSTING THE SEAT

To move the **Seat (No. 87)** forward or backward, sit on the bike and place your feet on the **Pedals (No. 45L/R)**. Shift the **Adjustment Handle (No. 111)** down to loosen. Move the **Seat (No. 87)** to your desired position. Shift the **Adjustment Handle (No. 111)** up to secure.

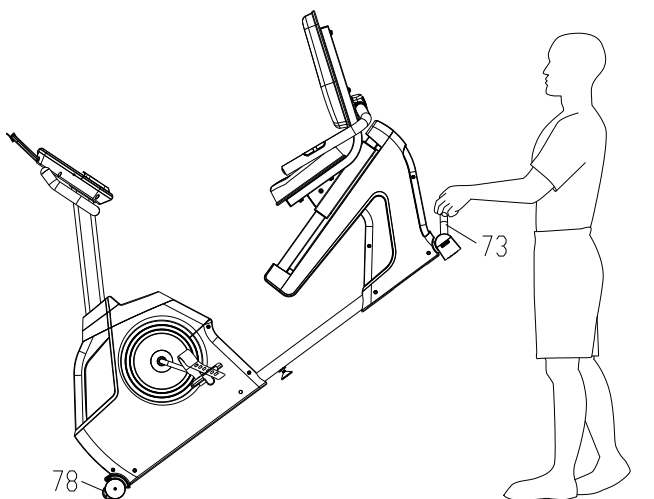

MOVING THE BIKE

There are wheels located on the **Front Stabilizer (No. 78)**. Hold the handlebar on the **Rear Stabilizer (No. 73)** and pull forward to lift the rear of the recumbent bike off the floor. Now you can move the recumbent bike.

IMPORTANT BIKE INFORMATION

WARNING: The Upright Bike requires a power source of **2.5 amps (100-240V)** in order to properly operate. For your safety, as well as the safety of others, please verify that the power source is correct before plugging in the equipment. Any power source above or below this level could cause significant damage to the equipment and or user.

OPERATING INSTRUCTIONS

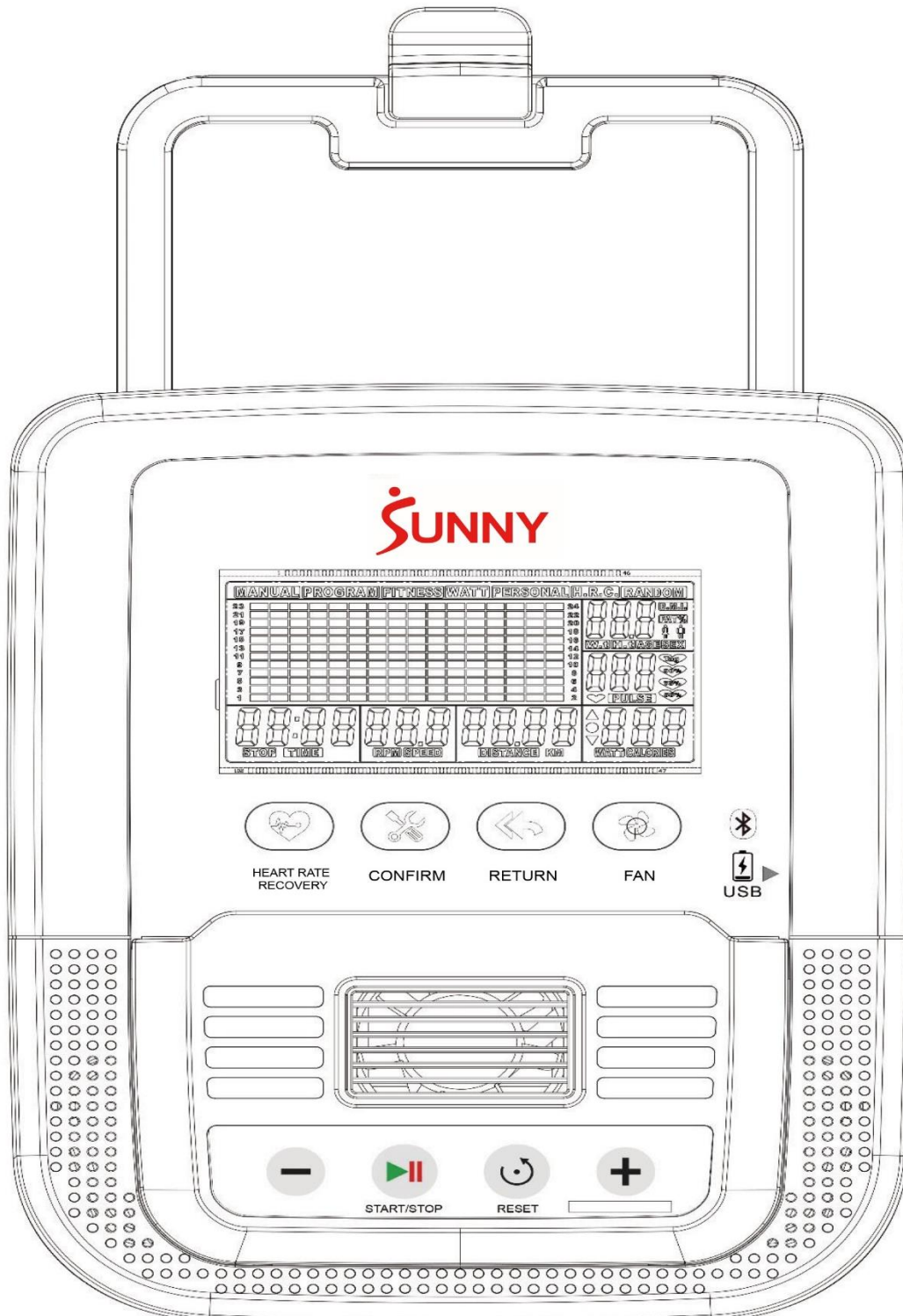

FUNCTION BUTTONS



Heart rate recovery key

After exercising, the console will go into Recovery Mode and display the user's heart rate value. Recovery displays F1-F6. F6 is poor heart rate recovery while F1 is excellent heart rate recovery.



Confirm key

During workout, use this key to switch and confirm each function. Long press this key to restart the console to Startup Mode.



Return key

During workout, press this key to return to the previous interface.



Fan key

Press this key turn the fan on and off.



Decrease key

Press this key to select functions or decrease function values (time/distance/calories/heart rate/resistance).



Start/Stop key

Press this key to start or stop exercise function.



Reset key

Set the user information for SEX, AGE, H.T (HEIGHT), W.T (WATT) for user interface (U0-U4), press this key to back to the original user interface. When in the workout mode selection interface, press this key to go back to the main menu. This key can also reset all function values when in Stop Mode.



Increase key

Press this key to select functions or increase function values (time/distance/calories/heart rate/resistance).

FUNCTIONS

TIME: Records total time from 00:00 ~ 99:59 mins. This function can count down the time to 0 when setting. The function value can be increased or decreased by increments of 1 min.

SPEED: Displays the speed from 0.0 ~ 99.9 MPH.

RPM: Displays the RPM from 0 ~ 15 ~ 999.

WATT: Displays the watts from 0 ~ 999. The setting range for watts is from 10 to 350.

DISTANCE: Records the total distance from 0.00 ~ 999.9 miles. This function can count down the distance to 0 when setting. The setting range for Distance is between 0.0 ~ 99.50 MPH. The value for Distance increases or decreases in increments of 0.5 mile/time.

CALORIES: Records total calories burned from 0 ~ 999 CAL. Counts down the calories to 0. The setting range for this feature is from 0 ~ 990 CAL. The value increases or decreases in increments of 10 CAL.

TEMPERATURE: Displays current temperature between 32~99°F(0 ~ 60°C) when the console is in sleep mode.

PULSE: Displays the current pulse rate of 0 ~ 40 ~ 240 BPM. The setting range for this feature is between 40 ~ 240 BPM.

HEART SYMBOL:  The symbol will flash fast or slow depending on the user's pulse wave.

Bluetooth function:

After the bike is turned on, turn on the Bluetooth function of your mobile device to connect with the Bluetooth on bike (Bluetooth model number: SUNNY). User can play music from their mobile device.

Fan function:

The user can press the fan key to turn the fan on or off.

USB charger:

The console comes with a USB charger for user's tablet or smart phone. Plug the cable into USB port for device charging (USB cable not included).

Automatic startup and shutdown:

When the user starts to pedal or presses any key, the console will automatically start up. The console will turn off if there is no signal input for 4 minutes. Press any key on the console to turn it on again.

Operation

1. After connecting the power, the console will enter Startup Mode. The buzzer will beep for 1 second and the LCD will display for 2 seconds. The console will display the wheel diameter value of 78. The console will then enter U0 window.
2. When in Startup Mode or pressing the reset key, the console will turn on. After the console is fully displayed, press the increase/decrease keys to select U0~U4, and enter by pressing the confirm key. Press the increase/decrease keys to set SEX, AGE, H.T (HEIGHT), W.T (WATT). Press the confirm key to set.
3. User can choose from the following workout modes by pressing the increase/decrease keys, then enter any modes by pressing the confirm key:

MANUAL / PROGRAM / FITNESS / WATT / PERSONAL / HEART RATE CONTROL (H.R.C)

MANUAL MODE

To select Manual Mode, press the confirm key. Press the increase/decrease keys to set the resistance and set by pressing the confirm key. Setting range for this is from levels 1 ~ 24. The value increases or decreases in increments of 1. Press the increase/decrease keys to select from the following: Time Countdown Mode, Distance Countdown Mode, Calorie Countdown Mode or Pulse Target Mode. During the workout, user can press the increase/decrease keys to adjust the resistance.

To set Countdown Mode:

1. In manual mode, press the confirm key to enter **Time Countdown Mode**. The time window will flash and display the time. The initial time is 01:00. Set countdown time by pressing the increase/decrease keys. Press the START button to start the exercise. If you do not press the START key and press the confirm key again, the bike will go into distance setting.

2. Press confirm key to enter **Distance Countdown Mode**. The initial distance is 0.00 MI. Set the distance by pressing the increase/decrease buttons. Press the START button to start the exercise. If you do not press the START button and press the confirm button again, the bike will go into calorie setting.
3. Press confirm key to enter **Calorie Countdown Mode**. The initial calorie will be displayed as 0 cal. Set the calories by pressing the increase/decrease button. Press the START button to start the exercise. If you do not press the START button and press the confirm button again, the bike will go into pulse setting.
4. Press confirm key to enter **Pulse Target Mode**. When exercising, the console will display the pulse. When the current pulse goes up to the target pulse value, the pulse value will flash. The initial pulse will be displayed as 0. Set the target pulse by pressing the increase/decrease keys. Press the START button to start the exercise. If you do not press the START button and press the confirm button, the bike will return to time setting.

PROGRAM MODE

P1 – P36 are programs with preset resistance. Each program is divided into 16 segments. Each segment is the same amount of time. Select PROGRAM MODE and press the confirm key to enter.

1. Press the increase/decrease keys to select pre-set program P1 – P36, then press the confirm key.
2. Press the increase/decrease keys to adjust the resistance value. Press the confirm button to set.
3. Press the increase/decrease keys to adjust the time.
4. Press the START button and the bike will work at the preset resistance of the selected program. (see details in below pictures).

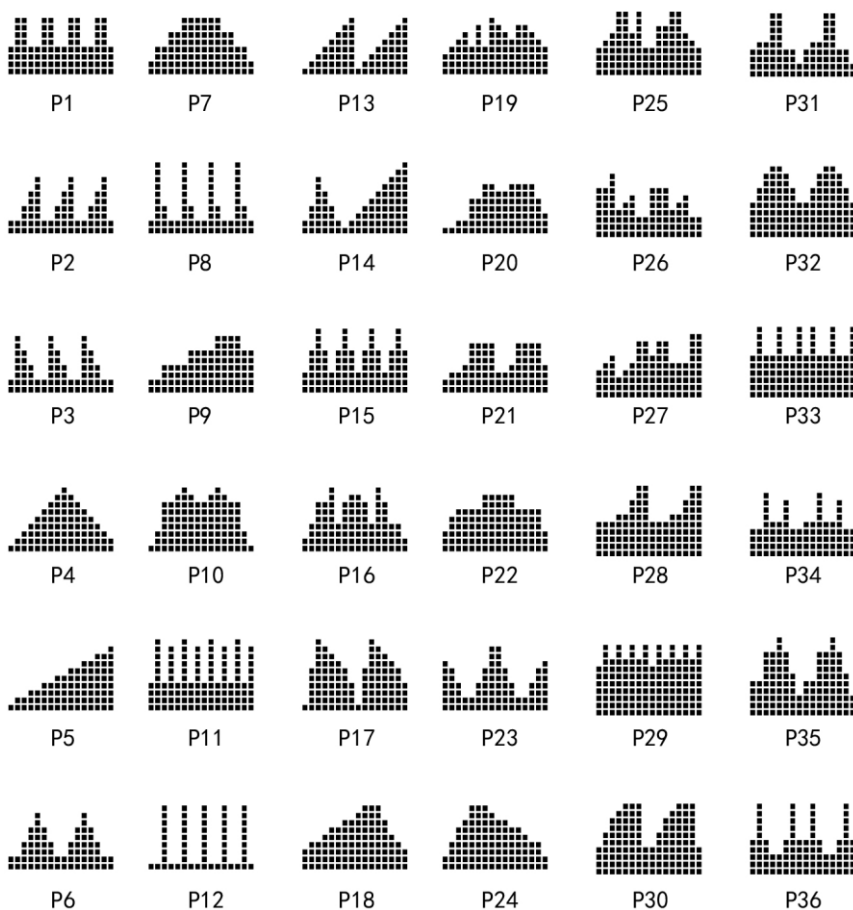

5. During exercise, the user can press the increase/decrease keys to adjust resistance.
6. Press STOP button to stop the bike.

FITNESS MODE

The fitness mode allows the user to exercise under a fixed time and resistance level. The fixed time is 12 minutes and the fixed resistance level is 6. To enter, select the FITNESS MODE and press the confirm key. Press the START button to initiate the exercise.

WATT CONSTANT

The console will adjust the resistance level automatically depending on the speed to maintain the constant watt value. To enter, select the WATT MODE and press the confirm key. Press the increase/decrease keys to set the values for watt, time, distance, calories or pulse. Press the START button to start the exercise. During the workout, user can press the increase/decrease keys to adjust the watt value.

PERSONAL PROGRAM

The personal programs allow the user to set their own program that can be used immediately. Each program is divided into 16 segments. Each segment is the same amount of time. To begin, select the PERSONAL MODE then press the confirm key to enter. Press the increase/decrease keys to set the resistance value for the 16 segments. Press the confirm key to confirm each setting.

1. Press and hold the confirm key for 2 seconds to enter time setting. The time window will flash.
2. Press START button to start the exercise.

H.R.C HEART RATE CONTROL

This function controls the exercise resistance according to the user's HEART RATE. If the user's pulse is above or below the below heart rate, the console will adjust the resistance level automatically. Select the H.R.C MODE and press the confirm key to set.

1. Press increase/decrease keys to choose heart rate and press the confirm key to set.
 - i. 55% -- Diet effect program
 - ii. 75% -- Health effects program
 - iii. 90% -- Exercise effect program
 - iv. Target heartbeat - self-training heartbeat
2. Press increase/decrease keys to set values for pulse, time, distance, calories. Then, press the confirm key to set.
3. Press START button to start the exercise.

Heart rate recovery:

When the console displays the heart rate value, press the Heart Rate recovery key. The console will begin to detect the user's pulse. The test time is a 1:00 min countdown. The heartbeat symbol will blink continuously until it reaches 0. User should hold the handle pulse sensors for 1 minute. The heartbeat symbol will keep flashing. When the time reaches 0, the console will display F1 ~ F6 recovery levels.

Level	User heartbeat recovery	Heartbeat detection gap (before and after test)
F1	Perfect	Mean difference 50
F2	Very good	40-49
F3	Normal	30-39
F4	Fair	20-29
F5	Need more exercise	10-19
F6	Inactivity	10 Below

NOTE: Under the heart rate recovery function, the console will display ERR1 the user's pulse cannot be detected.

NOTE:

1. Please insert Adaptor (**9 VOLT, 2.5A**) before using the bike.
2. This console should be kept away from all moisture.

CONNECT WITH US

FOR FITNESS
ARTICLES, VIDEOS
& WORKOUTS



@SUNNYHEALTHANDFITNESS



@SUNNYHEALTHFITNESS



@SUNNYHEALTHFIT



/SUNNYHEALTHFITNESS



/SUNNYHEALTHANDFITNESS

WWW.SUNNYHEALTHFITNESS.COM