

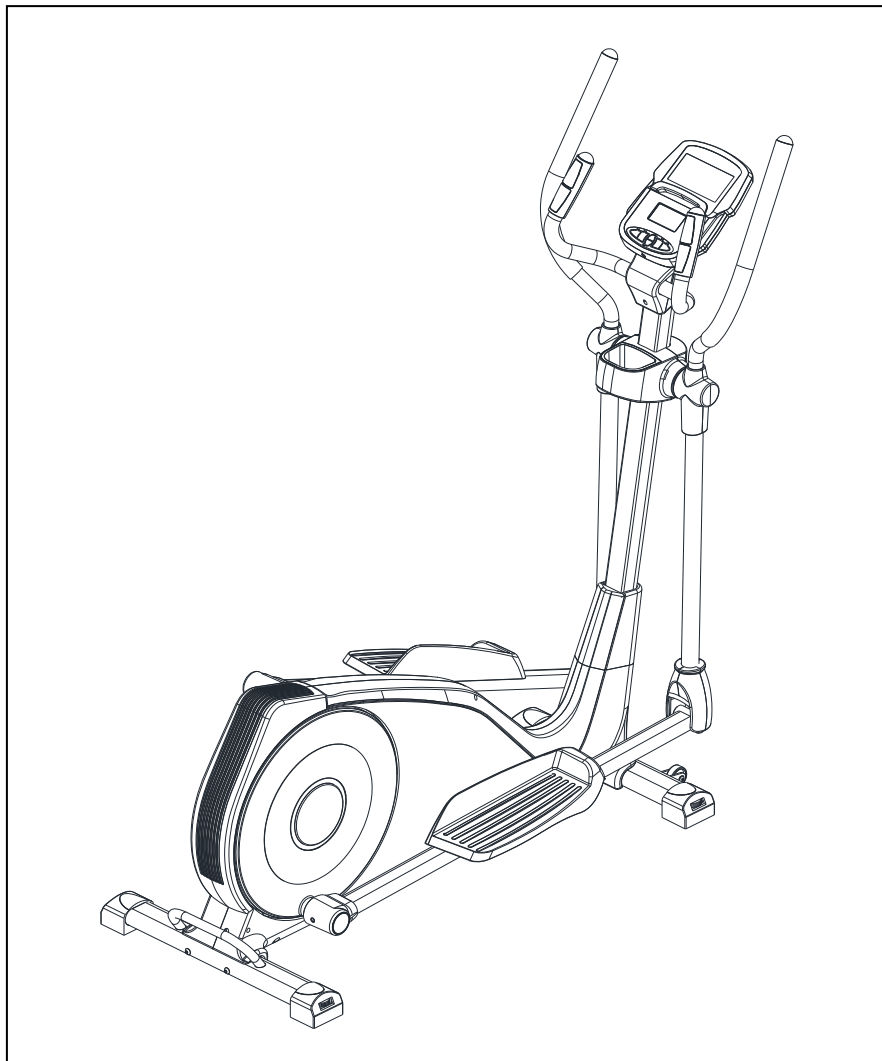

PRE-PROGRAMMED ELLIPTICAL TRAINER SF-E320001 USER MANUAL



IMPORTANT! Please retain owner's manual for maintenance and adjustment instructions. Your satisfaction is very important to us, **PLEASE DO NOT RETURN UNTIL YOU HAVE CONTACTED US:** support@sunnyhealthfitness.com or 1- 877 - 90SUNNY (877-907-8669).



WWW.SUNNYHEALTHFITNESS.COM

IMPORTANT SAFETY INFORMATION







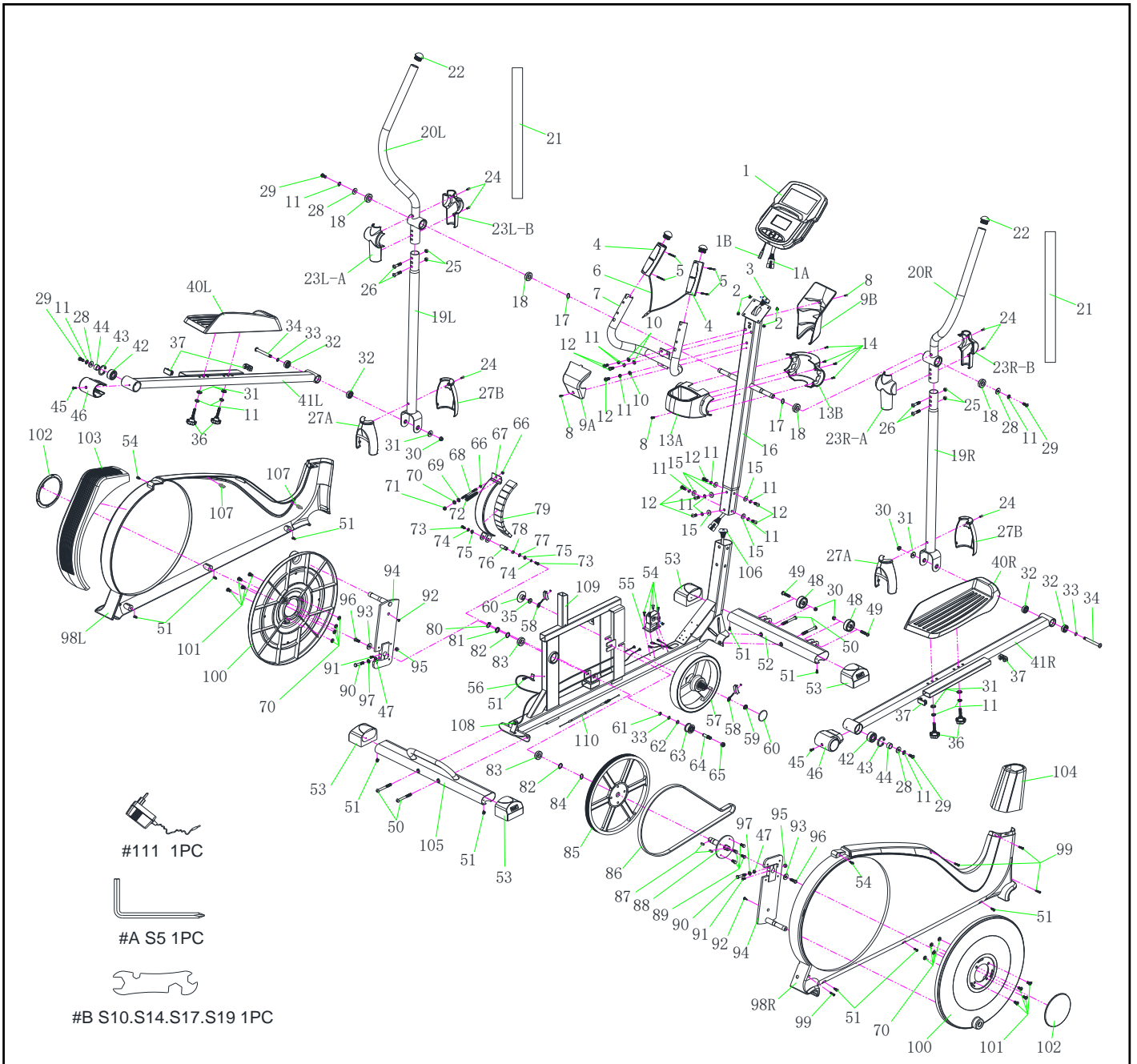





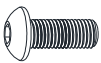

We thank you for choosing our product. To ensure your safety and health, please use this equipment correctly. It is important to read this entire manual before assembling and using the equipment. Safe and effective use can only be achieved if the equipment is assembled, maintained, and used properly. It is your responsibility to ensure that all users of the equipment are informed of all warnings and precautions.

1. Before starting any exercise program, you should consult your physician to determine if you have any medical or physical conditions that could put your health and safety at risk or prevent you from using the equipment properly. Your physician's advice is essential if you are taking medication that affects your heart rate, blood pressure or cholesterol level.
2. Be aware of your body's signals. Incorrect or excessive exercise can damage your health. Stop exercising if you experience any of the following symptoms: pain, tightness in your chest, irregular heartbeat, shortness of breath, lightheadedness, dizziness, or feelings of nausea. If you do experience any of these conditions, you should consult your physician before continuing with your exercise program.
3. Keep children and pets away from the equipment. The equipment is designed for adult use only.
4. Use the equipment on a solid, flat level surface with a protective cover for your floor or carpet. To ensure safety, the equipment should have at least 2 feet (60CM) of free space all around it.
5. Ensure that all nuts and bolts are securely tightened before using the equipment. The safety of the equipment can only be maintained if it is regularly examined for damage and/or wear and tear.
6. Always use the equipment as indicated. If you find any defective components while assembling or checking the equipment, or if you hear any unusual noises coming from the equipment during exercise, discontinue use of the equipment immediately and do not use until the problem has been rectified.
7. Wear suitable clothing while using the equipment. Avoid wearing loose clothing that may become entangled in the equipment.
8. Do not place fingers or objects into the moving parts of the equipment.
9. The maximum weight capacity of this unit is 330 pounds (150 KG).
10. The equipment is not suitable for therapeutic use.
11. To avoid bodily injury and/or damage to the product or property, proper lifting and moving are required.
12. Your product is intended for use in cool and dry conditions. You should avoid storage in extreme cold, hot, or damp areas as this may lead to corrosion and other related problems.
13. This equipment is designed for indoor and home use only; it is not intended for commercial use.

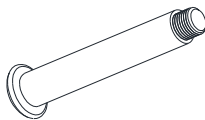
EXPLODED DIAGRAM

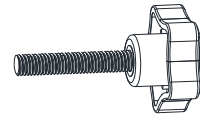
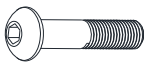

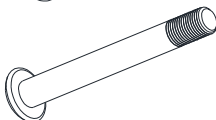
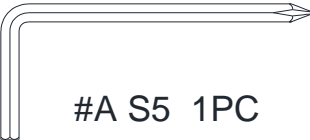
HARDWARE PACKAGE

	#10 $\Phi 8 \times 16 \times 1.5T$ 3PCS		#29 M8*20 4PCS
	#11 $\Phi 8$ 17PCS		#30 M8 2PCS
	#12 M8*20 9PCS		#31 $\Phi 8 \times 19 \times 2T$ 6PCS
	#15 $\Phi 8 \times 19 \times 1.5T$ 6PCS		#33 $\Phi 10 \times 15 \times 0.5T$ 2PCS
	#17 $\Phi 17 \times 25 \times 0.5T$ 2PCS		#34 M8*86 2PCS
	#25 M8 4PCS		#36 M8*43 4PCS
	#26 M8*43 4PCS		#44 $\Phi 17.5 \times 22 \times 12T$ 2PCS
	#28 $\Phi 8 \times 24 \times 2T$ 4PCS		#50 M8*92 4PCS
	#A S5 1PC		#B S10.S14.S17.S19 1PC

Ordering Replacement Parts (U.S. and Canadian Customers only)

Please provide the following information in order for us to accurately identify the part(s) needed:

- ✓ The model number (found on cover of manual)
- ✓ The product name (found on cover of manual)
- ✓ The part number found on the "EXPLODED DIAGRAM" and "PARTS LIST" (found near the front of the manual)

Please contact us at support@sunnyhealthfitness.com or 1- 877 - 90SUNNY (877-907-8669)

PARTS LIST

No.	Description	Spec.	Qty.
1	Computer	TZ-4113P	1
1A	Computer Cable A	Attach 6	1
1B	Computer Cable B	Attach 3	1
2	Screw	M5*12	4
3	Upper Computer Cable	1050MM	1
4	Hand Pulse Sensor		2
5	Screw	M2.5*33	4
6	Hand Pulse Cable	650MM	1
7	Handlebar	Φ32*1.5T	1
8	Screw	M5*15	3
9A	Rear Handlebar Post Cover		1
9B	Front Handlebar Post Cover		1
10	Washer	Φ8*16*1.5T	3
11	Spring Washer	Φ8	17
12	Bolt	M8*20	9
13A	Central Shaft Plastic Cover-Rear		1
13B	Central Shaft Plastic Cover-Front		1
14	Self-tapping Screw	M4*20	4
15	Washer	Φ8*19*1.5T	6
16	Handlebar Post	55*61*1.5*950MM	1
17	Wave Washer	Φ17*25*0.5T	2
18	Bearing	6203-2RS	4
19L	Left Lower Swing Bar	Φ38*1.5T	1
19R	Right Lower Swing Bar	Φ38*1.5T	1
20L	Left Upper Swing Bar	Φ32*1.8T	1
20R	Right Upper Swing Bar	Φ32*1.8T	1
21	Foam	Φ32*3T	2
22	End Cap	Φ32*36	2
23L-A	Left Upper Central Shaft Plastic Cover -A		1
23L-B	Left Upper Central Shaft Plastic Cover -B		1

No.	Description	Spec.	Qty.
23R-A	Right Upper Central Shaft Plastic Cover -A		1
23R-B	Right Upper Central Shaft Plastic Cover -B		1
24	Screw	M4*20	6
25	Lock Nut	M8	4
26	Bolt	M8*43	4
27A	Lower Swing Plastic Cover-Rear		2
27B	Lower Swing Plastic Cover-Front		2
28	Washer	Φ8*24*2T	4
29	Bolt	M8*20	4
30	Nylon Nut	M8	4
31	Washer	Φ8*19*2T	6
32	Bearing	6200-2RS	4
33	Wave Washer	Φ10*15*0.5T	3
34	Bolt	M8*86	2
35	Nut	M10*1.25	1
36	Knob	M8*43	4
37	Square Pipe Plug	20*40	4
40L	Left Pedal		1
40R	Right Pedal		1
41L	Left Pedal Support Bar	30*60*1.8T	1
41R	Right Pedal Support Bar	30*60*1.8T	1
42	Bearing	2203-2RS	2
43	C Clip	Φ40	2
44	Crank Tube	Φ17.5*22*12T	2
45	Screw	M5*7.5	2
46	M Plastic Cover	Φ46	2
47	Spring Washer	Φ8	2
48	Transportation Wheel	Φ48*21	2
49	Bolt	M8*38	2
50	Bolt	M8*92	4

No.	Description	Spec.	Qty.
51	Screw	M5*15	11
52	Front Stabilizer	40*80*1.8T	1
53	Stabilizer End Cap	40*80	4
54	Screw	M5*20	6
55	Motor		1
56	Sensor	1000MM	1
57	Flywheel	Φ250*34 8KG	1
58	Chain Adjust Set		2
59	Nut	M10*1.25	1
60	Axis Cover		2
61	C Clip	Φ8	1
62	Washer	Φ10*15*1T	1
63	Idler Wheel	Φ37*20.5L	1
64	Idler Wheel Axis	Φ10*42MM	1
65	Nylon Nut	M10	1
66	Nut	M6/10MM	2
67	Magnetic Welding	4T	1
68	Screw Stem	Φ6*80	1
69	Washer	Φ6*19*1.5T	1
70	Silica Gel Washer	Φ8*16*2T	9
71	Lock Nut	M6/10MM	1
72	Spring	Φ1*12	1
73	Bolt	M6*15	2
74	Spring Washer	Φ6	2
75	Washer	Φ6*14*1.5	2
76	Spin Axis	Φ12*33.2	1
77	Wave Washer	Φ12*17*0.5	1
78	C Clip	Φ11	1
79	Magnet	29.5*20*12MM	11
80	C Clip	Φ20	1
81	Washer	Φ20*25*2	1
82	Washer	Φ20*25*1	2

No.	Description	Spec.	Qty.
83	Bearing	6004-2RS	2
84	Wave Washer	Φ20*25*0.5	1
85	Belt Wheel	Φ350*20.2	1
86	Belt	550 J6	1
87	Cotter Pin		2
88	Round Metal Welding	Φ20*111MM	1
89	Screw Stem	M8*12	4
90	Screw Stem	M8*50	2
91	Bolt	M6*15	2
92	Self-tapping Screw	M4.5*15	2
93	Washer	8*24*2T	2
94	Cross Welding	8T	2
95	Nut	M8/14MM	2
96	Screw Stem	M8*20	2
97	Washer	Φ8*16*2	2
98L	Left Belt Cover	ABS	1
98R	Right Belt Cover	ABS	1
99	Self-tapping Screw	M4.5*25	4
100	Cycle Plate	ABS	2
101	Bolt	M6*15	8
102	Crank Cover		2
103	Back Plastic Cover		1
104	Front Plastic Cover		1
105	Rear Stabilizer	40*80*1.8T	1
106	Lower Computer Cable	850MM	1
107	Plastic Screw		2
108	DC Cable	1000MM	1
109	Main Frame		1
110	Conduction Wire	850MM	1
111	Adapter	9V/1.0A	1
A	Allen Wrench	S5	1
B	Spanner	S10, S14, S17, S19	1

ASSEMBLY INSTRUCTIONS

We value your experience using Sunny Health and Fitness products. For assistance with parts or troubleshooting, please contact us at support@sunnyhealthfitness.com or 1-877-90SUNNY (877-907-8669).

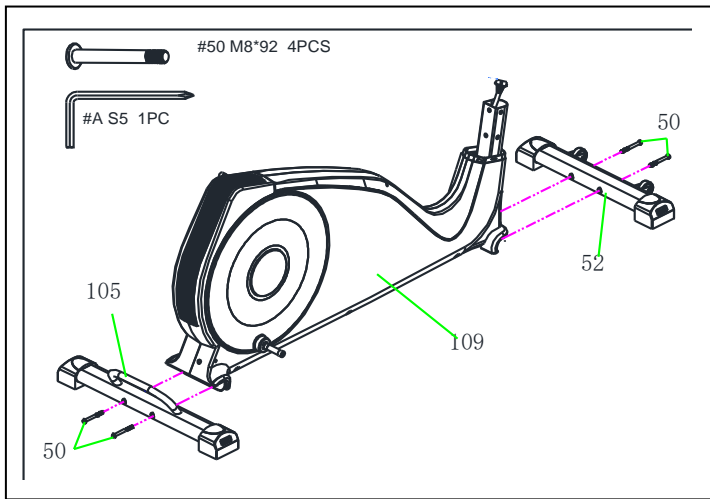

STEP 1:

Attach the **Front Stabilizer (No. 52)** to the **Main Frame (No. 109)** with 2 **Bolts (No. 50)**. Tighten and secure with **Allen Wrench (No. A)**.

Attach the **Rear Stabilizer (No. 105)** to the **Main Frame (No. 109)** with 2 **Bolts (No. 50)**. Tighten and secure with **Allen Wrench (No. A)**.

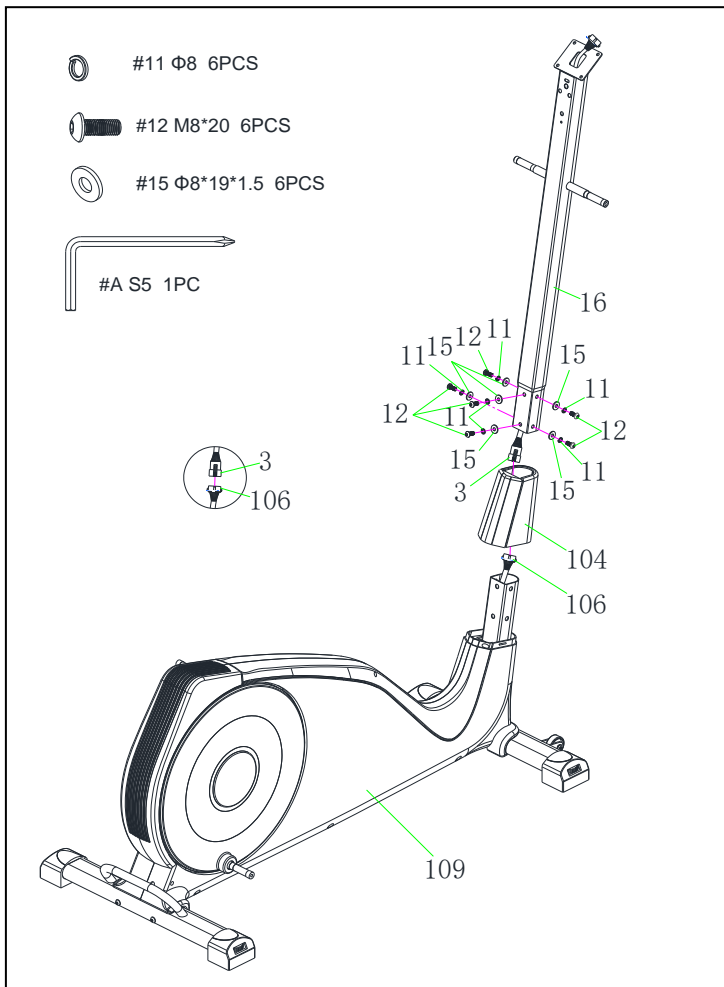

STEP 2:

Put the **Front Plastic Cover (No. 104)** through the **Handlebar Post (No. 16)**.

Connect the **Lower Computer Cable (No. 106)** with the **Upper Computer Cable (No. 3)**.

Attach the **Handlebar Post (No. 16)** to the **Main Frame (No. 109)** with 6 **Spring Washers (No. 11)**, 6 **Washers (No. 15)**, and 6 **Bolts (No. 12)**. Tighten and secure with **Allen Wrench (No. A)**. Then, place the **Front Plastic Cover (No. 104)** into position.

We value your experience using Sunny Health and Fitness products. For assistance with parts or troubleshooting, please contact us at support@sunnyhealthfitness.com or 1-877-90SUNNY (877-907-8669).

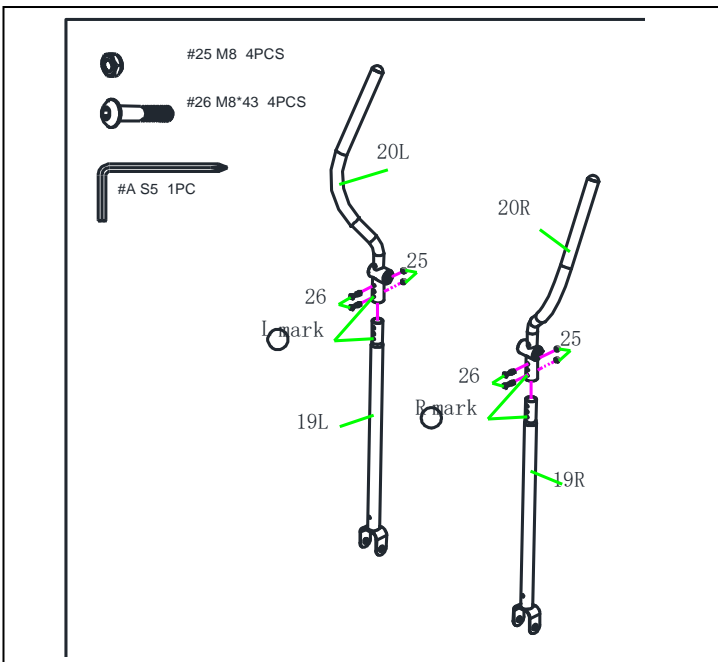

STEP 3:

Attach the **Left Upper Swing Bar (No. 20L)** to **Left Lower Swing Bar (No. 19L)** with 2 **Bolts (No. 26)** and 2 **Nuts (No. 25)**. Tighten and secure with **Allen Wrench (No. A)**.

Note: The L/R mark on **Left & Right Upper Swing Bars (No. 20L & No. 20R)** and **Left & Right Lower Swing Bars (No. 19L & No. 19R)** should always be assembled facing front direction.

Please repeat this assembly step to the Right side.

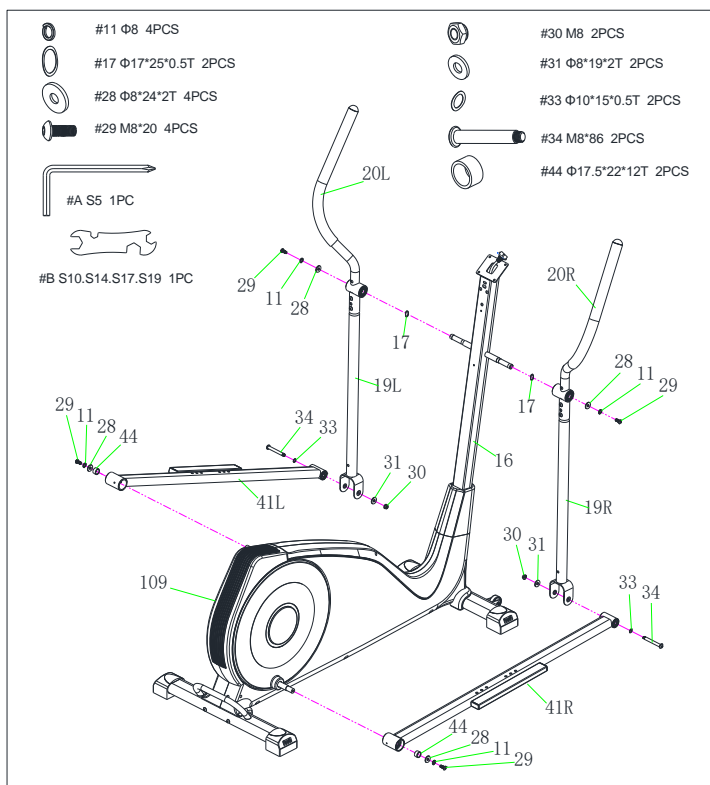

STEP 4:

Attach the **Left & Right Lower Swing Bars (No. 19L/R)** to the **Handlebar Post (No. 16)** with 2 **Wave Washers (No. 17)**, 2 **Washers (No. 28)**, 2 **Spring Washers (No. 11)**, and 2 **Bolts (No. 29)**. Tighten and secure with **Allen Wrench (No. A)**.

Attach the **Left & Right Lower Swing Bars (No. 19L/R)** to the **Left & Right Pedal Support Bars (No. 41L/R)** with 2 **Nylon Nuts (No. 30)**, 2 **Washers (No. 31)**, 2 **Wave Washers (No. 33)**, and 2 **Bolts (No. 34)**. Tighten and secure with **Allen Wrench (No. A)** and **Spanner (No. B)**.

Note: For the **Left & Right Pedal Support Bars (No. 41L/R)**, the side with more holes needs to face up to attach **Left & Right Lower Swing Bars (No. 19L/R)**.

Attach the **Left & Right Pedal Support Bars (No. 41L/R)** to the **Main Frame (No. 109)** with 2 **Washers (No. 28)**, 2 **Spring Washers (No. 11)**, 2 **Bolts (No. 29)** and 2 **Crank Tubes (No. 44)**. Tighten and secure with **Allen Wrench (No. A)**.

We value your experience using Sunny Health and Fitness products. For assistance with parts or troubleshooting, please contact us at support@sunnyhealthfitness.com or 1-877-90SUNNY (877-907-8669).

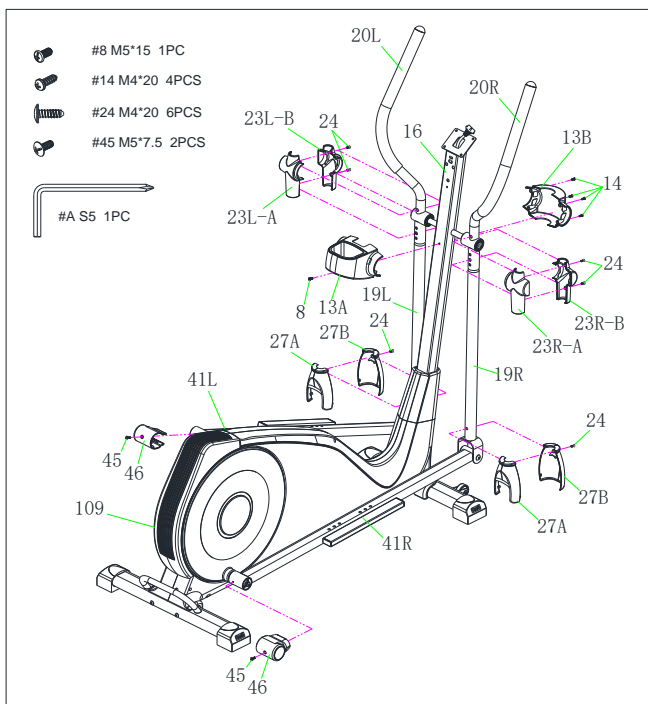

STEP 5:

Remove 2 Screws (No. 45) from the Left & Right Pedal Support Bars (No. 41L/R).

Attach the M Plastic Covers (No. 46) to the Left & Right Pedal Support Bars (No. 41L/R) with 2 Screws (No. 45) that were removed. Tighten and secure with Allen Wrench (No. A).

Remove 2 Screws (No. 24) from the Lower Swing Plastic Covers (No. 27A/B).

Attach the Lower Swing Plastic Covers (No. 27A/B) to the Left & Right Lower Swing Bars (No. 19L/R) with 2 Screws (No. 24) that were removed. Tighten and secure with Allen Wrench (No. A).

Remove 4 Screws (No. 24) from the Left & Right Upper Central Shaft Plastic Covers (No. 23L-A/B & No. 23R-A/B).

Attach the Left & Right Upper Central Shaft Plastic Covers (No. 23L-A/B & No. 23R-A/B) to the Left & Right Upper Swing Bars (No. 20L/R) with 4 Screws (No. 24) that were removed. Tighten and secure with Allen Wrench (No. A).

Remove 4 Self-tapping Screws (No. 14) from the Central Shaft Plastic Covers (No. 13A/B). Remove 1 Screw (No. 8) from the Handlebar Post (No. 16).

Attach the Central Shaft Plastic Covers (No. 13A/B) to the Handlebar Post (No. 16) using 4 Self-tapping Screws (No. 14) and 1 Screw (No. 8) that were removed. Tighten and secure with Allen Wrench (No. A).

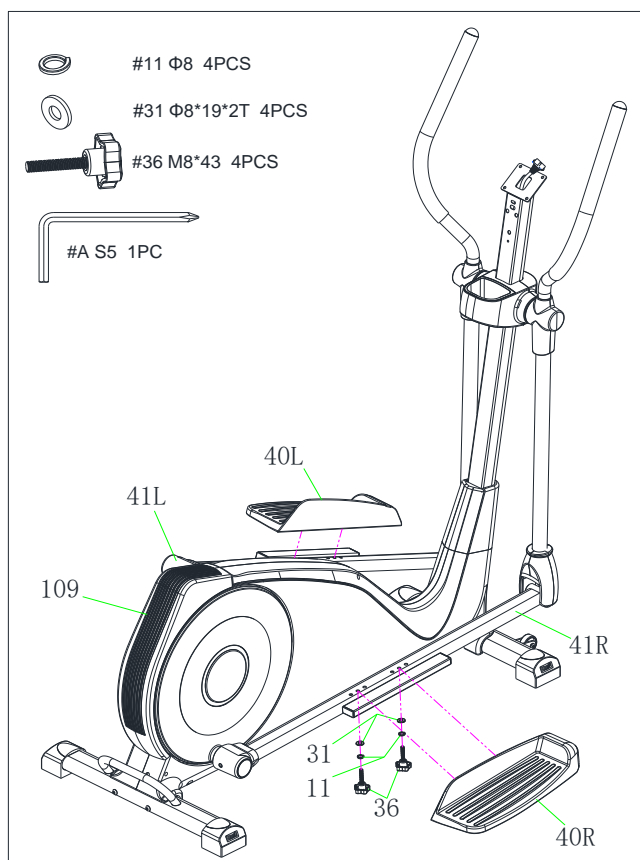

STEP 6:

Attach the Right Pedal (No. 40R) to Right Pedal Support Bar (No. 41R) using 2 Washers (No. 31), 2 Spring Washers (No. 11), and 2 Knobs (No. 36). Tighten and secure with Allen Wrench (No. A).

Please repeat this assembly step to the Left side.

We value your experience using Sunny Health and Fitness products. For assistance with parts or troubleshooting, please contact us at support@sunnyhealthfitness.com or 1-877-90SUNNY (877-907-8669)

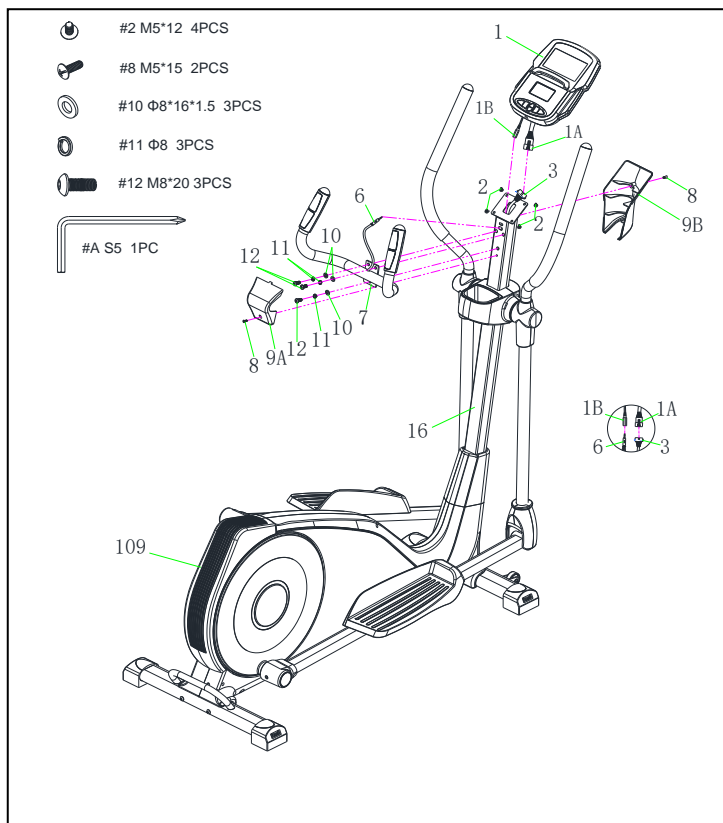

STEP 7:

Attach **Handlebar (No. 7)** to the **Handlebar Post (No. 16)** with 3 **Spring Washers (No. 11)**, 3 **Washers (No. 10)**, and 3 **Bolts (No. 12)**. Tighten and secure with **Allen Wrench (No. A)**.

Insert the **Hand Pulse Cable (No. 6)** into the front hole of **Handlebar Post (No. 16)** and pull up the **Hand Pulse Cable (No. 6)** from the top hole the **Handlebar Post (No. 16)**.

Remove 4 **Screws (No. 2)** from the back of the **Computer (No. 1)**.

Connect the **Upper Computer Cable (No. 3)** to the **Computer Cable A (No. 1A)**. Connect the **Hand Pulse Cable (No. 6)** to the **Computer Cable B (No. 1B)**.

Attach the **Computer (No. 1)** onto the top end of **Handlebar Post (No. 16)** using 4 **Screws (No. 2)** that were removed. Tighten and secure with **Allen Wrench (No. A)**.

Remove 2 **Screws (No. 8)** from the **Handlebar Post (No. 16)**.

Attach the **Front & Rear Handlebar Post Covers (No. 9A/B)** to the **Handlebar Post (No. 16)** using 2 **Screws (No. 8)** that were removed. Tighten and secure with **Allen Wrench (No. A)**.

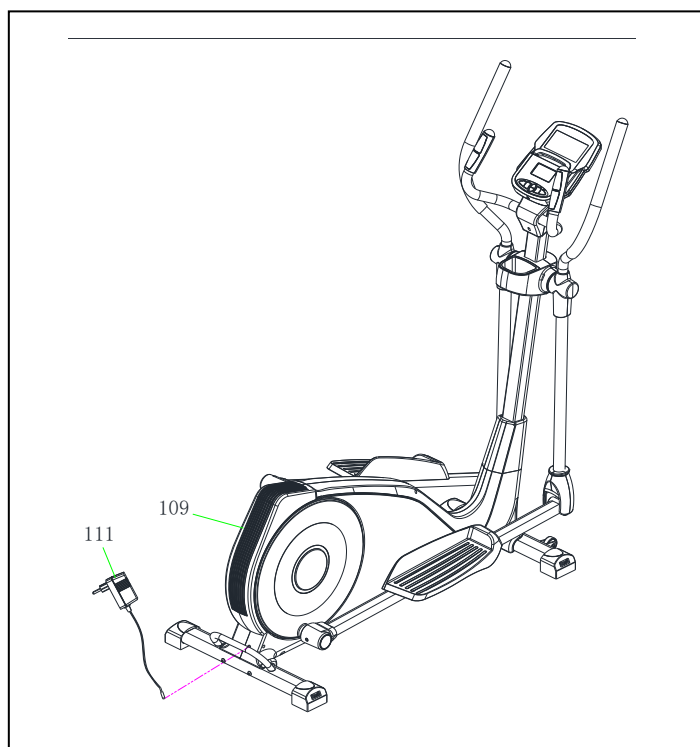

STEP 8:

Before plugging in the elliptical, make sure to check the **Adapter (No. 111)** specifications carefully.

Plug one end of the **Adapter (No. 111)** into the power plug at the end of **Main Frame (No. 109)**.

The assembly is complete!

ADJUSTMENTS & USAGE GUIDE

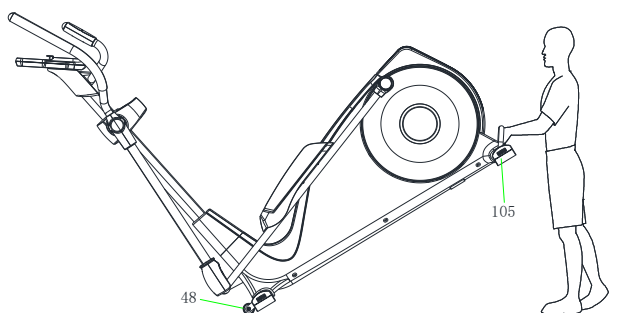

HOW TO MOVE THE ELLIPTICAL

The **Transportation Wheels (No. 48)** in front of the **Front Stabilizer (No. 52)** are movable. Hold the **Rear Stabilizer (No. 105)** and pull forward to lift the rear end of the elliptical off the floor. Once the **Transportation Wheels (No. 48)** touch the ground, you could move the elliptical now.

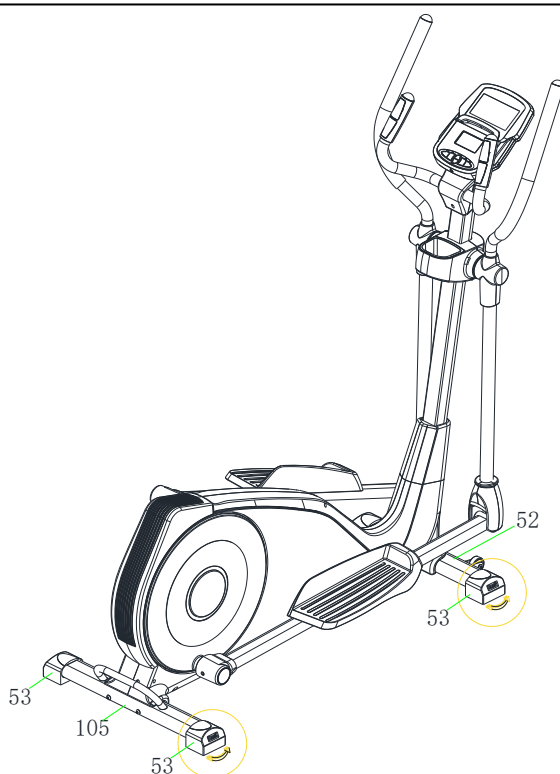

ADJUSTING THE BALANCE

In order to achieve a smooth and comfortable ride, you must ensure that the elliptical is stable. If you notice that the elliptical is unbalanced during use, you should adjust the **Stabilizer End Caps (No. 53)** located beneath the **Front Stabilizer (No. 52)** and **Rear Stabilizer (No. 105)**.

CLEANING AND MAINTENANCE:

The elliptical can be cleaned with a soft cloth and mild detergent. Do not use abrasives or solvents on plastic parts. Please wipe your perspiration off the elliptical after each use. Be careful not get excessive moisture on the computer display panel, as this may cause electrical hazards or cause electronics to fail. Please keep the elliptical and the console out of direct sunlight to prevent screen damage. Please inspect all assembly bolts and pedals on the elliptical for proper tightness every week.

STORAGE:

Store the elliptical in a clean and dry environment away from children.

IMPORTANT ELECTRICAL INFORMATION

WARNING: This elliptical trainer requires a power source of **1 amp (100-240V)** in order to properly operate. For your safety, as well as the safety of others, please verify that the power source is correct before plugging in the equipment. Any power source above or below this level could cause significant damage to the equipment and/or user.

OPERATING INSTRUCTIONS

Plug the adapter into the elliptical trainer and into the outlet.
The computer will turn on.
The computer will turn off if there is no activity for 4 minutes. Press any button on the computer to turn it on again.

NOTE: You can still use the elliptical trainer when it is not plugged in. However, the computer will not be working and you cannot adjust the resistance level or use any of the functions.

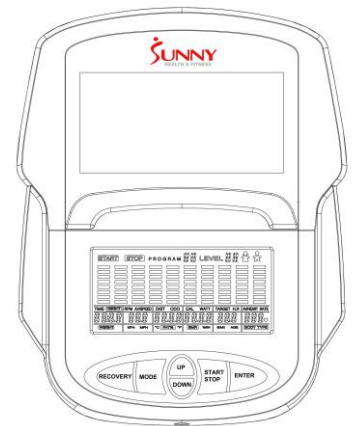

EXERCISE COMPUTER

KEY FUNCTIONS:

KEY	FUNCTION
START/STOP	Start and pause workouts. Start body fat measurement.
DOWN	Lower the resistance level during workout. Decrease value of selected parameter.
UP	Increase the resistance level during workout. Increase value of selected parameter.
ENTER	To input the value or mode.
RECOVERY	Enter Recovery function when computer displays the heart rate value. Recovery displays F1-F6. F1 is poor recovery heart rate. F6 is excellent recovery heart rate.
MODE	During workout, switch display from RPM to SPEED, ODO to DIST and WATT to CALORIES. Hold for 3 seconds to reset all function values to zero, except ODO.

WORKOUT SELECTION:

After turning the computer on by plugging in the adapter or if already plugged in, pressing any button on the computer, use the UP or DOWN button to make a selection. Then press ENTER button to choose the desired mode.

There are 7 basic workout modes:

Manual, Pre-set Program, Watt Program, Body Fat Program, Target Heart Rate Program, Heart Rate Control Program, and User Program.

FUNCTIONS:

SPEED: Displays current training speed. Maximum speed is 99.9 MPH.

RPM: Displays current rotation per minute.

TIME: Accumulates the workout time from 00:00 to 99:59. Users can preset the target time they want.

DIST (DISTANCE): Accumulates the workout distance from 0.00 to 999.9 miles. Users can preset the target distance they want to reach.

ODO (ODOMETER): Displays the total accumulated distance from 0 to 9999 miles.

CAL (CALORIES): Accumulates the calories burned from 0 to 9999 calories. Users can preset the target Calories they want to burn.

WATT: Displays current watt.

HEART RATE: Displays the current heart rate in beats per minute.

TARGET HR (TARGET HEART RATE): Users can preset their Target Heart Rate.

PROGRAM: There are 24 different programs to choose for training.

LEVEL: The program has 10 columns of bars and 8 bars in each column. Each column represents a 1-minute workout and each bar represents 2 resistance levels.

WORKOUT PARAMETERS:

TIME / DISTANCE / CALORIES / AGE / WATT / TARGET HEART RATE

Setting Workout Parameters

After selecting the desired workout mode: Manual Program, Pre-set Program, Watt Control Program, Body Fat Program, Target Heart Rate Program, Heart Rate Control Program, and User Program. You may pre-set several workout parameters for desired results.

Note: Some parameters are not adjustable in certain programs. Time and Distance cannot be set up at the same time.

Once a program has been selected, press ENTER and TIME will flash.

Using the UP or DOWN button, you may select the desired time value. Press ENTER to input the values. The flashing prompt will move to the next parameter. Continue using the UP or DOWN button. Press the START/STOP button to begin the workout.

More About Workout Parameters

Field	Setting Range	Default Value	Increment/Decrement	Description
Time	0:00~99:00	00:00	±1:00	1. When display is set as 0:00, Time will count up. 2. When time is set as 1:00-99:00, it will count down to 0.
Distance	0.00~999.0	0.00	±1.0	1. When display is set as 0.0, Distance will count up. 2. When Distance is set as 1.0~999.0 miles, it will count down to 0.
Calories	0~9995	0	±5	1. When display is set as 0, Calories will count up. 2. When Calories is set as 5~9995 calories, it will count down to 0.
Watt	50~250	100	±5	User can set watt value only in the Watt Control Program.
Age	10~99	30	±1	Target HR will be based on Age. When Heart Rate exceeds Target HR, the Heart Rate number will flash.
Pulse	60~220	90	±1	Setting Parameters for Target heart rate.

PROGRAM OPERATION:

Manual Program (P1)

Program profile

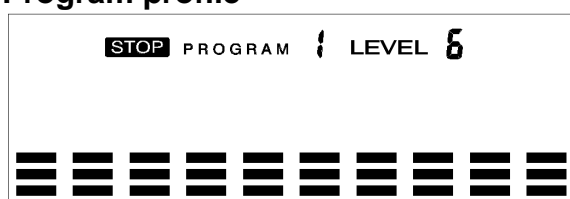

SETTING PARAMETERS FOR MANUAL PROGRAM

1. Select **Manual Program (P1)** using the UP or DOWN button, then press ENTER.
2. TIME will flash so the value can be adjusted using the UP or DOWN button.
3. Press the ENTER button to save the value and move to the next parameter to be adjusted.
Note: If you set up the target time for workout, then the next parameter of Distance cannot be adjusted.
4. Continue through all desired parameters and press the START/STOP button to begin the workout.
Note: Once the workout parameter counts down to zero, it will beep and stop the workout automatically. Press the START button to continue the workout to reach the unfinished workout parameter.

Pre-set programs (P2~P13)

Program profile

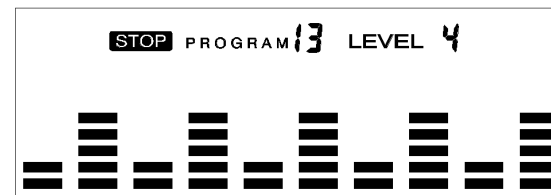
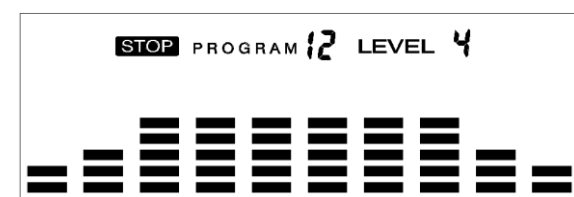
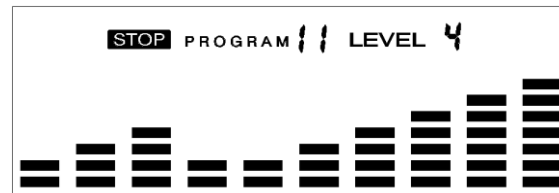
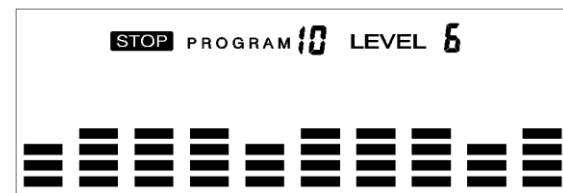
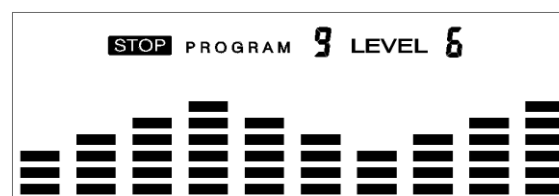
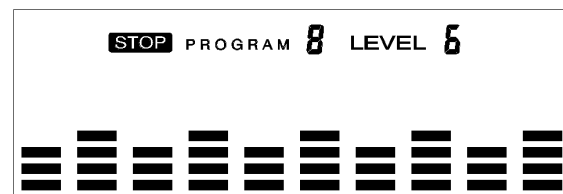
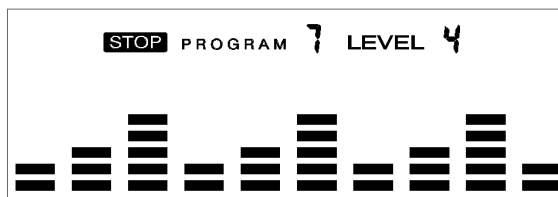
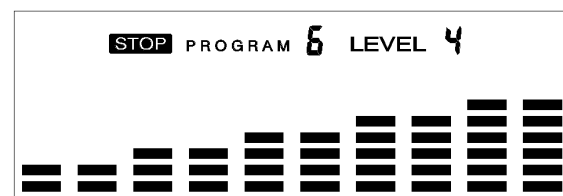
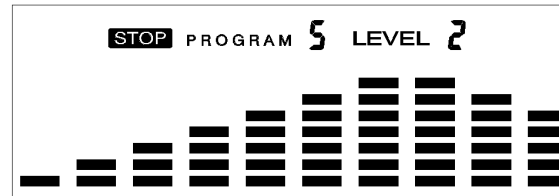
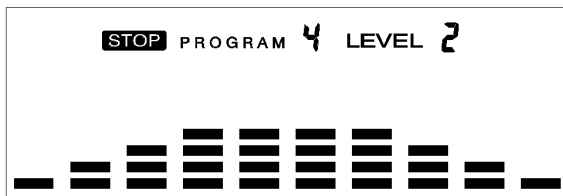
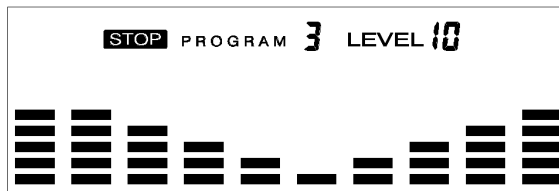
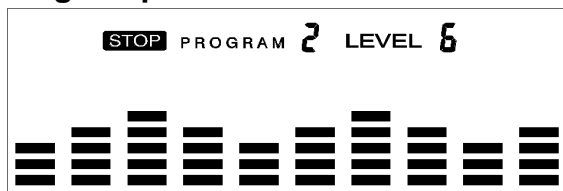

There are 12 pre-set programs ready for use. All program profiles have 16 levels of resistance.

SETTING PARAMETERS FOR PRE- SET PROGRAMS

1. Select one of the **Pre-set Programs** using the UP or DOWN button, then press ENTER. TIME will flash so the value can be adjusted using the UP or DOWN key.
2. Press the ENTER button to save value and move to the next parameter to be adjusted. Continue through all desired parameters, pressing the START/STOP button to begin the workout.

Workout in any pre-set program

You can adjust the level of resistance by pressing the UP or DOWN button during the workout.

Note: If you set up the target time for workout, then the next parameter of Distance cannot be adjusted. Once the workout parameter counts down to zero, it will beep and stop the workout automatically. Press the START button to continue the unfinished parameter.

Watt Control Program (P14)

Program profile

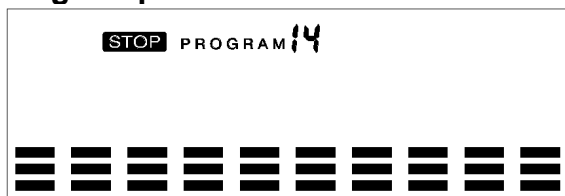

SETTING PARAMETERS FOR THE WATT CONTROL PROGRAM

1. Select **Watt Control Program (P14)** using the UP or DOWN button, then press ENTER.
2. TIME will flash so the value can be adjusted using the UP or DOWN button.
3. Press ENTER button to save the value and move to the next parameter to be adjusted.
Note: If you set up the target time for workout, then the next parameter of Distance cannot be adjusted.
4. Continue through all desired parameters, pressing the START/STOP button to start the workout.
Note: Once the workout parameters count down to zero, it will beep and stop the workout automatically.
5. Press the START button to continue the workout to reach the unfinished workout parameter.
The computer will adjust the resistance load automatically depending on the speed to maintain the constant watt value. You can use the UP or DOWN button to adjust the watt value during the workout.

BODY FAT Program (P15)

Program profile

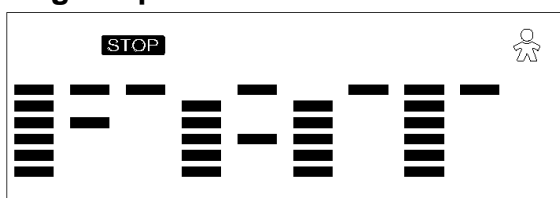

SETTING DATA FOR BODY FAT

Select **BODY FAT Program (P15)** using the UP or DOWN button, then press ENTER. "MALE" will flash so Gender can be adjusted using the UP or DOWN button. Press the ENTER button to save gender and move to the next data.

"5'8 (inches)" of Height will flash so Height can be adjusted using the UP or DOWN button. Press ENTER to save the value and move to the next data.

"154 (lbs)" of Weight will flash so Weight can be adjusted using the UP or DOWN button. Press ENTER to save the value and move to the next data.

"30" of Age will flash so Age can be adjusted using the UP or DOWN button. Press ENTER to save the value.

Press the START/STOP button to start the measurement. Please also remember to grasp the hand pulse sensors. After 15 seconds the display will show Body Fat %, BMR, BMI, & BODY TYPE.

Body Types:

There are 9 body types divided according to the FAT % calculated.

Body Type	FAT %	Body Type	FAT %	Body Type	FAT %
Type 1	5% - 9%	Type 4	20% - 24%	Type 7	35% - 39%
Type 2	10% - 14%	Type 5	25% - 29%	Type 8	40% - 44%
Type 3	15% - 19%	Type 6	30% - 34%	Type 9	45% - 50%

BMR: Basal Metabolism Ratio

BMI: Body Mass Index

Press START/STOP button to return the main display.

TARGET HEART RATE Program (P16)

Program profile

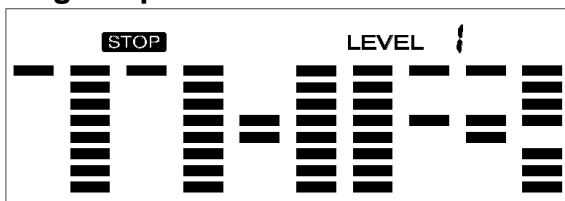

SETTING PARAMETERS FOR TARGET HEART RATE PROGRAM

1. Select **TARGET HEART RATE program (P16)** using the UP or DOWN button, then press ENTER.
2. TIME will flash. The value can be adjusted using the UP or DOWN button.
3. Press the ENTER button to save the value and move to the next parameter to be adjusted.
Note: If you set up the target time to workout, then the next parameter of Distance cannot be adjusted.
4. Continue through all desired parameters, pressing START/STOP button to start workout.
Note: If Pulse is above the set TARGET HR, the Pulse value will flash to remind the user.

HEART RATE CONTROL Program (P17-P20)

Program profile

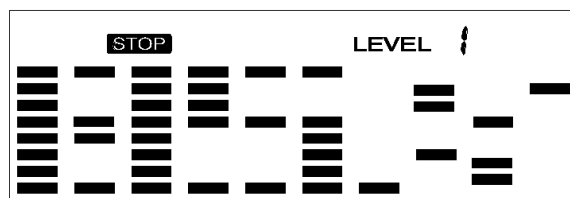
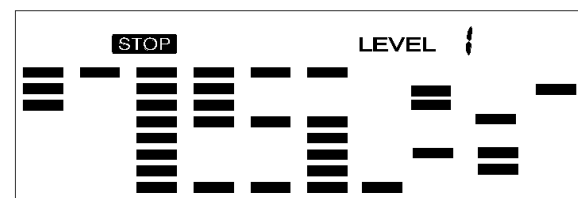
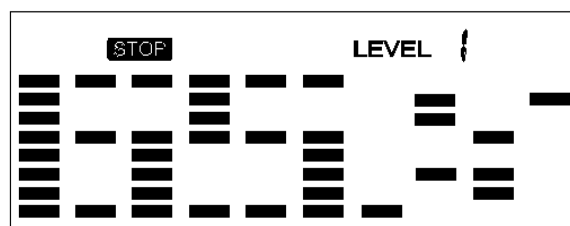
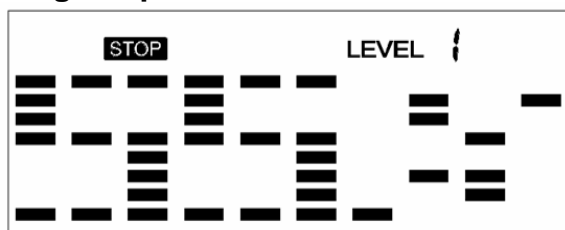

There are 4 selections for target pulse (HR):

HRC - 55% TARGET HR= 55% of (220-AGE)

HRC - 65% TARGET HR= 65% of (220-AGE)

HRC - 75% TARGET HR= 75% of (220-AGE)

HRC - 85% TARGET HR= 85% of (220-AGE)

SETTING PARAMETERS FOR HEART RATE CONTROL

1. Select one of the **Heart Rate Control Programs** using the UP or DOWN button, then press ENTER.
2. TIME will flash. The value can be adjusted using the UP or DOWN button.
3. Press the ENTER button to save the value and move to the next parameter to be adjusted.

Note: If you set up the target time to work out, then the next parameter of Distance cannot be adjusted.

4. Continue through all desired parameters, pressing the START/STOP button to start the workout.

Note: If Pulse is above or below (± 5) the TARGET HR, the computer will adjust the resistance load automatically. It will check every 20 seconds approx. 1 resistance load will increase or decrease (Note: each resistance load represents 2 levels of loading).

If one of the workout parameters counts down to be zero, it will beep and stop the workout automatically. Press the START/STOP button to continue the workout to reach unfinished workout parameter.

User Program

Program profile (P21-P24)



The 4 user programs allow the user to set their own program that can be used immediately.

SETTING PARAMETERS FOR USER PROGRAM

1. Select the **User Program** using the UP or DOWN button then press ENTER.
2. TIME will flash so the value can be adjusted using the UP or DOWN button.
3. Press the ENTER button to save the values and move to the next parameter to be adjusted.

Note: If you set up the target time to work out, then the next parameter of Distance cannot be adjusted.

4. Continue through all desired parameters.
5. After finishing the setup of the desired parameters, level 1 will flash. Use the UP or DOWN button to adjust, then press the ENTER button until finished. (There are 10 times total). Press the START/STOP button to begin the workout.

Note: Once the workout parameter counts down to zero, it will beep and stop the workout automatically. Press the START/STOP button to continue the workout to reach the unfinished workout parameter.

TROUBLESHOOTING

PROBLEM	POSSIBLE CAUSE	CHECK	SOLUTION
E1	The motor doesn't work.	Check if the motor wires are plugged in or check if the motor is stuck.	Plug in the motor wires again or change the motor.
	There is something wrong with the cables.	Check if the cables are damaged. This can cause a short circuit.	Change the cables or plug in again.
	The computer cannot supply normal voltage to the motor.	Test whether the voltage of the motor is normal when pressing "UP" and "DOWN".	Change the computer.
E2	The IC (Integrated Circuits) inside the computer is damaged.		Change the computer.
E4	Hands aren't put on the two handle pulses immediately after pressing START.		Put the hands on the two handle pulses immediately after pressing START.
	Body Fat Function cannot receive the signal for pulse.	Check if the handle pulse cables are well connected.	Plug in the handle pulse cables again or change the handle pulse cables.
		Check if the pulse is working when not in Body Fat program.	Change the computer.

NOTE: If you are unable to resolve an issue using the troubleshooting guide above, please contact Customer Service at support@sunnyhealthfitness.com.

CONNECT WITH US

FOR FITNESS
ARTICLES, VIDEOS
& WORKOUTS



@SUNNYHEALTHANDFITNESS



@SUNNYHEALTHFITNESS



@SUNNYHEALTHFIT



/SUNNYHEALTHFITNESS



/SUNNYHEALTHANDFITNESS

WWW.SUNNYHEALTHFITNESS.COM