

**PRO-LOK®**

655 N Hanton Street, Orange CA 92668 • tel (714)633-0681 fax: (714) 633-0470

**INJIG-MORT**

# MORTISE JIG

User's Manual

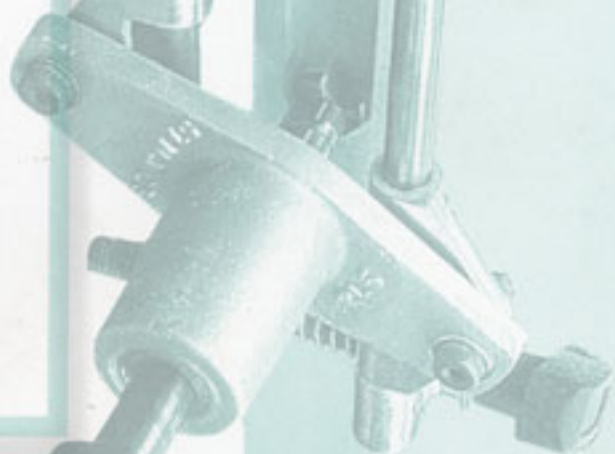

## Table of Contents

Introduction .....	page	1
Overall Assessment.....	page	2
Safety .....	page	3
Mortising Wooden Doors .....	page	5-11
Mortising Aluminum Doors .....	page	13-18
Sharpening the Cutters .....	page	19
Replacement Parts .....	page	20

## Introduction

# THE 5 MINUTE MORTISE

### CUTS A LOCK MORTISE IN UNDER 5 MINUTES

The self-centering Mortise Jig has been used by locksmiths for over 15 years and is renowned for its accuracy, efficiency and depth of cut. PRO-LOK has now refined and improved the engineering standards to ensure superior quality, reliability and it now incorporates a unique *Quick Change Cutter*, which allows the cutters to be changed in seconds without removing the jig from the door by simply depressing the end of the shaft. This means that both the full lock body and the faceplate can be cutout with ease in the shortest time. With the 5 minute Mortise Jig time on-site is reduced, accuracy is assured, with minimum disruption to the customer. No other combination of tools can produce such a fast and accurate mortise installation.

### CUTS A MORTISE INTO ALL WOODEN AND ALUMINUM DOORS

The Mortise Jig and its precision cutters will cut a mortise in hard wood, soft wood, composite doors and with the use of special cutters, aluminum doors as well, all in under five minutes.

### INCLUDED IN THE PRICE

The Mortise Jig is supplied in a heavy duty plastic carrying case, along with 3 high speed wood cutters, a long boring shaft for locks up to 6" deep and instructions.

## OVERALL ASSESSMENT

The PRO-LOK 5 minute Mortise Jig is a time and labor saving device that takes the hard work out of fitting a mortise lock. It is manufactured to a high standard and is very easy to use. The mortises cut are automatically centered and parallel to the door surface and provided the limits of cutter travel are carefully set, accurate results will follow. The jig is held on the edge of the door to suit normal lock height by two clamps that are positioned during initial setting-up on the door to limit vertical cutter travel. The cutter is locked in the end of the boring shaft which runs in a sliding aluminum housing, powered by a portable electric drill with a 1/2" chuck fitted (not included). An adjustable collar on the boring shaft sets the cutter travel into the door (mortise depth). This arrangement allows the mortise to be cut for the body of a lock, followed by a change of cutter and limit settings to cut the faceplate recess. The recess is then finished with a chisel, the mullion socket fitted in the usual manner, then apart from a few holes and furniture fittings, and your job is done.

The jig is constructed around two 1/2" diameter steel guides. These are held in place, while in use, by two clamps - one fixed at the recommended lower end of the guides, while the other clamp can be slid along the guides in order to set the limits of travel of the aluminum housing which carries the boring shaft and cutter. A spring clip on one of the guides can be used to mark the position of the adjustable (upper) clamp for repetition work. The aluminum head is mounted on two hinged slides that move independently along the steel guides as the clamps are opened or closed. This ensures that the head bearing is always midway between the steel guides. The 5/8" diameter boring shaft runs in sintered bronze "oiled for life" bearings in the aluminum housing. The cutters are inserted in a hexagonal drive socket at the end of the shaft and held firmly in place by a spring-loaded concentric ring that engages in an annular recess on the cutter shaft. In this manner, the cutter is positively driven with no endplay, ensuring that the final depth of cut is as accurate as the collar setting. The cutters can be quickly changed and sharpened locally to maintain their cutting efficiency. A range of cutters is available for wood and aluminum doors. The Mortise Jig is reasonably priced and should be an indispensable tool for all lock installers.

**SAFETY AND ADVICE**

- The mortise jig cutters are designed to run at 2000-3000 RPM on drills with a 1/2" chuck and "hammer action" OFF.
- Remove the power cord when you are adjusting the router cutter.
- Allow the router to reach full speed before starting to cut.
- Sharp routers will ensure a good finish and prevent motor overload.
- Securely tighten all clamps, set screws and drill chuck.
- When finished drilling, switch off drill, remove drill from jig and remove jig from the door.
- A trial run with a short piece of 2" x 4" wood will help to familiarize you with the operating procedures.
- Identical mortises can be made if the tube type spring clip on one of the bars is set at the upper clamp position on the first mortise.
- User must wear safety goggles at all times.
- Follow safety instructions from drill manufacturer.
- Do not force drill or cutters.



**PRO-LOK**

Set the depth of the mortise by adjusting the depth stop on the front and the depth on the bottom of the face plate (positions A & D).

# Mortising Wooden Doors

Put the depth stop on the front and the depth on the bottom of the face plate (positions A & D). Tighten both clamps securely.



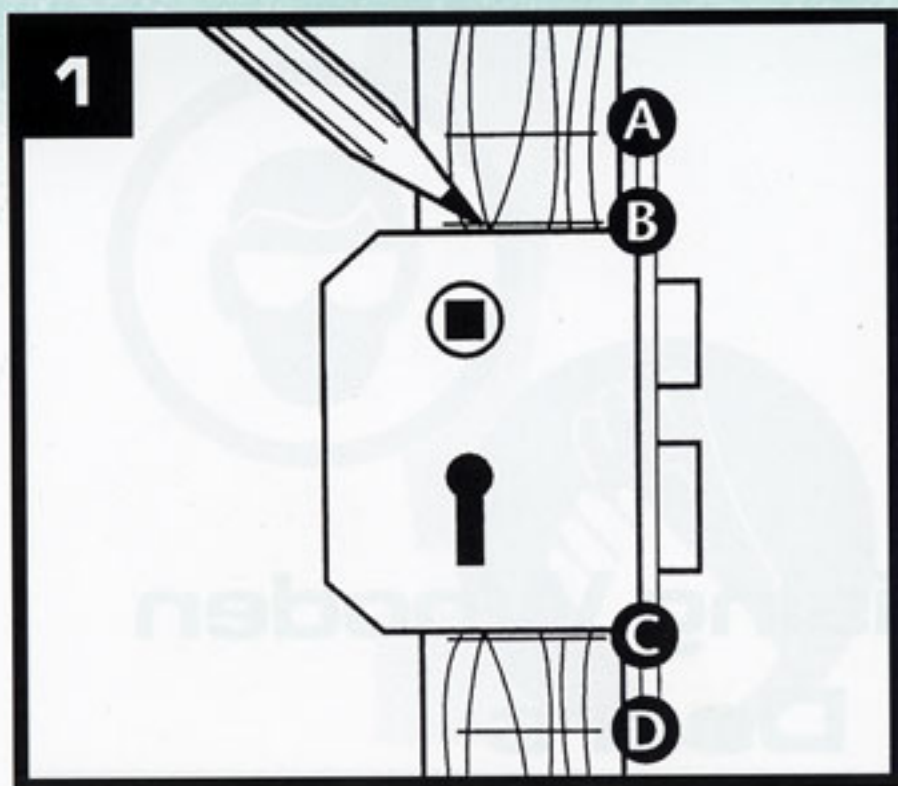

Use the lock as a template and mark off the top and bottom edges of the lock body (positions B & C) and the top and bottom of the face plate (positions A & D).

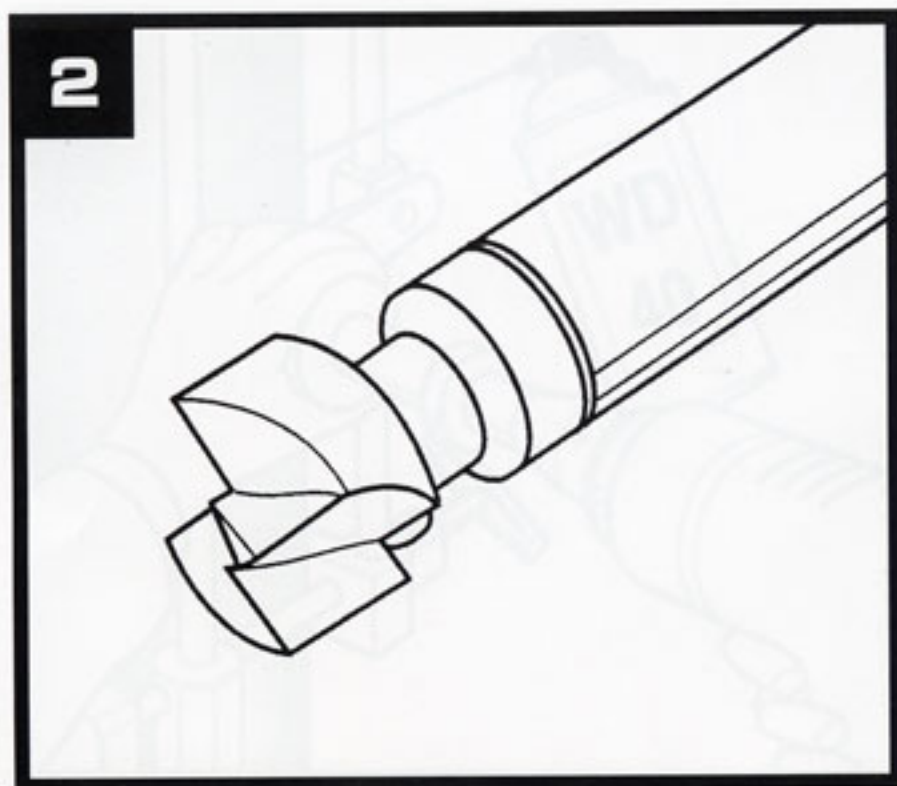

Select a cutter appropriate to thickness of the lock and secure this to the cutter shaft by pushing until it "clicks on" securely.



Insert the shaft into the aluminum housing assembly.

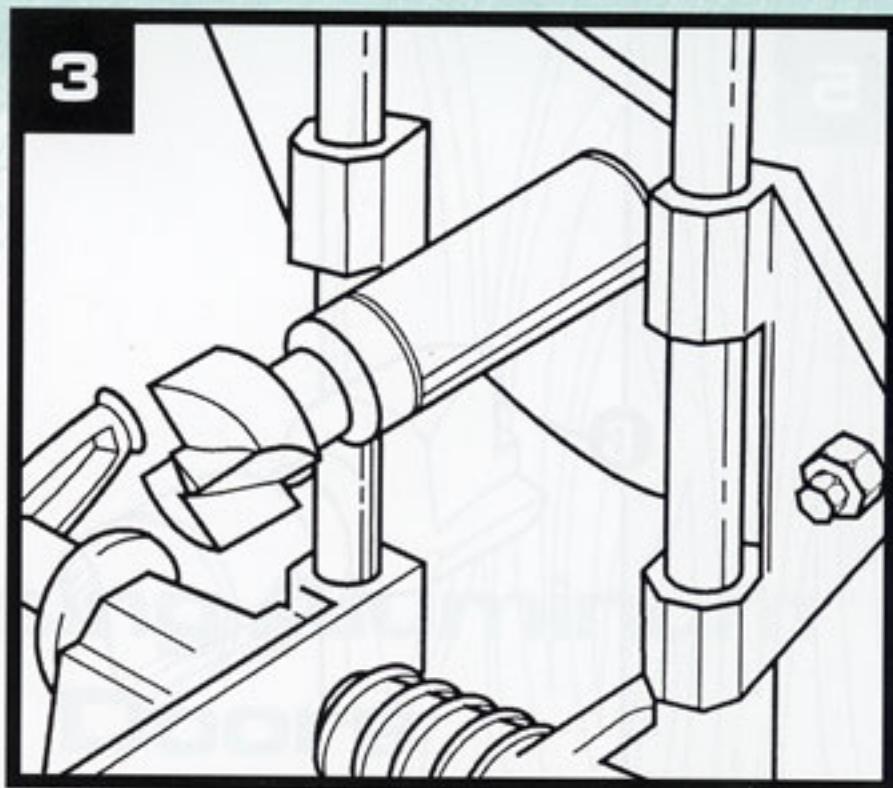

Clamp the Mortise jig to the door edge, positioning the cutter to the lowest lock body mark but overlapping by  $3/16$ " or 5mm (position C). The housing assembly should be resting on the bottom pair of clamps. Tighten bottom clamp.

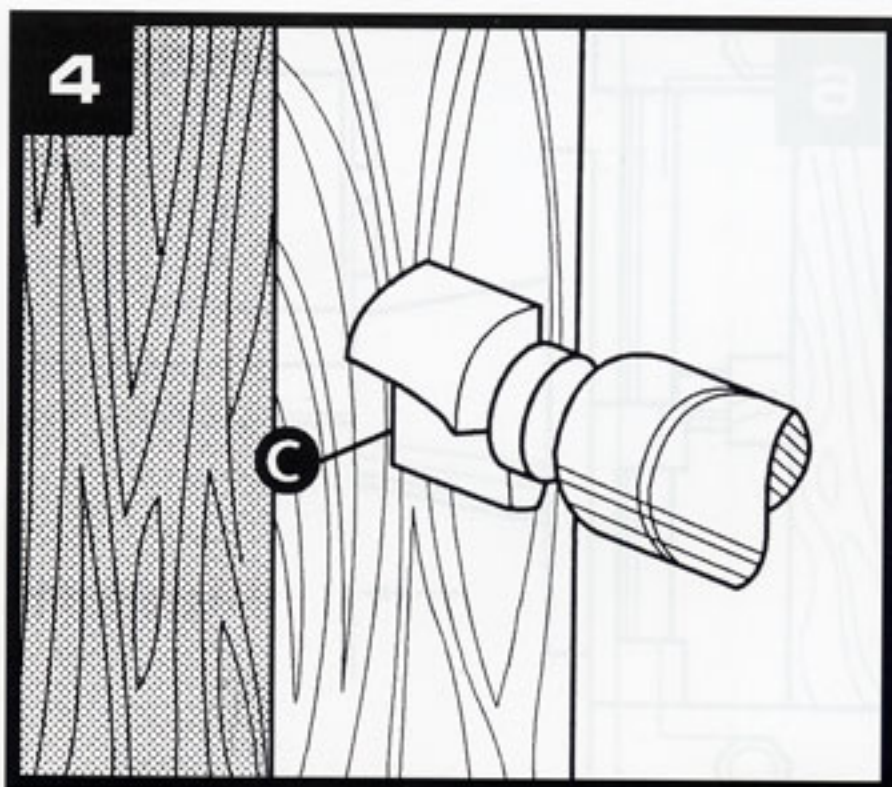

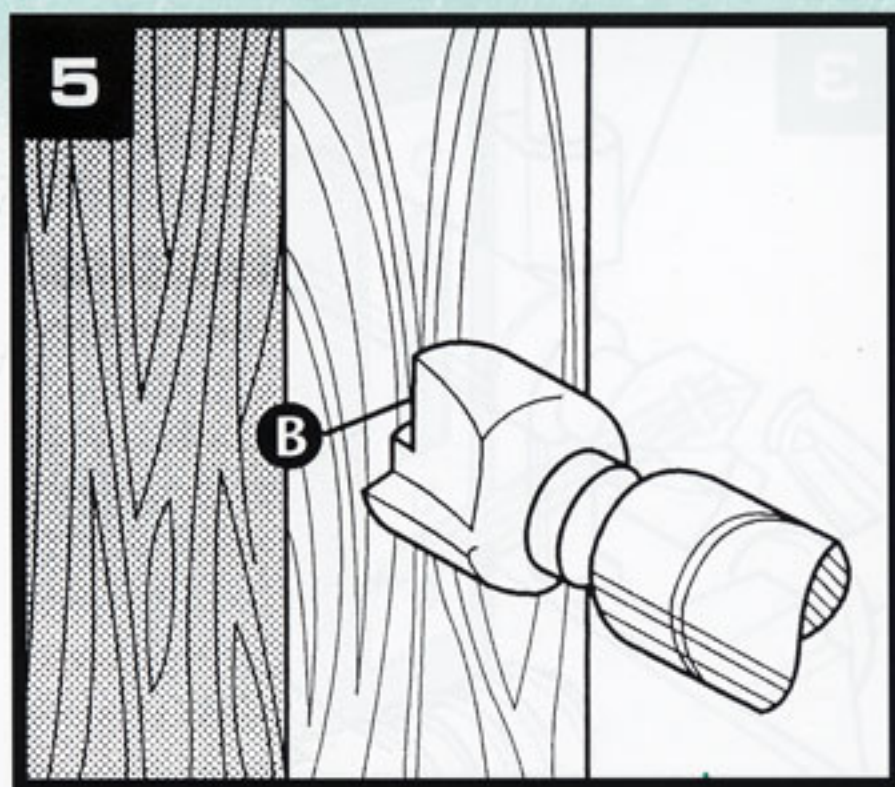

Slide the housing assembly upward to the upper lock body mark (position B). The cutter should now overlap this mark by about  $\frac{3}{16}$ " or 5mm. Bring the upper pair of clamps to rest on the housing and tighten the clamps. Check overall movement.

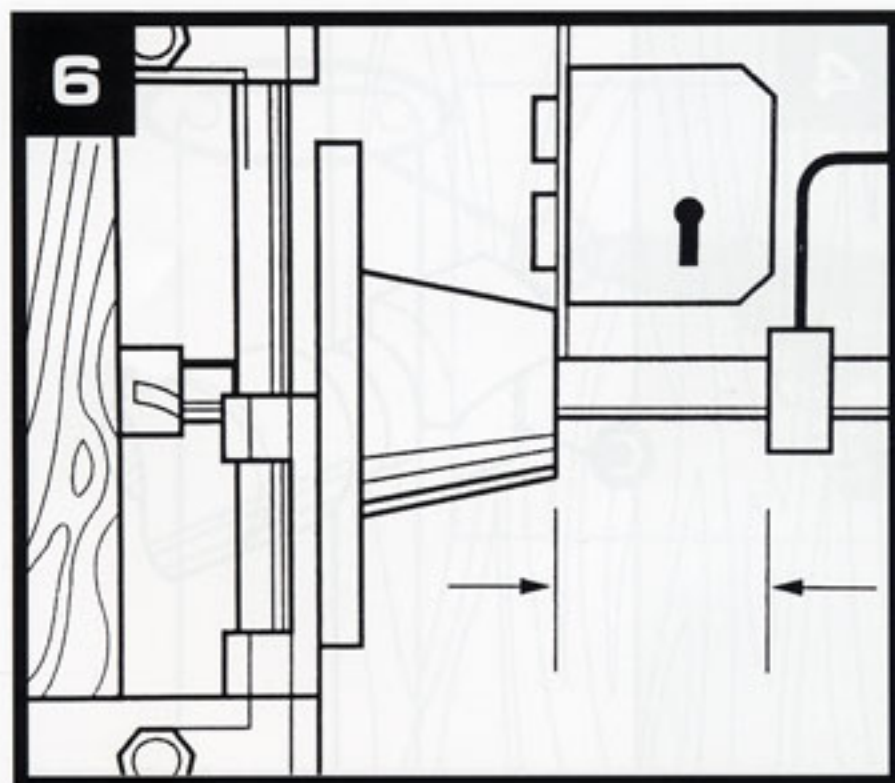

Set the collar on the cutter shaft to the depth of mortise required. (1 set screw). Do NOT over-tighten. Put on safety goggles.

Connect the electric drill to the cutter shaft. Select the fastest available speed. Turn on the drill. Hold the housing assembly with one hand and feed the cutter into the door. Clear wood-chips as you proceed to drill.

*Note: A smaller number of shallow cuts will provide a better result than one deep cut. This also reduces the load on the bearings.*

Remove the cutter by depressing the white line on the collar on the end of the shaft and pulling the cutter away.

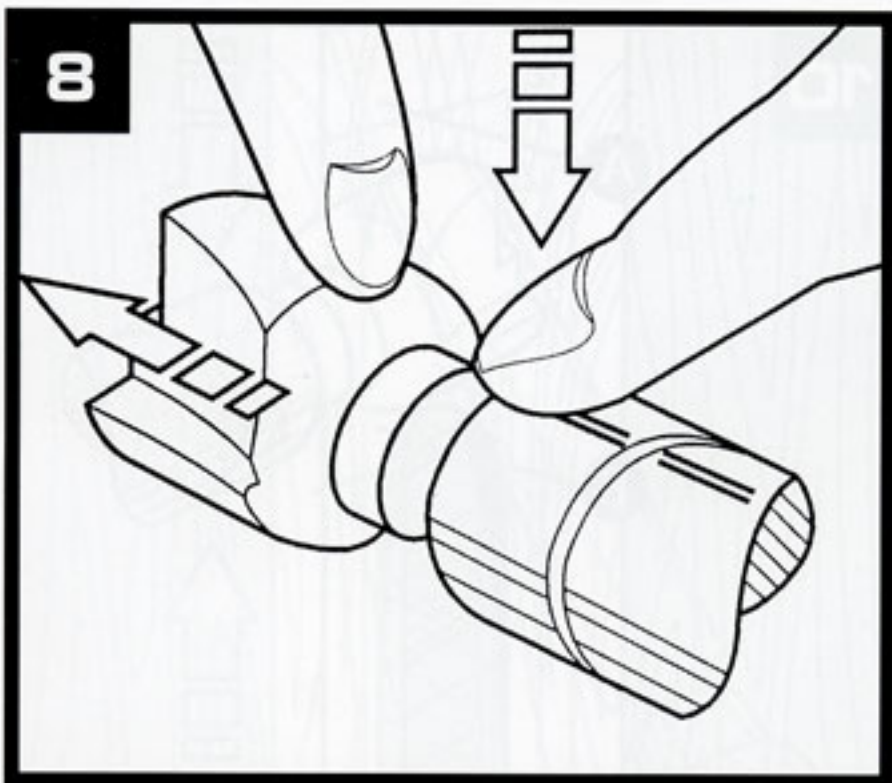
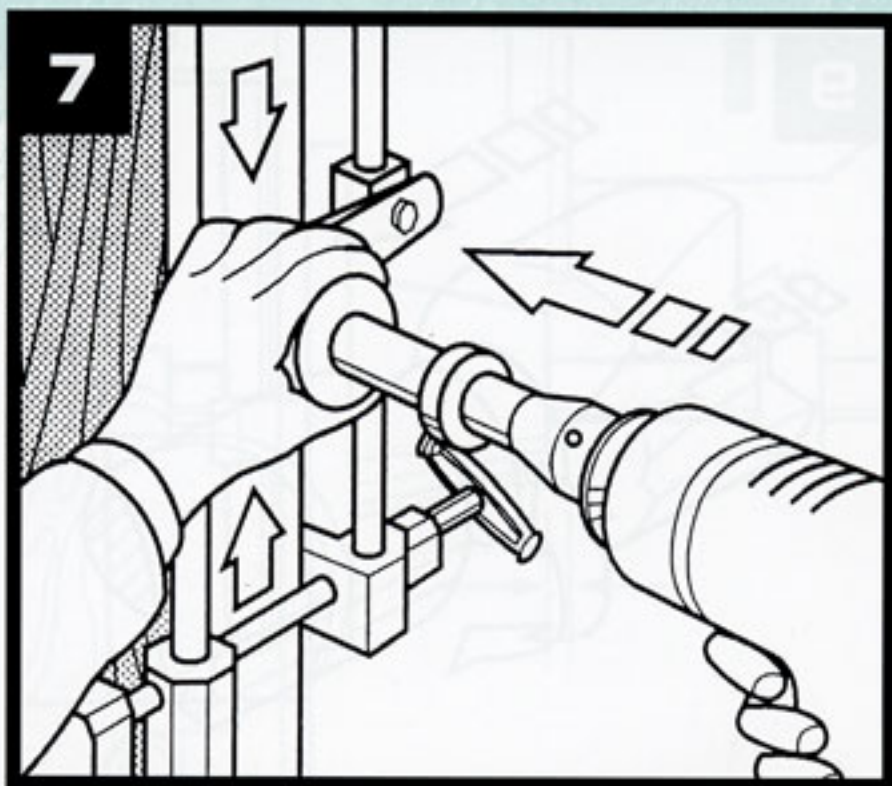

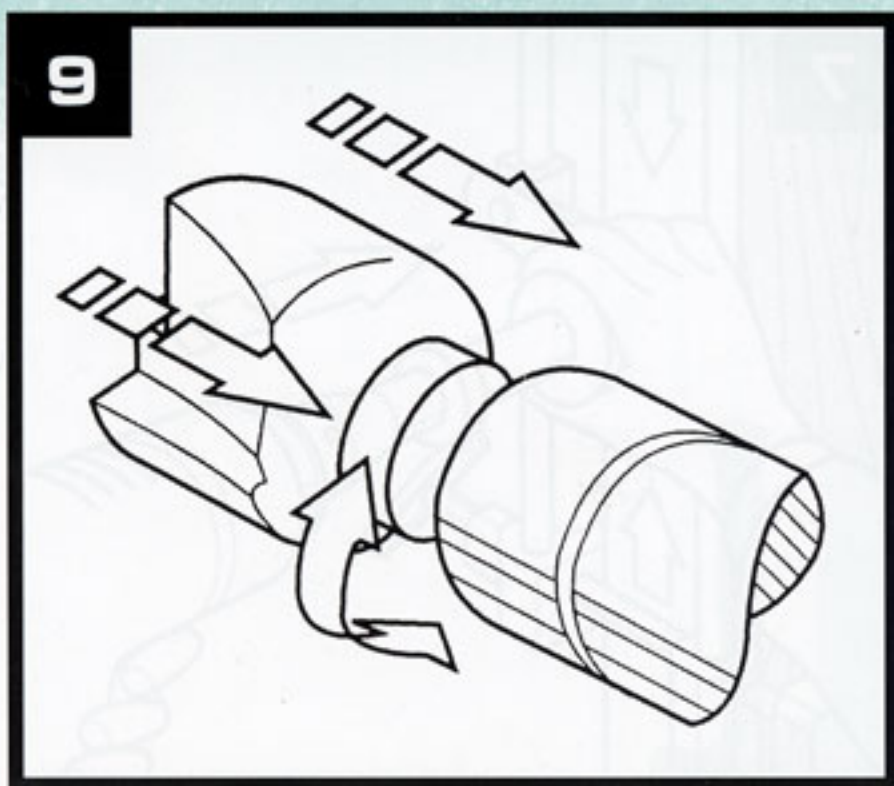

Select the appropriate cutter for the recess for the faceplate and place in front of the housing assembly. Push the shaft into the cutter until it “snaps” into place. Correct rotation of the cutter will aid insertion.

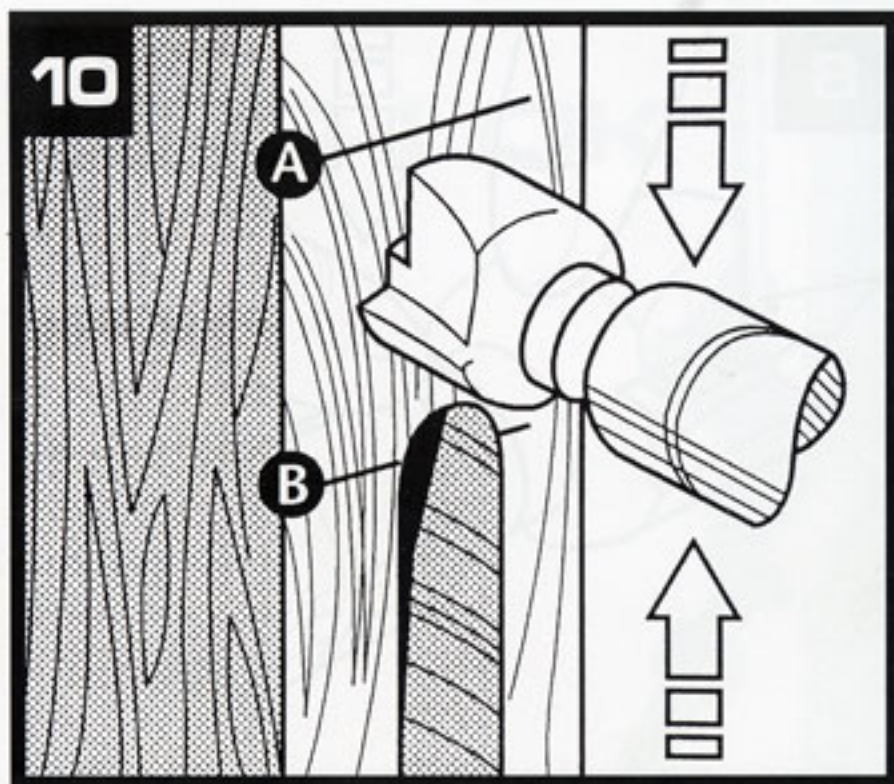

Move the top clamp to a position that allows the cutter to move within  $3/16$ " or 5mm below the top face plate mark (position A). Tighten the top clamp. Move the bottom clamp to a position that allows the cutter to move within  $3/16$ " or 5mm above the bottom face plate mark (position D). Tighten the bottom clamp.

Push the shaft so that the cutter strikes the door edge. Adjust the depth collar on the shaft to allow the cutter to make the recess for the faceplate. Tighten the setscrew on the depth collar.

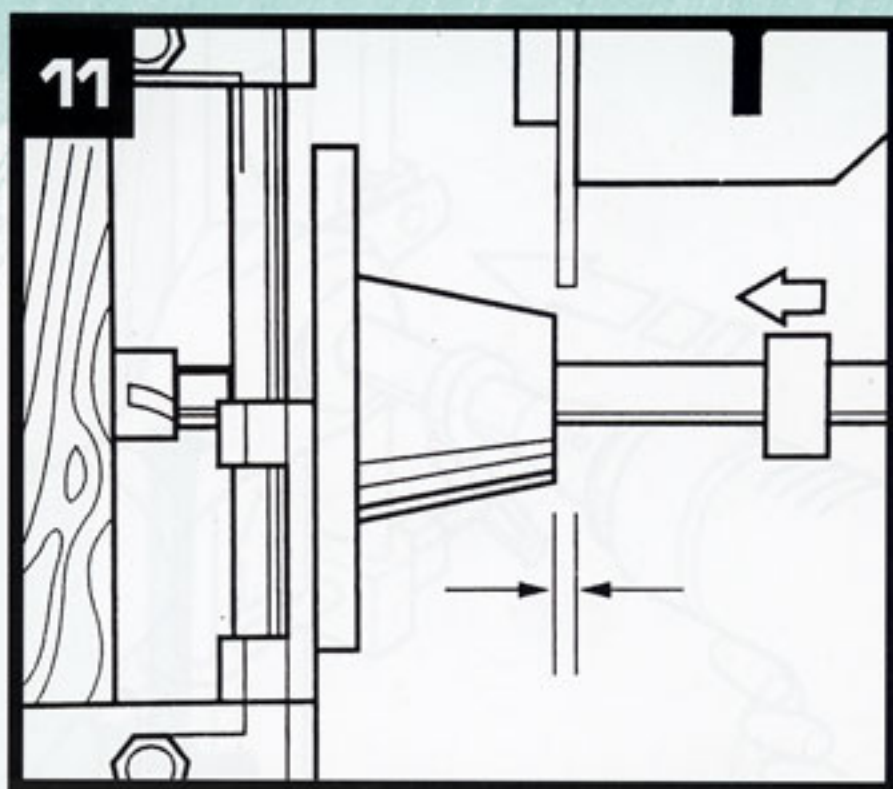

Neatly finish off the recess with a chisel. Install lock.

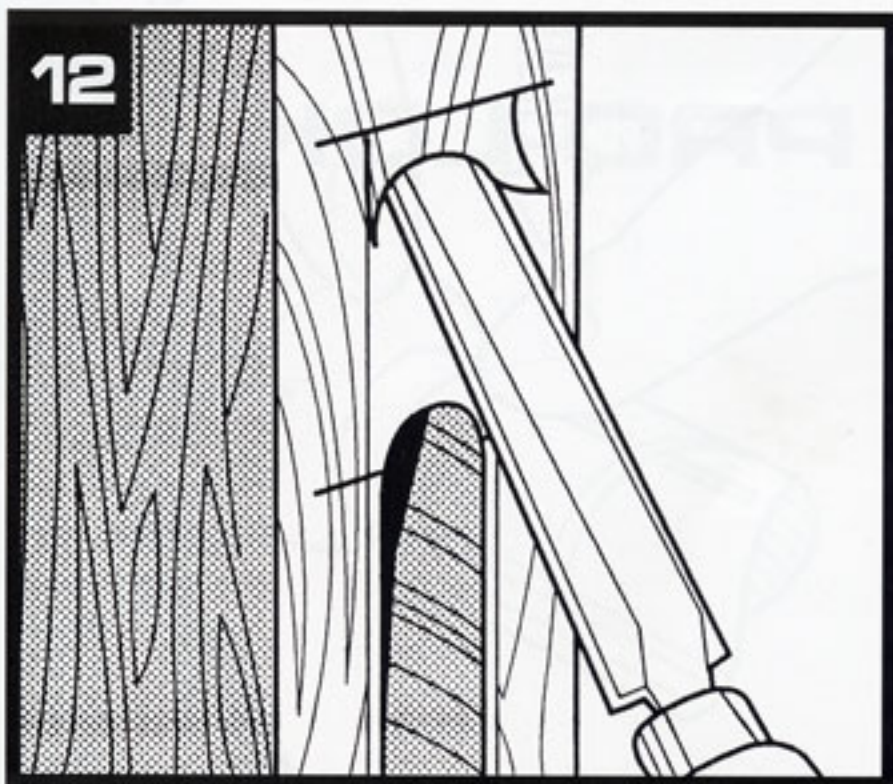

PRO-LOK



# Mortising Aluminum Doors



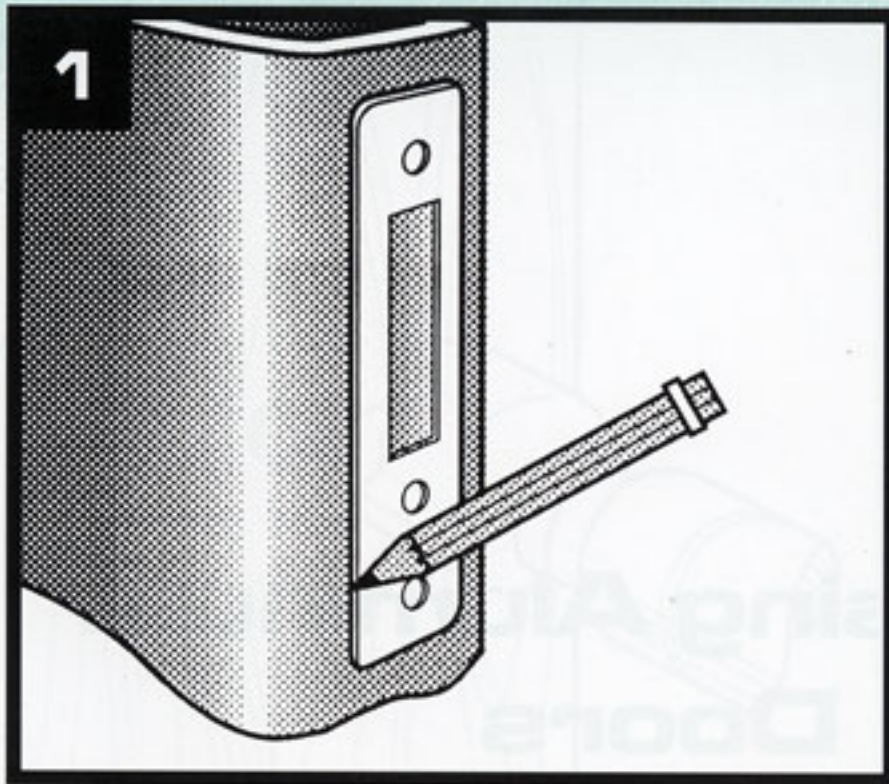

Remove the faceplate from lock. Place the faceplate on the door and draw or scribe around the faceplate.

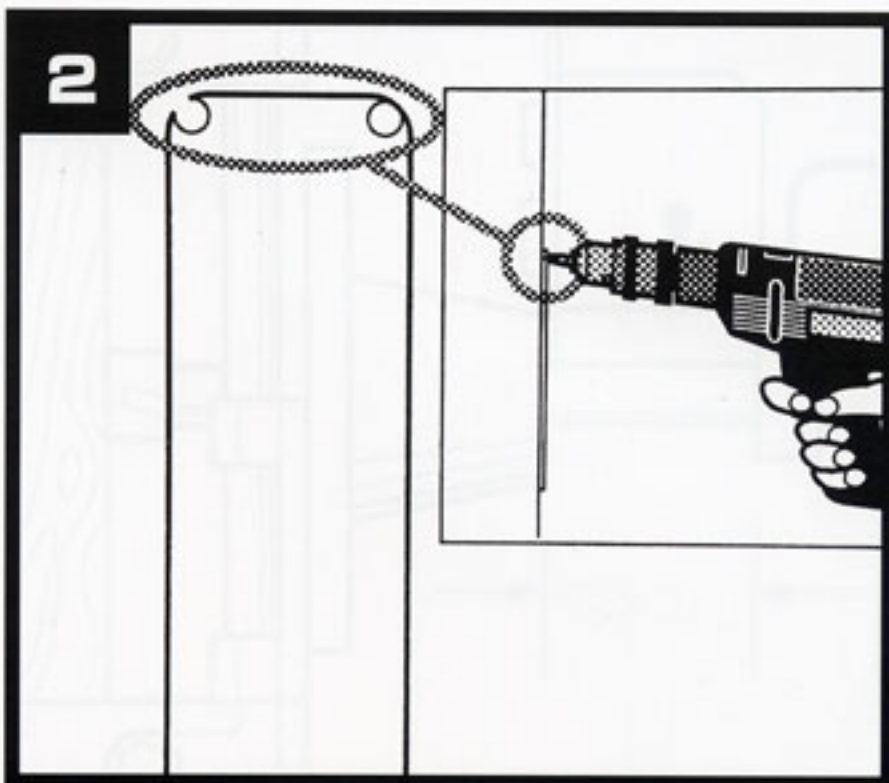

Use drills to correctly identify the radius of the faceplate corners. Then mark and drill a hole in each corner of the scribed outline.



Choose an aluminum cutter to suit the width of the faceplate. Push the cutter on the shaft until it locks on securely.

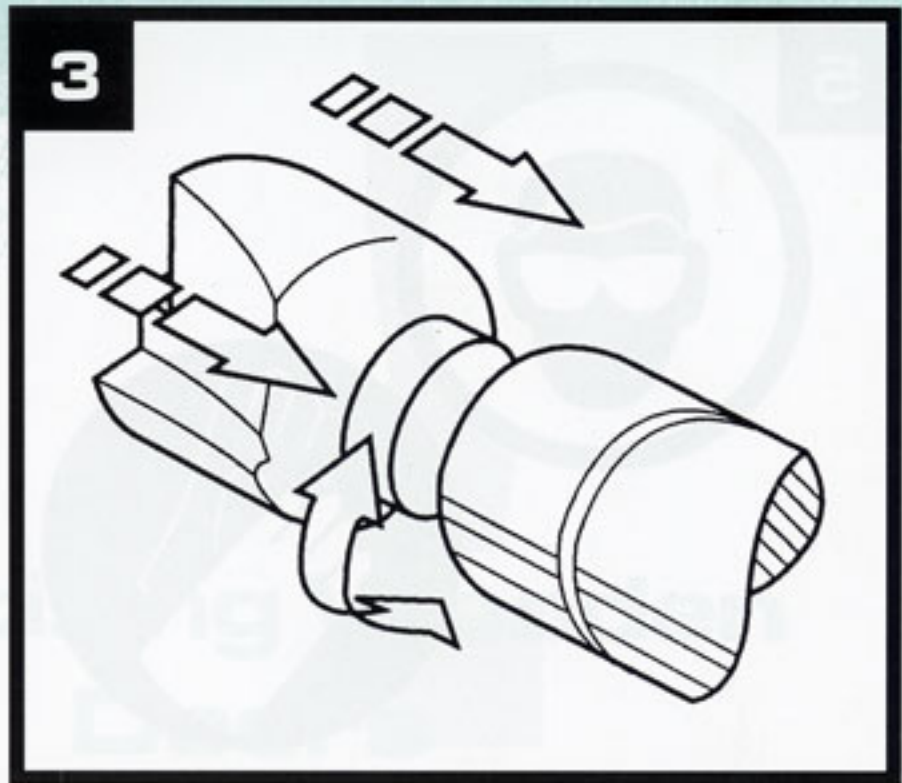

Put the shaft into the housing assembly and place on the door. Position the top and bottom clamps to allow the cutter to travel between the top and bottom scribe marks. Tighten both clamps securely.

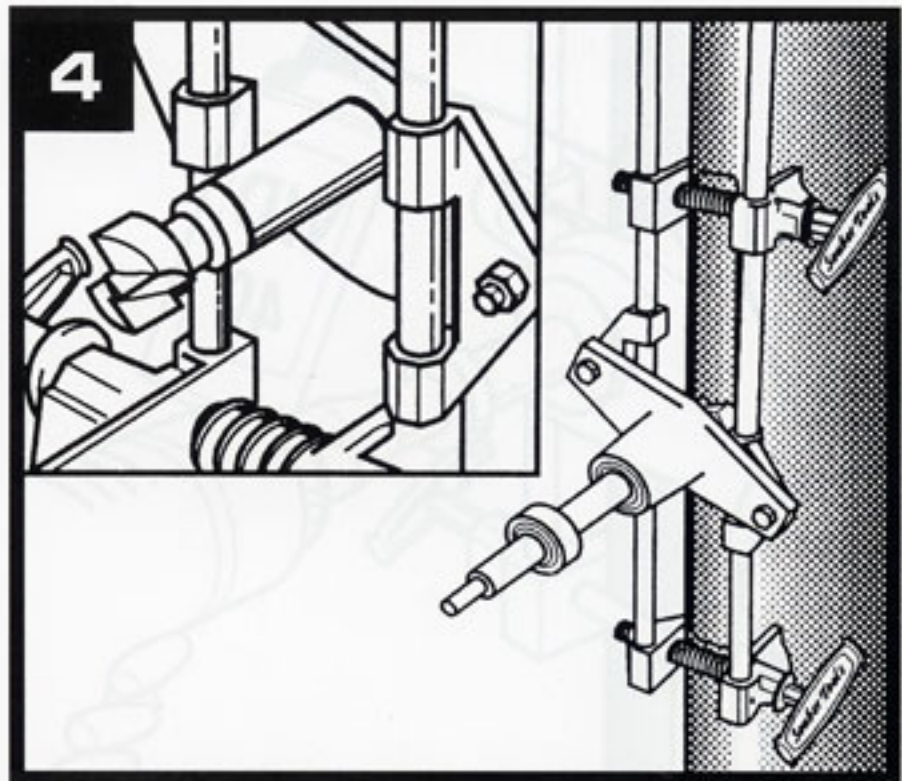



Put on safety goggles and gloves.

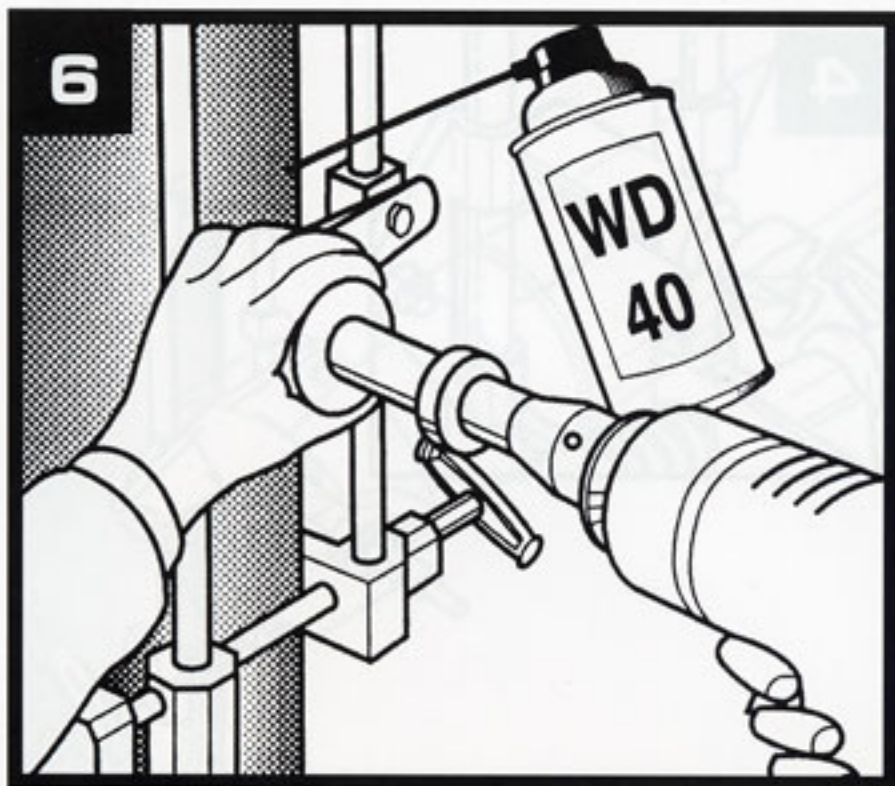

Attach drill to the cutter shaft and tighten the drill chuck securely. Spray door and cutter with WD40 or similar cutting lubricant.

Switch on drill. Lock the trigger at 2000-3000 RPM. Hold the housing assembly with one hand and feed the cutter into the door. Move the shaft housing up and down at a rate of 20x per minute while cutting the door surface. **DO NOT TRY TO DRILL AT ONE POSITION.**

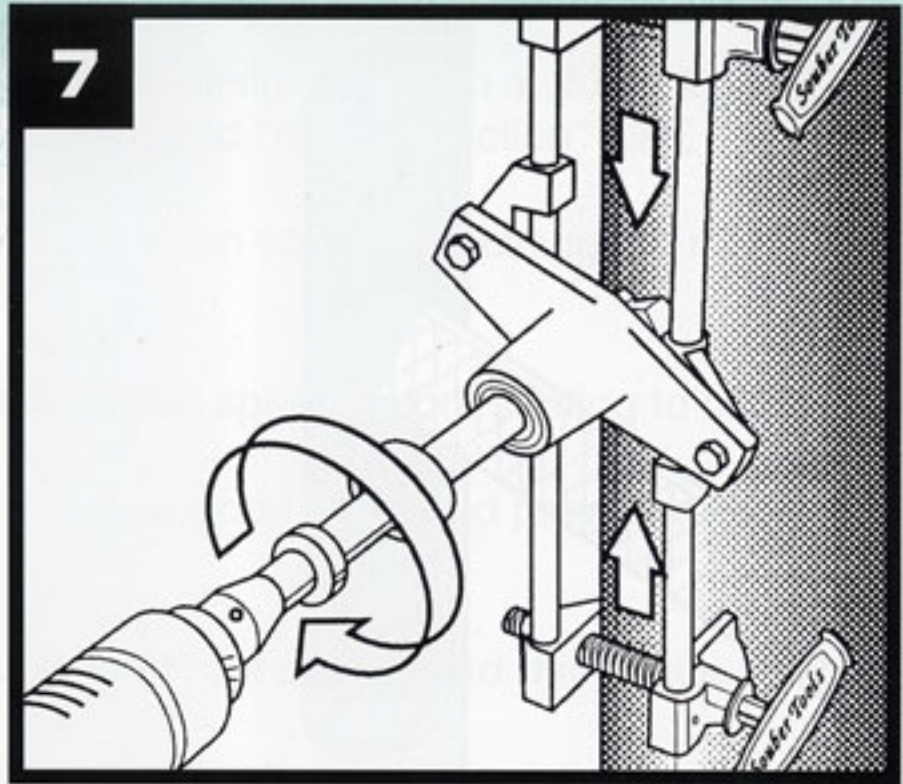

Eventually, the cutter will break through the aluminum section. Continue to move the cutter up and down until the remaining section is 20/1000" or 0.5mm or less. Only at that point should the cutter be allowed to travel inside the pierced door section. To ignore this instruction could cause a danger to the user and the cutter.

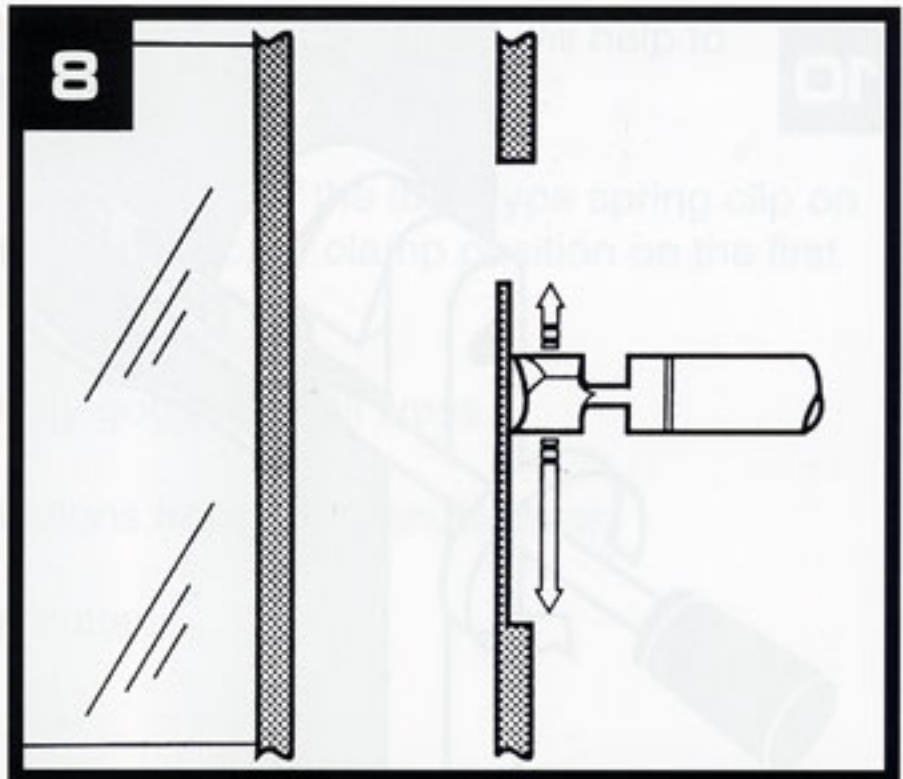

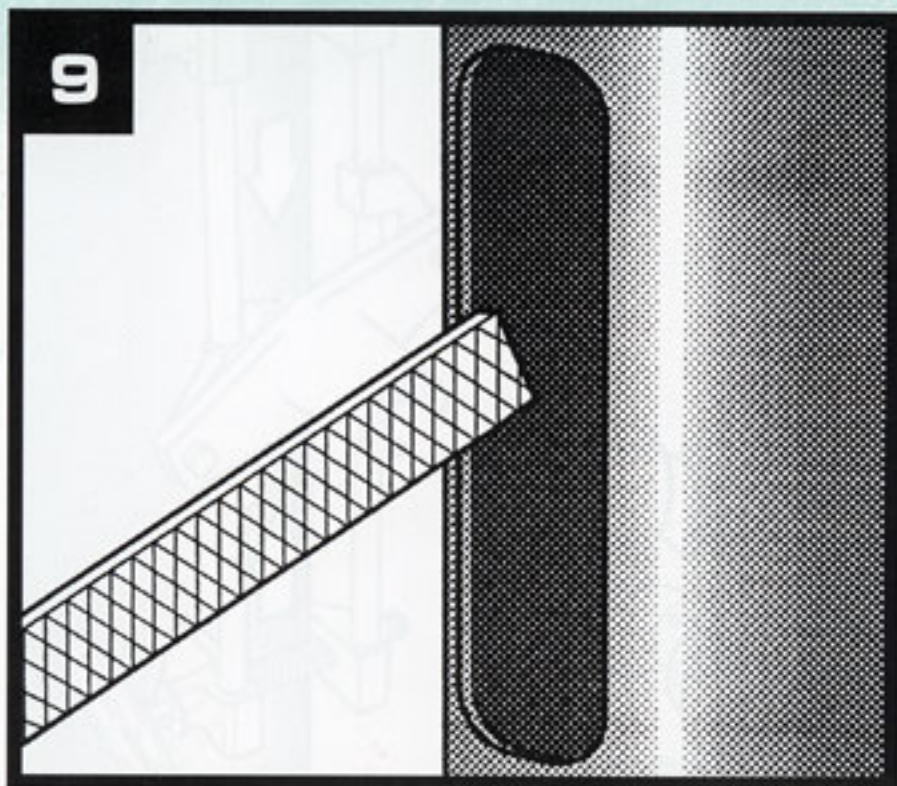

Use a dremel or hand-file to finish off the hole.

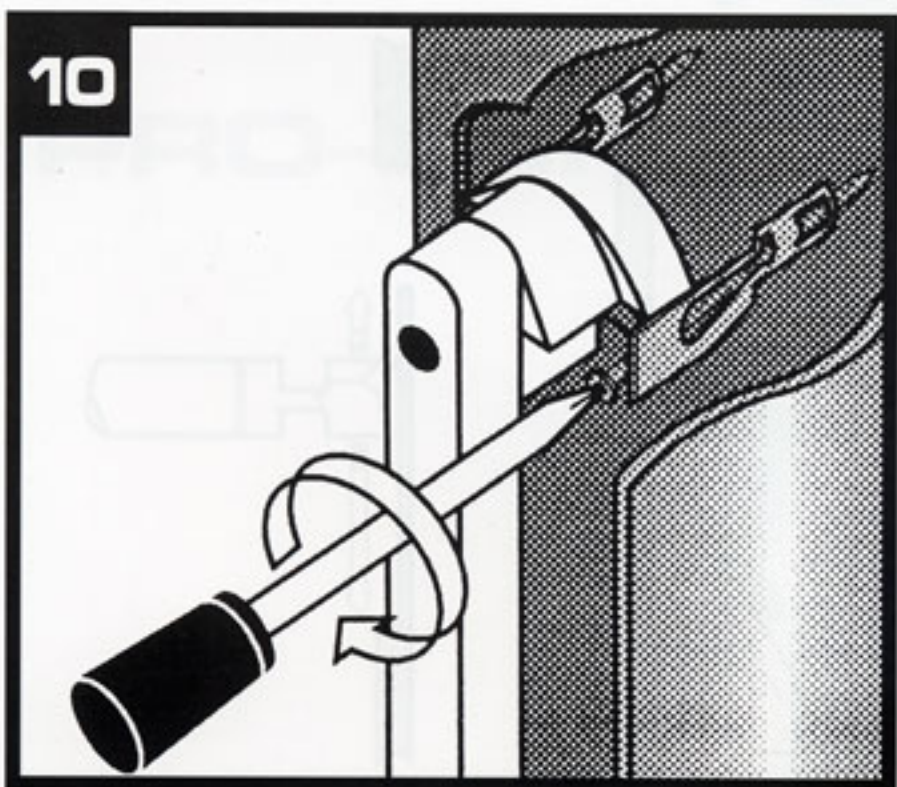

Fit the lock using "Adams Rite style" bridges as illustrated.

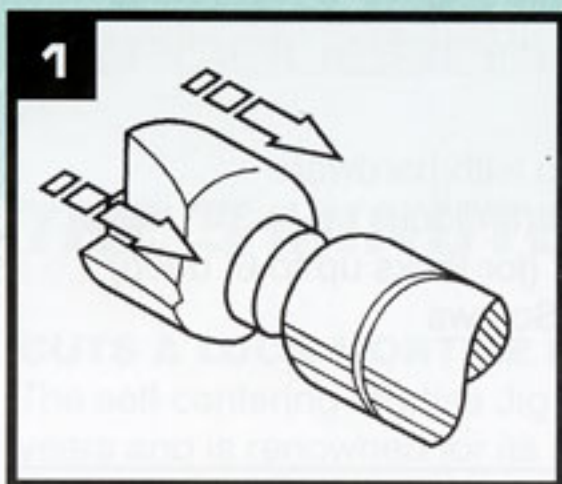

**SHARPENING THE CUTTER**

Insert the cutter onto the shaft.  
(See Photo 1)

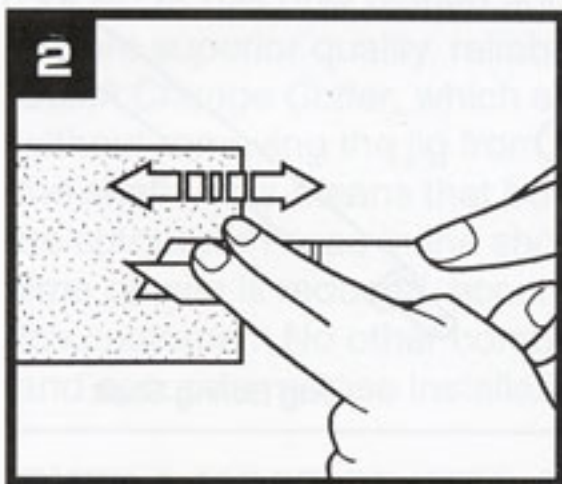

Place the cutter flat on an oiled sharpening stone and stroke the cutter back and forth with even pressure, sharpening both faces equally. (See Photos 2/3)

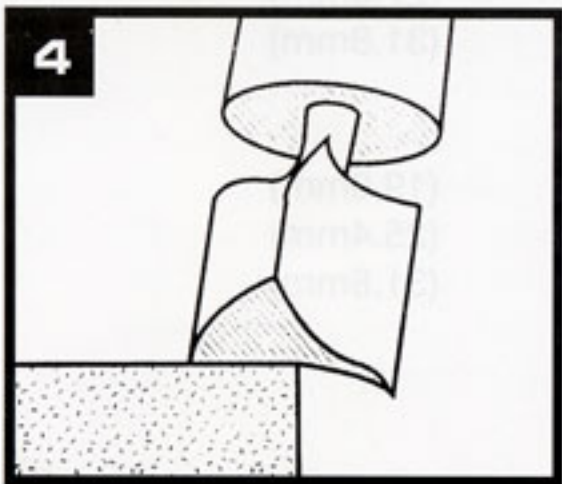
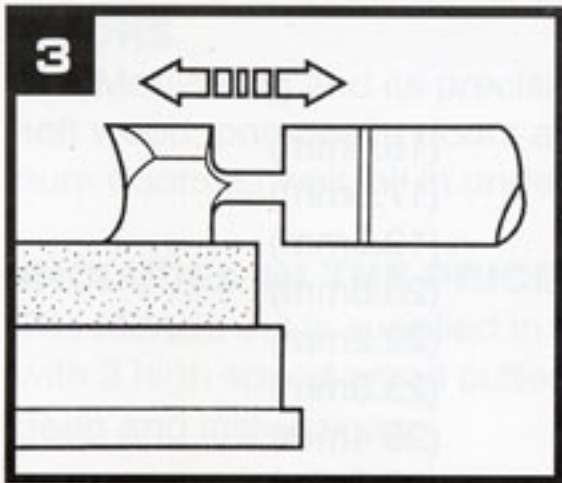

Place the cutter end on the edge of the oiled sharpening stone and position the shaft at an angle to allow the tip to be sharpened as in the previous operation. (See Photo 4)

**REPLACEMENT PARTS**

- INJIG-MORT-HK Aluminum Housing with hardware
- INJIG-MORT-SS Short Boring Shaft (for locks up to 3<sup>1/2</sup>" deep)
- INJIG-MORT-LS Long Boring Shaft (for locks up to 6" deep)
- INJIG-MORT-GS Set of 6 Allen Set Screws
- INJIG-MORT-CC Carrying Case

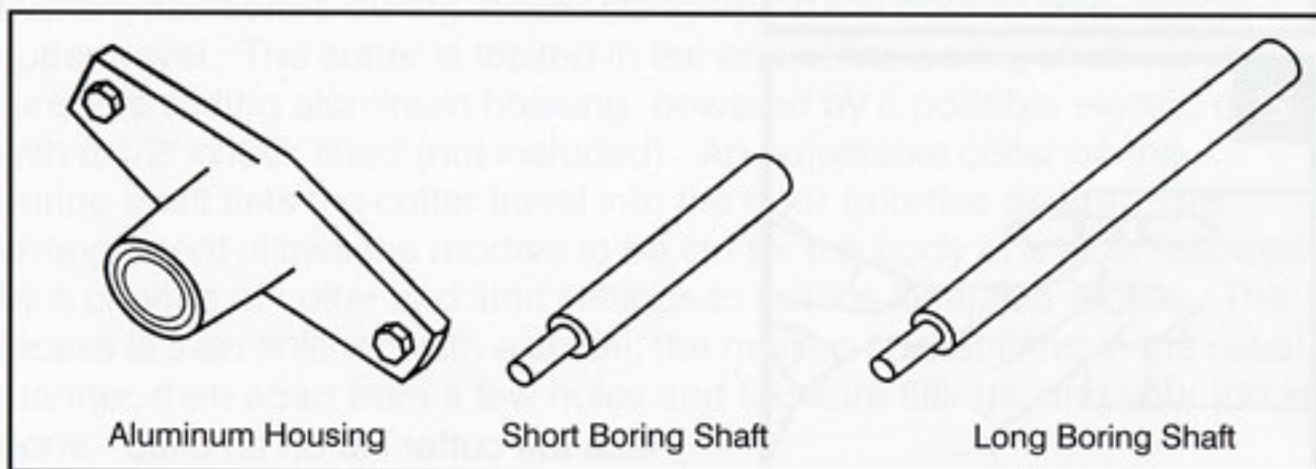

Aluminum Housing

Short Boring Shaft

Long Boring Shaft

**REPLACEMENT WOOD CUTTERS**

INJIG-MORT-WB16	5/8"	(16.0mm)
INJIG-MORT-WB18	11/16"	(17.5mm)
INJIG-MORT-WB19	3/4"	(19.0mm)
INJIG-MORT-WB21	13/16"	(20.6mm)
INJIG-MORT-WB22	7/8"	(22.2mm)
INJIG-MORT-WB24	15/16"	(23.8mm)
INJIG-MORT-WB25	1"	(25.4mm)
INJIG-MORT-WB27	1 1/16"	(27.0mm)
INJIG-MORT-WB32	1 1/4"	(31.8mm)

**ALUMINUM CUTTERS**

INJIG-MORT-AB19	3/4"	(19.0mm)
INJIG-MORT-AB25	1"	(25.4mm)
INJIG-MORT-AB32	1 1/4"	(31.8mm)

NOTES:



**PRO-LOK®**

655 N Horton Street, Orange CA 92668 • tel (714)633-0681 fax: (714) 633-0470

**INJIG-MORT**

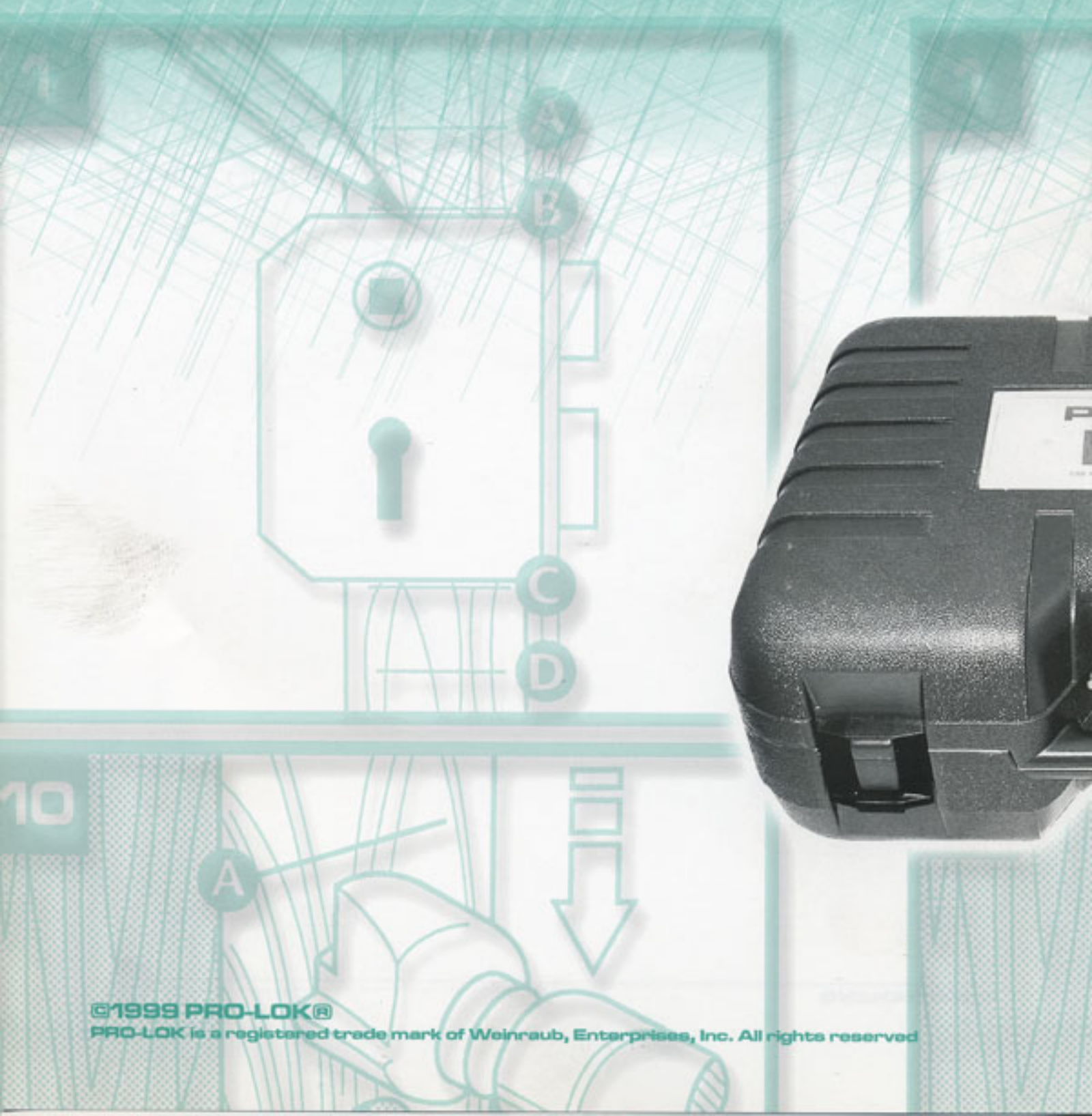

10

©1999 PRO-LOK®

PRO-LOK is a registered trade mark of Weinraub, Enterprises, Inc. All rights reserved