

Model 410/415 Installation Instructions

The model 410/415 has a tubular, deadlocking, mortice latch and may be used as a new installation on a door, or where an existing latch is to be replaced.

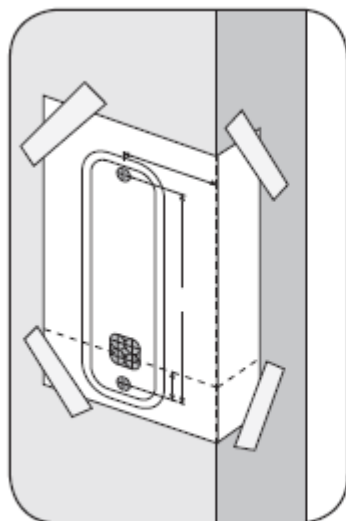

Step 1

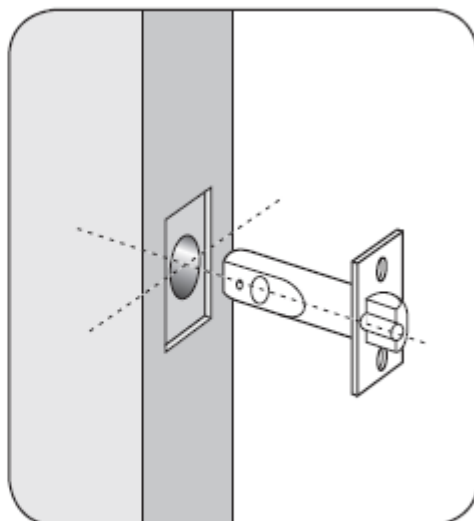

Step 2

Step 1

Lightly mark a height line on the edge and both faces of the door, and on the door jamb, to indicate the top of the lock when fitted.

Crease the template along the 'fold along the door edge' dotted line that suits your latch backset, and tape it to the door.

Mark the 2 x 10mm ($\frac{3}{8}$ ") and the 4x 16mm ($\frac{5}{8}$ ") holes. Mark the centre of the door edge centre line of latch. Remove the template and apply it to the other side of the door, aligning it accurately with the first central line of latch. Mark the 6 holes again.

Step 2

Keeping the drill level and square to the door, drill a 25mm hole to accept the latch.

Step 3

Keeping the drill level and square to the door, drill the 10mm ($\frac{3}{8}$ ") and 16mm ($\frac{5}{8}$ ") holes from both sides of the door to increase accuracy and to avoid splintering out the door face. Clear a 32mm square hole from the 4 x 16mm holes.

Step 4

Put the latch into the hole and, holding it square to the door edge, draw around the faceplate. Remove the latch and score the outline with a Stanley knife to avoid splitting when chiselling. Chisel a rebate to allow the latch to fit flush to the surface.

Step 5

Fix the latch with the wood screws, with the bevel towards the door frame.

Step 6

Fitting the strike plate.

Note: The plunger beside the latchbolt deadlocks it, to protect against manipulation or 'shimming'. The strike plate must be accurately installed so that the plunger CANNOT enter the aperture when

the door is closed, even if it is slammed shut. Position the strike plate on the door frame so that it lines up with the flat of the latchbolt, and NOT the plunger.

Mark the positions of the fixing screws, and draw around the aperture of the strike plate. Chisel out the aperture 15mm deep to receive the latchbolt. Fix the strike plate to the surface of the frame using only the top fixing screw. Gently close the door and check that the latchbolt enters the aperture easily, and is held without too much 'play'. When satisfied, draw around the outline of the strike plate, remove it and cut a rebate to enable the faceplate to lie flush with the surface. Re-fix the strike plate using both screws.

Step 7

Check that the lever handles are correctly fitted for the hand of door. To change the hand of a lever handle, loosen the grub screw with the small Allen key, reverse the lever handle and fully tighten the grub screw.

Step 8



For door hung on RIGHT fit silver spindle on code side.



For door hung on LEFT fit coloured spindle on code side.



Fit the butterfly spindle to the inside, non-code side.

Step 9

Fit latch support post into back of the code side front plate according to the hand of your door, A for a right hand door, or B for a left hand door (see diagram).

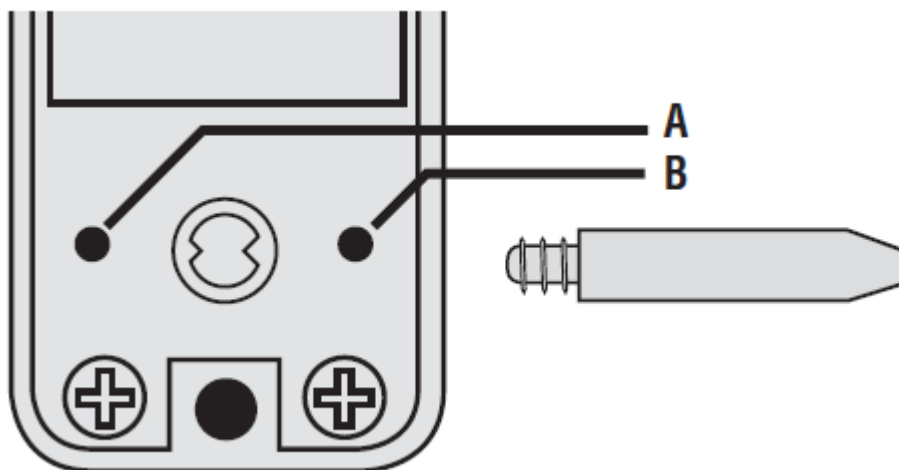

Step 10

Cut two of the fixing bolts to the required length for your door. Approximate overall length should be door thickness plus 20mm ($\frac{13}{16}$ "") to allow about 10mm ($\frac{3}{8}$ "") of threaded bolt to enter the outside plate.

Step 11

Apply the front and back plates, with the neoprene seals in position, against the door, over the protruding ends of the spindle.

Step 12

Fix the two plates together using the fixing bolts, starting with the top fixing. Ensure that the two plates are truly vertical and then tighten the bolts. Do not use excessive force.

Step 13

Before closing the door, enter the code and ensure that the latchbolt will retract when the lever handle is depressed. Now check the operation of the inside lever handle. If there is any binding of the handles or latch then loosen the bolts slightly and reposition the plates slightly until the correct position is found, and then re-tighten the bolts.