

FUTURA **PRO** ONE

FUTURA **PRO** ONE ABUS®

Operating Manual

Original Instructions

D446729XA

vers. 3.0

CE

EN



(c) 2016 SILCA S.p.A. - Vittorio Veneto

This manual has been drawn up by SILCA S.p.A.

All rights reserved. No part of this publication can be reproduced or circulated by any means whatsoever (photocopies, microfilm or other) without the consent of SILCA S.p.A.

Edition: January 2018

Printed at Vittorio Veneto

Da SILCA S.p.A.

Via Podgora, 20 (Z.I.)

31029 VITTORIO VENETO (TV) - Italy

The Manufacturer declines any responsibility for possible inaccuracies in this document due to printing or transcription errors. The Manufacturer reserves the rights to alter the information without prior notice, except when they affect safety. This document or any of its parts cannot be copied, altered or reproduced without written authorization from the Manufacturer. Keep the manual and look after it for the entire life cycle of the machine. The information has been drawn up by the manufacturer in his own language (Italian) to provide users with the necessary indications to use the key-cutting machine independently, economically and safely.

IMPORTANT NOTE: in compliance with current regulations relating to industrial property, we hereby state that the trade-marks or trade names mentioned in our documentation are the exclusive property of authorized manufacturers of locks and users. Said trade-marks or trade names are nominated only for the purposes of information so that any lock for which our keys are made can be rapidly identified.

® Registered Trademark

INDEX

USE OF THE MANUAL	1
GENERAL WARNINGS	4
1 MACHINE DESCRIPTION	5
1.1 MAIN OPERATING PARTS	6
1.2 SAFETY	7
1.3 TECHNICAL DATA.....	8
1.4 ACCESSORIES PROVIDED.....	9
2 HANDLING.....	10
2.1 PACKING.....	10
2.2 UNPACKING.....	10
2.3 HANDLING THE MACHINE	10
3 MACHINE INSTALLATION AND PREPARATION.....	11
3.1 CHECKING FOR DAMAGE.....	11
3.2 ENVIRONMENTAL CONDITIONS.....	11
3.3 POSITIONING	11
3.4 SEPARATE PARTS	12
3.4.1 TABLET STAND AND TABLET.....	12
3.4.2 POWER PACK AND LEAD.....	13
3.4.3 FIXING BRACKET.....	13
3.5 WORK STATION DESCRIPTION	14
4 TABLET REGULATION AND USE	15
4.1 CHOICE OF LANGUAGE.....	15
5 CLAMP FOR DIMPLE AND TRACK KEYS - 01R.....	16
5.1 FITTING THE KEY	16
5.1.1 DIMPLE KEYS.....	16
5.1.2 TRACK TYPE KEYS.....	17
5.2 REMOVING / FITTING CLAMP 01R	17
5.3 REMOVING/FITTING THE JAWS ON CLAMP 01R	18
5.4 USING TRACER 01T.....	19
5.5 TRACER 02T.....	19
5.6 ENGRAVING	20
6 CLEANING.....	23
7 MAINTENANCE	24
7.1 OPERATIONS	24
7.2 ACCESS TO REAR COMPARTMENT	24
7.3 CUTTER AND/OR TRACER POINT REPLACEMENT.....	25
7.4 TRACER 01T REPLACEMENT.....	25
7.5 CHECKING AND REPLACING FUSE.....	26
7.6 BATTERY REPLACEMENT.....	27
8 DISPOSAL	28
9 ASSISTANCE.....	29
9.1 HOW TO REQUEST SERVICE.....	29
10 SOFTWARE OPERATING GUIDE.....	30
11 ELECTRICAL DIAGRAMS	31

CE DECLARATION

USE OF THE MANUAL

This manual has been drawn up by the Manufacturer and is an integral part of the machine literature. The manual gives information that is obligatory for the operator to know and which makes it possible to use the machine safely.

User's Manual

This user's manual is provided because it is essential for proper use and maintenance of the machine. The manual must be kept carefully throughout the life of the machine, including the decommissioning stage. Keep in a dry place close to the machine where it is always to hand for the operator.



IT IS OBLIGATORY to read the manual carefully before using the machine.

Readers' characteristics

This manual must be read and its contents acquired by those who will use it.

Manufacturer's ID

FUTURA PRO ONE has an ID plate located on the back of the machine, showing the serial number.

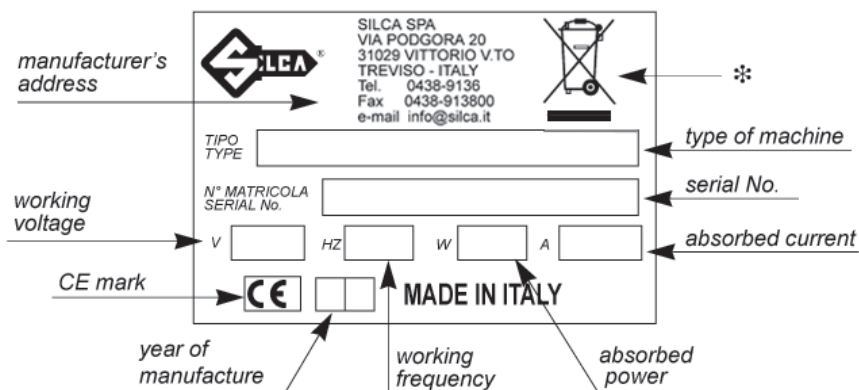

Fig. 1

(*) see chap. 8 DISPOSAL.

How to apply for after-sales service

Silca provides purchasers of FUTURA PRO ONE with After-Sales Service.

For the total safety of the operator and machine, any operation not described in the manual must be carried out by the manufacturer or in the special Service Centers recommended by Silca.

At the end of the manual there is a list of manufacturers' and authorized Service Centre addresses; if the manual was downloaded is necessary visit the website to see the contacts (www.silca.biz).

The warranty card attached to the machine covers free repairs or replacement of faulty parts for 24 months from the date of purchase*. All operations must be agreed by the user with Silca or the Service Center.

* Damage caused by negligence or wrong use of the machine by the user will null the warranty.

TERMINOLOGY

For those inexperienced in the subject of keys and key cutting, below is an illustration of the most frequently used terms:

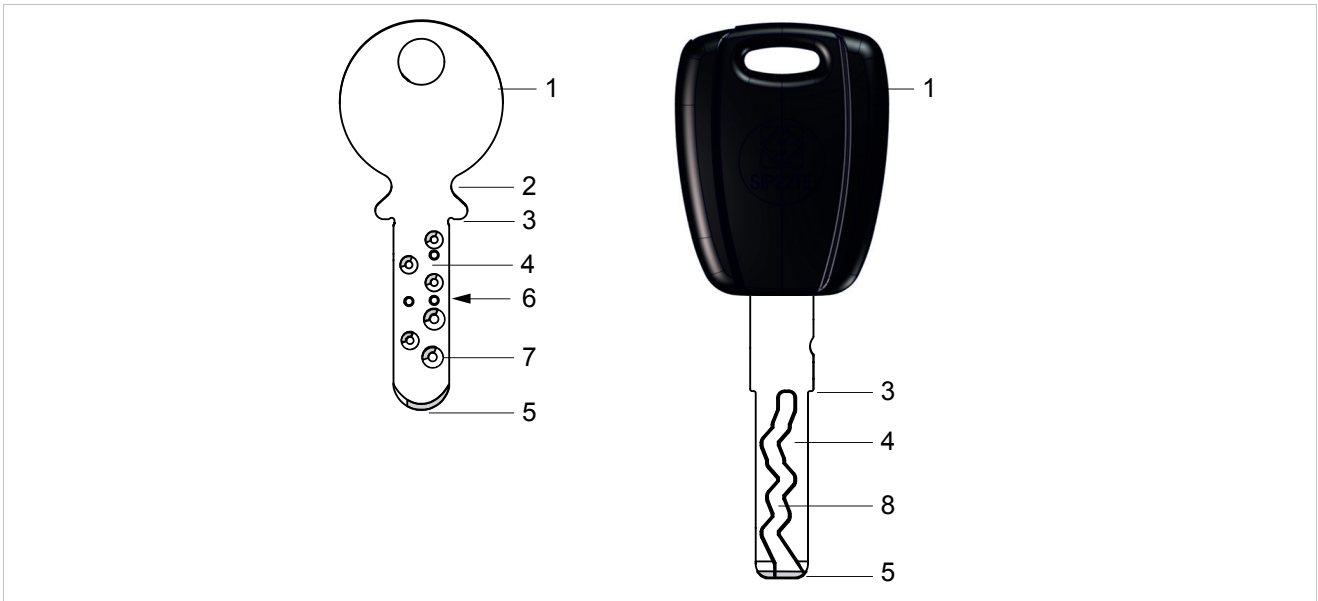



Fig. 2



1) Head	3) Shoulder stop	5) Tip	7) DIMPLE cutting
2) Neck	4) Blade (stem)	6) Back	8) TRACK cutting

ATTENTION: anodised aluminium dimple/laser keys, plastic keys or any other key without electrical conductivity CANNOT BE decoded! For these types of keys digit the cuts directly or enter the indirect code if the SSN in use allows it.

GRAPHICS IN THE MANUAL

	
Pay attention	Obligation to read the manual

GRAPHICS ON THE FUTURA PRO ONE KEY-CUTTING MACHINE

		
Do not clean with compressed air	Obligation to read the manual	Adhesive label Mass - RPM

GENERAL WARNINGS

FUTURA PRO ONE is designed to the principles of European Standards (CE).

Right from the design stage solutions have been adopted to eliminate hazards for the operator in all the stages of use: handling, regulation, use and maintenance.

The materials used in manufacture and the components employed in using FUTURA PRO ONE are not dangerous and ensure that the machine complies to current standards.

Silca S.p.A. has also experimented and applied numerous technical solutions that allow the key-cutting machine to optimize the quality of the cut keys.

To guarantee maintaining these results over time, please follow the instructions below:

- **Observe the procedures described in this manual;**
- **Always use Original Silca Tools as they are designed to make the best of FUTURA PRO ONE and provide quality key-cutting;**
- **Use Silca/Ilco key blanks, made with top quality materials;**
- **Have the key-cutting machine checked periodically by an authorized Silca After-Sales Service Center (list at the end of this manual);**
- **Always use Silca Original Spare Parts. Beware of imitations!**

NORMAL USE

FUTURA PRO ONE is a key-cutting machine and must be installed and used according to the rules and specifications established by the manufacturer.

The FUTURA PRO ONE key-cutting machine is designed for use on business or industrial premises (e.g. hardware shops, key cutting centers, etc...).

Any other use different from that indicated in this manual will cause the forfeiture of all customers' rights to make claims on Silca S.p.A. and may be an unknown source of hazard for the operator or third parties.



ATTENTION: Negligent use or failure by the operator to observe the instructions in this manual are not covered by the warranty and the manufacturer declines any responsibility in such cases.

ATTENTION: Anodised aluminium keys, plastic keys or any other key without electrical conductivity CANNOT BE decoded!

RESIDUAL RISKS

No further risks will arise when properly using the FUTURA PRO ONE machine.

SAFETY REGULATIONS

- **Always disconnect the machine when it is not in use or when performing maintenance operations.**
- **Check the electrical wiring periodically; replace any wires that show signs of wear.**
- **Always work with dry hands free of grease or oil.**
- **Never tug on the electricity supply lead and make sure it is not in contact with oil or other liquids, sharp objects or heat. Never remove the grounding pin from the plug. Check that the ground wire is connected properly.**
- **Do not use the machine in dangerous environments (wet or damp).**
- **All visitors, especially children, must stay at a safe distance from the machine and must never come into contact with the electric wiring.**

1 MACHINE DESCRIPTION

FUTURA PRO ONE is an electronic machine operating on 3 axes with controlled movement. Accurately studied, it adds a high degree of cutting precision to operating speed and ease of use. **FUTURA PRO ONE operates only when connected to a TABLET containing a Silca program.** It uses a tracer to decode keys with dimple and/or track cuts.

It can cut keys (in ferrous materials in general, brass, silver nickel, etc.) having:

- Dimple cuts
- Track cuts
- Special cuts (e.g. Ford Tibbe - with optional accessory)
- Cuts on tubular keys (with optional accessory)

FUTURA PRO ONE is used to cut the following types of keys:

Keys with DIMPLE and/or TRACK CUTS

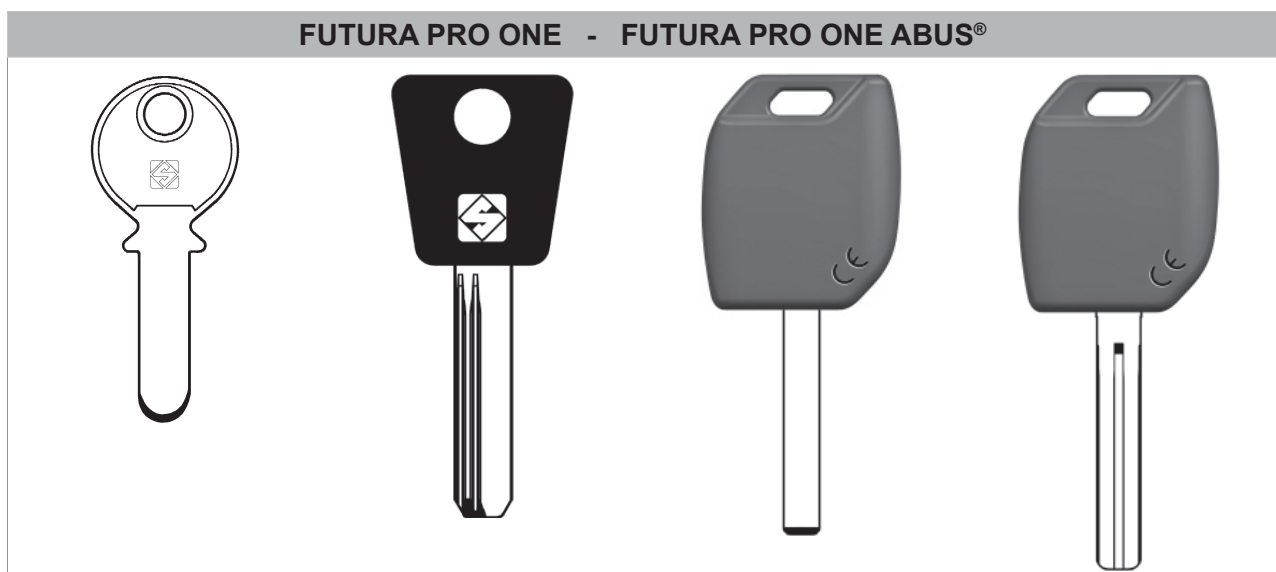

Fig. 3

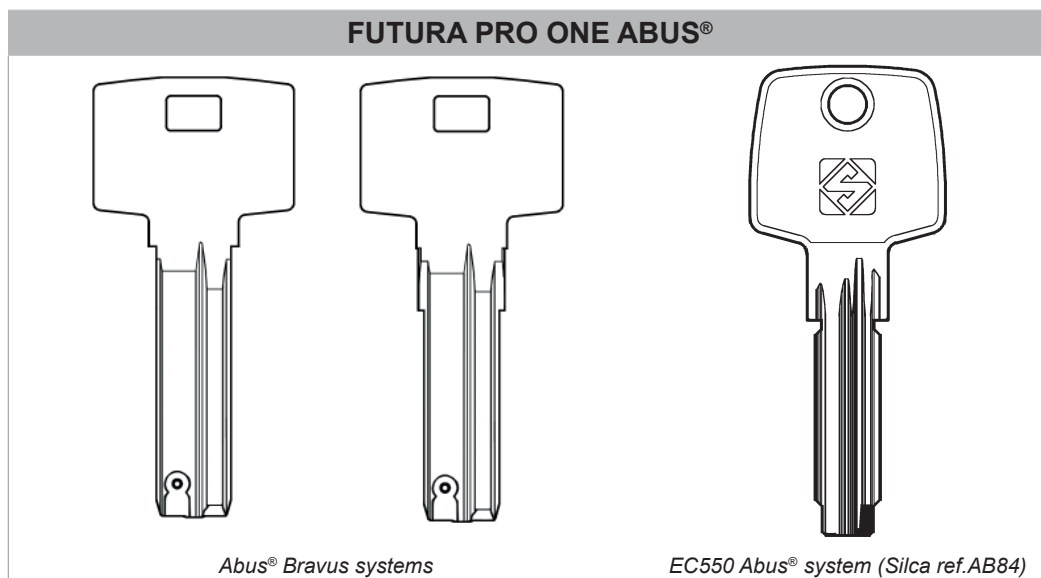

Fig. 4

ATTENTION: Anodised aluminium keys, plastic keys or any other key without electrical conductivity CANNOT BE decoded!

1.1 MAIN OPERATING PARTS

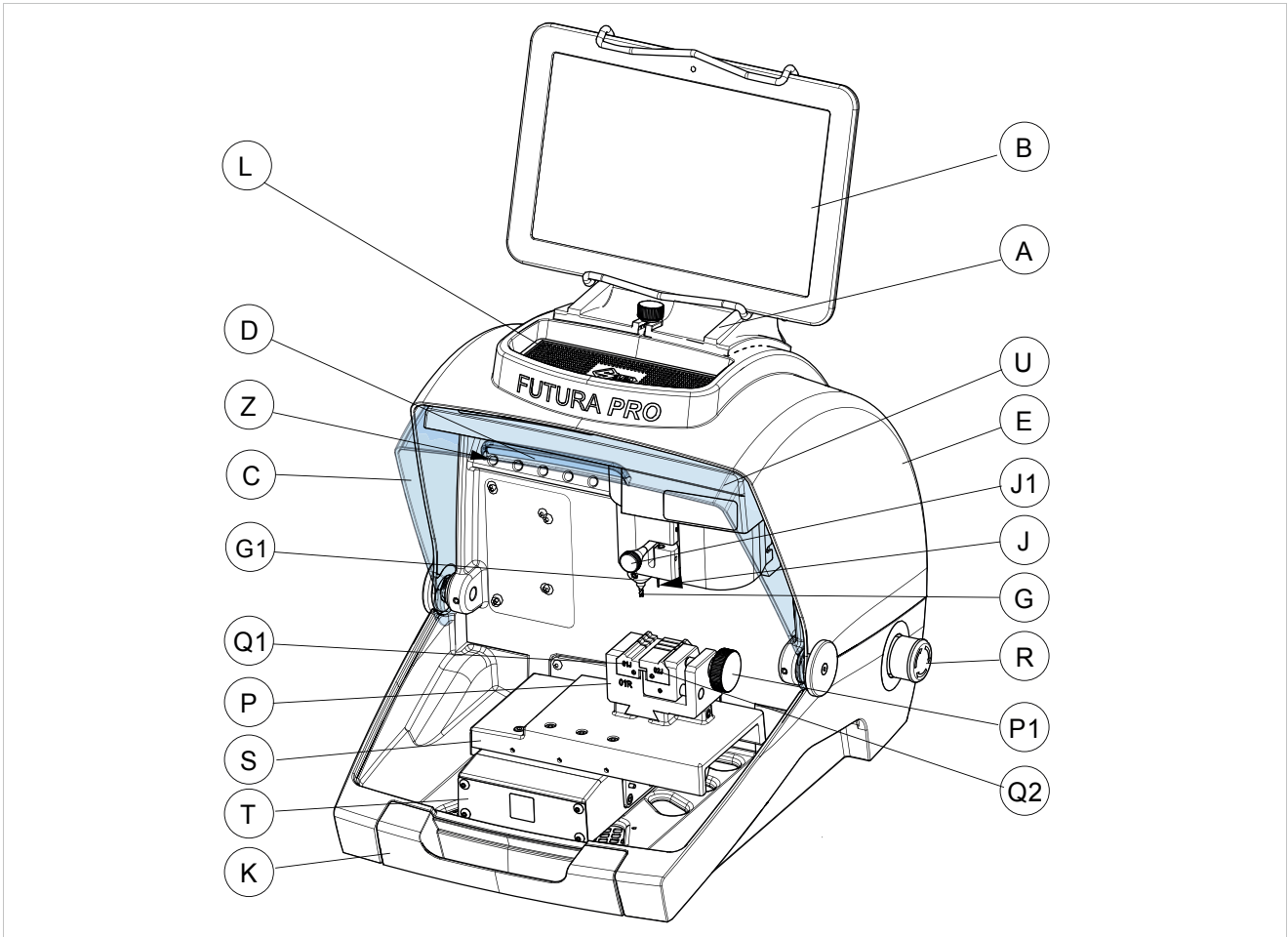

Fig. 5

- A - Tablet stand
- B - Tablet
- C - Safety shield
- D - Lamp
- E - Cover
- G - Cutter (Dimple/Track cuts)
- G1 - Cutter shaft (Dimple/Track cuts)
- J - Tracer 01T
- J1 - Tracer movement lever
- L - Tool compartment
- K - Swarf collection tray
- P - Clamp 01R (Dimple/Track cuts)
- P1 - Clamp knob (01R)
- Q1 - Left-hand jaw
- Q2 - Right-hand jaw
- R - ON/Emergency push button
- S - X axis carriage
- T - Y axis carriage
- U - Z axis carriage
- V - Ethernet port
- W - Power pack
- W1 - Power pack connector
- Y - USB port for Tablet charge
- Y1 - USB port standard
- Z - Tool holder

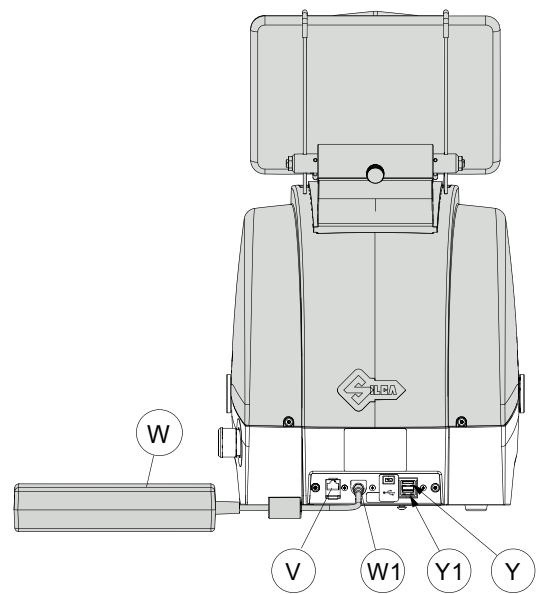

Fig. 6

1.2 SAFETY

FUTURA PRO ONE is entirely built in compliance to the Machine Directives. The operations for which it has been designed are easily carried out with no risk to the operator.

The adoption of general safety precautions and observation of the instructions provided by the manufacturer in this manual eliminate all human error, unless deliberate.

FUTURA PRO ONE is designed with features which make it completely safe.

- **Safety shield**

The protective shield is designed to cover the working parts as completely as possible, ensuring operator safety.

The shield (C) must be raised in order to fit keys for cutting or carry out other operations (Fig. 7).

Raising the shield by means of a microswitch will deactivate the operating and movement functions, including the cutter, and failed shield closing will be notified with a special message on the tablet.

To re-activate the work cycle, lower the shield and follow the instructions on the tablet.

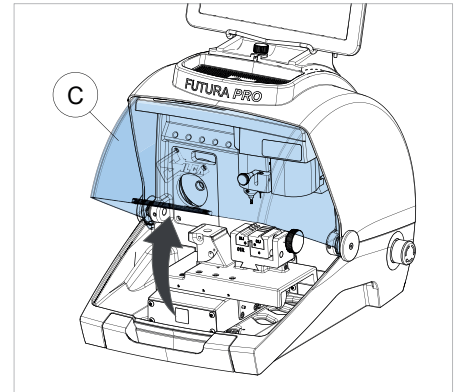

Fig. 7

- **Emergency stop**

Use the red emergency button (R) (Fig. 5), located on the right-hand side of the machine to stop the machine immediately in the event of serious malfunctioning or a hazard for the operator.

When the cause of the emergency has been eliminated, turn the button 45° clockwise to deactivate it.







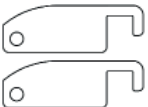

NOTE: the operator is responsible for keeping the area around the button clear so that it can be reached as quickly as possible.

1.3 TECHNICAL DATA



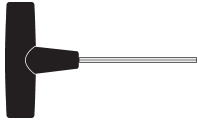

Electricity supply:	Machine: 24V d.c.- 5,5 Amp. - 130W Power pack: 90/264V a.c. - 50/60Hz - 220W MEANWELL GS220A24-R7B
Cutter motor:	24V d.c.
FUTURA PRO ONE	
Cutter (Dimple cuts):	01D in HSS Super Rapid steel
Cutter (Track cuts):	01LW carbide, coated
FUTURA PRO ONE ABUS®	
Cutter (Dimple cuts):	01D and 07D in HSS Super Rapid steel
Cutter (Track cuts):	03L in HSS Super Rapid steel, coated
Tool speed:	12100 rpm
Movement:	on 3 axes (with special bushes) driven by step motors (on rectified roller guides)
FUTURA PRO ONE	
Clamp 01R (for Dimple/Track cuts)	removable and provided with interchangeable jaws: 01J - 02J
FUTURA PRO ONE ABUS®	
Clamp 01R (for Dimple/Track cuts)	removable and provided with interchangeable jaws: 01J - 02J 05J - 06J 29J - 30J
Runs:	X axis: 30 mm Y axis: 50 mm Z axis: 27 mm
Dimensions:	width: 318 mm depth: 413 mm height with tablet and stand: 522 mm (340 mm without tablet and stand)
Mass:	Kg. 17
Noise level:	sound pressure Lp(A) = - brass dimple keys: 70.0 dB(A) - brass track keys: 74.0 dB(A) - steel track keys: 75.0 dB(A)

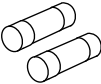
1.4 ACCESSORIES PROVIDED

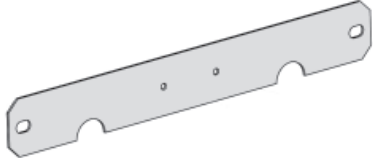
FUTURAPRO ONE and FUTURAPRO ONE ABUS® come with a set of accessories for operation and maintenance (tools, hex wrenches...) supplied in a special tool kit comprising:

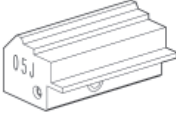
FUTURA PRO ONE - FUTURA PRO ONE ABUS®		
stop bar 	cutter 01D 	Allen keys set 1,5 ÷ 5 mm 
stylus touch pen 	tracer point 02T 	"T" allen key 2,5 mm 
universal adapter 	fresa 01LW (only Futura PRO ONE) 	USB pen (FAT32 format) 
slanted brush 	fuses 4 Amp.- delayed 	

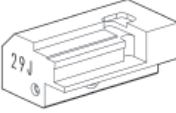
Cutters and tracers on machine:	Separately:
tracer point 01T 	fixing bracket 

FUTURA PRO ONE ABUS®: additional accessories provided		
cutter 07D 	05J jaw 	06J jaw 
cutter 03L 	29J jaw 	30J jaw 

2 HANDLING

The FUTURA PRO ONE key-cutting machine is easy to handle and there are no special hazards involved in moving it.

The packed machine can be carried manually by one person.

2.1 PACKING

The packing for the FUTURA PRO ONE key-cutting machine ensures safe handling of the machine and all its components.

Packing comprises expanded plastic material wrapped around the machine.

The robust cardboard box in which it is placed and the nylon wrapping protect the machine even when stored for a long period.

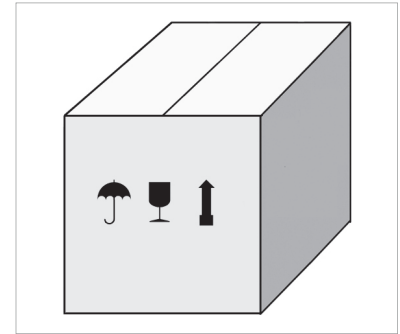

Fig. 8



Keep dry



Handle with care



Up

The symbols on the outside of the cardboard box give indications for transport.



ATTENTION: keep the complete packing for future machine transfers.

2.2 UNPACKING

To remove the machine from its packing:

- 1) Cut the strapping with scissors and remove.
- 2) Open the box carefully without damaging it.
- 3) Free the machine from the protective shells.
- 4) Check the contents of the packing, comprised of:
 - FUTURA PRO ONE key-cutting machine
 - documentation comprising: user's manual, spare parts sheet, specialist guide and warranty
 - tablet
 - tablet stand
 - power lead
 - power pack
 - tool kit
 - fixing bracket

2.3 HANDLING THE MACHINE

Once removed from its packing place FUTURA PRO ONE directly on the work bench; one person can easily perform this operation.



ATTENTION: lift the machine by holding onto the base. Never lift the machine by gripping the clamps, levers or other parts.

3 MACHINE INSTALLATION AND PREPARATION

Installation is the customer's task and does not require any special skills.

The key-cutting machine is supplied ready for use and does not need calibration except for the tools to be used and any additional jaws that are included with the machine; however, the operator is required to make certain checks and prepare the machine for use.

NOTE: the machine is shipped with a steel rod installed in the cutter shaft to prevent the allen screw from backing out during transit. REMOVE THE ROD AND INSTALL THE PROPER CUTTER PRIOR TO ATTEMPTING TO CUT A KEY!

3.1 CHECKING FOR DAMAGE

FUTURA PRO ONE is a solid compact machine and will not break if handling, unpacking and installation are carried out to the instructions in this manual. However, it is good practice to check that the machine has not been damaged.

3.2 ENVIRONMENTAL CONDITIONS

To make the most of the key-cutting machine, bear in mind the following environmental parameters: it is advisable for the area to be dry with good air circulation.

The optimum environmental conditions for machine operation are:

- temperature 10° C to 40°C;
- relative humidity: approx 60%.

3.3 POSITIONING

- 1) Place the key-cutting machine on a solid horizontal work bench suitable for the weight of the machine (17 Kg). The work bench should be approximately 100-120 cm high to facilitate access to the working parts. We recommend leaving at least 30 cm clearance behind and around the machine to ensure good ventilation and facilitate handling (Fig. 9).
- 2) Make sure machine voltage is suitable for the mains supply and that the latter is earthed with a differential switch.
- 3) Connect the power lead (power pack) to the machine (chap.3.4.2).

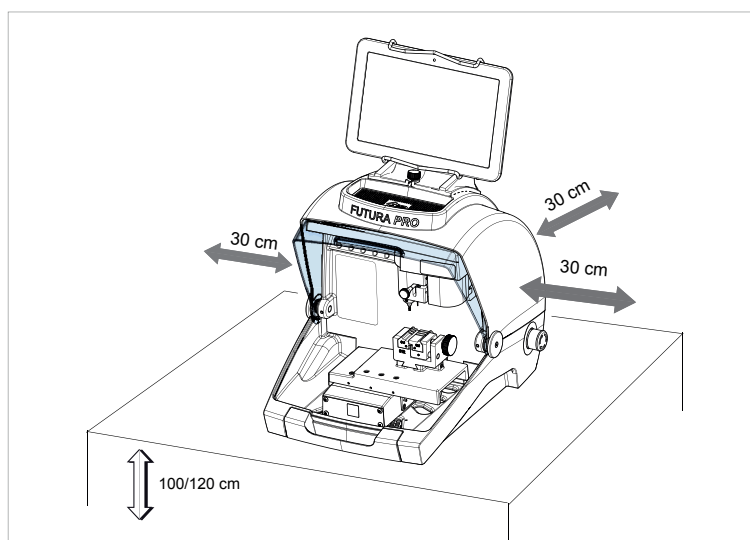

Fig. 9

3.4 SEPARATE PARTS

The machine packing also contains the following components, separately packed:

3.4.1 Tablet stand and tablet

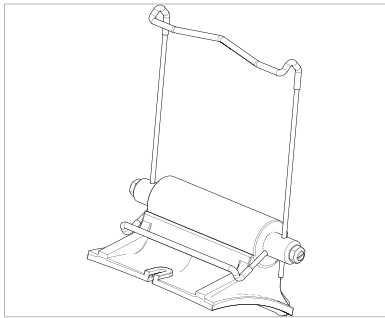

Fig. 10

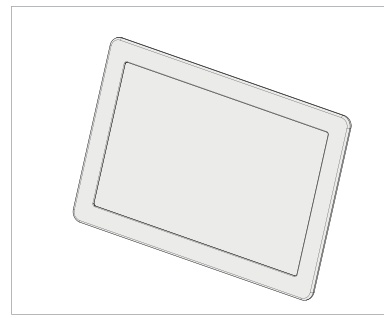

Fig. 11

These items are separate from the machine and must be unpacked and installed by the operator in the way described below:

- 1) Remove the 2 items from their packing.
- 2) Loosen the knob on top of the machine cover (Fig. 12).
- 3) Install the tablet stand so that the special profile fits into the slot on the machine cover (Fig. 13).
- 4) Screw down and tighten the knob to secure the tablet stand to the cover (Fig. 14).
- 5) Fit the tablet into its stand (Fig. 15).

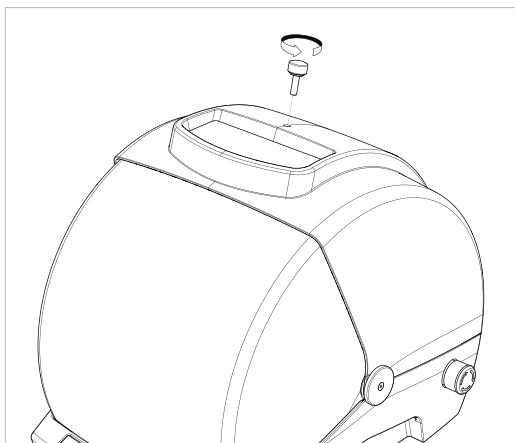

Fig. 12

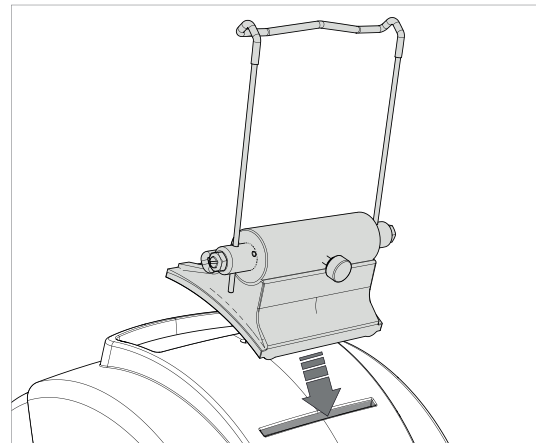

Fig. 13

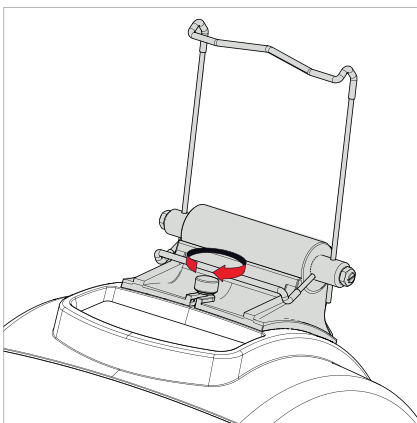

Fig. 14

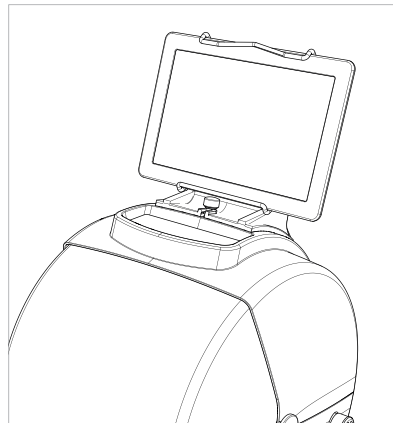

Fig. 15

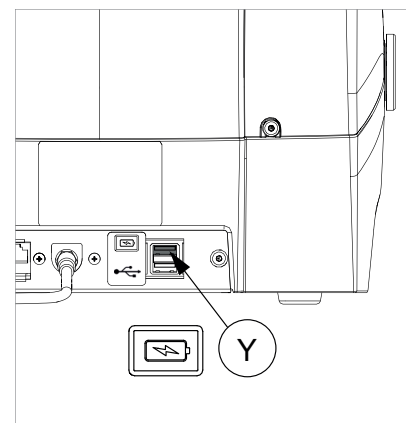

Fig. 16

- 6) Connect the tablet USB/Micro USB cable to the USB tablet port (Y) located on the back of Futura PRO ONE.

3.4.2 Power pack and lead

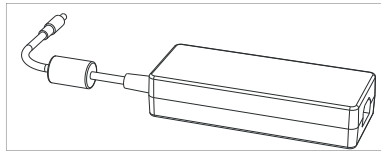

Fig. 17

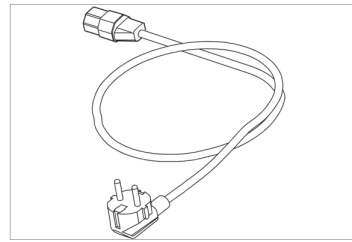

Fig. 18

Connect FUTURA PRO ONE to the power pack (W) and connect the latter to the power supply with the power lead (W2).

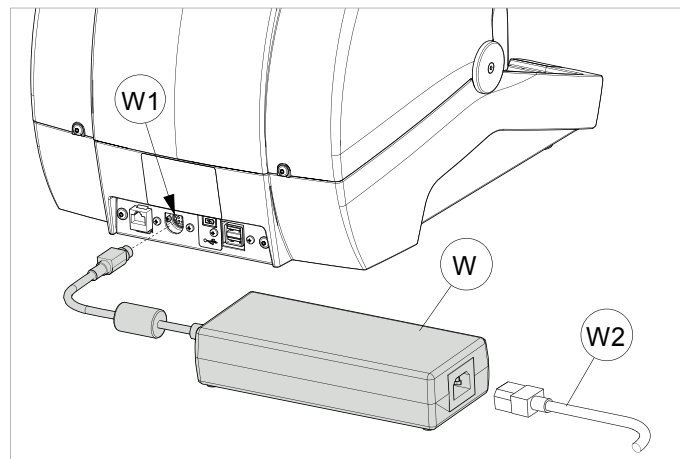

Fig. 19

3.4.3 Fixing bracket

If the key-cutting machine is transported and used on a vehicle, e.g. a van, it must be prepared as follows:

- 1) Turn off the machine and detach the power lead.
- 2) Remove the tablet holder and tablet.
- 3) Turn the key-cutting machine onto its back.
- 4) Connect the fixing bracket to the machine and secure with the 2 screws.
- 5) Return the machine to its upright position on the work top.

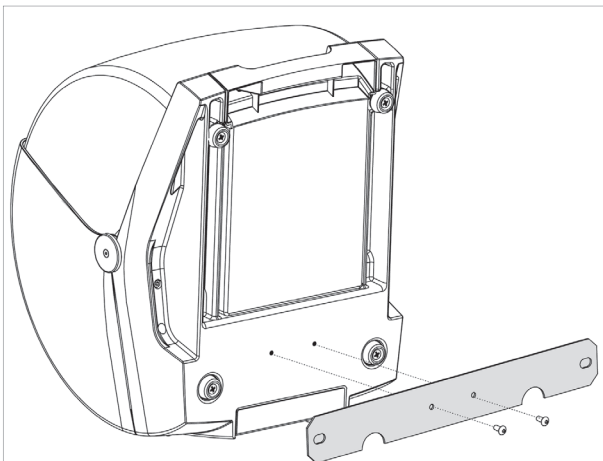

Fig. 20

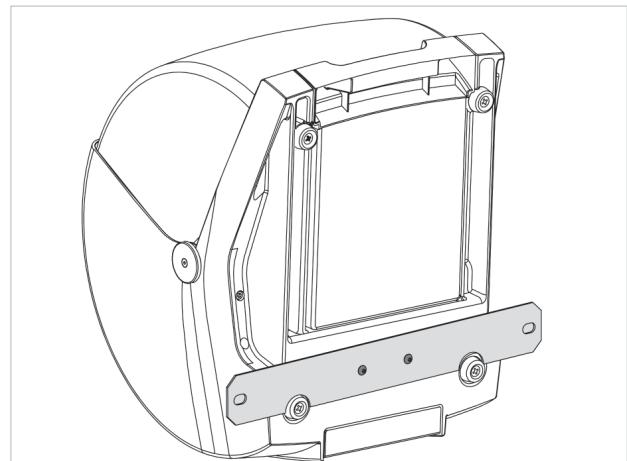

Fig. 21

3.5 WORK STATION DESCRIPTION

One operator is enough to operate the machine, which has the following operating parts:

- **General ON/OFF/emergency button (R) located on the right-hand side of the machine**
- **Key holding clamp (P)**
- **Tablet (B)**
- **Tablet ON button (B1)**
- **Safety shield (C)**
- **Cutter (G)**

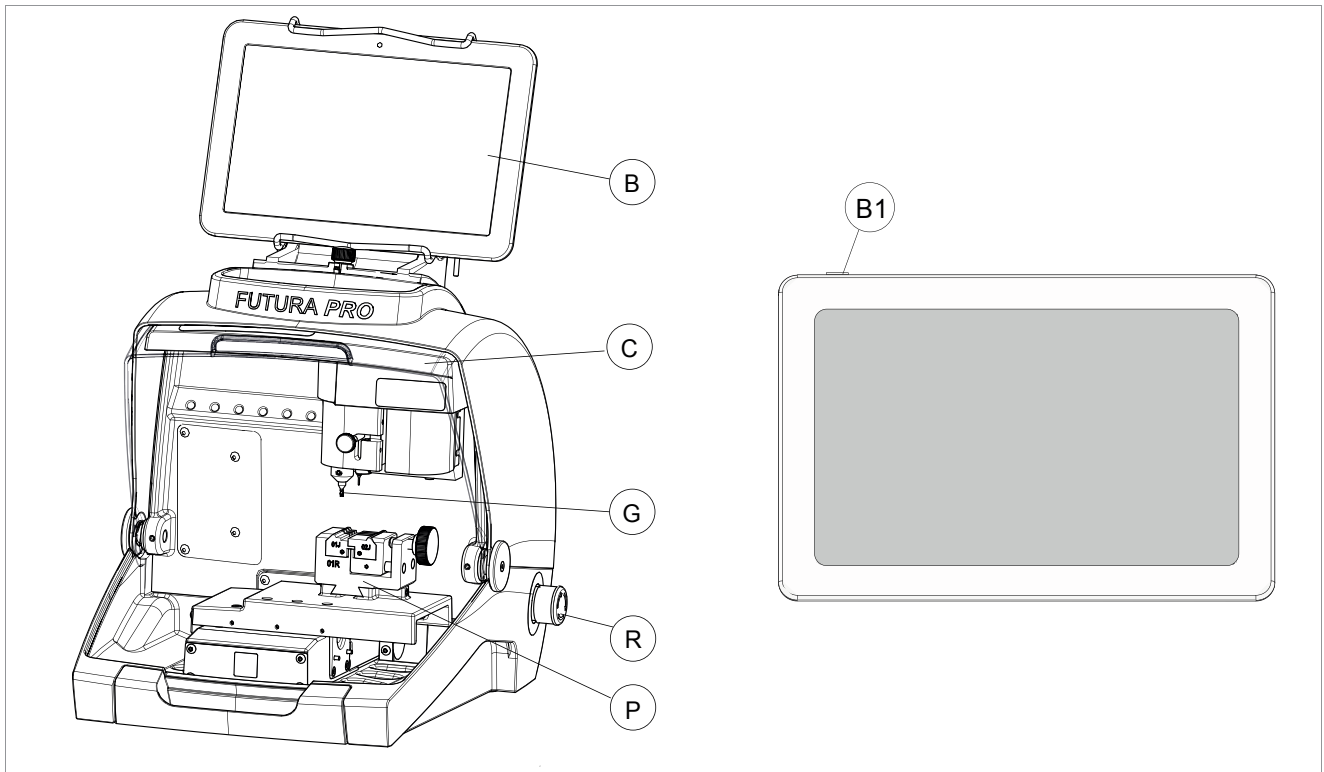

Fig. 22

MACHINE POWER ON

Rotate the red button (R) to turn on the machine.

4 TABLET REGULATION AND USE

- 1) Connect the tablet to a power source by means of its power pack in order to charge it (3 hours for the first charge). The tablet can also be charged connected to the specific USB port (Y) on the back of the machine (Fig. 16, page 12).
- 2) Turn on the tablet by holding down the push button (B1) (Fig. 22) holding it down for a few seconds.

REGULATING TABLET INCLINATION

- 1) Loosen the knob (B2).
- 2) Incline the stand as required.
- 3) Tighten the knob (B2).

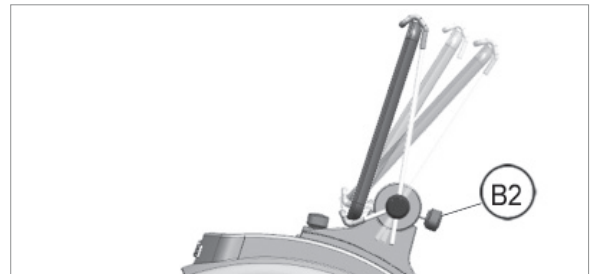
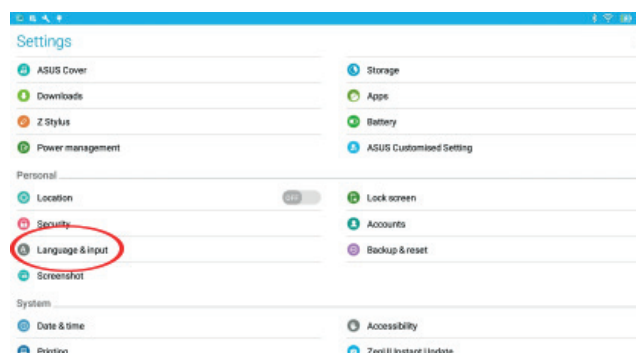

Fig. 23

4.1 CHOICE OF LANGUAGE



- 1) Select "Settings".



- 2) Scroll up with your finger.
- 3) Select Language & Input and then Language (on the right).
- 4) Scroll and select the desired language (i.e. English United States).
- 5) Select Silca Keyboard (if desired)
- 6) Select Display > Sleep > Never. This will prevent the application from timing out and closing the session.
- 7) To quit:

- For all software functionalities on board the Silca key-cutting machine, see the **SOFTWARE OPERATING GUIDE on your tablet (Ch.10)**.
- Further instructions are given in the quick guide for the tablet.

5 CLAMP FOR DIMPLE AND TRACK KEYS - 01R

According to the type of key to be decoded and/or cut, follow the instructions in the Silca tablet program regarding:

- clamp
- use of jaws (Q1) and (Q2)
- clamp stop (Fig. 25 and Fig. 26)

5.1 FITTING THE KEY

The clamp is designed to house high security keys with shoulder stop or tip reference.

For shoulder stop keys, place the shoulder of the key against the jaws (stop "0") (Fig. 25) and the others (tip stop) must be placed against one of the grooves (1-2-3-4), as indicated in the Silca tablet program. For this operation use the bar provided (Fig. 26).

NOTE: the stop bar must be removed before decoding or cutting.

- 1) Fit the key to be cut into its seat and ensure it is resting firmly on the clamp plate.
- 2) Tighten the knob (M) to secure the key.

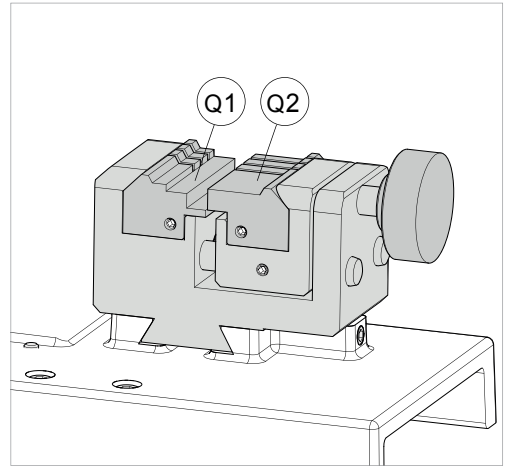

Fig. 24

5.1.1 DIMPLE keys

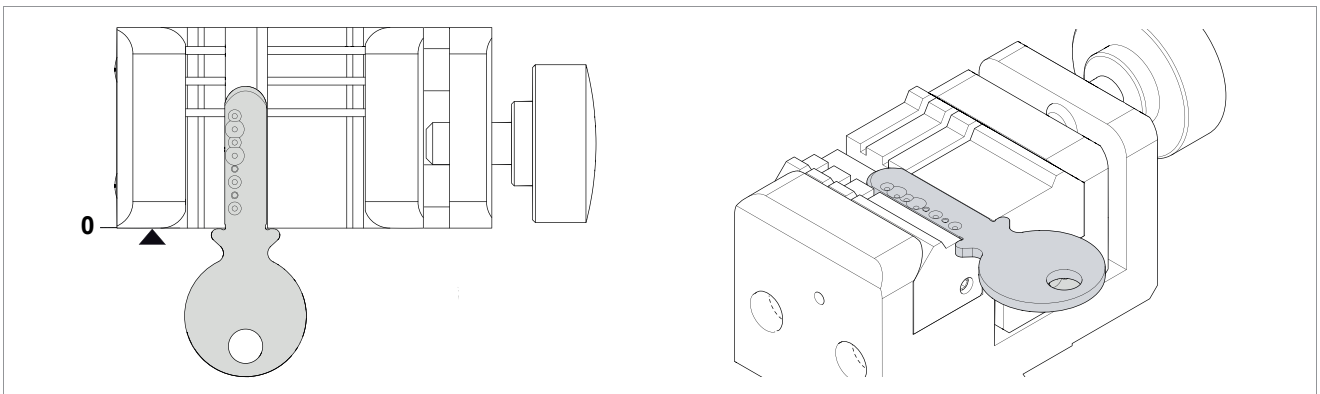

Fig. 25 - SHOULDER STOP

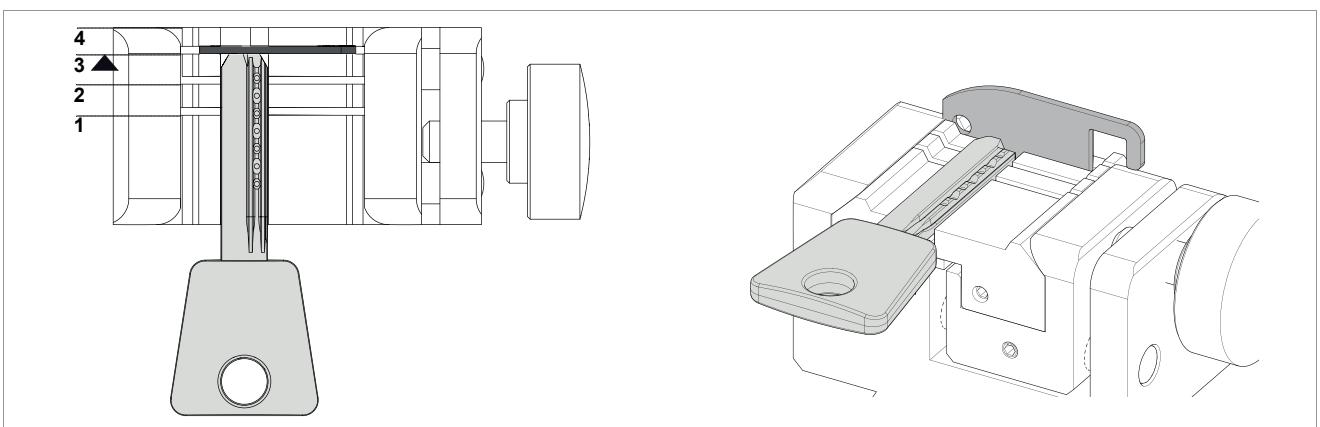

Fig. 26 - TIP STOP

5.1.2 TRACK type keys

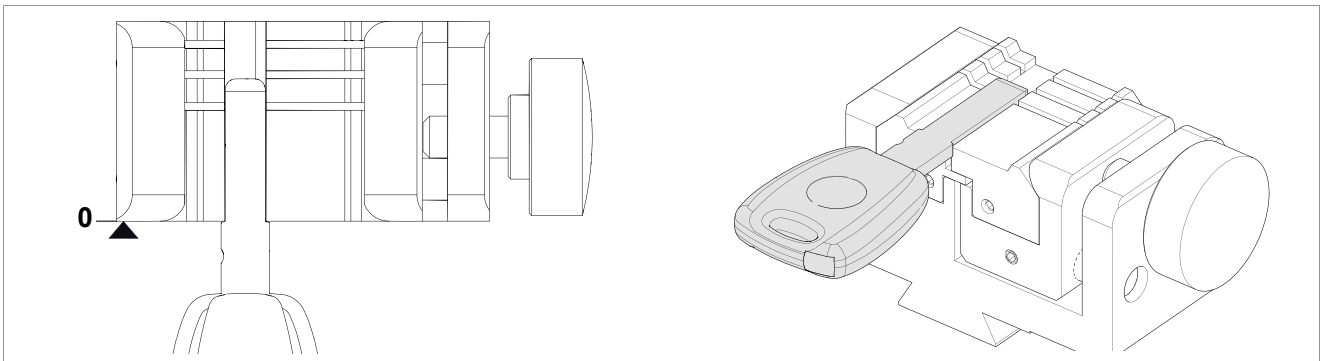

Fig. 27 - SHOULDER STOP

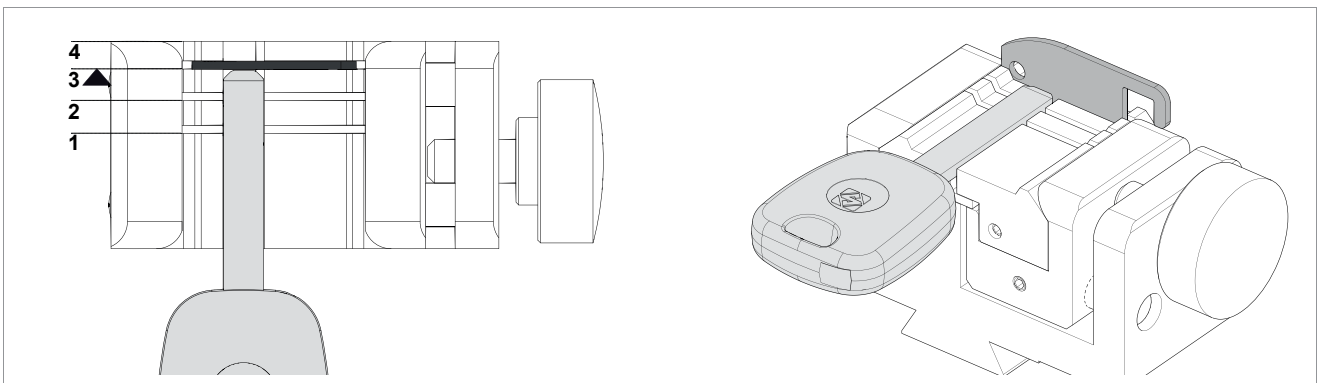

Fig. 28 - TIP STOP

5.2 REMOVING / FITTING CLAMP 01R

- 1) Raise the safety shield.
- 2) Loosen the grub screw (P2) and remove the clamp by pulling it towards the operator.
- 3) Carefully clean the clamp support seat.
- 4) Clean the clamp before fitting into the support.
- 5) Fit the clamp (with knob on the right) into the special dovetail and take up against the stop pin.
- 6) Tighten the grub screw (P2) to secure the clamp.

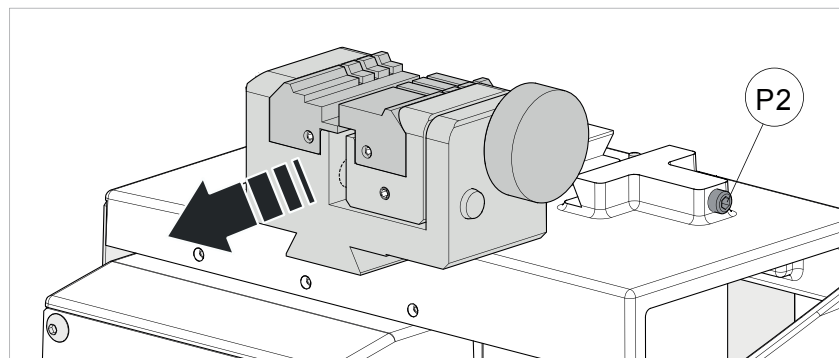

Fig. 29

5.3 REMOVING/FITTING THE JAWS ON CLAMP 01R

- 1) Raise the safety shield.
- 2) Loosen the knob (P1) by a couple of turns (Fig. 30).
- 3) Use your fingers to pull the jaw to be removed out towards the operator (Fig. 31).
- 4) Carefully clean the seat of the jaw on the clamp.
- 5) Clean the jaw before fitting into the clamp.
- 6) Fit the jaw up against the stop pin.

NOTE: there is only one way to fit the jaw into the clamp.

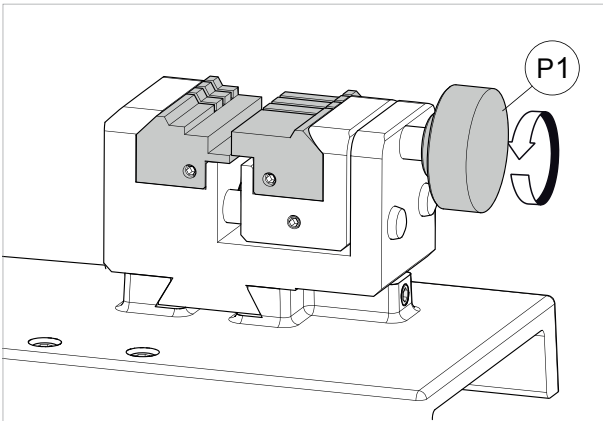

Fig. 30

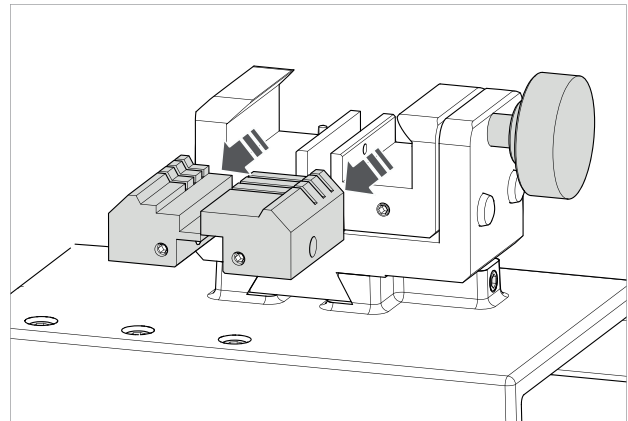

Fig. 31

5.4 USING TRACER 01T

The tracer 01T is used to read/decode both dimple and track keys. This tracer may or may not be required according to the type of key to be decoded and the dimensions involved.

ATTENTION: Anodised aluminium keys, plastic keys or any other key without electrical conductivity CANNOT BE decoded!

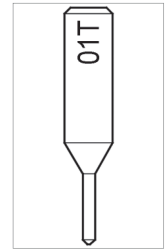

Fig. 32

- **ACTIVATING THE TRACER 01T (Fig. 33)**
 - To use the tracer: move the lever (J1) to the left and lower the tracer.
 - When the tracer is lowered, turn the lever knob clockwise.
- **EXCLUDING THE TRACER 01T (Fig. 34)**
 - Turn the lever knob anticlockwise.
 - Take the tracer to the idle position: raise the lever (J1) and move to the right.

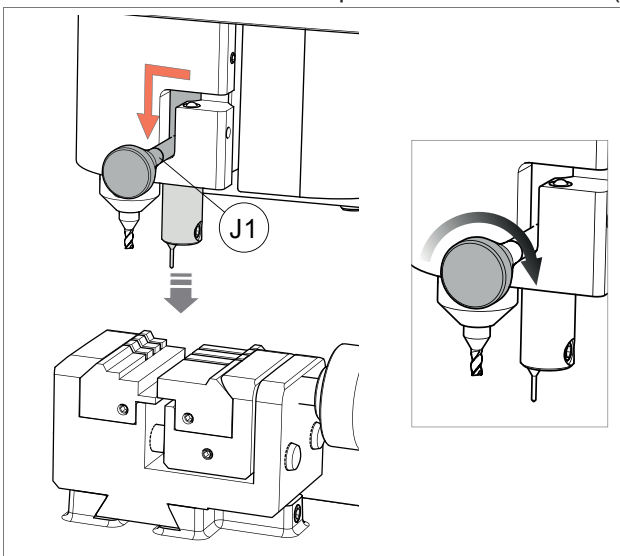

Fig. 33

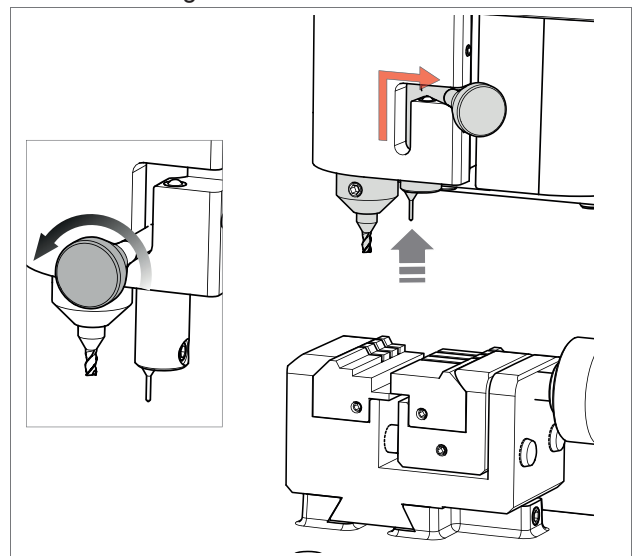

Fig. 34

5.5 TRACER 02T

Some applications may require the use of the 02T tracer. The 02T tracer (when required) should be placed into the cutter shaft (replacing the cutter) (Fig. 36).

Note: fit the new tracer pushing all the way upwards.

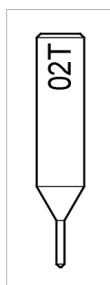

Fig. 35

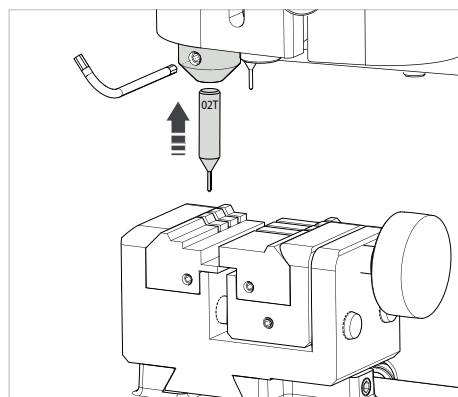

Fig. 36

NOTE: for cutting and/or decoding operations with the tracer point 02T, the tracer 01T must be in the idle position (Fig. 34). REPLACE THE 02T TRACER WITH THE REQUIRED CUTTER PRIOR TO ATTEMPTING TO CUT A KEY.

5.6 ENGRAVING

ATTENTION: this function is not available for FUTURA PRO ONE ABUS.

The ENGRAVING function requires the following accessories:

- Jaw 01E (code D747837ZB)
- Jaw 02E (code D748739ZB)
- Adapter for plane 4 (code D750763ZB)
- Cutter 18DW specific for engraving (code D748741ZB)

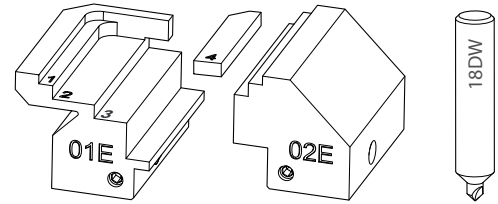

Fig. 37

- Insert jaws 01E and 02E into the 01R clamp and gauge.
- Open jaws 01E and 02E and fit the key head or medal to be engraved (further details in the SOFTWARE Operating Guide or online HELP desk).

ATTENTION: objects MUST BE METAL, NOT STAINLESS STEEL. Materials such as wood, paper, plastic and ceramics cannot be engraved. Make sure the surface of the object to be engraved is flat.

The jaw/adaptor kit runs 4 different planes/housings (Fig. 39) according to the size of the medal or key head to be engraved, and/or according to the position of the head, as shown in the Software Guide.

PLANE	WIDTH of the object to be engraved	ENGRAVING AREA (L x H)
1	min 26 - max 32 mm	32 mm x 40 mm
2	min 20 - max 26 mm	24 mm x 36,5 mm
3	min 8 - max 14 mm	12 mm x 36,5 mm
4	min 14 - max 20 mm	18 mm x 36,5 mm

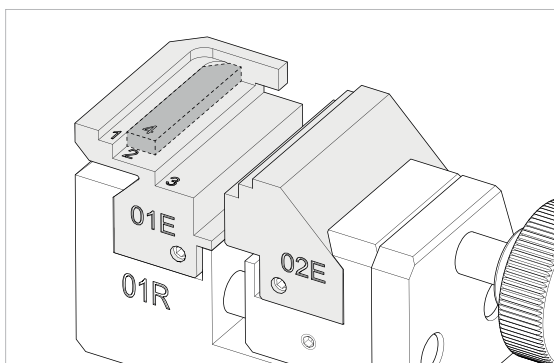

Fig. 38

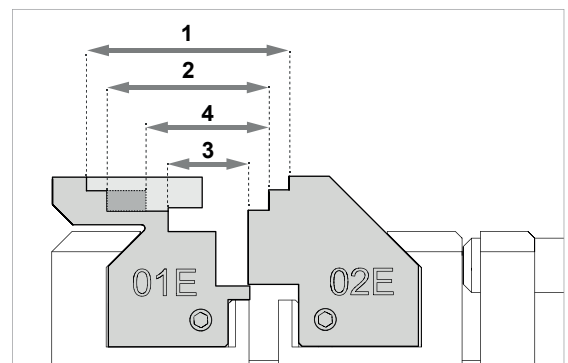

Fig. 39

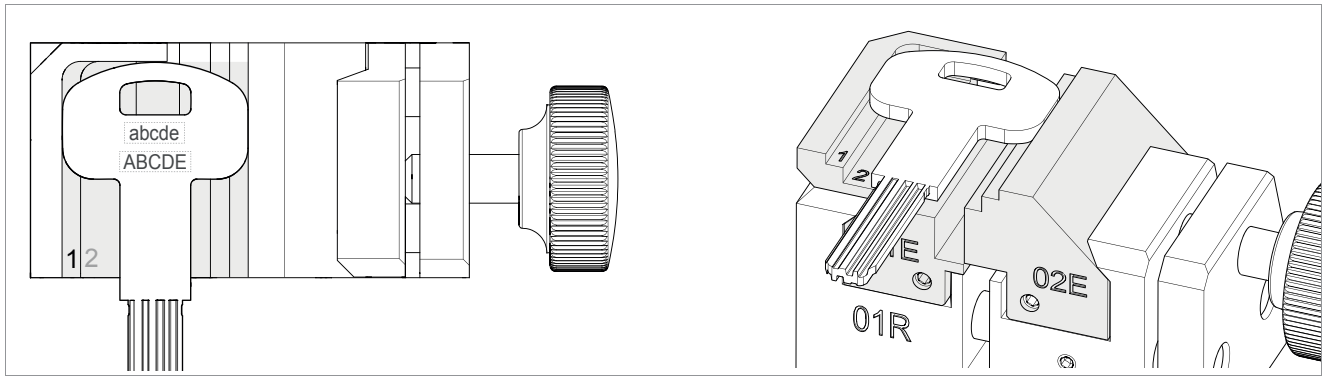

Fig. 40 - plane 1

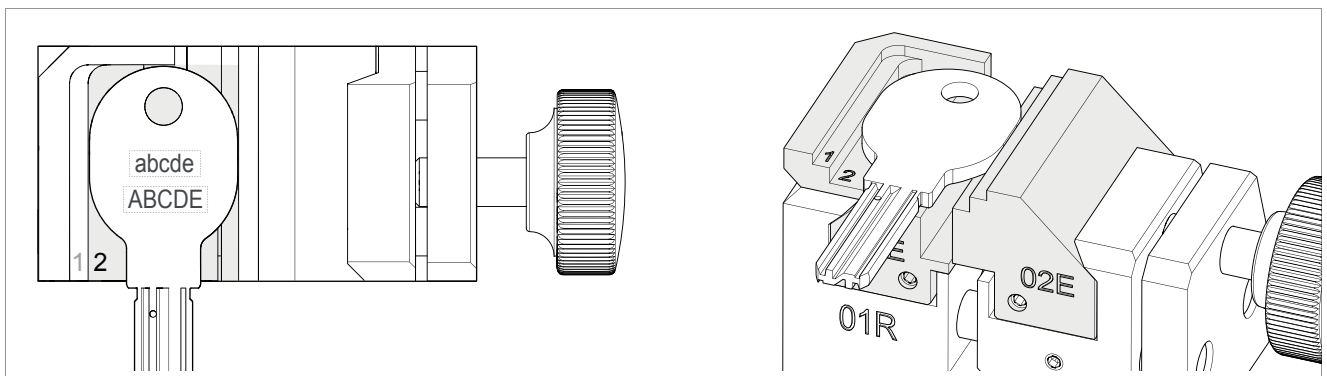

Fig. 41 - plane 2

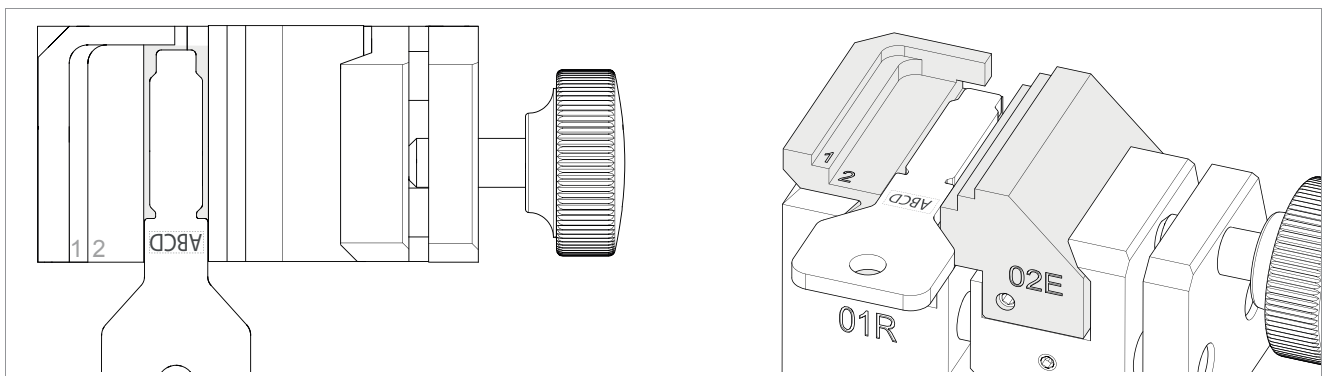

Fig. 42 - plane 3

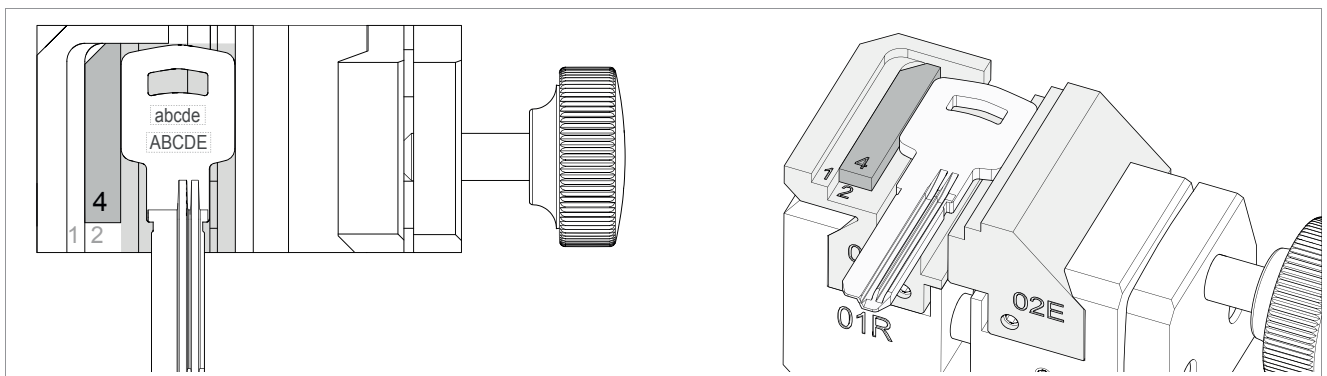

Fig. 43 - plane 4

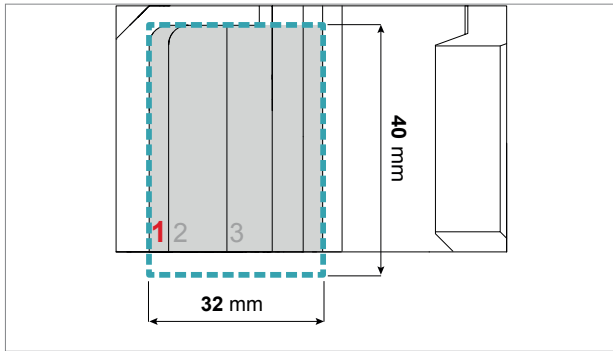

Fig. 44 - ENGRAVING AREA plane 1

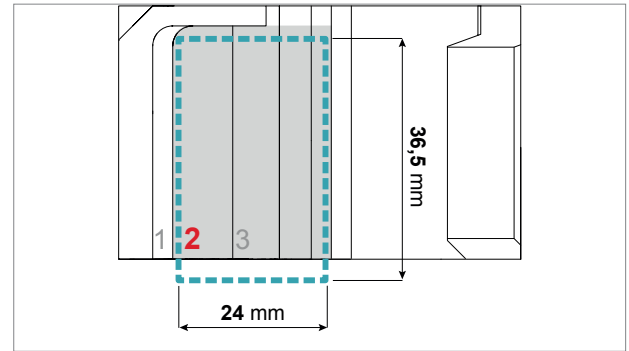

Fig. 45 - ENGRAVING AREA plane 2

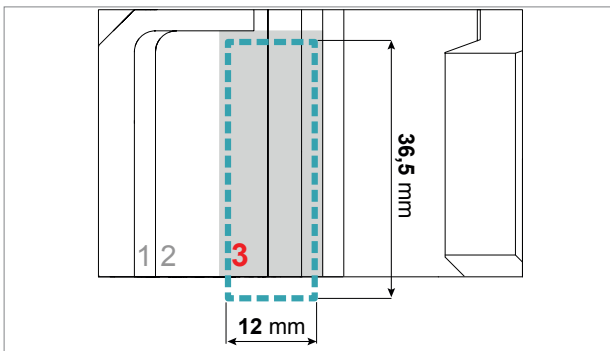

Fig. 46 - ENGRAVING AREA plane 3

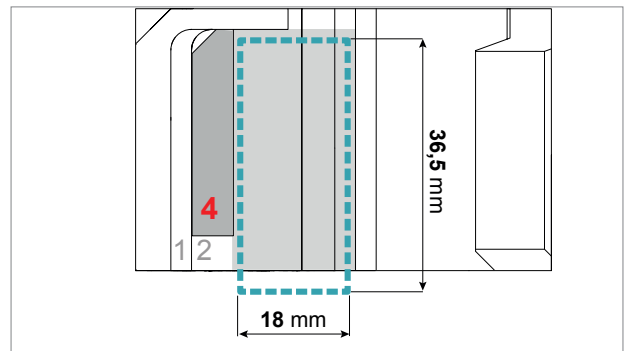

Fig. 47 - ENGRAVING AREA plane 4

Further details in the SOFTWARE Operating Guide or online HELP desk.

6 CLEANING

- **Keep the operational parts of the machine as clean as possible by brushing away the chippings in areas where they accumulate during cutting operations.**
- **Under no circumstances should compressed air be used to clear the work zone of chippings as this will blow them onto the moving parts.**
- **Never use oily products or thinners for cleaning painted surfaces, clamps, electrical or electronic connections.**
- **Make sure the key to be decoded is clean.**

7 MAINTENANCE



ATTENTION: for repairs or replacement of parts for maintenance, the 'CE' mark is guaranteed only if original spare parts provided by the manufacturer are used.

The FUTURA PRO ONE key-cutting machine does not need special maintenance, but it is good practice to check and if necessary replace parts subject to wear: cutter, tracer point, belt.

Replacement operations are simple and can be performed by the operator.



ATTENTION: DO NOT USE COMPRESSED AIR!



ATTENTION: to maintain machine efficiency we recommend using protective oil such as WD40 or similar to apply to the burnished mechanical parts. Make sure the oil does not come into contact with the electronic parts.

Before performing any type of maintenance (checks or replacements) read the warnings below:

- Do not perform any maintenance operations with the machine on.
- Always disconnect the power lead.
- Follow the instructions in the manual carefully.
- Use original spare parts (see provided spare parts sheet).

7.1 OPERATIONS

- Access to rear compartment
- Cylindrical cutter and/or tracer point replacement
- Tracer 01T replacement
- Checking and replacing fuse
- Battery replacement

7.2 ACCESS TO REAR COMPARTMENT

- 1) Turn off the key-cutting machine and disconnect the power lead.
- 2) Remove the tablet.
- 3) Loosen the 2 screws (E1) and the 2 screws (E2).
- 4) Rotate the cover towards the front of the machine.

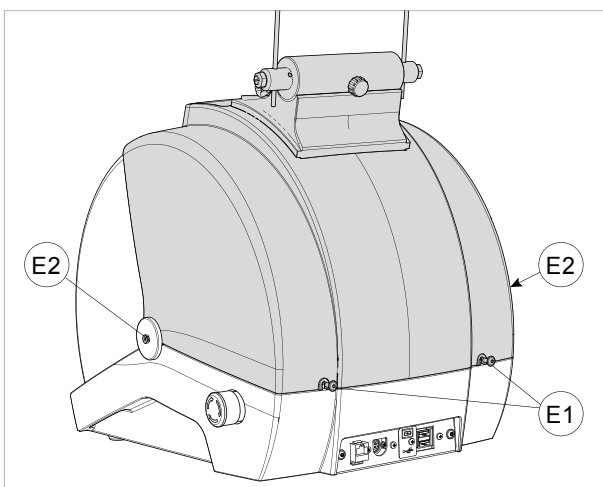

Fig. 48

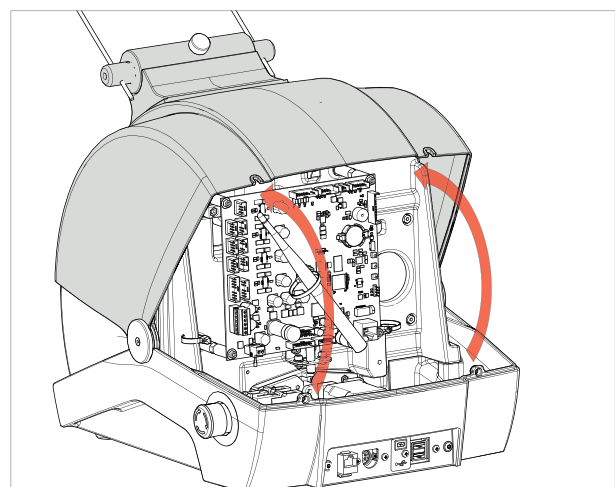

Fig. 49

7.3 CUTTER AND/OR TRACER POINT REPLACEMENT

- 1) Raise the safety shield.
- 2) Rotate the cutter shaft (G1) by hand and take the grub screw (G2) to the front of the machine.
- 3) Use a hex key to loosen the grub screw (G2) and remove the tool.
- 4) Fit the new tool, pushing all the way upwards.
- 5) Tighten the grub screw (G2) to secure the tool.

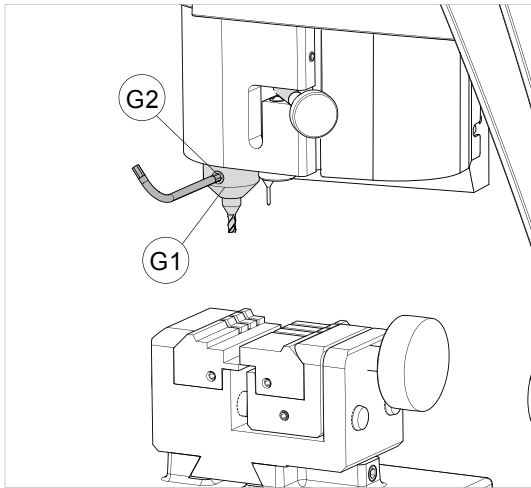

Fig. 50

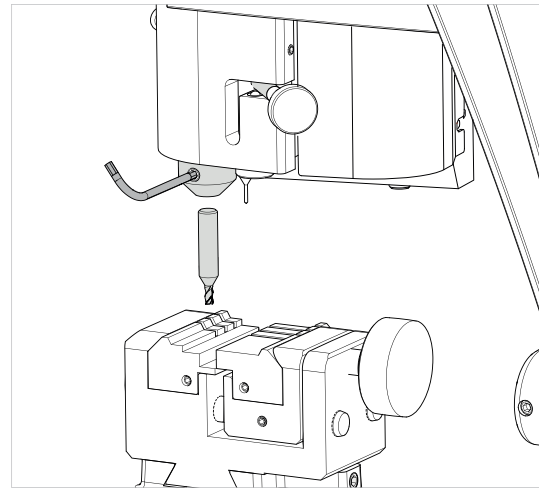

Fig. 51

NOTE: the machine is shipped with a steel rod installed in the cutter shaft to prevent the allen screw from backing out during transit. REMOVE THE ROD AND INSTALL THE PROPER CUTTER PRIOR TO ATTEMPTING TO CUT A KEY!

7.4 TRACER 01T REPLACEMENT

- 1) Raise the safety shield.
- 2) Move the lever (J1) to the left to lower the tracer.
- 3) Use a hex key to loosen the grub screw (J2) and remove the tracer.
- 4) Fit the new tracer, pushing all the way upwards.
- 5) Tighten the grub screw (J2) to secure the tracer.

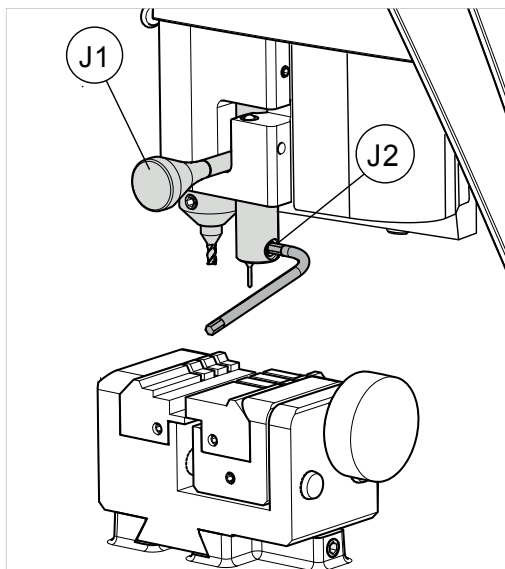

Fig. 52

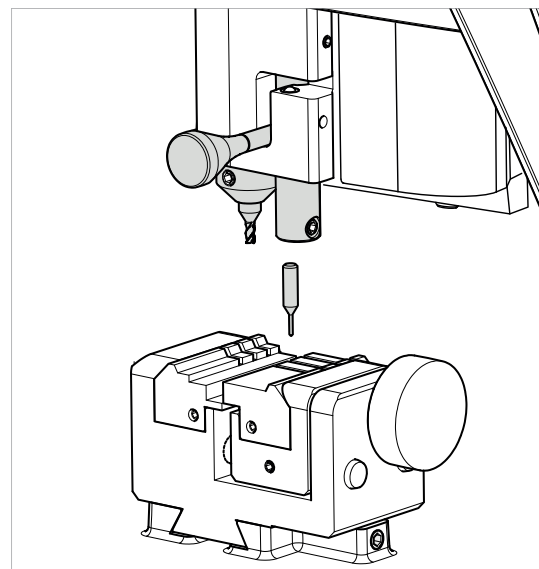

Fig. 53

7.5 CHECKING AND REPLACING FUSE

Fuses should be checked with a tester (ohmmeter, multimeter, etc.) as they may appear to be in good condition even when they are electrically faulty. Fuses must always be replaced with the same amperage and type (rapid or delayed), as indicated in this manual.

FUTURA PRO ONE has 1 fuse:

4 Amps delayed

Protects the cutter motor and their electronic controls (24V d.c.)

To check and/or replace the fuse proceed as follows.

- 1) Turn the machine off and unplug it from its power supply cable.
- 2) Access the rear compartment (chap.7.2).
- 3) Remove the fuse from its seat (Fig. 54) and replace if necessary.

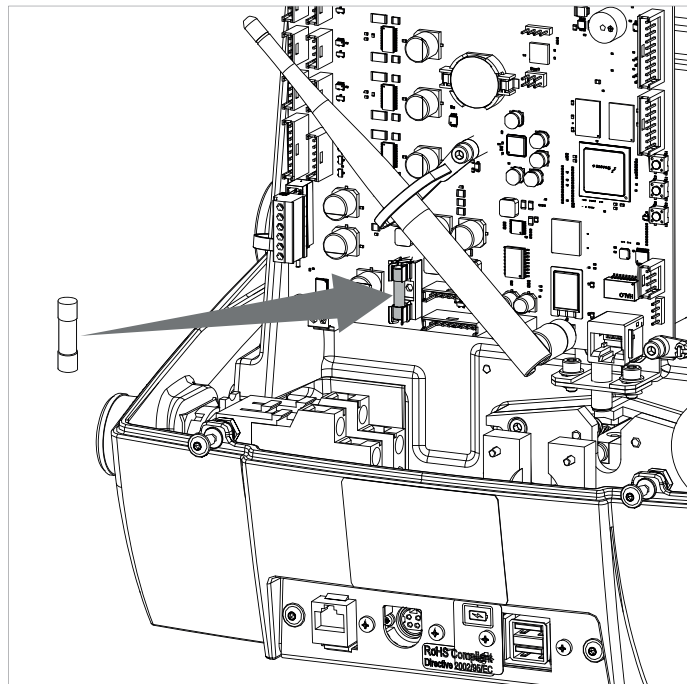

Fig. 54

7.6 BATTERY REPLACEMENT



ATTENTION: only specialised personnel can change the battery.

- 1) Turn the machine off and unplug it from its power supply cable.
- 2) Access the rear compartment (chap.7.2).
- 3) Use insulated screwdriver to remove the flat battery.
- 4) Insert the new battery into its seat, paying attention to the poles.



ATTENTION: use the same type of lithium battery CR2032 3 Volt.

DANGER OF EXPLOSION IF THE BATTERY IS REPLACED WITH ONE OF THE WRONG TYPE.

- 5) Follow the instructions in Ch.8 DISPOSAL to dispose of spent batteries.

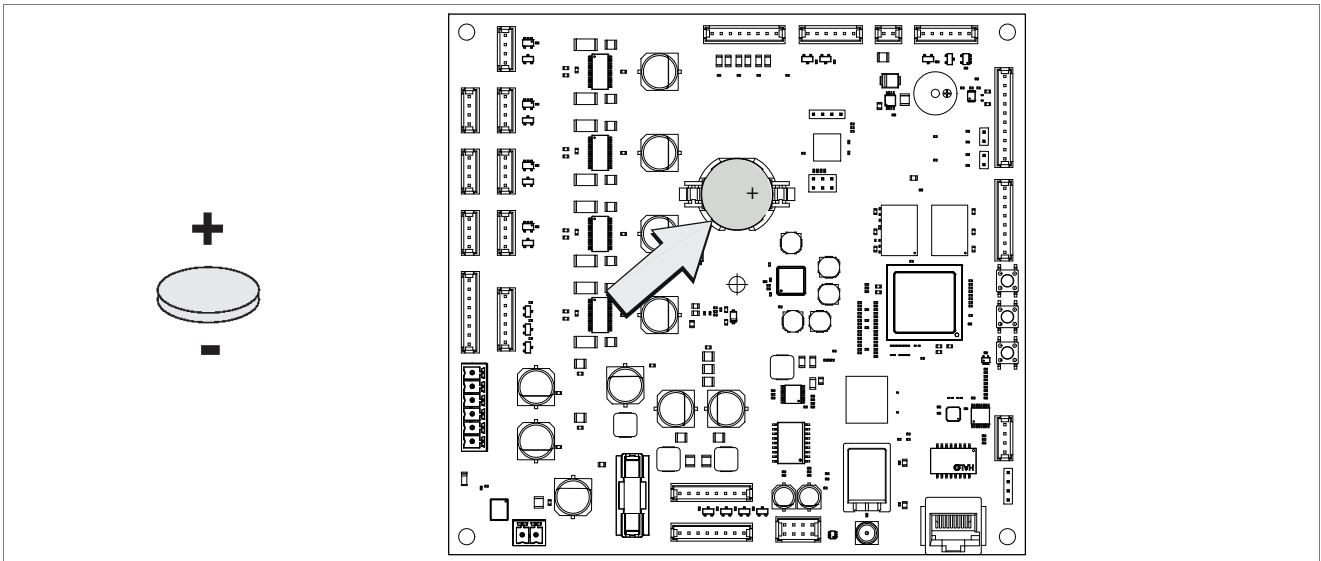

Fig. 55

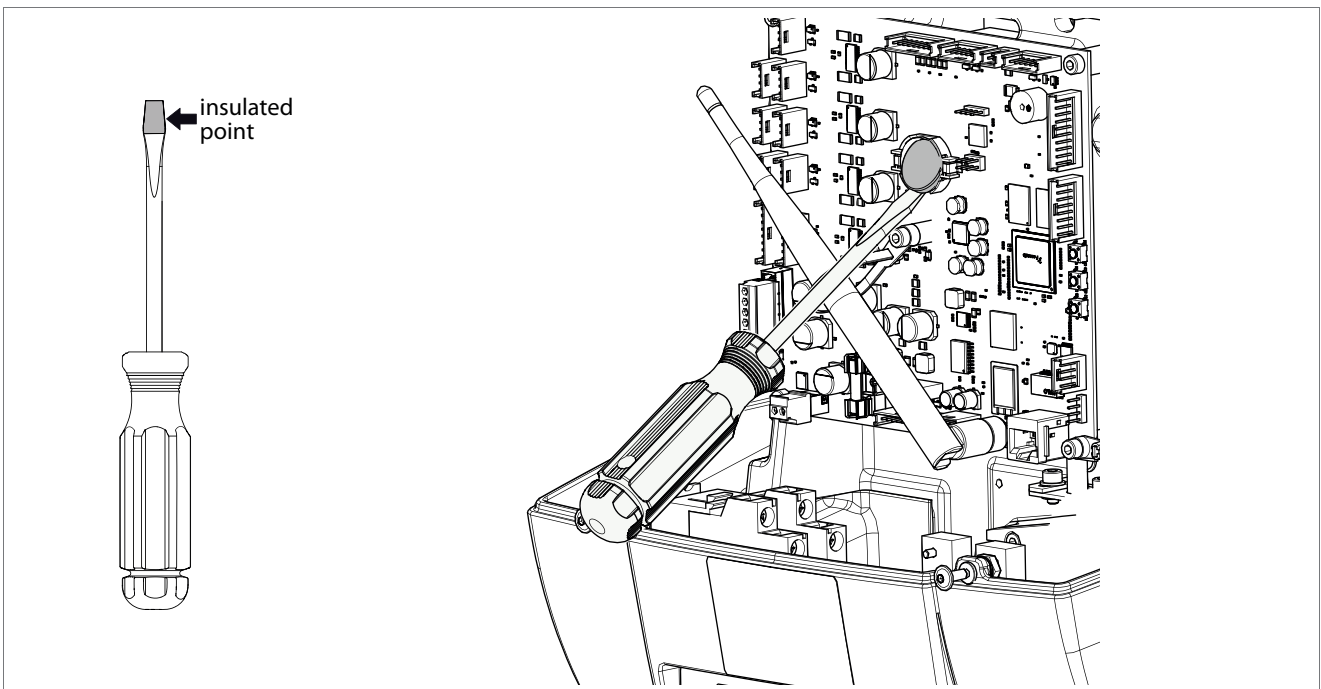

Fig. 56

8 DISPOSAL

For correct disposal please refer to current standards.

INFORMATION FOR USERS OF PROFESSIONAL EQUIPMENT



From “Actuation of Directive 2012/19/EU regarding Waste Electrical and Electronic Equipment (WEEE)”

The symbol of a crossed waste bin found on equipment or its packing indicates that at the end of the product's useful life it must be collected separately from other waste so that it can be properly treated and recycled.

In particular, separate collection of this professional equipment when no longer in use is organised and managed:

- a) directly by the user when the equipment was placed on the market before 31 December 2010 and the user personally decides to eliminate it without replacing it with new equivalent equipment designed for the same use;
- b) by the manufacturer, that is to say the subject which was the first to introduce and market new equipment that replaces previous equipment, when the user decides to eliminate equipment placed on the market before 31 December 2010 at the end of its useful life and replace it with an equivalent product designed for the same use. In this latter case the user may ask the manufacturer to collect the existing equipment;
- c) by the manufacturer, that is to say the subject which was the first to introduce and market new equipment that replaces previous equipment, if it was placed on the market after 31 December 2010;

With reference to portable batteries/accumulators, when such products are no longer in use the user shall take them to suitable authorised waste treatment facilities.

Suitable separate collection for the purpose of forwarding discarded equipment and batteries/accumulators for recycling, treatment or disposal in an environmentally friendly way helps to avoid possible negative effects on the environment and human health and encourages re-use and/or recycling of the materials making up the equipment.

To remove batteries/accumulators, consult the manufacturer's specific instructions: (see relevant chapter in the users' manual)

The sanctions currently provided for by law shall apply to users who dispose of equipment, batteries and accumulators in unauthorised ways.

9 ASSISTANCE

Silca provides full assistance to purchasers of the key-cutting machine. To ensure complete safety for the operator, any job not specified in this manual should be carried out by the manufacturer or in the special Service Centres recommended by Silca.

At the end of the manual there is a list of authorized Service Centre addresses; if the manual was downloaded is necessary visit the website to see the contacts (www.silca.biz).

9.1 HOW TO REQUEST SERVICE

The guarantee attached to the key-cutting machines ensures free repairs or replacements of faulty parts within 24 months of purchase. All other service calls must be arranged by the customer with Silca or with a Silca service center.

10 SOFTWARE OPERATING GUIDE

The FUTURA PRO SOFTWARE OPERATING GUIDE is on the Tablet.

Go to the “Options” > “Info” menu and tap on the appropriate icon (Fig. 57).

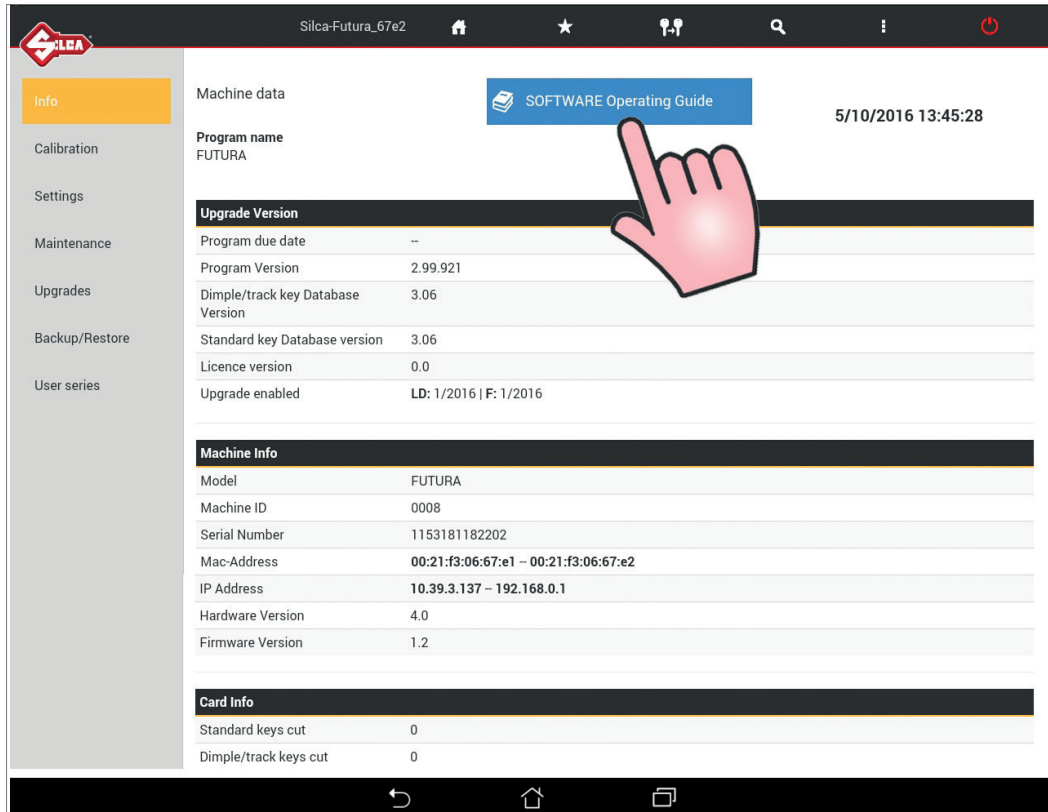
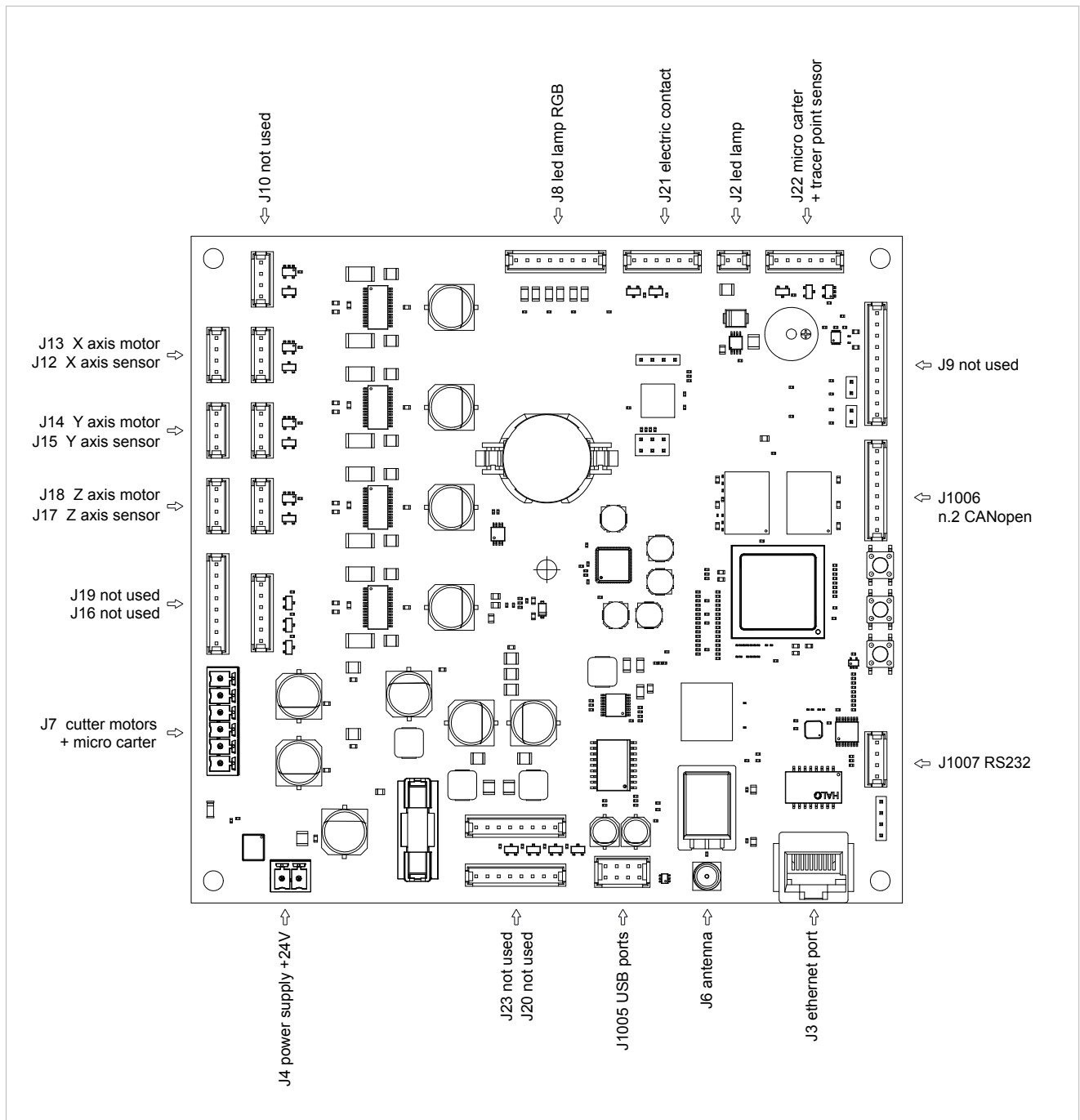
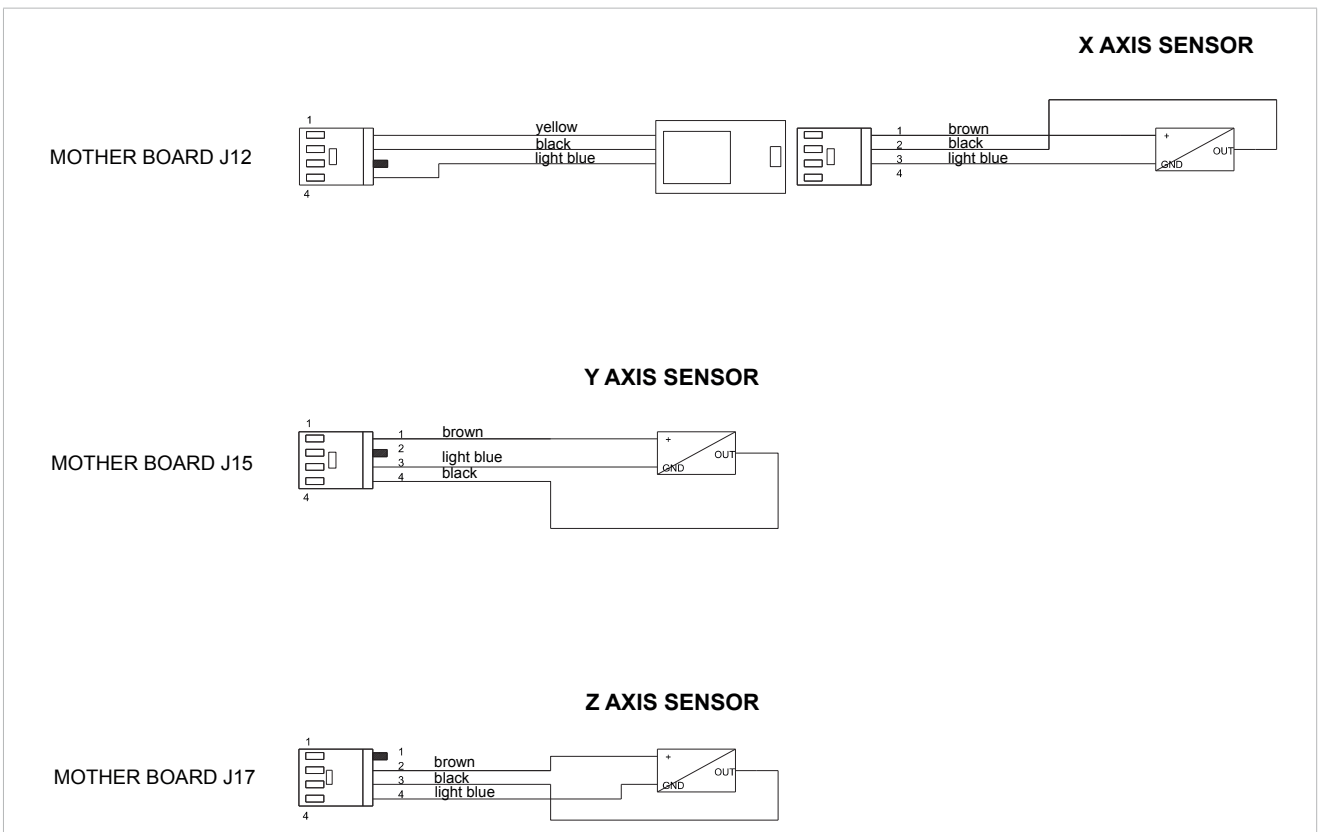
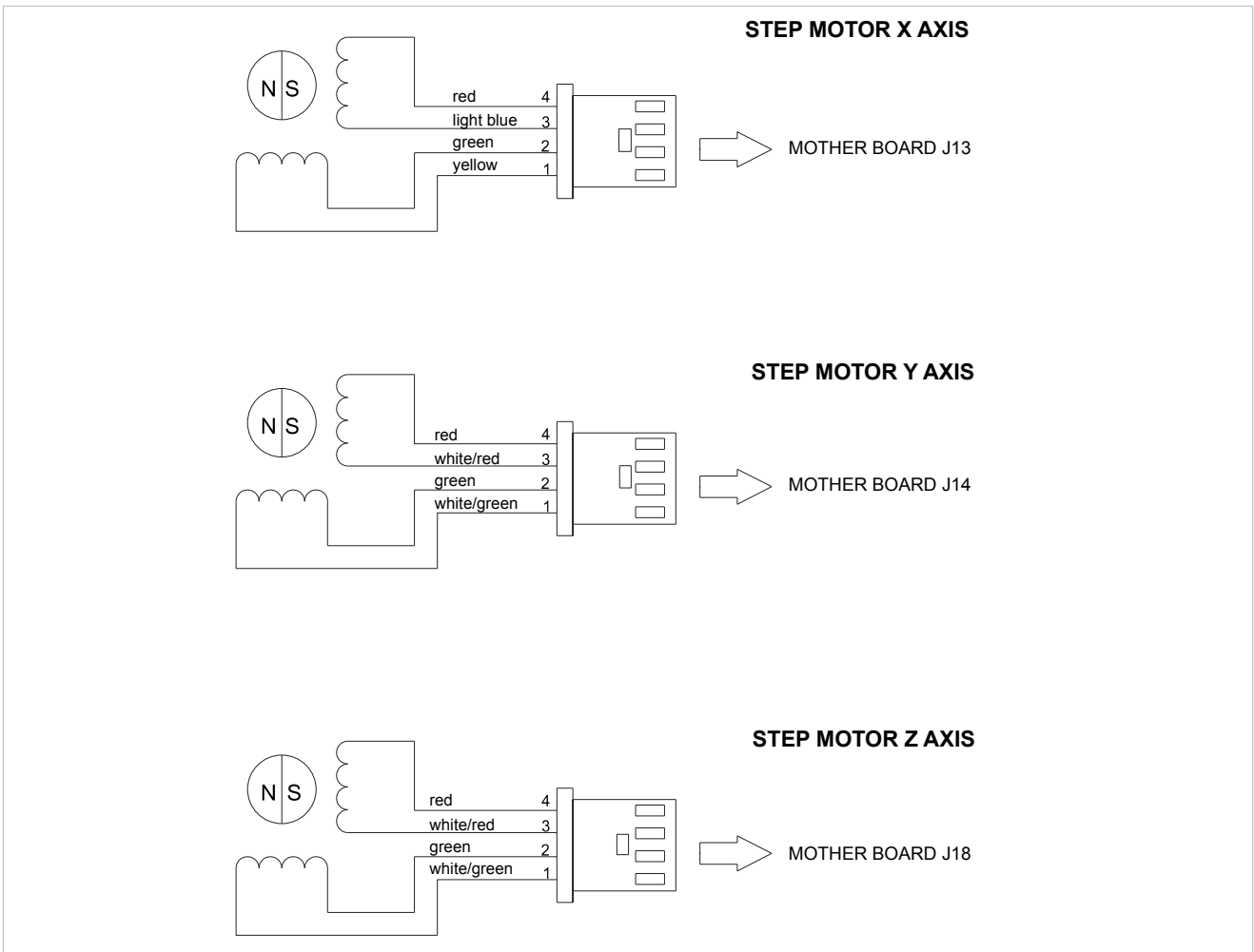
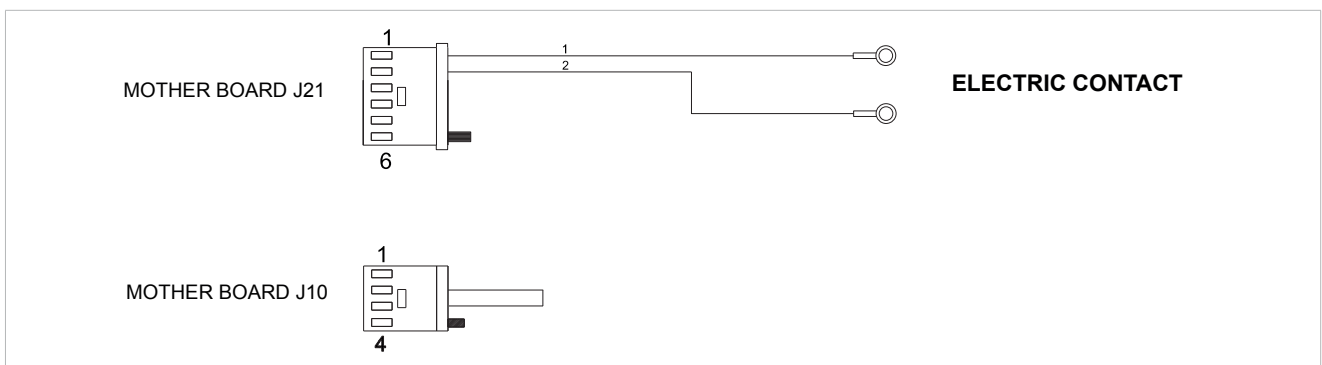
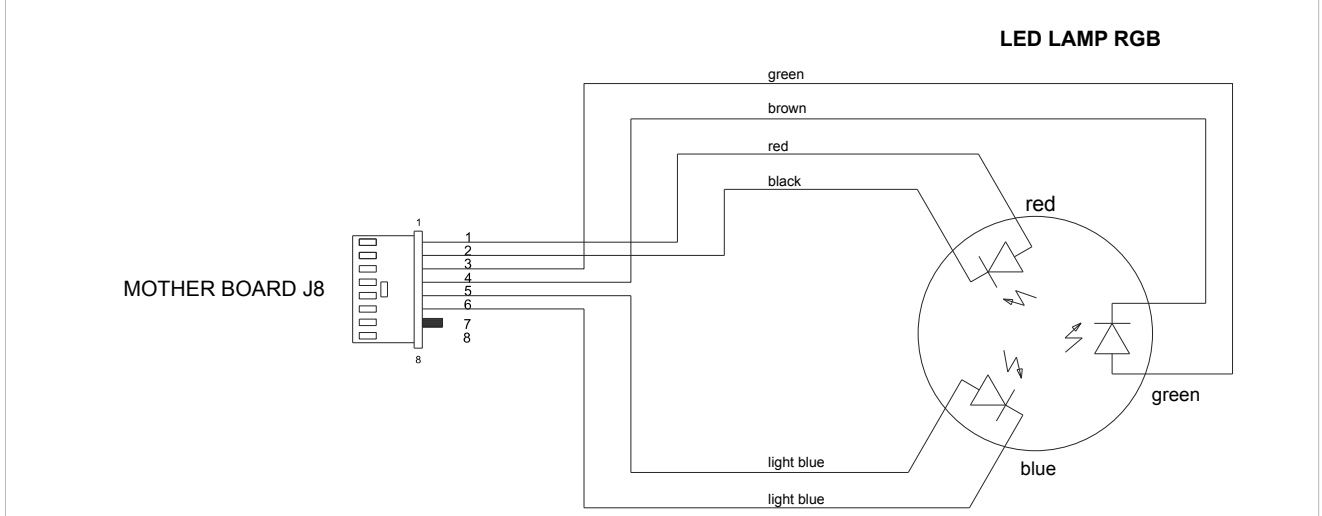
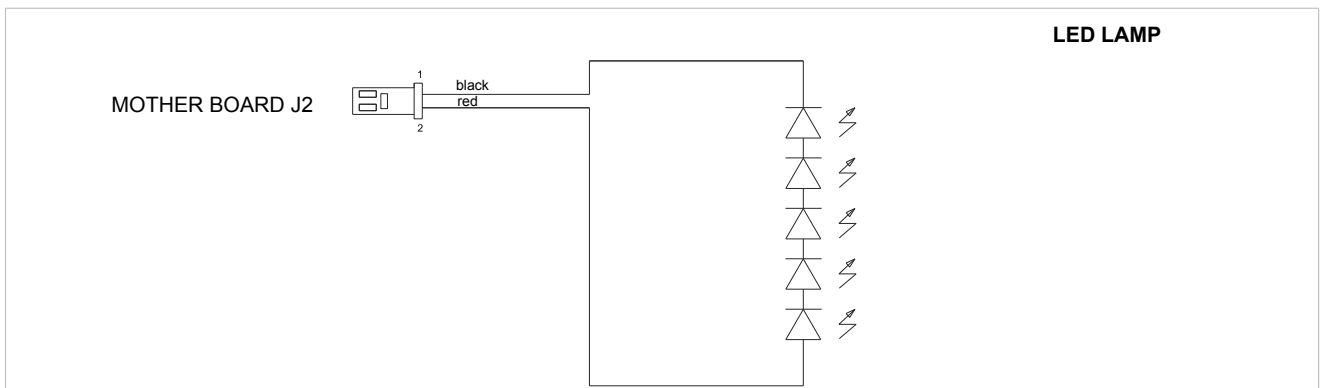
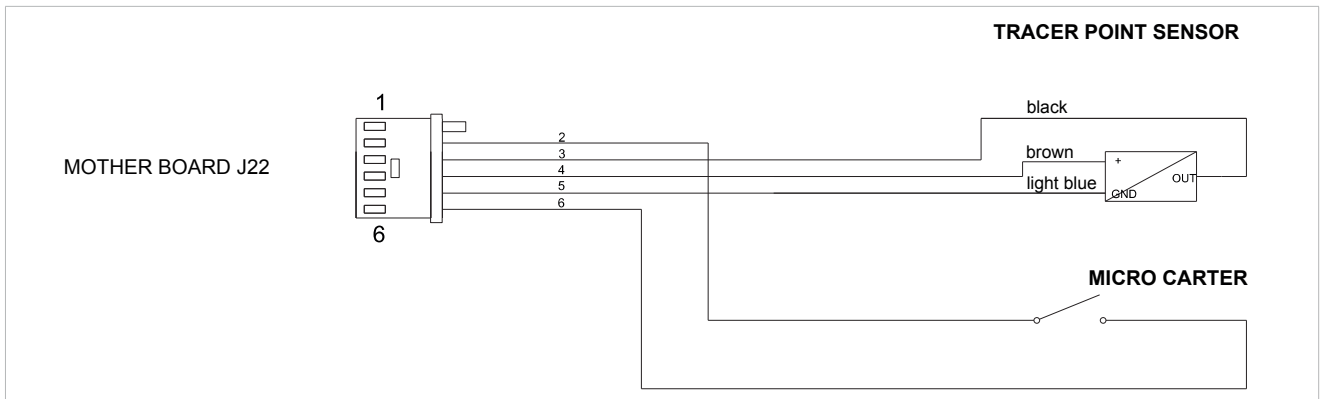

Fig. 57

11 ELECTRICAL DIAGRAMS







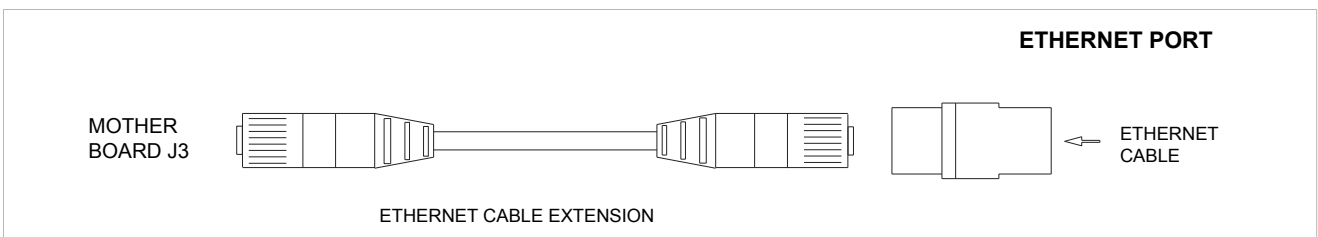
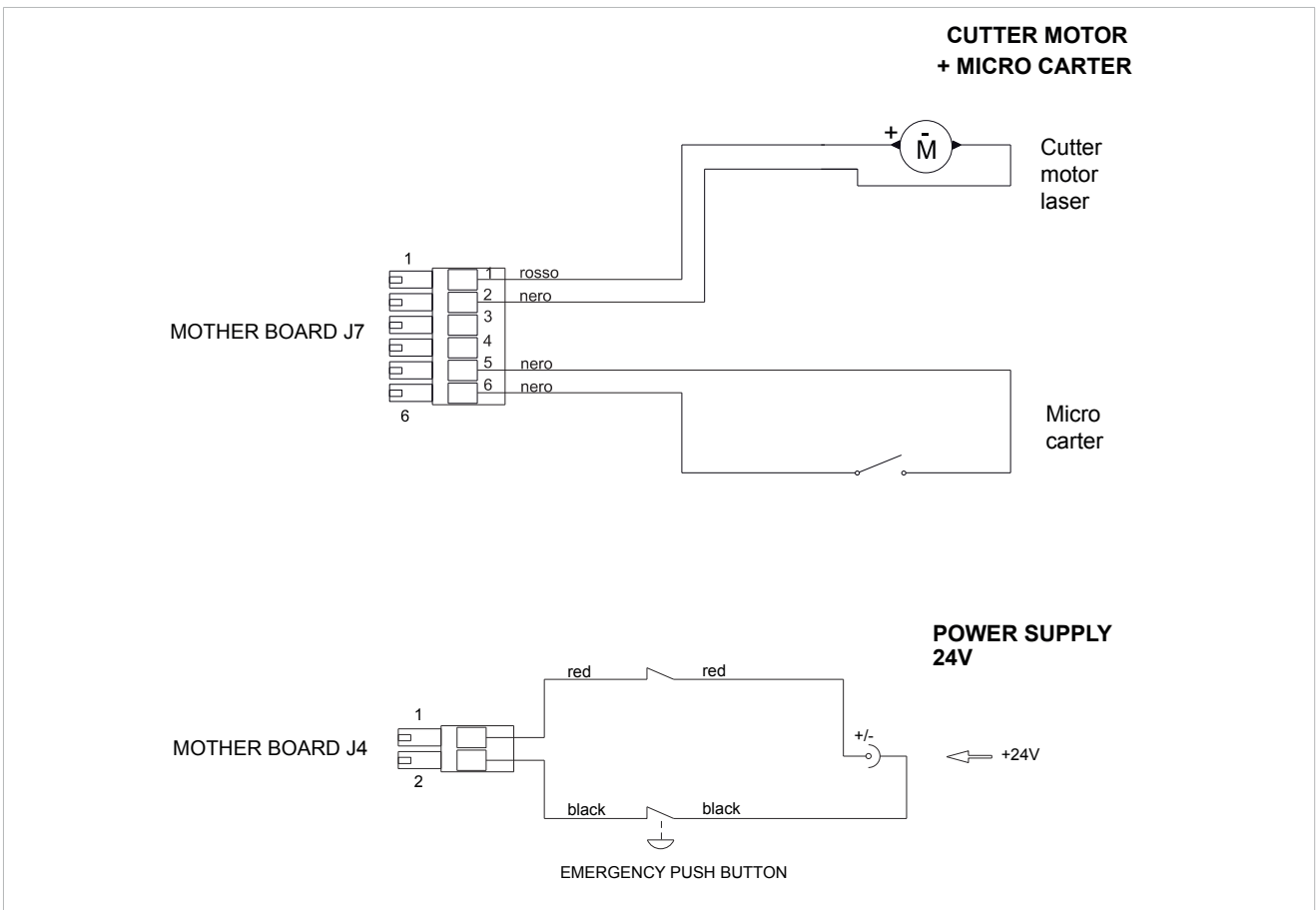
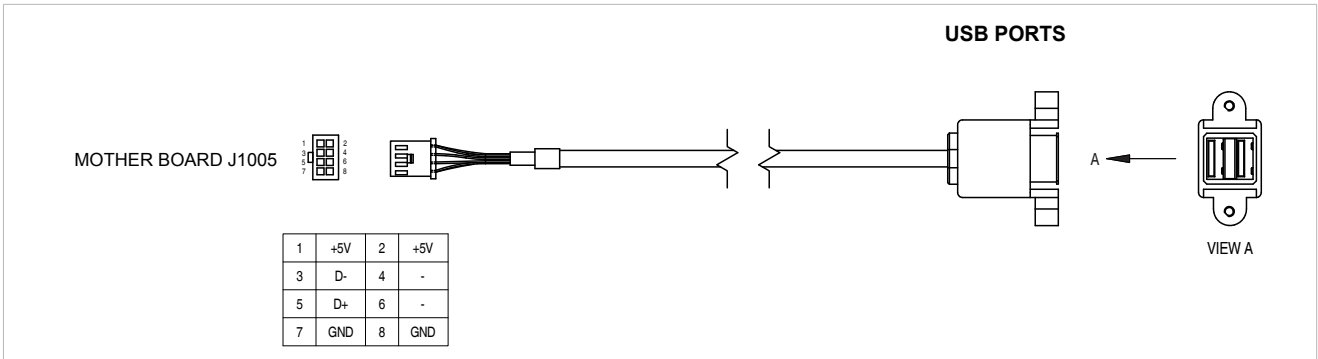

	EN	IT	DE	FR	ES	PT	NL
J2	Led lamp	lampada led	Led Lampe	Lampe Led	Lampara Led	Lâmpada Led	Led lamp
J3	Ethernet port	Porta ethernet	Ethernet-Anschluss	Port Ethernet	Puerto ethernet	Porta ethernet	Ethernetpoort
J4	Power feeder +24V	Alimentatore +24V	Speisegerat +24V	Alimentateur +24V	Alimentador +24V	Alimentador +24V	Voedingseenheid +24V
J5	USB port	Porta USB	USB-Anschluss	Port USB	Puerto USB	Porta USB	USB-poort
J6	Antenna	Antenna	Antenne	Antenne	Antena	Antena	Antenne
J7	Cutter motor + micro carter	Motore fresa + micro carter	Motor-Fräser + Mikro-Carter	Moteur fraise + micro carter	Motor fresa + micro carter	Motor fresa + micro carter	Freemotor + cover micro
J8	Led lamp RGB	Lampada Led RGB	Led Lampe RGB	Lampe Led RGB	Lámpara Led RGB	Lâmpada Led RGB	Led lamp RGB
J9	not used	non usato	nicht verwendet	non utilisé	no utilizado	não utilizado	niet gebruikt
J10	not used	non usato	nicht verwendet	non utilisé	no utilizado	não utilizado	niet gebruikt
J12	X axis sensor	Sensore asse X	Fuhler X-Achse	Senseur axe X	Detector eje X	Sensor eixo X	X-as sensor
J13	X axis motor	Motore asse X	Motor X-Achse	Moteur axe X	Motor eje X	Motor eixo X	X-as motor
J14	Y axis motor	Motore asse Y	Motor Y-Achse	Moteur axe Y	Motor eje Y	Motor eixo Y	Y-as motor
J15	Y axis sensor	Sensore asse Y	Fuhler Y-Achse	Senseur axe Y	Detector eje Y	Sensor eixo Y	Y-as sensor
J16	not used	non usato	nicht verwendet	non utilisé	no utilizado	não utilizado	niet gebruikt
J17	Z axis sensor	Sensore asse Z	Fuhler Z-Achse	Senseur axe Z	Detector eje Z	Sensor eixo Z	Z-as sensor
J18	Z axis motor	Motore asse Z	Motor Z-Achse	Moteur axe Z	Motor eje Z	Motor eixo Z	Z-as motor
J19	not used	non usato	nicht verwendet	non utilisé	no utilizado	não utilizado	niet gebruikt
J20	not used	non usato	nicht verwendet	non utilisé	no utilizado	não utilizado	niet gebruikt
J21	Electric contact	Contatto elettrico	Elektrische Kontakt	Contact électrique	Contacto eléctrico	Contato elétrico	Elektrisch contact
J22	Micro cover + tracer point sensor	Micro carter + sensore tastatore	Mikro Carter + Taster Fühler	Micro carter + senseur palpador	Micro carter + sensor palpador	Micro carter + sensor palpador	Cover micro + sensor tracer punt
J23	not used	non usato	nicht verwendet	non utilisé	no utilizado	não utilizado	niet gebruikt
J1005	USB ports	Porte USB	USB-Anschlüsse	Ports USB	Puertos USB	Portas USB	USB-poorten
J1006	n.2 CANopen	n.2 CANopen	n.2 CANopen	n.2 CANopen	n.2 CANopen	n.2 CANopen	n.2 CANopen
J1007	RS232	RS232	RS232	RS232	RS232	RS232	RS232



EU DECLARATION OF MACHINE COMPLIANCE

**SILCA S.p.A. - VIA PODGORA 20 (Z.I.)
31029 VITTORIO VENETO (TV) - (ITALY)
TEL. 0438 9136 - FAX. 0438 913800**

Declares under its own responsibility that the **Key-Cutting Machine** model

**FUTURA PRO ONE
FUTURA PRO ONE A.**

Serial Number _____

complies with the requirements of the following European Directives:

European Union **DIRECTIVE 2006/42/EC** (Machines)
European Union **DIRECTIVE 2014/30/EU** (Electromagnetic Compatibility)
European Union **DIRECTIVE 2014/53/EU** (RED)
European Union **DIRECTIVE 2014/35/EU** (Low Voltage) | **16** |

and with the following Standards:

EN 55032:2015	ETSI EN 300 328:2015 (V1.9.1)
EN 55022:2010	EN 60825-1:2014
EN 55024:2010	EN 62471:2015
EN 61000-3-2:2014	EN 60950-1:2006 + A11:2009 + A1:2010 + A12:2011 + A2:2013
EN 61000-3-3:2008	EN ISO 12100:2010
EN 301 489-1:2011 (V1.9.2)	EN 62233:2008
EN 301 489-17:2012 (V2.2.1)	

Maurizio Ugel of the Silca S.p.A. R&D Division is authorized to create a Technical File.

VITTORIO VENETO 26/10/2016

General Manager Basic Production Center

Stefano Setti

SILCA S.p.A.
Via Podgora, 20 (Z.I.)
31029 Vittorio Veneto (TV) Italy

A Member of the Kaba Group

Tel. +39 0438 9136 Fax +39 0438 913800 www.silca.it info@silca.it
P. IVA C.F. e Reg. Impr. IT03286730266 REA TV 258111
Cap. Soc. € 10.000.000 i.v. Export TV 038851

Società soggetta a direzione e coordinamento di Kaba Holding AG, con sede in Rümlang (Svizzera),
Hofwisenstrasse 24, ai sensi e per gli effetti degli articoli 2497 - 2497sexies del Codice Civile.



