



In or Out... we make it Easy!®

PDD-FT-3

**Fire Panel Interface
With EOL Trigger**

Installation and Specifications Manual

Details

The PDD-FT-3 board is a fire panel control interface. This board can be used to control DC output based on a fire alarm control panel. Two outputs switch state on alarm.

Features

- Non Latching or Latching mode
- Universal 12VDC or 24VDC Operation
- Reverse polarity protected
- Normally ON & Normally OFF Output
- Output LED's indicate condition
- Outputs can be Triggered with:
 - 1) N/O or N/C Switch with Supervised End of Line Resistor (EOL)
 - 2) N/C Switch with (OVR) over ride
 - 3) N/C Switch with (AUX-IN) auxiliary
 - 4) Ground on any trigger input when (GRN) Jumper is enabled
- Form C DPDT Relay Indicates Trigger Status
- 3 Amp Transfer Relay Contacts
- Auto or manual reset by jumper selection

Installation Instructions

1. Mount the PDD-FT-3 board in a suitable location in close proximity to the power supply.

Note:

- a) Ground fault detection will only work if conductive stand offs are used and power supply enclosure is properly grounded.
 - b) As this device can be used to power multiple devices ensure that all wiring is of an appropriate gauge for the devices being installed.
 - c) This RCI board is for use in a controlled indoor environment. The PDD-FT-3 and all devices connected to or powered through the PDD-FT-3 shall be installed within the same continuous building structure. Installation must be in accordance with local building and fire codes. Check with Authority Having Jurisdiction (AHJ) for details prior to installing.
 - d) All power limited wiring must be a minimum of .25" from non-power limited wiring.
 - e) Maximum torque of 7 in*lb for black input and output terminals.
2. Connect "INPUT" terminals to output of DC supply, paying close attention to polarity of DC output from power supply.
 3. Connect devices to be powered to output terminals of PDD-FT-3 control board, paying close attention to polarity requirements. Minimum 22AWG and maximum distance of 6170ft. for field wiring.
 4. Set jumpers (RST, OVR, AUX, and GRN) as required for proper installation.

5. Connect fire alarm control panel to EOL input terminals, ensure the 2.2K resistor is installed at the terminals in the fire alarm panel.
 - a) See fire alarm control panel installation and operation manual for details about signaling requirements.
 - b) Fig's 2-6 in this installation guide will provide details on wiring to the fire alarm control panel.
6. Connect any required monitoring equipment to the trigger relays using appropriate cabling.
7. This unit is to be powered from a 10 Series RCI Power Supply or a UL listed power supply.
8. Apply power to power supply to activate control board and test all connected devices.

Specifications

- **For UL listed power supply**
- **UL 294 6e and ULC S319 Class 1 Access Control System Unit**

Access Control Levels:

Endurance: Level 4 Line Security: Level 1
Power Standby: Level 1 Destructive Attack: Level 1

Input

- Input Voltage: 12 or 24VDC \pm 10%
- Typical Current Draw with no Output Load: 10mA @ 12VDC
15mA @ 24VDC

Output

- Output Relay Rating: 3A

Monitor Inputs

- EOL (End of Line) Trigger: Trigger at + or – 50% of 2.2K
- OVR Trigger
- AUX Trigger
- Reset Input
- Ground Fault Trigger (see note 1a)

Monitor Outputs

- Trigger Relay Rating: 1A DPDT

Environmental

- Use in a controlled indoor environment

Warning: Improper wiring connections may result in damage to this product.

Mise en garde: Un mauvais raccordement des câbles risque d'endommager ce produit.

Description of PDD-FT-3 Connections See Fig. 1

Input Power

“-INPUT+”: 2 position terminal block with self clamping screws will accept multiple 12AWG wires Universal input.

Output Power

Two, 2 position terminal blocks. Self clamping screws will accept multiple 12AWG wires. “-N/ON+” are normally ON output power. This output is ON when the PDD-FT-3 is not triggered. “-N/OFF+” is normally OFF. This output is ON when this unit is triggered. The transfer relay is rated at 3 Amps.

Power LED's

A red led above each output indicates which output is active.

Input Trigger EOL*

2 position terminal block – Will accept 12AWG wire. This input must see the 2.2K ohm end of line resistor to be in the normal set condition. A change in resistance of $\pm 50\%$ will cause the trigger relays to drop out in the Triggered mode. This change in resistance is caused by the supervised wire between the EOL at the fire panel and the PDD-FT-3 being shorted or opened. The EOL supervises the pair of wires.

Input Trigger OVR*

2 position terminal block - Will accept 12AWG wire. This pair is normally closed and can be connected to an override switch. When OVR is open, unit will trigger.

Input Trigger AUX-IN*

2 position terminal block - Will accept 12AWG wire. This pair is normally closed and can be connected to an auxiliary device. When AUX-IN is open, unit will trigger.

Reset 2 Position Terminal Block*

2 position terminal block - Will accept 12AWG wire. When this pair is shorted, input triggers do not latch. If pair is open, the input triggers will latch until alarm is corrected and RESET is momentary closed to reset trigger.

***Minimum 22AWG and maximum distance of 6170ft for field wiring.**

Jumpers RST - OVR - AUX

Jumpers are used to activate (remote) features as required.

Jumpers GRN

This jumper is used to enable ground supervision or the inputs. If the jumper is connected to both headers, and the mounting hole adjacent to jumper is connected to earth ground, a ground on any of the input triggers will cause a trigger.

Trigger Status Terminal block

Two, 3 position terminal blocks - Will accept 12AWG wire. Form C DPDT relay with a 1 Amp rating will indicate the condition of trigger. C and NO are normally open in the normal energize not triggered state. C and NC are normally closed in the normal energized not triggered state. These contacts may be used to provide feedback to the FACP or other auxiliary devices.

Fig. 1 - PDD-FT-3 Connections

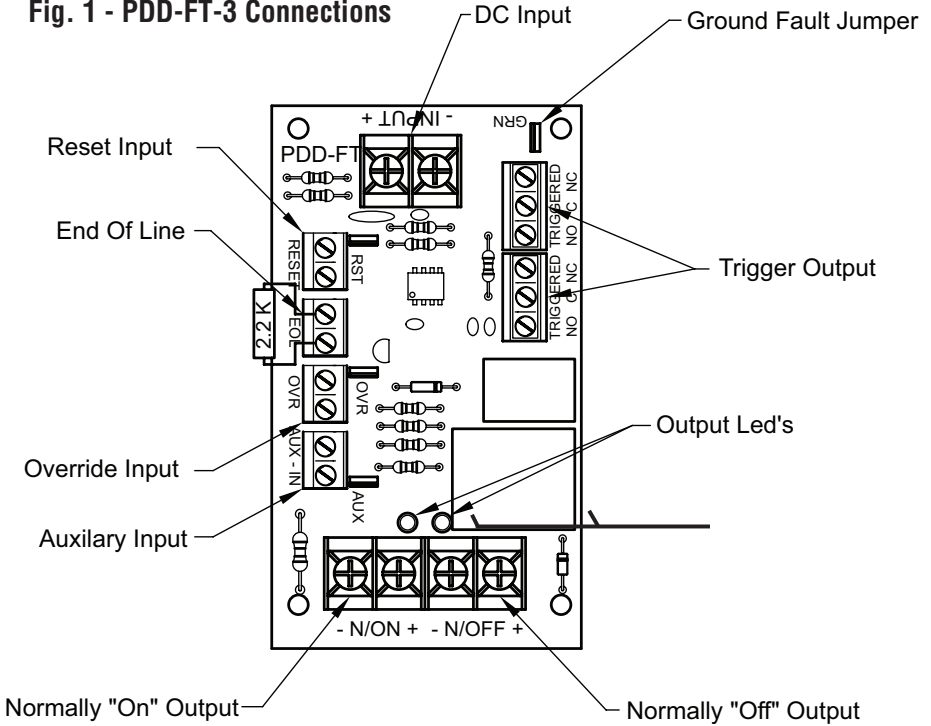

Application Diagrams

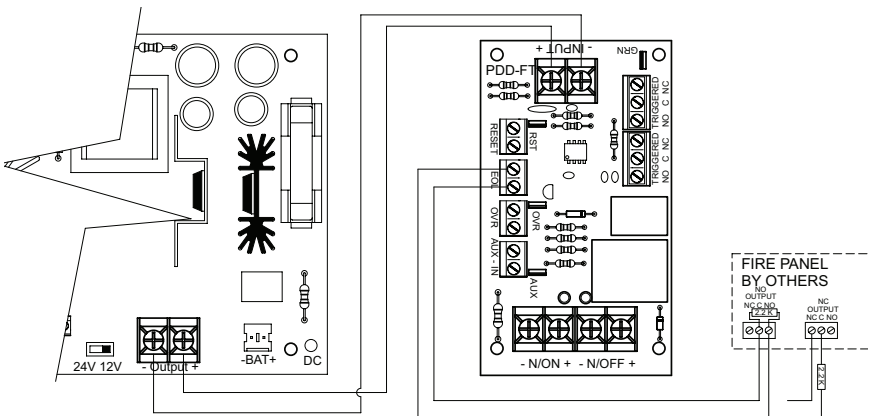

Fig. 2 - Fire Panel Connections for Non-Latching Automatic Reset Operation

This application illustrates how to connect the PDD-FT-3 to a power supply for main input as well as a fire alarm control panel. If wired in this manner, outputs will change state only as long as the fire alarm relay is active. When the fire alarm resets the PDD-FT-3 outputs will also reset.

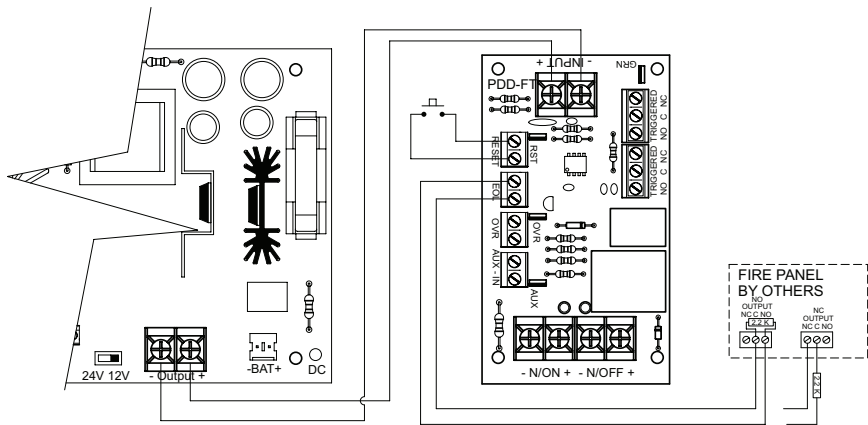

Fig. 3 - Fire Panel Connections for Latching Release with N/O Manual Reset

This application illustrates how to connect the PDD-FT-3 to a power supply for main input as well as a fire alarm control panel. If wired in this manner, outputs will change state whenever the fire alarm relay activates and remain latched in the triggered state until reset by activating the N/O switch.

Note: Remove RST jumper for manual reset operation.

Remarque: Retirez la bretelle RST pour effectuer une réinitialisation manuelle.

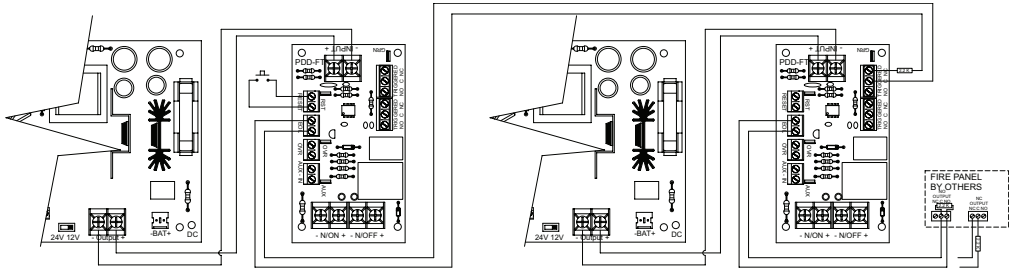

Fig. 4 - Connections for Non-Latching release reset using multiple PDD-FT-3 boards

This application illustrates how to connect the PDD-FT-3 to a power supply for main input as well as a fire alarm control panel. If wired in this manner, outputs will change state only as long as the fire alarm relay is active. When the fire alarm resets the PDD-FT-3 outputs will also reset. Connecting the EOL input of one board to the trigger relay of the next board as shown will allow for override and reset of multiple boards.

Note: The RST jumper must be left in place on all boards for automatic reset operation.

Remarque: La bretelle RST doit être laissée en place sur tous les panneaux pour effectuer une réinitialisation automatique.

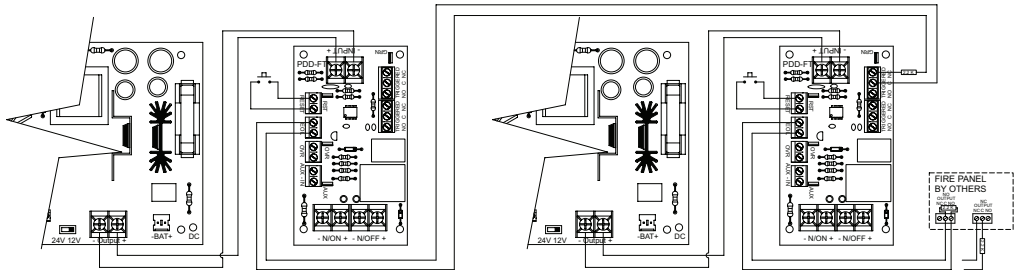

Fig. 5 - Connections for latching release with N/O manual reset using multiple PDD-FT-3 boards (Master & Slave)

This application illustrates how to connect the PDD-FT-3 to a power supply for main input as well as a fire alarm control panel. If wired in this manner, outputs will change state whenever the fire alarm relay activates and remain latched in the triggered state until Master is reset by activating the N/O switch. Connecting the EOL input of one board to the trigger relay of the next board as shown will allow for reset of multiple boards.

Note: The RST jumper must be left in place on all slave boards except the one that is directly connected to the fire alarm (Master), reset, and switches.

Remarque: La bretelle RST doit être laissée en place sur tous les panneaux asservis, sauf celui qui est directement connecté à l'alarme de feu (d'exploitation), situé près des boutons de réinitialisation et d'annulation.

Fig. 6 - Fire Panel Connections for Latching Trigger with N/O Manual Reset and N/C override with Battery Backup

This application illustrates how to connect the PDD-FT-3 to an RCI Power Supply for main input, AC failure as well as a fire alarm control panel. If wired in this manner, trigger outputs will change state whenever the fire alarm, or AC failure relays activate. The PDD-FT-3 outputs will remain in the triggered state until both relays have been reset and the N/O manual reset is triggered.

Note: Ensure jumpers for RST, OVR, and AUX IN are removed to allow terminals to operate correctly.

Remarque: Assurez-vous que les bretelles RST, OVR et AUX IN sont retirées afin de permettre aux terminaux de fonctionner correctement.

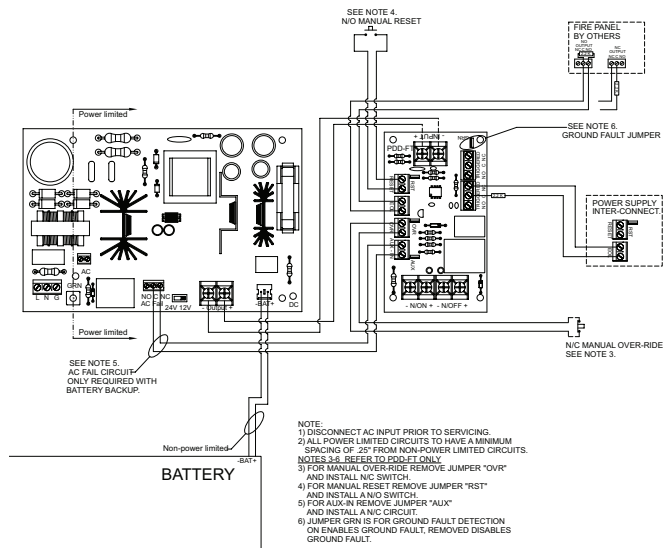

- NOTE:
- 1) DISCONNECT AC INPUT PRIOR TO SERVICING.
 - 2) ALL POWER LIMITED CIRCUITS TO HAVE A MINIMUM SPACING OF .25" FROM NON-POWER LIMITED CIRCUITS.
- NOTES 3-6 REFER TO PDD-FT ONLY
- 3) FOR MANUAL OVER-RIDE REMOVE JUMPER "OVR" AND INSTALL N/C SWITCH.
 - 4) FOR MANUAL RESET REMOVE JUMPER "RST" AND INSTALL AND SWITCH.
 - 5) FOR AUX IN REMOVE JUMPER "AUX" AND INSTALL A N/C CIRCUIT.
 - 6) JUMPER GEN IS FOR GROUND FAULT DETECTION ON ENABLES GROUND FAULT, REMOVED DISABLES GROUND FAULT.

PDD-FT-3 Troubleshooting Guide

Problem	Solution
No DC output from terminals.	<ul style="list-style-type: none">- Check AC Power.- Check Power Supply for voltage output.- Check devices connected to outputs for a short circuit. (PTC's may require short to be removed for several minutes before automatically resetting).- Check trigger jumpers. Output LED should be lit if output is active.
Trigger is active and will not reset.	<ul style="list-style-type: none">- Check for proper wiring connections on trigger connections.- Ensure that 2.2K resistor is installed at End of Line position in the wiring.
Trouble output relay is de-energized. (Relay terminals are labeled shown in the Normal, energized, "no trouble" condition. Relays are energized when no trouble is detected.)	<ul style="list-style-type: none">- Check devices connected to outputs for a short circuit. (PTC's may require short to be removed for several minutes before automatically resetting.)

Notes

For Technical Support:

1.800.265.6630 | WWW.RUTHERFORDCONTROLS.COM