

GT Omega

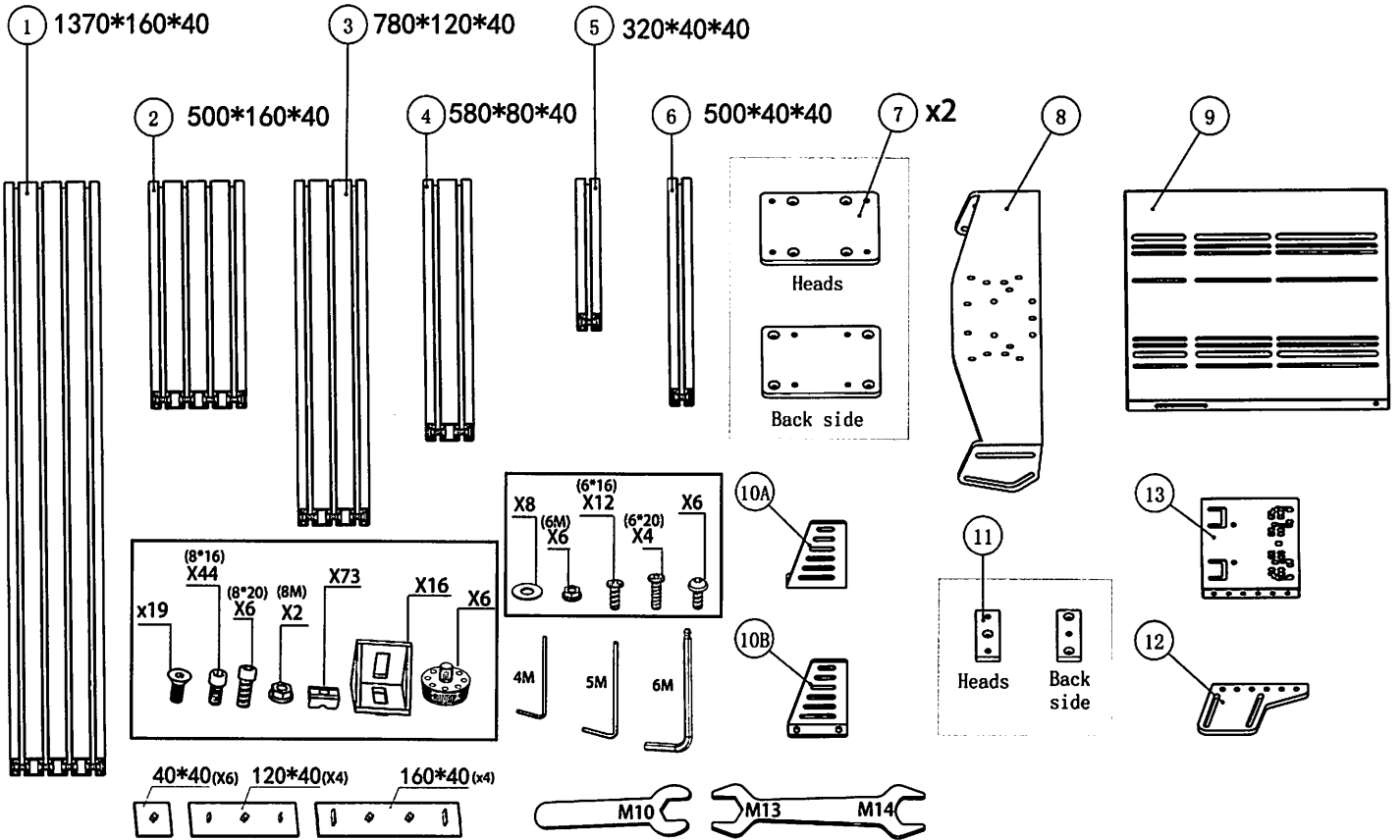

GT Omega

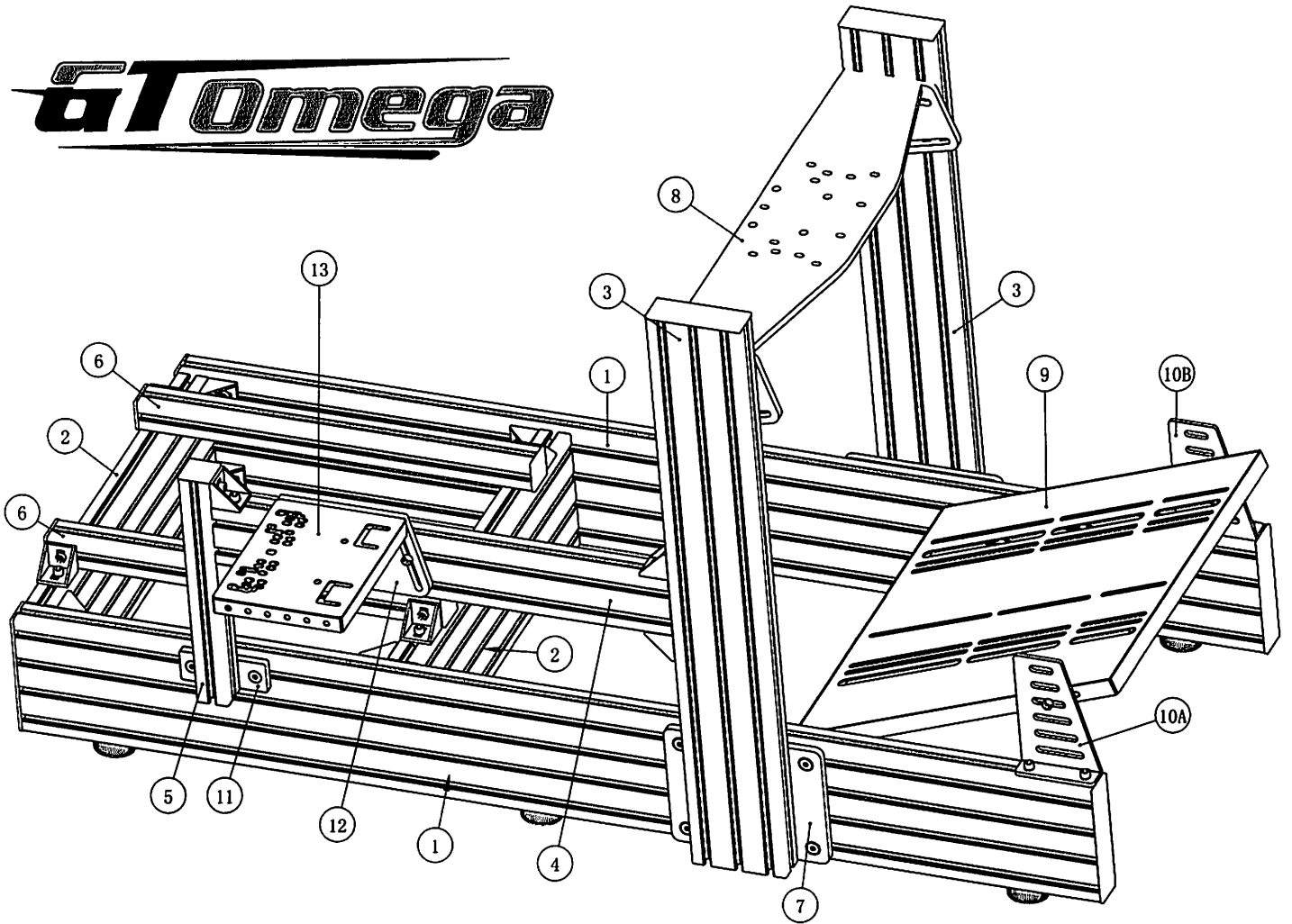

Method 1

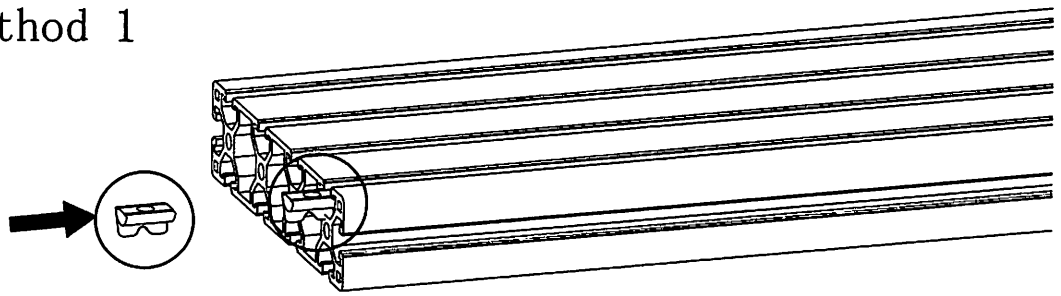

Method 2

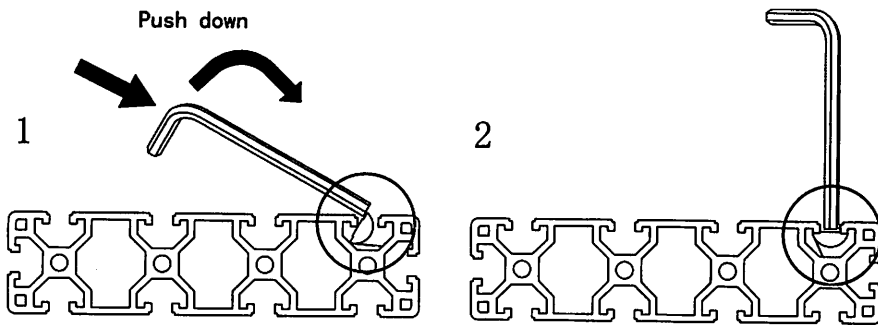

1

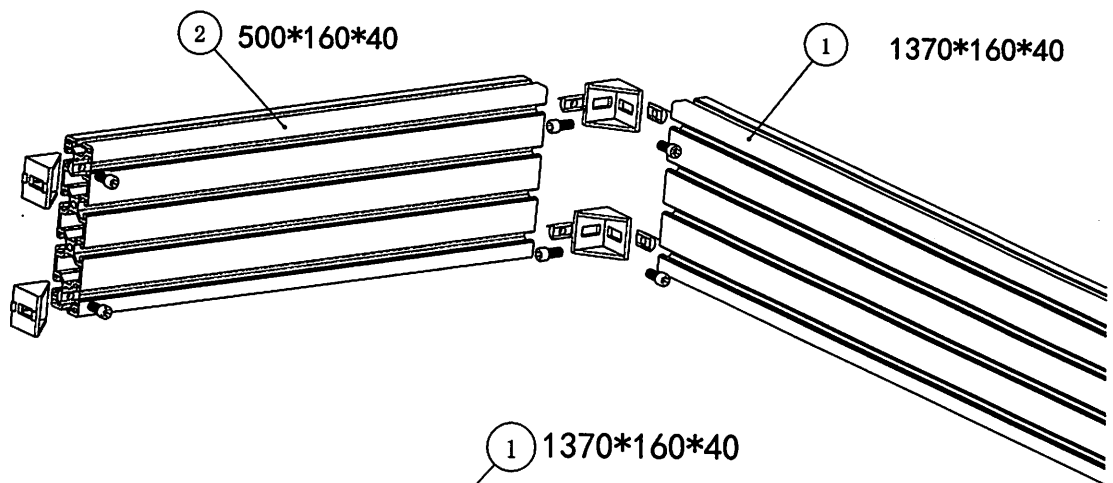

2

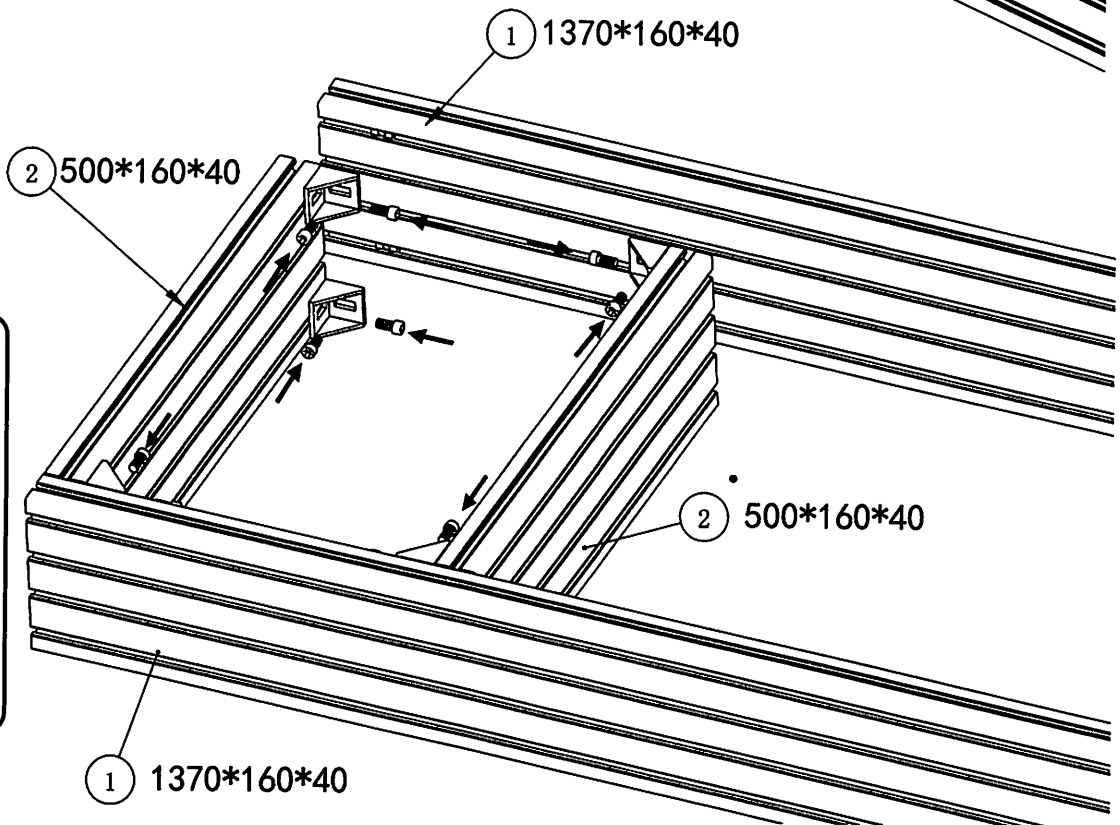

- (8*16) 8M x16
- x16
- x16
- x8

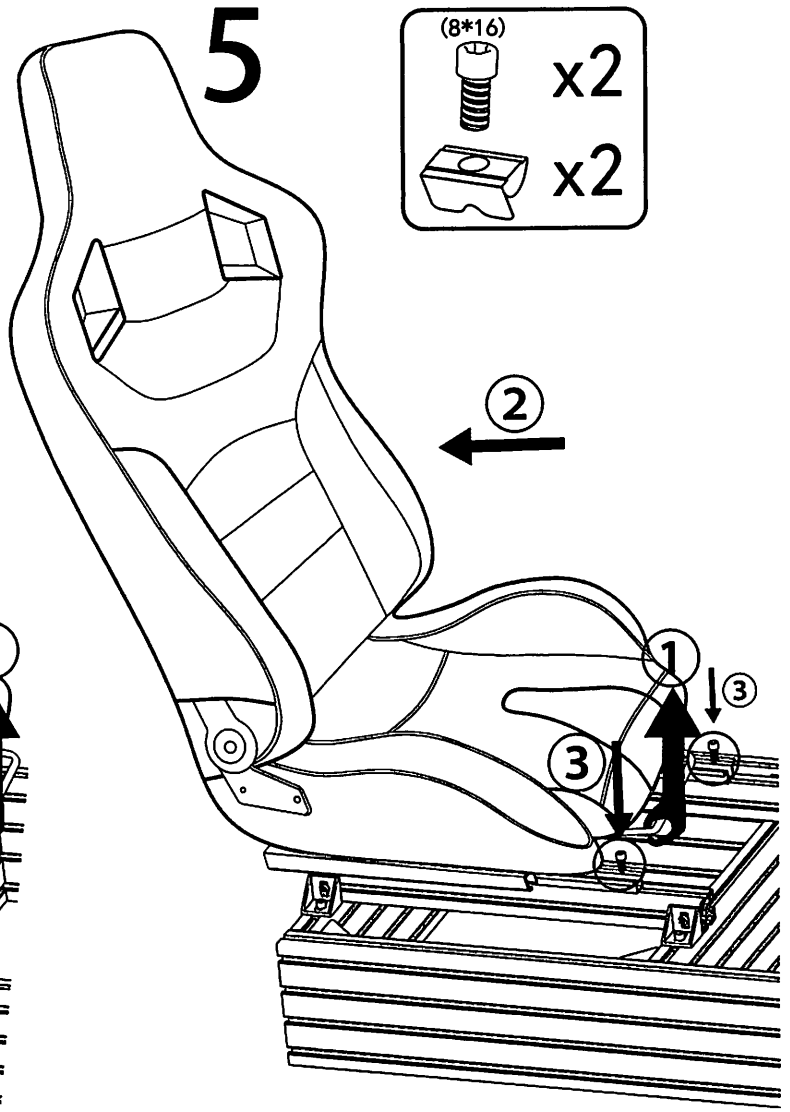
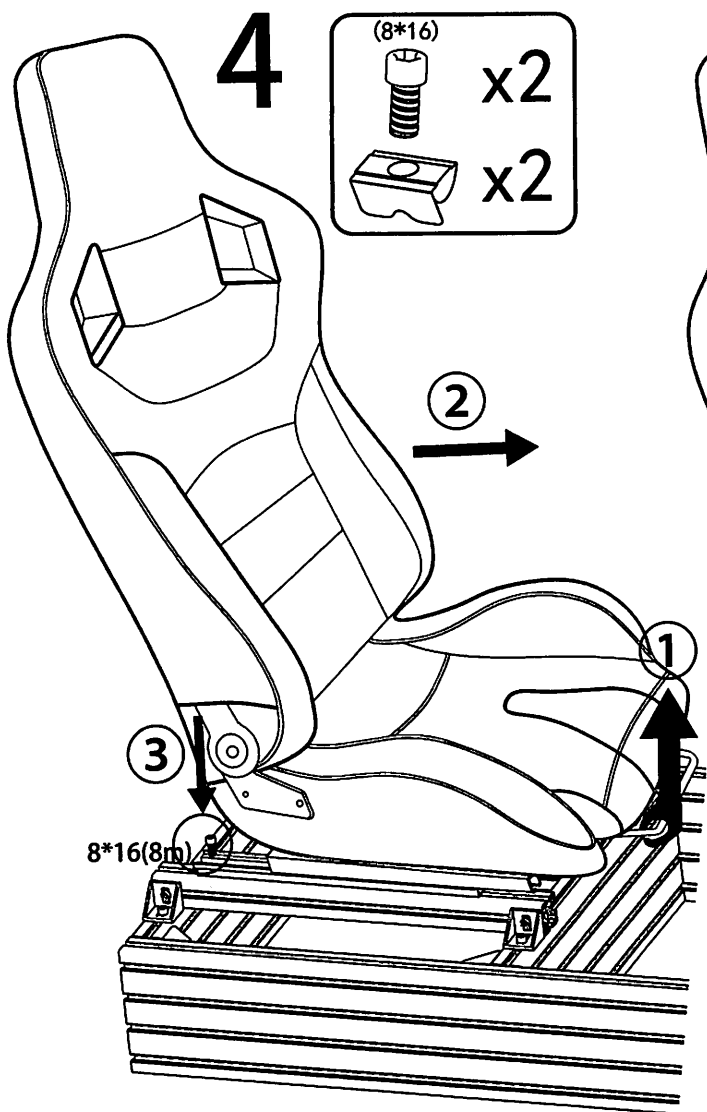
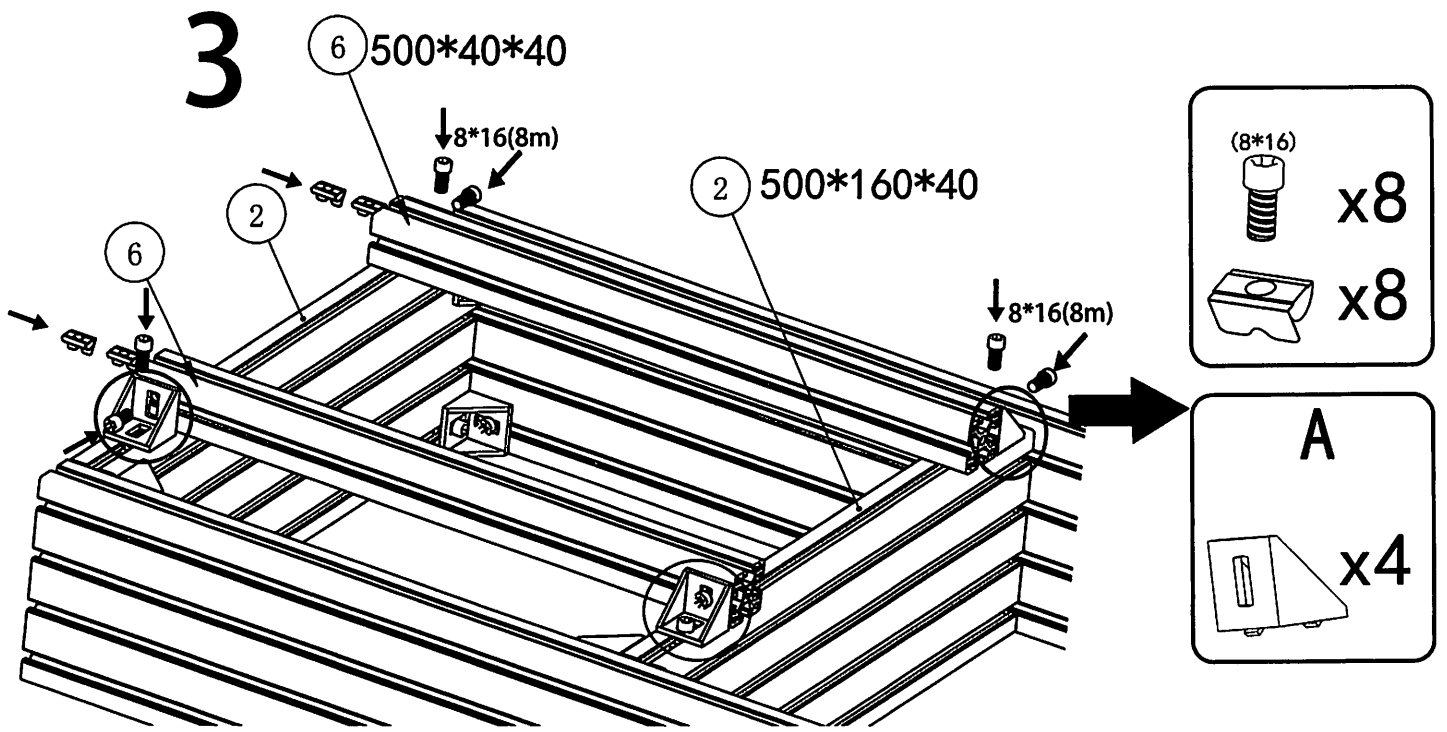

6

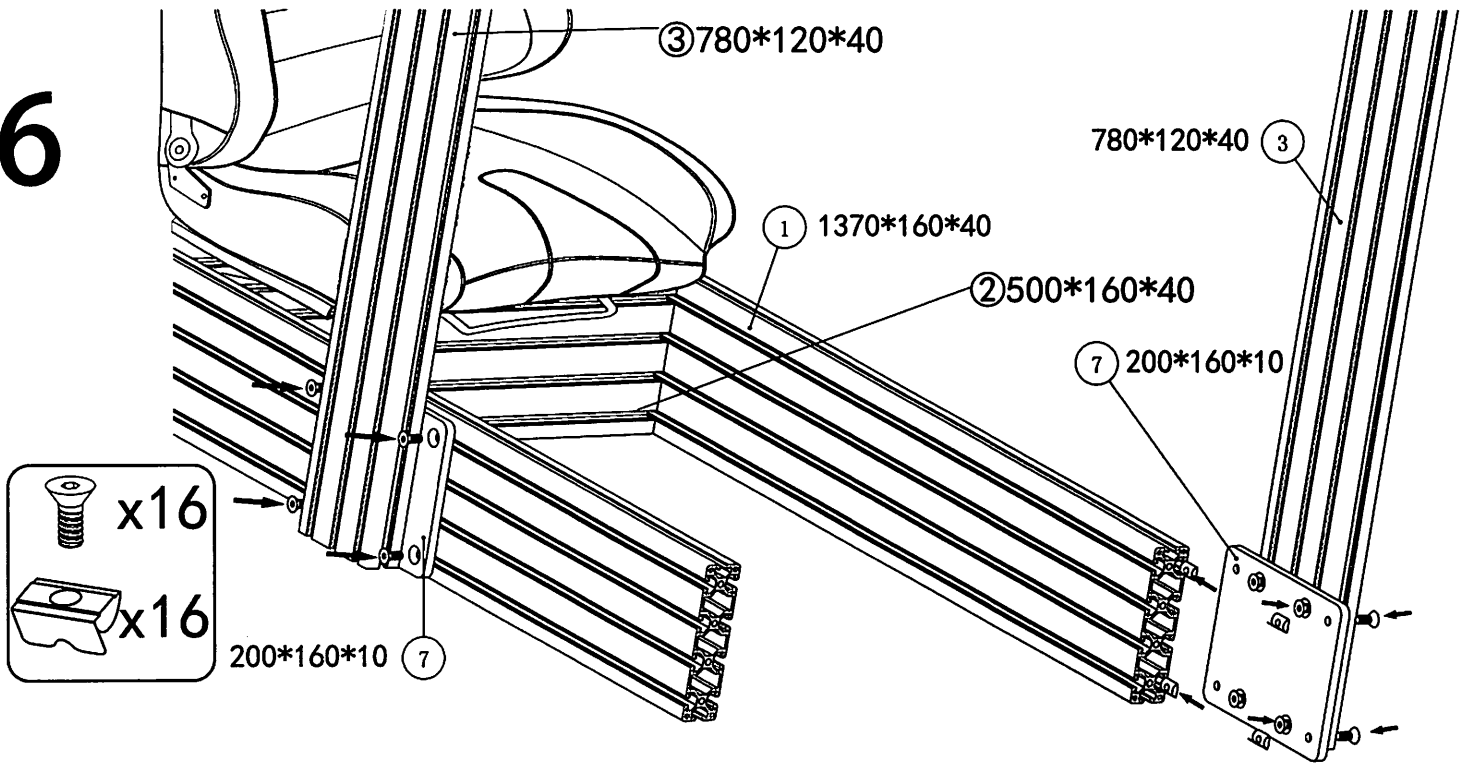

7

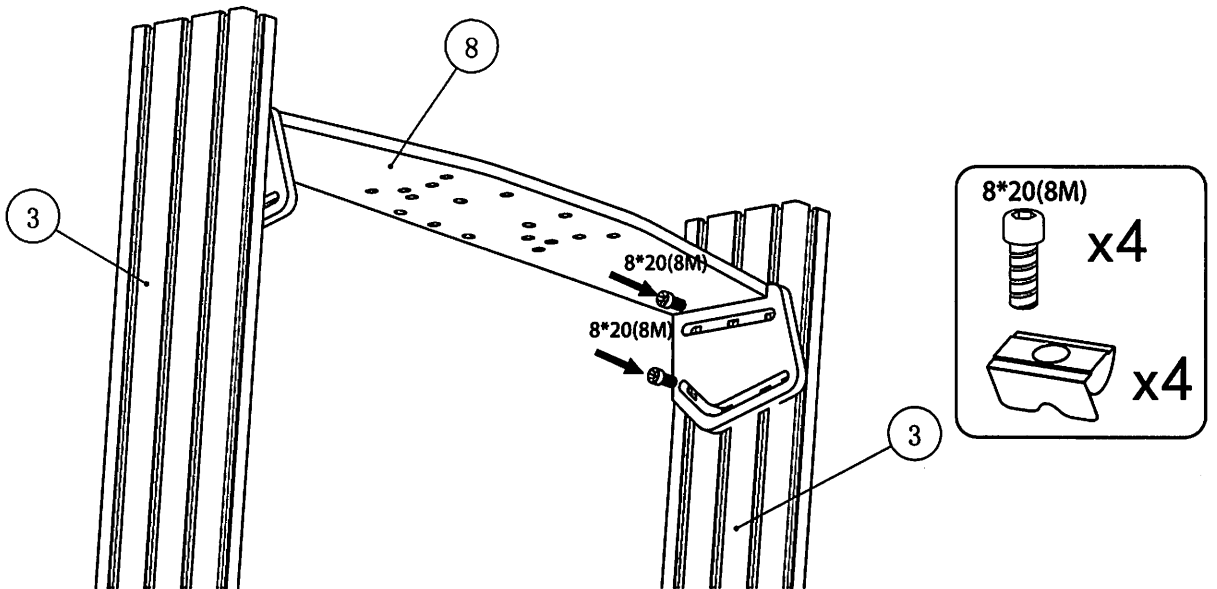

8

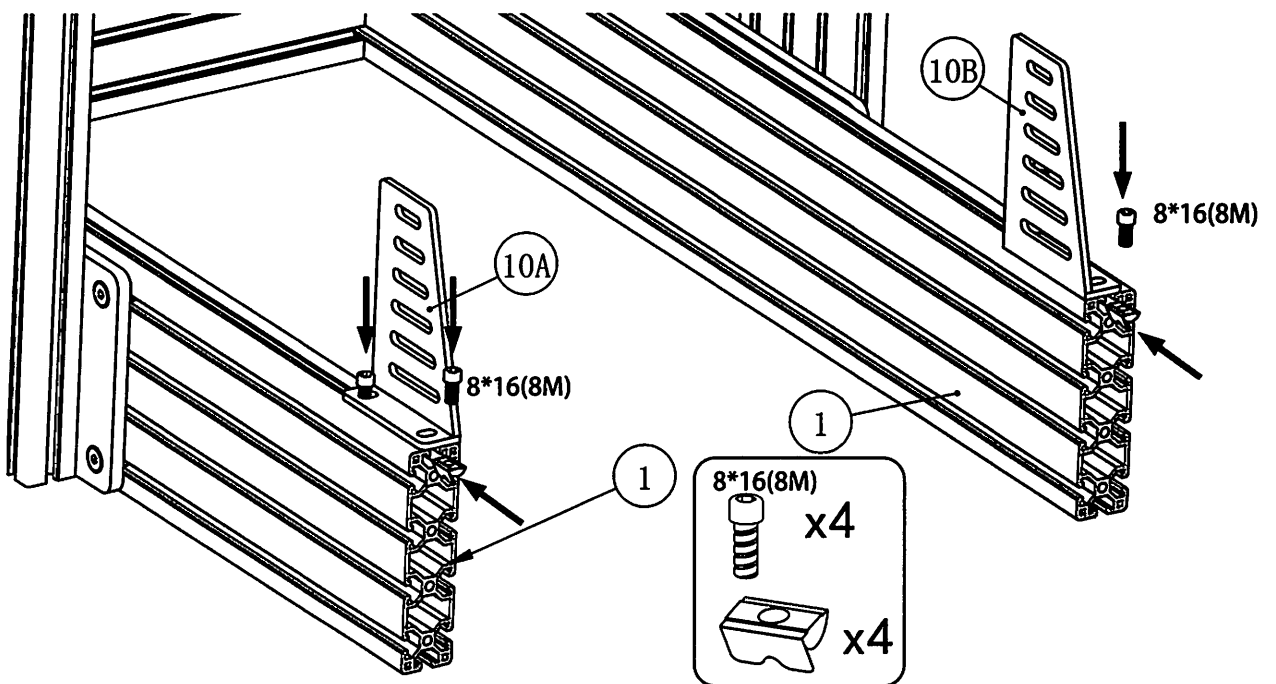

9

8*16(8M) x4
8M x2
x2

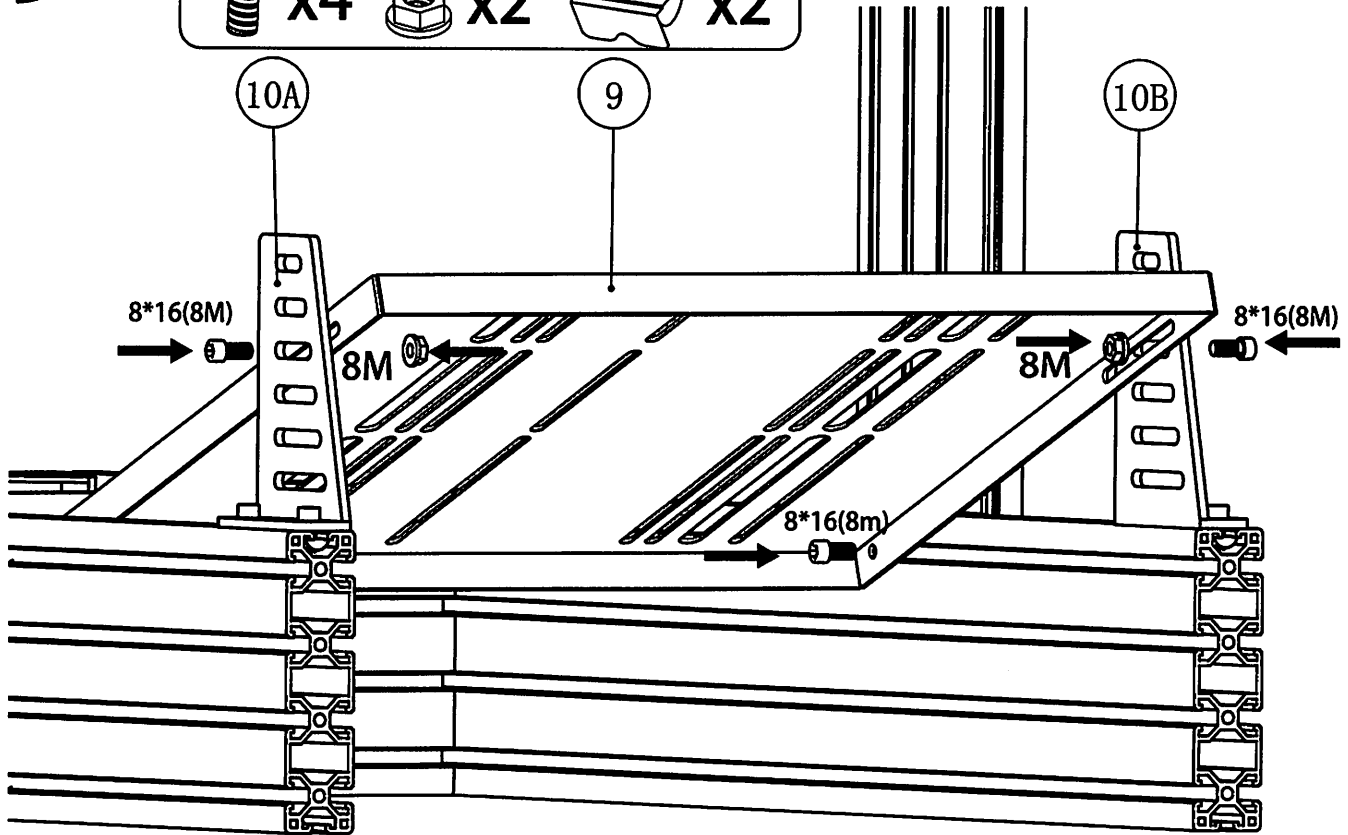

10

8*16(8M) x6
x9
8*20(8M) x2
x1
x4

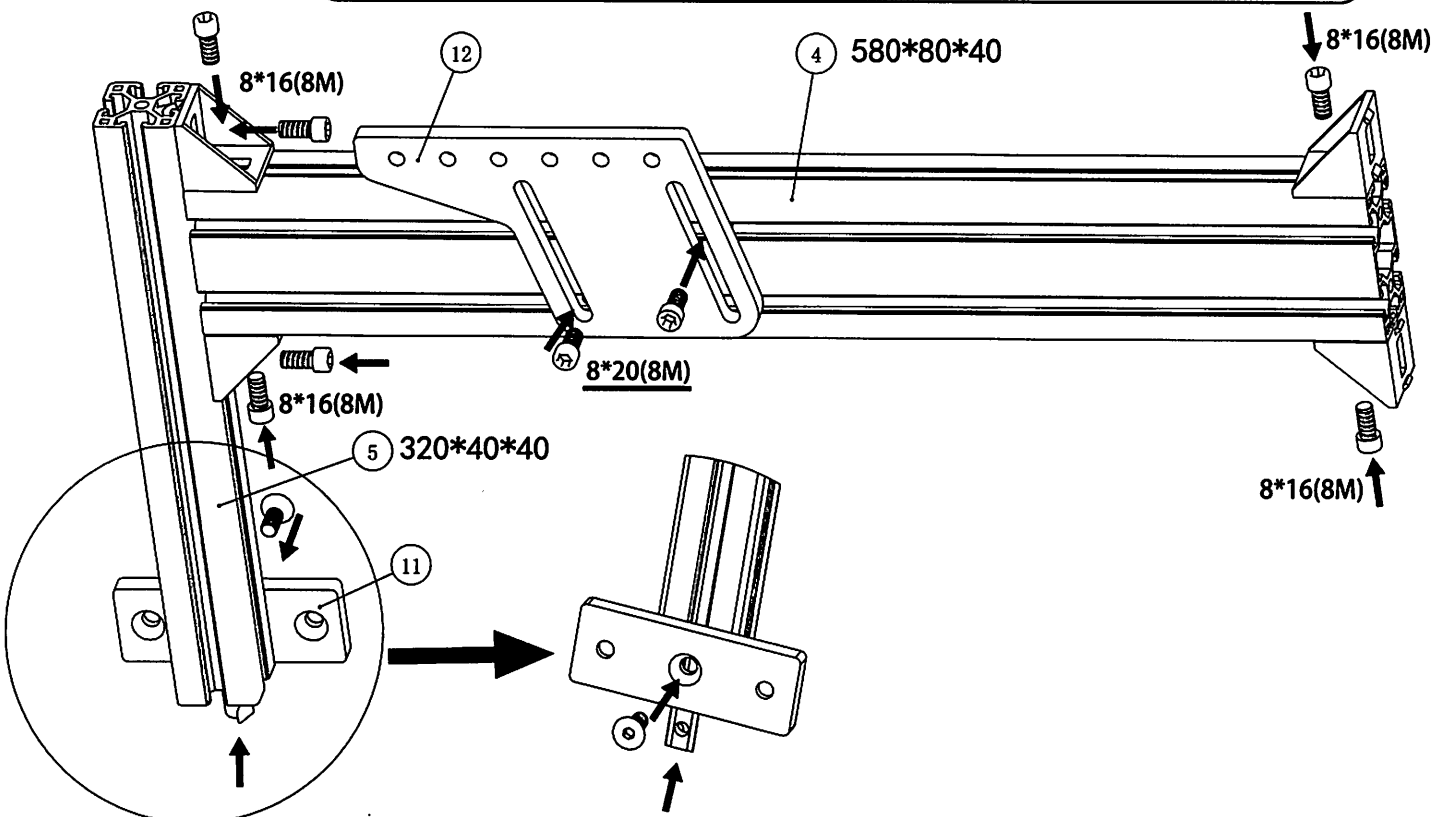

11

- 8*16(8M) x2
- x2
- x4
- 6*16(6M) x2
- 6M x2

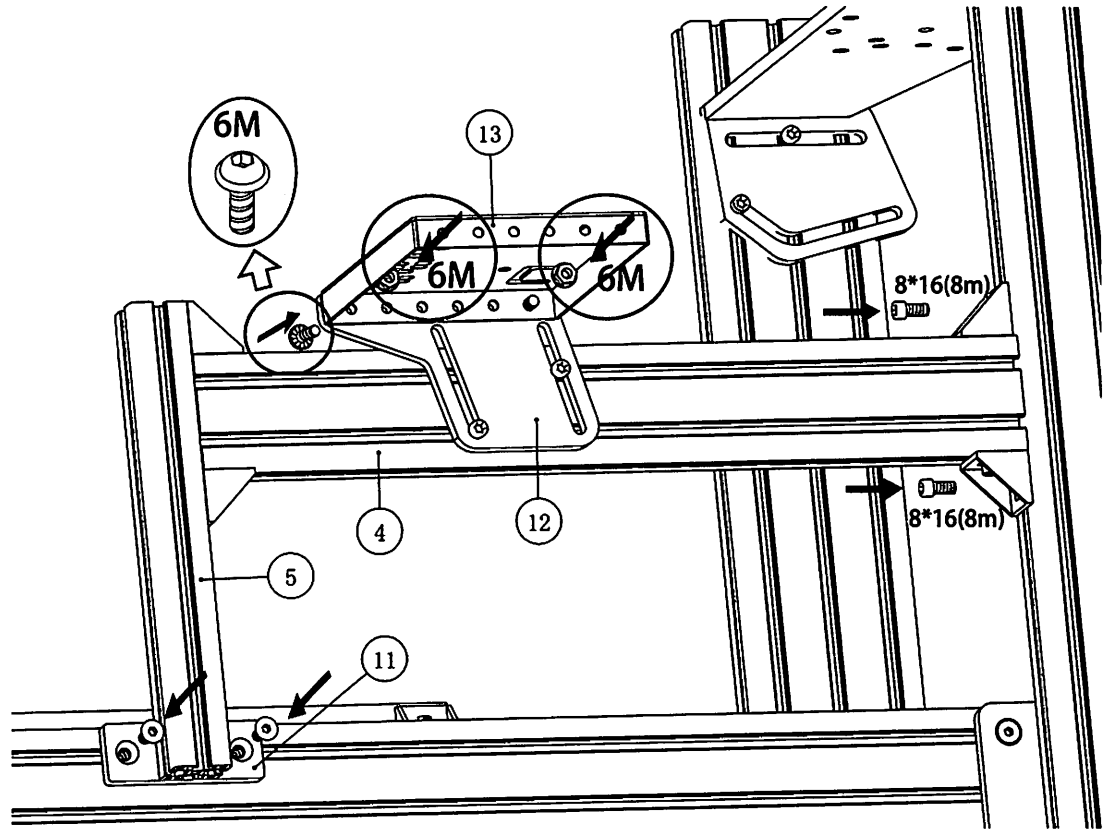

12

- x6
- x4
- x4
- x6
- x6

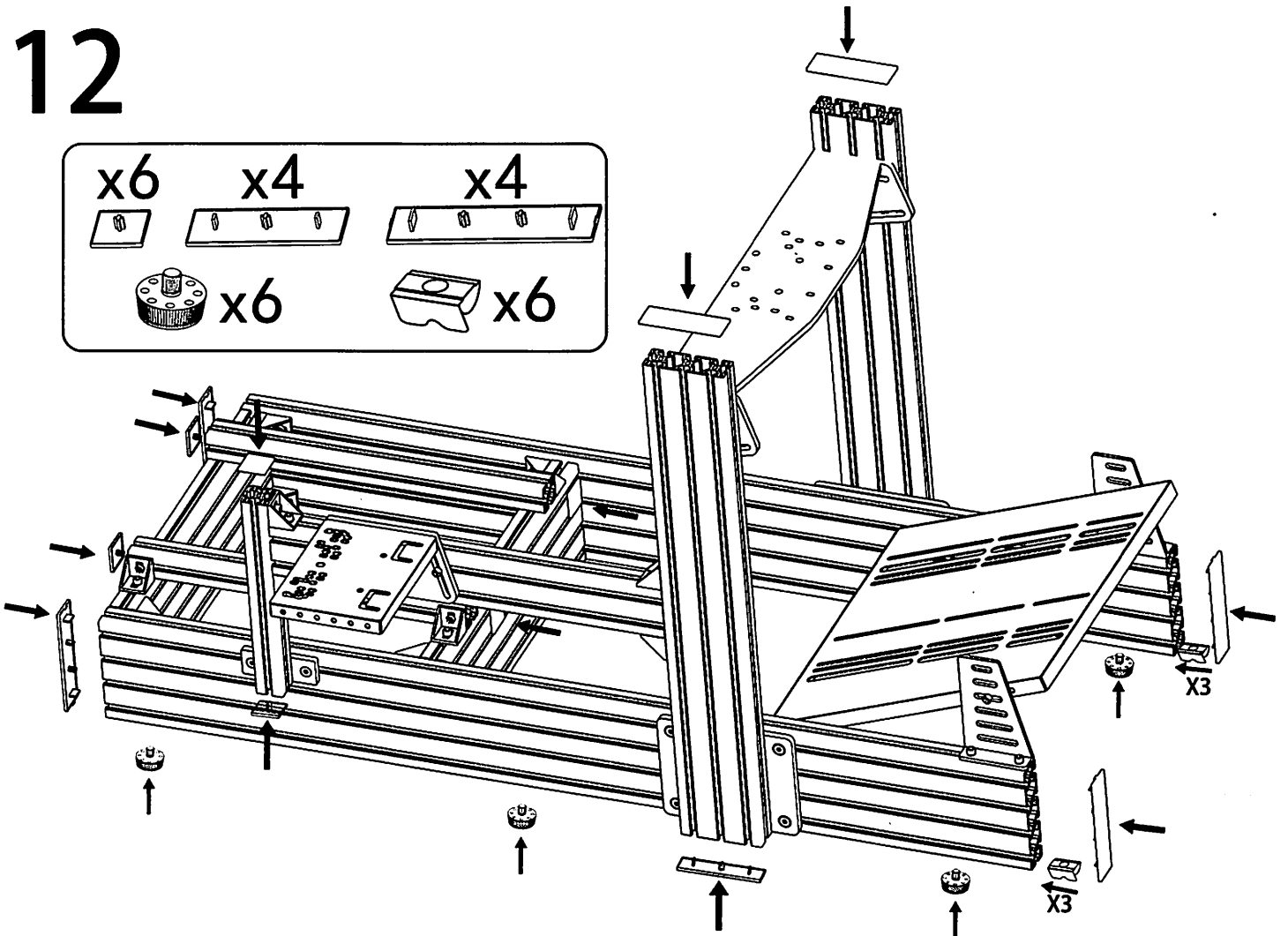



GT Omega